



ΠΑΝΕΠΙΣΤΗΜΙΟ ΚΥΠΡΟΥ

Σχολή Θετικών και Εφαρμοσμένων Επιστημών
Τμήμα Μαθηματικών και Στατιστικής

**Topics in Geometric Function Theory and
Harmonic Analysis**

Martin Lamprecht

Διατριβή η οποία υποβλήθηκε προς απόκτηση
διδαστορικού τίτλου σπουδών στο Πανεπιστήμιο Κύπρου

Απρίλιος 2010

Martin Lamprecht

© Martin Lamprecht

Εξεταστική Επιτροπή

Prof. Dr. Stamatis Koumandos, University of Cyprus
Prof. Dr. Stephan Ruscheweyh, Universität Würzburg
Prof. Dr. Nikos Stylianopoulos, University of Cyprus
Prof. Dr. Ted J. Suffridge, University of Kentucky
Prof. Dr. Alekos Vidras, University of Cyprus

Ερευνητικός Σύμβουλος: Prof. Dr. Stamatis Koumandos

Περίληψη

Στην παρούσα διατριβή μελετώνται ορισμένα προβλήματα στη γεωμετρική θεωρία συναρτήσεων και την αρμονική ανάλυση.

Έστω $c_{2k} = c_{2k+1} = 2^{-2k} \binom{2k}{k}$, $k \in \mathbb{N}_0$. Ο Vietoris έδειξε ότι

$$\sigma_n(x) = \sum_{k=1}^n c_k \sin kx > 0 \quad \text{και} \quad \tau_n(x) = \sum_{k=0}^n c_k \cos kx > 0$$

για όλα τα $n \in \mathbb{N}$ και $x \in (0, \pi)$. Στο πρώτο κεφάλαιο παρουσιάζουμε ένα νέο είδος επέκτασης για την ανισότητα ημιτόνου του Vietoris. Η επέκταση αυτή επιτυγχάνεται με τον καθορισμό όλων των θετικών αλγεβρικών πολυωνύμων p του πιο μικρού βαθμού που ικανοποιούν τη σχέση $\sigma_n(x) \geq p(x)$ για όλα τα $n \in \mathbb{N}$ και $x \in (0, \pi)$. Αποδεικνύουμε, επίσης, μια επέκταση μιας στοιχειώδους ανισότητας στην αρμονική ανάλυση, η οποία μπορεί να αποδειχθεί χρήσιμη στον καθορισμό ενός πολυωνυμικού κάτω φράγματος για την ανισότητα συνημιτόνου του Vietoris.

Στο δεύτερο κεφάλαιο παρουσιάζουμε ορισμένα καινούργια αποτελέσματα σχετικά με την ακόλουθη εικασία των Koumantou και Ruscheweyh: Αν το $\mu(\rho)$, $\rho \in (0, 1]$, δηλώνει το μέγιστο αριθμό στο $(0, 1]$ για τον οποίο

$$\left| \arg \left[(1-z)^\rho \sum_{k=0}^n \frac{(\mu)_k}{k!} z^k \right] \right| \leq \frac{\rho\pi}{2} \quad \text{για όλα τα} \quad n \in \mathbb{N}, 0 < \mu \leq \mu(\rho),$$

τότε το $\mu(\rho)$ είναι ίσο με τη μοναδική λύση $\mu^*(\rho)$ στο $(0, 1]$ της εξίσωσης

$$\int_0^{(\rho+1)\pi} \frac{\sin(t - \rho\pi)}{t^{1-\mu}} dt = 0.$$

Μεταξύ άλλων, δείχνουμε πως αυτή η εικασία είναι ισοδύναμη με τη θετικότητα μιας ορισμένης οικογένειας τριγωνομετρικών αθροισμάτων και χρησιμοποιούμε αυτό το αποτέλεσμα για να επιβεβαιώσουμε την εικασία των Koumantou και Ruscheweyh για όλα τα ρ σε μια ανοικτή περιοχή του $\frac{1}{5}$.

Στο τρίτο κεφάλαιο καθορίζουμε πλήρως το σύνολο των $(\alpha, \beta) \in \mathbb{R}^2$, για τα οποία η συνάρτηση

$$f_{\alpha, \beta}(x) = \frac{e^{\alpha x} - e^{\beta x}}{e^x - 1}$$

είναι κοίλη ή κυρτή σε όλο το $(0, \infty)$. Το αποτέλεσμα αυτό μπορεί να χρησιμοποιηθεί για να επιβεβαιώσει την πλήρη μονοτονία ορισμένων συναρτήσεων, που περιλαμβάνουν τη συνάρτηση γάμμα ή ψι και οι οποίες παίζουν σημαντικό ρόλο στη μέθοδο του Koumantou για την απόδειξη της θετικότητας των τριγωνομετρικών αθροισμάτων με ακολουθίες συντελεστών του τύπου $\left\{ \frac{(\mu)_k}{k!} \right\}_{k \in \mathbb{N}_0}$.

Από τα θεωρήματα των Grace και Gauß-Lucas συνεπάγεται ότι αν τα

$$P(z) = \sum_{k=0}^n \binom{n}{k} a_k z^k \quad \text{και} \quad Q(z) = \sum_{k=0}^{n-1} \binom{n-1}{k} b_k z^k$$

είναι πολυώνυμα βαθμού n και $n-1$ αντίστοιχα, που έχουν όλες τις ρίζες στον κλειστό μοναδιαίο δίσκο, τότε το πολυώνυμο

$$\sum_{k=0}^{n-1} \binom{n-1}{k} a_{k+1} b_k z^k$$

επίσης έχει όλες τις ρίζες στον κλειστό μοναδιαίο δίσκο. Στο τέταρτο κεφάλαιο αποδεικνύουμε ότι αυτό το αποτέλεσμα έχει μια επέκταση στις τάξεις πολυωνύμων του Suffridge με περιορισμένες ρίζες στον μοναδιαίο κύκλο. Δείχνουμε, επίσης, ότι δεν φαίνεται να είναι δυνατή τυχόν επέκταση του θεωρήματος του Laguerre στις τάξεις πολυωνύμων του Suffridge και δίνουμε μια απάντηση σε ένα παλαιό ερώτημα που τέθηκε από τον Suffridge σχετικά με το θεώρημα των Gauß-Lucas.

Στο τελευταίο κεφάλαιο αποδεικνύουμε ότι αν η f είναι αστεροειδής συνάρτηση, το z βρίσκεται στο μοναδιαίο δίσκο, και $\gamma(t) = f^{-1}(tf(z))$, $t \in [0, 1]$, τότε

$$\left| \int_0^1 \arg \frac{z}{\gamma'(t)} dt \right| < \frac{\pi}{2}.$$

Αυτή η καινούργια ιδιότητα των αστεροειδών συναρτήσεων χρησιμοποιείται για ναδειχθεί ότι αν η f είναι αστεροειδής και $\alpha \in [0, 1]$, τότε η

$$I_\alpha[f](z) = \int_0^z (f'(\zeta))^\alpha d\zeta$$

είναι επίσης αστεροειδής. Επιπρόσθετα, αποδεικνύουμε ότι η αντίστοιχη πρόταση για σπειροειδείς συναρτήσεις δεν ισχύει και καθορίζουμε το ακριβές εύρος των $\alpha \in \mathbb{R}$, για τα οποία η $I_\alpha[f]$ είναι μονότιμη για όλες τις αστεροειδείς συναρτήσεις f .

Abstract

In this thesis several problems in geometric function theory and harmonic analysis are considered.

Let $c_{2k} = c_{2k+1} = 2^{-2k} \binom{2k}{k}$, $k \in \mathbb{N}_0$. It was shown by Vietoris that

$$\sigma_n(x) = \sum_{k=1}^n c_k \sin kx > 0 \quad \text{and} \quad \tau_n(x) = \sum_{k=0}^n c_k \cos kx > 0$$

for all $n \in \mathbb{N}$ and $x \in (0, \pi)$. In the first chapter we present a new kind of refinement for Vietoris' sine inequality by determining all positive algebraic polynomials p of lowest degree that satisfy $\sigma_n(x) \geq p(x)$ for all $n \in \mathbb{N}$ and $x \in (0, \pi)$. We also prove an extension of an elementary inequality in harmonic analysis that may be of use in determining a polynomial lower bound for Vietoris' cosine inequality.

In the second chapter we present several new results concerning the following conjecture of Koumandos and Ruscheweyh: If $\mu(\rho)$, $\rho \in (0, 1]$, denotes the maximal number in $(0, 1]$ for which

$$\left| \arg \left[(1-z)^\rho \sum_{k=0}^n \frac{(\mu)_k}{k!} z^k \right] \right| \leq \frac{\rho\pi}{2} \quad \text{for all } n \in \mathbb{N}, 0 < \mu \leq \mu(\rho),$$

then $\mu(\rho)$ is equal to the unique solution $\mu^*(\rho)$ in $(0, 1]$ of the equation

$$\int_0^{(\rho+1)\pi} \frac{\sin(t - \rho\pi)}{t^{1-\mu}} dt = 0.$$

Among other things, we show that this conjecture is equivalent to the positivity of a certain family of trigonometric sums and use this result in order to verify Koumandos and Ruscheweyh's conjecture for all ρ in an open neighborhood of $\frac{1}{5}$.

In the third chapter we completely determine the range of $(\alpha, \beta) \in \mathbb{R}^2$ for which the function

$$f_{\alpha, \beta}(x) = \frac{e^{\alpha x} - e^{\beta x}}{e^x - 1}$$

is concave or convex in the whole of $(0, \infty)$. This result can be used to verify the complete monotonicity of certain functions that involve the gamma or psi function and that play an important role in Koumandos' method for proving the positivity of trigonometric sums with coefficient sequences of the form $\left\{ \frac{(\mu)_k}{k!} \right\}_{k \in \mathbb{N}_0}$.

It follows from the theorems of Grace and Gauß-Lucas that if $P(z) = \sum_{k=0}^n \binom{n}{k} a_k z^k$ and $Q(z) = \sum_{k=0}^{n-1} \binom{n-1}{k} b_k z^k$ are polynomials of degree n and $n-1$, respectively, that have all their zeros in the closed unit disk, then the polynomial

$$\sum_{k=0}^{n-1} \binom{n-1}{k} a_{k+1} b_k z^k$$

also has all its zeros in the closed unit disk. In the fourth chapter we prove that this result has an extension to Suffridge's classes of polynomials with restricted zeros on the unit circle. We also show that there seems to be no extension of the theorem of Laguerre to Suffridge's polynomial classes and give an answer to an old question posed by Suffridge regarding the theorem of Gauß-Lucas.

In the last chapter we prove that if f is a starlike function, z lies in the unit disk, and $\gamma(t) = f^{-1}(tf(z))$, $t \in [0, 1]$, then

$$\left| \int_0^1 \arg \frac{z}{\gamma'(t)} dt \right| < \frac{\pi}{2}.$$

This new property of starlike functions is used to show that if f is starlike and $\alpha \in [0, 1]$, then

$$I_\alpha[f](z) = \int_0^z (f'(\zeta))^\alpha d\zeta$$

is also starlike. Moreover, we prove that the corresponding statement for spirallike functions is not true and determine the exact range of $\alpha \in \mathbb{R}$ for which $I_\alpha[f]$ is univalent for all starlike functions f .

Contents

List of Figures	vi
Preface / Acknowledgements	vii
Chapter 1. On Vietoris' Inequalities	1
1.1. A Refinement of Vietoris' Inequality for Sine Polynomials	4
1.2. An Extension of an Elementary Inequality	8
Chapter 2. On a Conjecture for Trigonometric Sums and Starlike Functions	13
2.1. Some New Properties of the Function $\mu^*(\rho)$	14
2.2. On the Conjecture of Koumandos and Ruscheweyh	18
Chapter 3. Some Completely Monotonic Functions	28
3.1. The Set \mathfrak{M}	31
3.2. The Set \mathfrak{C}	33
3.3. On the Third Derivative of $f_\alpha(x)$	38
Chapter 4. On Suffridge's Polynomial Classes	41
4.1. Some Results Concerning Blaschke Products and Self-Inversive Convolution Operators	45
4.2. An Extension of Suffridge's Inclusion Theorem	50
4.3. Laguerre's Theorem for the Classes $\mathcal{P}_n(\lambda)$	55
4.4. On a Question of Suffridge	60
Chapter 5. On Some Integral Operators in Geometric Function Theory	63
5.1. A New Property of Starlike Functions	65
5.2. The Set of Starlike Functions Is Starlike	70
5.3. Functions with Complex Corners	72
Bibliography	78

List of Figures

2.1 The graph of the function $\mu^*(\rho)$	15
3.1 The sets Y and Z	31
3.2 The sets A , B and C	33
3.3 The set C	34
3.4 The sets P and N	37

Preface / Acknowledgements

This thesis contains the results of the research I have conducted over the past three years. Each of its five chapters is based on one of the five research papers [Lam07, KL09a, KL09b, Lam10, AKL] that I have authored or co-authored so far. As a result of this, the chapters are more or less independent of one another. However, they are not as unrelated as they might seem at first sight.

Koumandos' extension of Vietoris' cosine inequality in [Kou07] is the thread connecting the first three chapters. On one hand, it is equivalent to the case $\rho = \frac{1}{2}$ of Koumandos and Ruscheweyh's conjecture as presented in Chapter 2. On the other hand, the fact that it is not possible to obtain a similar extension of Vietoris' sine inequality leads to the question whether there is any other way of extending or refining this inequality. This question is addressed in Chapter 1. Moreover, Koumandos' method for proving the positivity of trigonometric sums with coefficient sequences of the form $\{\frac{(\mu)_k}{k!}\}$ requires estimates for functions of the form

$$x - \frac{\Gamma(x + \mu)}{\Gamma(x + 1)}x^{2-\mu}, \quad x > 0, \mu \in (0, 1).$$

This problem is the starting point for the considerations that are presented in Chapter 3.

Because of Theorem 4.5, for large n the polynomial $Q_n(\frac{2\pi}{n+\mu})$ is very close to the polynomial $s_n^\mu(z)$. Therefore it seems reasonable to assume that Suffridge's theory might shed some new light on some of the problems that are discussed in Chapter 2 or vice versa. Unfortunately, until now no way has been found to exploit this relation any further. Nevertheless, this connection between Suffridge's polynomial classes and the conjecture of Koumandos and Ruscheweyh seems worthy of further investigation.

Finally, Theorem 4.5 also shows that every problem concerning starlike functions can be seen as a problem concerning Suffridge's polynomial classes $\mathcal{P}_n(\lambda)$. It was hoped that this connection might be of some use for the question concerning the starlikeness of the set of starlike functions that is addressed in Chapter 5. However, as it can be seen from the proof of Theorem 5.14, other methods proved more useful for the solution of this problem.

During my studies I received the help of many people. First and foremost I would like to thank my supervisor, Professor Koumandos, for his continuous help, support and encouragement over the past three and a half years. I am also very grateful that he has offered me the opportunity to work in the research project "Inequalities for special functions and applications to geometric function theory and related fields", which is funded by the Leventis Foundation. Needless to say, my thanks go to the Leventis Foundation as well. I am deeply indebted to Professor Ruscheweyh for the help and support he has offered me during all the years of my studies, both at the University of Würzburg and the University of Cyprus. Without his encouragement I would most probably not have chosen to pursue doctoral studies and come to the University of Cyprus. Professor Suffridge's input on my research concerning 'his' polynomial classes

has been of great value for me ever since I began to work in this area. I am very happy and grateful that he has agreed to come all the way from Kentucky to be a member on my evaluation committee. I would also like to thank the other two members of this committee, Professor Stylianopoulos and Professor Vidras, for acting as referees for my thesis. Professor Vidras has also given me the opportunity to present a part of my research in a small workshop he organized at the University of Cyprus in November 2009. Last, but not least, I would like to thank Erini Karpasiti for her patience in answering all my questions regarding the rules and regulations at the University of Cyprus.

Martin Lamprecht

On Vietoris' Inequalities

The inequalities

$$\sum_{k=1}^n \frac{\sin kx}{k} > 0 \quad \text{and} \quad 1 + \sum_{k=1}^n \frac{\cos kx}{k} > 0, \quad n \in \mathbb{N}, x \in (0, \pi), \quad (1.1)$$

are classical positivity results in the theory of trigonometric polynomials. The sine inequality was conjectured by Fejér in 1910 and proven shortly afterwards by Jackson [Jac11] and Grönwall [Grö12]; the cosine one was shown by Young [You13] in 1913. The fact that

$$\lim_{x \rightarrow \pi} \sum_{k=1}^n \frac{\sin kx}{k \sin x} = \sum_{k=1}^n (-1)^{k-1}$$

vanishes when n is even, explains why for a long time the Fejér-Jackson-Grönwall inequality was thought to be sharp. However, in 1958 Vietoris [Vie58, Vie59] was able to extend both inequalities in (1.1).

THEOREM 1.1. *If $\{a_k\}_{k \in \mathbb{N}_0}$ is a decreasing sequence of non-negative real numbers that satisfies*

$$2ka_{2k} \leq (2k-1)a_{2k-1} \quad (1.2)$$

for $k \geq 1$, then for $n \in \mathbb{N}$ and $x \in (0, \pi)$

$$\sum_{k=1}^n a_k \sin kx > 0 \quad \text{and} \quad \sum_{k=0}^n a_k \cos kx > 0. \quad (1.3)$$

Using summation by parts it is easy to see that one needs to prove (1.3) only for coefficient sequences $\{a_k\}_{k \in \mathbb{N}_0}$ that satisfy $a_{2(k-1)} = a_{2k-1}$ and $2ka_{2k} = (2k-1)a_{2k-1}$ for $k \geq 1$ (i.e. coefficient sequences for which equality holds in (1.2)). With the additional condition $a_0 = 1$, one obtains the coefficients $a_k = c_k$, where

$$c_{2k} = c_{2k+1} := 2^{-2k} \binom{2k}{k} = \frac{\left(\frac{1}{2}\right)_k}{k!}. \quad (1.4)$$

Here

$$(a)_k := a(a+1) \cdots (a+k-1) = \frac{\Gamma(k+a)}{\Gamma(a)} \quad (1.5)$$

is the so-called *Pochhammer symbol* and $\Gamma(x)$ is Euler's *gamma function* defined by

$$\Gamma(x) = \int_0^\infty t^{x-1} e^{-t} dt \quad \text{for} \quad \operatorname{Re} x > 0.$$

Theorem 1.1 is thus equivalent to the following statement.

THEOREM 1.2. *If the numbers c_k are given by (1.4), then for $n \in \mathbb{N}$ and $x \in (0, \pi)$*

$$\sigma_n(x) := \sum_{k=1}^n c_k \sin kx > 0 \quad \text{and} \quad \tau_n(x) := \sum_{k=0}^n c_k \cos kx > 0.$$

Surprisingly, Vietoris' theorem remained nearly unknown for more than 15 years, until Vietoris' paper was discovered by Askey in 1974. He and Steinig [AS74] provided a new and simplified proof of Vietoris' theorem and gave several interesting new applications of the inequalities (1.3) (see [Ask98] for the story behind this). Among other things, Askey and Steinig showed that Vietoris' inequalities can be used to estimate the zeros of trigonometric polynomials and to obtain new positive sums of ultraspherical polynomials.

As a result of Askey and Steinig's paper Vietoris' theorem became widely known and is now one of the most quoted results in (and from) the theory of positive trigonometric sums. For instance, Ruscheweyh [Rus87] used Theorem 1.1 to derive coefficient conditions for starlike functions. Ruscheweyh and Salinas [RS04] showed that Vietoris' inequalities appear naturally in the context of so-called 'stable' functions. Some other areas in which Vietoris' theorem has found applications are quadrature methods and hypergeometric summation and transformation [Ask98].

Vietoris' inequalities have been generalized in several ways. An extension which is perhaps the most far reaching has been obtained Belov [Bel95]. In an extremely involved proof he showed that for any decreasing sequence $\{a_n\}_{n \in \mathbb{N}_0}$ of non-negative real numbers the inequalities (1.3) hold for all $n \in \mathbb{N}_0$ and $x \in (0, \pi)$ if $a_1 > 0$ and

$$\sum_{k=1}^{2n} (-1)^{k-1} k a_k = \sum_{k=1}^n ((2k-1)a_{2k-1} - 2ka_{2k}) \geq 0 \quad \text{for all } n \geq 1. \quad (1.6)$$

Since

$$\lim_{x \rightarrow \pi} \sum_{k=1}^{2n} a_k \frac{\sin kx}{\sin x} = \sum_{k=1}^{2n} (-1)^{k-1} k a_k,$$

Belov's condition (1.6) is sufficient and necessary for the sine inequality in (1.3). A nice example of a coefficient sequence that satisfies Belov's condition (1.6) but not Vietoris' (1.2), is the sequence $\{a_k\}_{k \in \mathbb{N}_0}$, defined by $a_0 = a_1 = 1$ and $a_k = (k + \alpha)^{-1}$ for $k \geq 2$ with $\alpha > 0$. It is easy to verify that $(k+1)a_{k+1} > ka_k$ for $k \geq 2$ and therefore the sequence $\{a_k\}_{k \in \mathbb{N}_0}$ does not satisfy Vietoris' condition. However, since

$$\sum_{k=1}^{2n} (-1)^{k-1} k a_k = 1 - 2na_{2n} + \sum_{k=1}^{n-1} ((2k+1)a_{2k+1} - 2ka_{2k}) > 0$$

for all $n \geq 1$, it satisfies Belov's one.

A very interesting way of generalizing Vietoris' inequalities has been proposed by Ruscheweyh and Salinas. In [RS04] they showed that Vietoris' theorem is (essentially) equivalent to the fact that for $\lambda = \frac{1}{2}$

$$\left| \arg \frac{s_n^\lambda(z)}{v_\lambda(z)} \right| < \lambda \frac{\pi}{2}, \quad z \in \mathbb{D}, n \in \mathbb{N}_0, \quad (1.7)$$

where

$$v_\lambda(z) := \sum_{k=0}^{\infty} a_{k,\lambda} z^k := \left(\frac{1+z}{1-z} \right)^\lambda \quad \text{and} \quad s_n^\lambda(z) := \sum_{k=0}^n a_{k,\lambda} z^k.$$

They conjecture that (1.7) remains true for $\lambda \in (0, \frac{1}{2}]$. This would imply that for those λ one has

$$0 < \arg s_n^\lambda(e^{i\theta}) < \lambda\pi \quad \text{for } \theta \in (0, \pi), n \in \mathbb{N}_0.$$

The fact that strongly distinguishes Ruscheweyh and Salinas' conjecture from other known extensions of Vietoris' inequality is that for $\lambda \in (0, \frac{1}{2})$ the coefficient sequences

$\{a_{k,\lambda}\}_{k \in \mathbb{N}_0}$ need not be monotonic. Using computer algebra, Ruscheweyh and Salinas verified their conjecture for $\lambda = \frac{1}{4}$ and $n = 1, 2, \dots, 5000$.

Weakened coefficient conditions under which the cosine inequality $\tau_n(x) > 0$ remains true were considered in [BH84, BY01, BDW07]. Best possible results in this direction were obtained in [Kou07], where – among other things – it is shown that for the coefficient sequence

$$a_{2k} = a_{2k+1} = \frac{(1-\alpha)_k}{k!}, \quad \alpha \in (0, 1), \quad k \in \mathbb{N}_0 \quad (1.8)$$

the inequality

$$\sum_{k=0}^n a_k \cos kx > 0$$

holds for all $n \in \mathbb{N}$ and $x \in (0, \pi)$ if, and only if, $\alpha \geq \alpha_0$. Here α_0 is defined as the unique solution in $(0, 1)$ of the equation

$$\int_0^{\frac{3\pi}{2}} \frac{\cos t}{t^\alpha} dt = 0. \quad (1.9)$$

Approximately, $\alpha_0 = 0.3084437\dots$. Note that the coefficient sequence $\{a_k\}_{k \in \mathbb{N}_0}$ defined in (1.8) does not satisfy Belov's coefficient condition if $\alpha < \frac{1}{2}$.

For the sine sums $\sigma_n(x)$ no such extension is possible: while it is shown in [BDW07, Kou07] that for the coefficient sequence (1.8) the inequality

$$\sum_{k=1}^{2n+1} a_k \sin kx > 0$$

holds for all $n \in \mathbb{N}$ and $x \in (0, \pi)$ if, and only if, $\alpha \geq \alpha_0$, for an even number of summands one has

$$\lim_{x \rightarrow \pi} \sum_{k=1}^{2n} a_k \frac{\sin kx}{\sin x} = \sum_{k=1}^n ((2k-1)a_{2k-1} - 2ka_{2k}). \quad (1.10)$$

Since the coefficient sequence (1.8) satisfies

$$2ka_{2k} = (2k-2\alpha)a_{2k-1} \quad \text{for } k \geq 1, \quad (1.11)$$

(1.10) and Theorem 1.1 thus show that for the sequence (1.8) the inequality

$$\sum_{k=1}^n a_k \sin kx > 0$$

holds for all $n \in \mathbb{N}$ and $x \in (0, \pi)$ if, and only if, $\alpha \geq \frac{1}{2}$.

It is therefore of interest to find other ways of extending or refining Vietoris' sine inequality. A new kind of refinement of the sine inequality will be the main result of this chapter: we will determine the positive algebraic polynomial $p(x)$ of lowest degree such that $\sigma_n(x) > p(x)$ for all $n \in \mathbb{N}$ and $x \in (0, \pi)$. The same question for Vietoris' cosine inequality is still not completely settled. In this chapter we will also show how results from Vietoris' paper [Vie58] lead to an extension of an elementary trigonometric inequality that may be of use in the search of a polynomial lower bound for the cosine polynomials $\tau_n(x)$.

1.1. A Refinement of Vietoris' Inequality for Sine Polynomials

In this section we shall provide a polynomial lower bound for the trigonometric polynomials $\sigma_n(x)$.

In [AKL] the authors asked for positive algebraic polynomials p of smallest degree such that

$$\sigma_n(x) \geq p(x) > 0 \quad \text{for all } n \in \mathbb{N}, x \in (0, \pi). \quad (1.12)$$

It is shown there that such a polynomial has to be of degree at least 4 and that, if p is a polynomial of degree 4, (1.12) holds if, and only if,

$$p(x) = ax(\pi - x)^3 \quad \text{and} \quad a \in \left(0, \frac{1}{\pi^3}\right]. \quad (1.13)$$

Here we will prove the 'if'-direction of this equivalence. Since

$$0 < ax(\pi - x)^3 \leq x \left(1 - \frac{x}{\pi}\right)^3$$

for $a \in \left(0, \frac{1}{\pi^3}\right]$ and $x \in (0, \pi)$, this reduces to the following.

THEOREM 1.3. *We have*

$$\sigma_n(x) > x \left(1 - \frac{x}{\pi}\right)^3 \quad \text{for all } n \in \mathbb{N}, x \in (0, \pi). \quad (1.14)$$

For the proof of this theorem we need some auxiliary results.

LEMMA 1.4. *For all integers $n \geq 8$ we have*

$$0 < \sqrt{\sin \frac{\pi}{n}} - 2c_{n+1} - \frac{2(n-1)\pi}{n^4}. \quad (1.15)$$

PROOF. It is well known that for $x > 0$

$$\sin x > x - \frac{x^3}{6}.$$

Setting $x = \frac{\pi}{n}$ in this inequality, we find that the right-hand side of (1.15) is larger than

$$\Delta_n := \sqrt{\frac{\pi}{n} \left(1 - \frac{\pi^2}{6n^2}\right)} - 2c_{n+1} - \frac{2(n-1)\pi}{n^4}.$$

Making use of the fact that

$$c_{2k} = c_{2k+1} < \frac{1}{\sqrt{k\pi}}$$

for $k \in \mathbb{N}$ [AS74, Lem. 1] and setting

$$R_x = R(x) = \frac{\pi}{x} \sqrt{x^2 - \frac{\pi^2}{6}} - \frac{2\pi(x-1)}{x^3} \sqrt{\frac{\pi}{x}},$$

we obtain

$$\sqrt{2k\pi} \Delta_{2k} > R_{2k} - 2\sqrt{2}$$

and

$$\sqrt{(2k-1)\pi} \Delta_{2k-1} > R_{2k-1} - 2\sqrt{2 - \frac{1}{k}} > R_{2k-1} - 2\sqrt{2}.$$

Thus, it remains to show that

$$R(x) \geq 2\sqrt{2} \quad \text{for } x \geq 8.$$

We have

$$\frac{x^{9/2}}{\pi^{3/2}} \sqrt{36x^2 - 6\pi^2} R'(x) = \pi^{3/2} x^{5/2} + (5x - 7) \sqrt{36x^2 - 6\pi^2}.$$

Hence, if $x \geq 8$, then

$$R'(x) > 0 \quad \text{and} \quad R(x) \geq R(8) = 3.047\dots > 2\sqrt{2}.$$

□

A proof for the next lemma can be found in [Vie58, p. 128].

LEMMA 1.5. *Let $n \geq m \geq 2$ and $x \in (0, \pi)$. Then*

$$\sigma_n(x) \geq \sigma_{m-1}(x) + c_m \frac{\cos((m - \frac{1}{2})x) - 1}{2 \sin \frac{x}{2}}.$$

As our final auxiliary result we prove the cases $n = 1, 2, 3$ of Theorem 1.3.

LEMMA 1.6. *For all $x \in (0, \pi)$ we have*

$$x \left(1 - \frac{x}{\pi}\right)^3 < \sin x, \tag{1.16}$$

$$x \left(1 - \frac{x}{\pi}\right)^3 < \sin x + \frac{1}{2} \sin 2x, \tag{1.17}$$

$$x \left(1 - \frac{x}{\pi}\right)^3 < \sin x + \frac{1}{2} \sin 2x + \frac{1}{2} \sin 3x. \tag{1.18}$$

PROOF. Since

$$1 - \frac{x}{\pi} < \frac{\sin x}{x} \tag{1.19}$$

[AS65, (4.3.82)] and since $0 < 1 - \frac{x}{\pi} < 1$ for $x \in (0, \pi)$, it is clear that (1.16) is true.

Applying (1.19) and

$$\sin x + \frac{1}{2} \sin 2x = (1 + \cos x) \sin x$$

we conclude that (1.17) is proved if

$$\frac{x}{\pi} \left(\frac{x}{\pi} - 2\right) < \cos x. \tag{1.20}$$

This obviously holds for $x \in (0, \frac{\pi}{2}]$. If

$$f(x) = \cos x - \frac{x}{\pi} \left(\frac{x}{\pi} - 2\right),$$

then

$$f'''(x) = \sin x, \quad f' \left(\frac{\pi}{2}\right) = \frac{1}{\pi} - 1 < 0, \quad f'(\pi) = 0.$$

Hence, f' is negative on $(\frac{\pi}{2}, \pi)$. Since $f(\pi) = 0$, it follows that (1.20) also holds for $x \in (\frac{\pi}{2}, \pi)$.

Using (1.19) and

$$\sin x + \frac{1}{2} \sin 2x + \frac{1}{2} \sin 3x = \left(\frac{1}{2} + \cos x + 2 \cos^2 x\right) \sin x$$

we conclude that in order to prove (1.18) we have to show that

$$u(x) := \left(1 - \frac{\arccos x}{\pi}\right)^2 < \frac{1}{2} + x + 2x^2 =: v(x) \tag{1.21}$$

for $x \in (-1, 1)$. We calculate

$$\pi^2 (1 - x^2)^{3/2} u''(x) = 2\sqrt{1 - x^2} + 2x(\pi - \arccos x),$$

and therefore see that u is convex in $(-1, 1)$. Since it is easy to check that v is larger than the piecewise affine function that connects the three points $(j, u(j))$, $j = -1, 0, 1$, the proof of the lemma is complete. \square

We can now proceed to the proof of Theorem 1.3.

PROOF OF THEOREM 1.3. Because of Lemma 1.6 it just remains to prove Theorem 1.3 for $n \geq 4$. We will split the proof into four parts.

(1) The case $x \in (0, \frac{\pi}{3}]$. An application of Lemma 1.5 with $m = 4$ leads to

$$\sigma_n(x) \geq \sin x + \frac{1}{2} \sin 2x + \frac{1}{2} \sin 3x + \frac{3}{16} \frac{\cos \frac{7x}{2} - 1}{\sin \frac{x}{2}} =: T_1(x) \quad (1.22)$$

for $n \geq 4$ and $x \in (0, \pi)$. We have

$$T_1(x) = \sin x + \frac{P_1(\cos \frac{x}{2})}{16 \sin \frac{x}{2}},$$

where

$$P_1(u) = -64u^7 + 112u^5 - 40u^3 - 5u - 3.$$

Sturm's theorem [RS02, p. 336] gives that P_1 has precisely one zero on $[\cos \frac{\pi}{12}, 2]$. Since $P_1(\cos \frac{\pi}{12}) > 0$ and $P_1(1) = 0$, we conclude that P_1 is positive on $[\cos \frac{\pi}{12}, 1)$ and hence that $P_1(\cos \frac{x}{2})$ is positive on $(0, \frac{\pi}{6}]$. It thus follows from (1.22) and (1.16) that for $n \geq 4$ and $x \in (0, \frac{\pi}{6}]$

$$\sigma_n(x) > T_1(x) > \sin x > x \left(1 - \frac{x}{\pi}\right)^3.$$

Differentiation gives

$$T_1'(x) = \frac{P_2(\cos \frac{x}{2})}{\sin^2 \frac{x}{2}},$$

where

$$P_2(u) = -12u^8 + 28u^6 - 22u^4 + \frac{27}{4}u^2 + \frac{3}{32}u - \frac{27}{32}.$$

Sturm's theorem reveals that P_2 has precisely one zero on $[\cos \frac{\pi}{6}, \cos \frac{\pi}{12}]$. Since $P_2(\cos \frac{\pi}{6}) < 0$, we obtain

$$\sigma_n(x) > T_1(x) > \min \left(T_1 \left(\frac{\pi}{6} \right), T_1 \left(\frac{\pi}{3} \right) \right) > x \left(1 - \frac{x}{\pi}\right)^3$$

for $n \geq 4$ and $x \in (\frac{\pi}{6}, \frac{\pi}{3}]$.

(2) The case $x \in (\frac{\pi}{3}, \frac{6\pi}{7}]$. An application of Lemma 1.5 with $m = 3$ leads to

$$\sigma_n(x) \geq \sin x + \frac{1}{2} \sin 2x + \frac{1}{4} \frac{\cos \frac{5x}{2} - 1}{\sin \frac{x}{2}} =: T_2(x) \quad (1.23)$$

for $n \geq 3$ and $x \in (0, \pi)$. We have

$$-16 \frac{(\cos \frac{x}{2} + 1)^2}{\sin \frac{x}{2}} T_2''(x) = P_3 \left(\cos \frac{x}{2} \right),$$

with

$$P_3(x) := 16x^3 + 32x^2 + 16x + 1.$$

$P_3(x)$ is positive on $[\cos \frac{6\pi}{14}, \cos \frac{\pi}{6})$ and thus $T_2(x)$ is concave on $(\frac{\pi}{3}, \frac{6\pi}{7}]$. It is easy to check that in this interval the affine function connecting the points $(\frac{\pi}{3}, T_2(\frac{\pi}{3}))$ and $(\frac{6\pi}{7}, T_2(\frac{6\pi}{7}))$ is larger than $x(1 - \frac{x}{\pi})^3$. Hence, we have

$$\sigma_n(x) > T_2(x) > x \left(1 - \frac{x}{\pi}\right)^3$$

for $n \geq 3$ and $x \in (\frac{\pi}{3}, \frac{6\pi}{7}]$.

(3) The case $x \in (\frac{6\pi}{7}, \pi - \frac{\pi}{n}]$. We have $n \geq 8$. Since for $n \in \mathbb{N}$ and $x \in (0, \pi)$

$$2\sigma_n(x) \sin \frac{x}{2} \geq \sqrt{\sin x} - 2c_{n+1} \quad (1.24)$$

[AAR99, (7.3.19)], it suffices to show that

$$0 < \sqrt{\sin x} - 2c_{n+1} - 2x \left(1 - \frac{x}{\pi}\right)^3 =: h(x) \quad (1.25)$$

for $n \geq 8$ and $x \in (\frac{6\pi}{7}, \pi - \frac{\pi}{n}]$. We calculate

$$h''(x) = \frac{\cos^2 x - 2}{4 \sin^{3/2} x} - \frac{12}{\pi^3} (2x - \pi)(\pi - x).$$

Hence, $h''(x)$ is negative in $(\frac{\pi}{2}, \pi)$ and therefore

$$h'(x) < h' \left(\frac{6\pi}{7}\right) = -0.58\dots$$

for $x \in (\frac{6\pi}{7}, \pi)$. Consequently,

$$h(x) \geq h \left(\pi - \frac{\pi}{n}\right) = \sqrt{\sin \frac{\pi}{n}} - 2c_{n+1} - \frac{2(n-1)\pi}{n^4}$$

for $x \in (\frac{6\pi}{7}, \pi - \frac{\pi}{n}]$. Applying Lemma 1.4 we conclude that (1.25) holds for $n \geq 8$ and $x \in (\frac{6\pi}{7}, \pi - \frac{\pi}{n}]$, as required.

(4) The case $x \in (\pi - \frac{\pi}{n}, \pi)$. We follow the same method of proof as in [AS74]. Let $y = \pi - x$, so that $0 < y < \frac{\pi}{n}$. For $m \geq 2$ we have

$$\sigma_{2m}(x) = \sum_{k=1}^m \mu_k(y)$$

and

$$\sigma_{2m+1}(x) = c_{2m+1} \sin((2m+1)y) + \sum_{k=1}^m \mu_k(y),$$

where

$$\mu_k(y) = (2k-1)c_{2k-1} \left(\frac{\sin((2k-1)y)}{2k-1} - \frac{\sin(2ky)}{2k} \right).$$

Since $t \mapsto \sin(t)/t$ is strictly decreasing on $(0, \pi]$ and

$$0 < 2ky \leq 2my < \pi,$$

we obtain $\mu_k(y) > 0$ for $k = 1, 2, \dots, m$. Since moreover

$$\sin((2m+1)y) > 0 \quad \text{when} \quad y \in \left(0, \frac{\pi}{2m+1}\right),$$

we have

$$\sigma_n(x) > \mu_1(y) = \sin y - \frac{1}{2} \sin 2y = \sin x + \frac{1}{2} \sin 2x = \sigma_2(x)$$

for all integers $n \geq 4$ and $x \in (\pi - \frac{\pi}{n}, \pi)$. The case $n = 2$ of Theorem 1.3 has already been shown and the proof is therefore complete. \square

Note that Theorem 1.3 can be extended to non-negative decreasing sequences $\{a_n\}_{n \in \mathbb{N}}$ whose coefficients satisfy the relation (1.2). For, if $\{a_n\}_{n \in \mathbb{N}}$ is such a sequence, then the sequence

$$b_n := \frac{a_n}{c_n}, \quad n \in \mathbb{N},$$

is decreasing. Using summation by parts, one obtains

$$\sum_{k=1}^n a_k \sin kx = \sum_{k=1}^{n-1} \sigma_k(x)(b_k - b_{k+1}) + \sigma_n(x)b_n$$

and therefore Theorem 1.3 shows that the following statement is true.

THEOREM 1.7. *Let $\{a_k\}_{k \in \mathbb{N}_0}$ be a decreasing sequence of non-negative real numbers that satisfies the relation (1.2). Then*

$$\sum_{k=1}^n a_k \sin kx > a_1 x \left(1 - \frac{x}{\pi}\right)^3$$

for all $n \in \mathbb{N}$ and $x \in (0, \pi)$.

Having thus found a polynomial lower bound for sine sums with coefficient sequences that satisfy Vietoris' condition (1.2), it seems natural to ask whether the same is possible for sine sums with coefficient sequences that satisfy Belov's condition (1.6). But until now only little is known about this problem. Since Vietoris' coefficient condition implies Belov's coefficient condition, one thing that we know is that such a polynomial lower bound has to be of degree at least 4 and that each polynomial lower bound of degree 4 has to be of the form (1.13) (possibly with a in a smaller range than $(0, \frac{1}{\pi^3}]$).

1.2. An Extension of an Elementary Inequality

In this section we will present an extension of a classical inequality in harmonic analysis and discuss how this extension might be of help for finding a polynomial lower bound for Vietoris' cosine polynomials $\tau_n(x)$.

A sequence $\{a_n\}_{n \in \mathbb{N}_0}$ of real numbers is called a *zero sequence* if $a_n \rightarrow 0$ as $n \rightarrow \infty$. For every non-negative decreasing zero sequence $\{a_n\}_{n \in \mathbb{N}_0}$ of real numbers one has

$$\left| \sum_{k=n}^{\infty} a_k e^{ikx} \right| \leq \frac{a_n}{\sin \frac{x}{2}} \quad (1.26)$$

for all $x \in (0, 2\pi)$ and $n \in \mathbb{N}_0$. This is an elementary but nevertheless extremely important result in harmonic analysis. A proof of this classical inequality can be found in [Vie58, p. 128], where the following lemma is shown.

LEMMA 1.8. *Suppose $\{a_n\}_{n \in \mathbb{N}_0}$ is a sequence of real numbers for which there is an $n_0 \in \mathbb{N}_0$ such that the subsequence $\{a_n\}_{n \geq n_0}$ is non-negative and decreasing. For $x \in (0, 2\pi)$ set $S_{-1}(x) := 0$ and*

$$S_n(x) := \sum_{k=0}^n a_k e^{ikx}, \quad n \in \mathbb{N}_0.$$

Then for $m \geq n \geq n_0$ and $x \in (0, 2\pi)$ one has

$$|S_m(x) - S_{n-1}(x)| \leq \frac{a_n}{\sin \frac{x}{2}} \quad (1.27)$$

and

$$|S_m(x) - S_n^{(1)}(x)| \leq \frac{a_n}{2 \sin \frac{x}{2}}, \quad (1.28)$$

where

$$S_n^{(1)}(x) := S_{n-1}(x) - \frac{e^{-i\frac{\pi+x}{2}} a_n}{2 \sin \frac{x}{2}} e^{inx}.$$

It follows from (1.27) that for every non-negative decreasing zero sequence $\{a_n\}_{n \in \mathbb{N}_0}$ and every $x \in (0, 2\pi)$ the series

$$S(x) := \sum_{k=0}^{\infty} a_k e^{ikx} \quad (1.29)$$

exists and satisfies

$$|S(x) - S_{n-1}(x)| = \left| \sum_{k=n}^{\infty} a_k e^{ikx} \right| \leq \frac{a_n}{\sin \frac{x}{2}}.$$

This is inequality (1.26). Lemma 1.8 and inequality (1.26) have found numerous applications in the theory of positive trigonometric sums:

For instance, if $a_n = c_n$, with the c_n defined as in (1.4), then $\{a_n\}_{n \in \mathbb{N}_0}$ is a non-negative decreasing zero sequence for which $S_n(x) = \tau_n(x) + i\sigma_n(x)$ and

$$S(x) = (1+i) \sqrt{\frac{1}{2} \cot \frac{x}{2}}.$$

Therefore, we obtain Lemma 1.5 by taking the imaginary part of (1.28) and the relation (1.24) by taking the imaginary part of (1.26).

We will now show how one can obtain an extension of inequality (1.26) by iterating Lemma 1.8.

To this end, we need some more notation. If $\{a_n\}_{n \in \mathbb{N}_0}$ is a sequence of real numbers, then the sequence $\{\Delta^0 a_n\}_{n \in \mathbb{Z}}$ is defined by $\Delta^0 a_n := a_n$ for non-negative integers n and $\Delta^0 a_n := 0$ for negative integers n . Using this notation, we define

$$\Delta^n a_k := \Delta^{n-1} a_k - \Delta^{n-1} a_{k+1} \quad (1.30)$$

for $n \in \mathbb{N}$ and $k \in \mathbb{Z}$. By induction it is easy to see that

$$\Delta^n a_{-k} = 0 \quad \text{for } n < k \in \mathbb{N}. \quad (1.31)$$

$\{a_k\}_{k \in \mathbb{Z}}$ is called *monotonic of order* $N \in \mathbb{N}_0 \cup \{\infty\}$, if $\Delta^n a_k \geq 0$ for all $n \leq N$ and $k \in \mathbb{N}_0$. For instance, a sequence is monotonic of order 0 if, and only if, it is non-negative, and it is monotonic of order 1 if, and only if, it is non-negative and decreasing. Sequences monotonic of order ∞ are also called *completely monotonic*.

For sums $S_n(x)$ as in Lemma 1.8 and $n \in \mathbb{N}_0$ we set $S_n^{(0)}(x) := S_n(x)$ and

$$S_n^{(j)}(x) := S_{n-1}^{(j-1)}(x) - \frac{e^{-ij\frac{\pi+x}{2}} \Delta^{j-1} a_{n-j+1}}{2^j \sin^j \frac{x}{2}} e^{inx}, \quad j \geq 1. \quad (1.32)$$

We also define $S_{-1}^{(j)}(x)$ to be identically zero for all $x \in \mathbb{R}$ and $j \in \mathbb{N}$. The $S_n^{(j)}(x)$ are again partial sums of (formal) power series.

LEMMA 1.9. For $j \in \mathbb{N}_0$ and $n \geq 0$ we have

$$S_n^{(j)}(x) = \frac{e^{-ij\frac{\pi+x}{2}}}{2^j \sin^j \frac{x}{2}} \sum_{k=0}^n \Delta^j a_{k-j} e^{ikx}. \quad (1.33)$$

PROOF. The proof is by induction to n and j . The assertion is trivial if $n \in \mathbb{N}_0$ and $j = 0$. The relation (1.31) shows that for every $j \in \mathbb{N}_0$

$$S_0^{(j)}(x) = -\frac{e^{-ij\frac{\pi+x}{2}} \Delta^{j-1} a_{-j+1}}{2^j \sin^j \frac{x}{2}} = \frac{e^{-ij\frac{\pi+x}{2}}}{2^j \sin^j \frac{x}{2}} \Delta^j a_{-j}$$

and hence (1.33) holds for $n = 0$. Using the induction hypothesis and the definition of the $S_n^{(j)}$, we find that for $n, j \geq 1$

$$\begin{aligned} S_n^{(j)}(x) - S_{n-1}^{(j)}(x) &= S_{n-1}^{(j-1)}(x) - S_{n-2}^{(j-1)}(x) - c_j (\Delta^{j-1} a_{n-j+1} - \Delta^{j-1} a_{n-j} e^{-ix}) e^{inx} \\ &= c_j \left(2i \sin \frac{x}{2} \Delta^{j-1} a_{n-j} e^{-i\frac{x}{2}} - \Delta^{j-1} a_{n-j+1} + \Delta^{j-1} a_{n-j} e^{-ix} \right) e^{inx} \\ &= c_j \Delta^j a_{n-j} e^{inx}, \end{aligned}$$

where $c_j := e^{-ij\frac{\pi+x}{2}} / (2^j \sin^j \frac{x}{2})$. □

It follows from Lemmas 1.8 and 1.9 that if the sequence $\{a_n\}_{n \in \mathbb{N}_0}$ is monotonic of order $N \in \mathbb{N} \cup \{\infty\}$, then for $0 \leq j \leq N-1$, $m \geq n \geq j$, and $x \in (0, 2\pi)$ we have

$$\left| S_m^{(j)}(x) - S_{n-1}^{(j)}(x) \right| \leq \frac{\Delta^j a_{n-j}}{2^j \sin^{j+1} \frac{x}{2}}. \quad (1.34)$$

Suppose now that $\{a_n\}_{n \in \mathbb{N}_0}$ is also a zero sequence. Then it follows readily by induction that for every fixed $j \in \mathbb{N}_0$ the sequence $\Delta^{j-1} a_{n-j+1}$ tends to 0 as $n \rightarrow \infty$. Moreover, as noted before, the series $S(x)$ in (1.29) exists for all $x \in (0, 2\pi)$ and for all those x we have $S_n(x) \rightarrow S(x)$ as $n \rightarrow \infty$. (1.32) and an induction thus show that $S_n^{(j)}(x) \rightarrow S(x)$ as $n \rightarrow \infty$ for all $j \in \mathbb{N}_0$. Hence, (1.34) implies that for $0 \leq j \leq N-1$, $n \geq j$ and $x \in (0, 2\pi)$

$$\left| S(x) - S_{n-1}^{(j)}(x) \right| \leq \frac{\Delta^j a_{n-j}}{2^j \sin^{j+1} \frac{x}{2}}. \quad (1.35)$$

We obtain the following extension of inequality (1.26).

LEMMA 1.10. *Let $\{a_n\}_{n \in \mathbb{N}_0}$ be a real zero sequence that is monotonic of order $N \in \mathbb{N}$. Then*

$$\left| \sum_{k=n}^{\infty} a_k e^{ikx} \right| \leq \frac{\Delta^{N-1} a_n}{2^{N-1} \sin^N \frac{x}{2}} + \sum_{k=0}^{N-2} \frac{\Delta^k a_n}{2^{k+1} \sin^{k+1} \frac{x}{2}}. \quad (1.36)$$

for $x \in (0, 2\pi)$ and $n \in \mathbb{N}_0$.

PROOF. We define the functions $S_n^{(j)}(x)$ and $S(x)$ as before. Then, because of (1.35) and (1.32), it follows that for $n \geq 0$

$$\begin{aligned} \left| \sum_{k=n}^{\infty} a_k e^{ikx} \right| &= |S(x) - S_{n-1}(x)| \\ &\leq \left| S(x) - S_{n+N-2}^{(N-1)}(x) \right| + \sum_{k=0}^{N-2} \left| S_{n+k}^{(k+1)}(x) - S_{n+k-1}^{(k)}(x) \right| \\ &\leq \frac{\Delta^{N-1} a_n}{2^{N-1} \sin^N \frac{x}{2}} + \sum_{k=0}^{N-2} \frac{\Delta^k a_n}{2^{k+1} \sin^{k+1} \frac{x}{2}}. \end{aligned}$$

□

The question that arises at this point is whether Lemma 1.10 is really an improvement of inequality (1.26) and if it will be of any practical use. Admittedly, it seems very likely that both questions have to be answered negatively for large N . For small N , however, Lemma 1.10 can be considerably better than inequality (1.26). For instance, it is easy to check that for $N = 2$ (1.36) gives a better estimate than (1.26) if

$$1 - \frac{a_{n+1}}{a_n} < \sin \frac{x}{2}.$$

From this relation one readily sees that for $N = 2$ the set of $x \in (0, 2\pi)$ for which (1.36) is stronger than (1.26) becomes the larger the slower the a_n decrease.

In order to illustrate the advantages of Lemma 1.10 with a concrete example, we will consider the problem of finding a polynomial lower bound for Vietoris' cosine polynomials $\tau_n(x)$. In other words, we will look for a positive algebraic polynomial p of lowest degree such that

$$\tau_n(x) \geq p(x) \quad \text{for all } n \in \mathbb{N}_0, x \in (0, \pi). \quad (1.37)$$

In [AK07] it is shown that such a polynomial has to be of degree 2 and that any polynomial p of degree 2 that satisfies (1.37) has to be of the form $a(x - \pi)^2$ with

$$0 < a \leq a^* := \min_{x \in (0, \pi)} \frac{\tau_6(x)}{(x - \pi)^2} = 0.1229 \dots$$

It is still unknown, however, whether the inequality

$$\tau_n(x) > p(x) := a^*(x - \pi)^2 \quad \text{for } n \in \mathbb{N}, x \in (0, \pi) \quad (1.38)$$

is true, i.e. whether the polynomial p is really a lower bound for the cosine polynomials $\tau_n(x)$.

In a similar way as in the parts (1), (2), and (4) of the proof of Theorem 1.3 one can show that (1.38) holds for all $n \in \mathbb{N}$ and $x \in (0, \frac{\pi}{n}] \cup [\frac{3\pi}{8}, \pi)$, but an adaptation of part (3) of the proof of Theorem 1.3 in order to prove (1.38) for $x \in (\frac{\pi}{n}, \frac{3\pi}{8})$ does not seem to be possible:

For Vietoris' coefficients $\{c_n\}_{n \in \mathbb{N}_0}$, we obtain

$$\tau_n(x) \geq \sqrt{\frac{1}{2} \cot \frac{x}{2}} - \frac{c_{n+1}}{\sin \frac{x}{2}}$$

for $n \in \mathbb{N}$ and $x \in (0, \pi)$ by taking the real part of inequality (1.26). Hence, in order to prove (1.38) for $x \in (\frac{\pi}{n}, \frac{3\pi}{8})$ it will be enough to verify that

$$h_n(x) := \sqrt{\sin x} - 2c_{n+1} - 2 \sin \frac{x}{2} p(x) > 0$$

for $x \in (\frac{\pi}{n}, \frac{3\pi}{8})$. Numerical computation shows, however, that $h_n(\frac{\pi}{n}) < 0$ for $n \leq 440$.

This may be considerably improved by employing the idea that led to Lemma 1.10 (since the sequence c_k is not monotonic of order 2 we can not apply Lemma 1.10 directly). If $S_n(x) := \tau(x) + i\sigma_n(x)$, $x \in (0, \pi)$, then Lemma 1.9 shows that

$$\begin{aligned} S_n^{(1)}(x) &= \frac{e^{-i(\frac{\pi+x}{2})}}{2 \sin \frac{x}{2}} \left(-1 + \sum_{k=1}^n (c_{k-1} - c_k) e^{ikx} \right) \\ &= \frac{e^{-i(\frac{\pi+x}{2})}}{2 \sin \frac{x}{2}} \left(-1 + \sum_{k=1}^{\lfloor n/2 \rfloor} (c_{2k-1} - c_{2k}) e^{i2kx} \right). \end{aligned}$$

Here, for any real number x , $\lfloor x \rfloor$ denotes the largest integer n that satisfies $n \leq x$. Since $\{c_n\}_{n \in \mathbb{N}_0}$ is a zero sequence, it follows from (1.32) that

$$\lim_{n \rightarrow \infty} S_n^{(1)}(x) = \lim_{n \rightarrow \infty} S_n(x) = (1+i) \sqrt{\frac{1}{2} \cot \frac{x}{2}} =: S(x).$$

Since it is easy to check that

$$c_{2k-1} - c_{2k} = \frac{\left(\frac{1}{2}\right)_{k-1}}{(k-1)!} - \frac{\left(\frac{1}{2}\right)_k}{k!} = \frac{1}{2} \frac{\left(\frac{1}{2}\right)_{k-1}}{k!}, \quad k \in \mathbb{N},$$

is a non-negative decreasing zero sequence, (1.26) gives

$$\left| S\left(\frac{x}{2}\right) - S_n^{(1)}\left(\frac{x}{2}\right) \right| \leq \frac{c_{2\lfloor n/2 \rfloor + 1} - c_{2\lfloor n/2 \rfloor + 2}}{2 \sin \frac{x}{2} \sin \frac{x}{4}}$$

for $x \in (0, 2\pi)$. Applying this relation and (1.32) we obtain

$$\begin{aligned} |S(x) - S_{n-1}(x)| &\leq |S(x) - S_n^{(1)}(x)| + |S_n^{(1)}(x) - S_{n-1}(x)| \\ &\leq \frac{c_{2\lfloor n/2 \rfloor + 1} - c_{2\lfloor n/2 \rfloor + 2}}{2 \sin \frac{x}{2} \sin x} + \frac{c_n}{2 \sin \frac{x}{2}} \end{aligned}$$

for $x \in (0, \pi)$. Taking the real part of this inequality, it follows that $\tau_n(x) \geq p(x)$ holds for all $x \in (0, \pi)$ for which

$$g_n(x) := \sqrt{\frac{1}{2} \cot \frac{x}{2}} - \frac{c_{2\lfloor (n+1)/2 \rfloor + 1} - c_{2\lfloor (n+1)/2 \rfloor + 2}}{2 \sin \frac{x}{2} \sin x} - \frac{c_{n+1}}{2 \sin \frac{x}{2}} - p(x) \geq 0.$$

Numerical computation indicates that $g_n(x) \geq 0$ in $(\frac{\pi}{n}, \frac{3\pi}{8})$ for all $n \geq 21$.

Unfortunately, no proof has so far been found that shows that $g_n(x) \geq 0$ in $(\frac{\pi}{n}, \frac{3\pi}{8})$ for all n larger than 21 (or a number that is only slightly larger than 21). This, however, is largely due to the fact that the functions $g_n(x)$ contain both trigonometric and algebraic terms. For pure positivity problems of trigonometric sums (i.e. for problems in which one is only interested in the positivity of certain trigonometric polynomials – and not in finding a lower bound by a positive algebraic polynomial) this difficulty should not appear and one could therefore expect to obtain much better estimates with Lemma 1.10 (for $N = 2$) than with inequality (1.26).

On a Conjecture for Trigonometric Sums and Starlike Functions

Let \mathcal{A} be the set of functions f that are analytic in the unit disk $\mathbb{D} := \{z \in \mathbb{C} : |z| < 1\}$ of the complex plane \mathbb{C} . Let \mathcal{A}_0 and \mathcal{A}_1 denote the set of functions $f \in \mathcal{A}$ that are normalized by $f(0) = f'(0) - 1 = 0$ and $f(0) = 1$, respectively. For every function $f \in \mathcal{A}$ we denote by

$$s_n(f, z) := \sum_{k=0}^n a_k z^k$$

the n th partial sum of its power series representation

$$f(z) = \sum_{k=0}^{\infty} a_k z^k$$

around the origin. For two functions $f, g \in \mathcal{A}$ we say that f is *subordinate* to g and write $f \prec g$ if there exists an $\omega \in \mathcal{A}$ satisfying $|\omega(z)| \leq |z|$ for $z \in \mathbb{D}$ such that $f = g \circ \omega$ in \mathbb{D} . It is clear that in such a case $f(0) = g(0)$ and $f(\mathbb{D}) \subseteq g(\mathbb{D})$ and that these two conditions are also sufficient for $f \prec g$ if g is univalent in \mathbb{D} (set $\omega := g^{-1} \circ f$).

The class \mathcal{S}_λ^* of functions that are *starlike of order* $\lambda \leq 1$ is defined to be the set of all functions $f \in \mathcal{A}_0$ for which

$$\operatorname{Re} \frac{zf'(z)}{f(z)} > \lambda, \quad z \in \mathbb{D}. \quad (2.1)$$

Since $zf'(z)/f(z) = 1$ at $z = 0$ for all $f \in \mathcal{A}_0$, it is clear that $\mathcal{S}_1^* = \{z\}$. For $\lambda \in \mathbb{C}$ we have

$$f_\lambda(z) := \frac{z}{(1-z)^\lambda} \in \mathcal{A}_0, \quad (2.2)$$

if we choose the branch of the logarithm for which $f'_\lambda(0) = 1$. It is easy to check that for $\lambda \leq 1$ the function $f_{2-2\lambda}$ belongs to \mathcal{S}_λ^* .

In [RS00] (see also [Rus78]) Ruscheweyh and Salinas proved that for all $\lambda \in [\frac{1}{2}, 1)$

$$\frac{s_n(f, z)}{f(z)} \prec \frac{z}{f_{2-2\lambda}(z)} \quad \text{for } f \in \mathcal{S}_\lambda^*. \quad (2.3)$$

This result led to two different directions of research.

First, in [RS04] Ruscheweyh and Salinas proved that if $f = f_{2-2\lambda}$, then (2.3) remains true for $\lambda \in (1, \frac{3}{2}]$, and showed that this extension of (2.3) leads to a new, function theoretic proof of Vietoris' inequalities (for odd n only, though). This seems to be of particular importance, since until then all known proofs of Vietoris' theorem used exclusively real methods, completely ignoring the fact that Vietoris' inequalities are nothing else than a statement concerning the mapping behavior of a certain class of complex polynomials.

Second, as noted in [RS00], (2.3) implies that for $\rho \in (0, 1]$

$$|\arg s_n(f, z)| \leq \rho\pi, \quad \text{for } z \in \mathbb{D}, n \in \mathbb{N}, zf \in \mathcal{S}_{1-\frac{\rho}{2}}^*. \quad (2.4)$$

Even though this relation is best possible for $\rho = 1$ (for every $\rho > 1$ the function $s_1(f_\rho/z, 1)$ has a zero in the unit disk), Koumandos and Ruscheweyh showed in [KR06] that this is not the case in general: they found that the largest possible $\mu \in (0, 1]$, for which $|\arg s_n(f, z)| < \frac{\pi}{2}$ in \mathbb{D} for all $zf \in \mathcal{S}_{1-\frac{\mu}{2}}^*$, is equal to $1 - \alpha_0$, where α_0 is the solution of (1.9).

In order to find a best possible extension of (2.4), in [KR07] Koumandos and Ruscheweyh proposed the following conjecture concerning the partial sums

$$s_n^\mu(z) := s_n\left(\frac{f_\mu}{z}, z\right) = \sum_{k=0}^n \frac{(\mu)_k}{k!} z^k, \quad \mu \in (0, 1], n \in \mathbb{N}_0,$$

of the functions f_μ/z .

CONJECTURE 2.1. For $\rho \in (0, 1]$ define $\mu(\rho)$ as the maximal number such that

$$(1-z)^\rho s_n^\mu(z) \prec \left(\frac{1+z}{1-z}\right)^\rho$$

holds for all $n \in \mathbb{N}$ and $0 < \mu \leq \mu(\rho)$. Then for all $\rho \in (0, 1]$ the number $\mu(\rho)$ is equal to the unique solution $\mu^*(\rho)$ in $(0, 1]$ of the equation

$$\int_0^{(\rho+1)\pi} \frac{\sin(t - \rho\pi)}{t^{1-\mu}} dt = 0.$$

In [KR07] it is explained that the truth of this conjecture would imply several other new and interesting results. One of those would be the following extension of (2.4).

CONJECTURE 2.2. If $\rho \in (0, 1]$, then for all $0 < \mu \leq \mu^*(\rho)$ we have

$$|\arg s_n(f, z)| \leq \rho\pi, \quad \text{for all } z \in \mathbb{D}, n \in \mathbb{N}, zf \in \mathcal{S}_{1-\frac{\mu}{2}}^*.$$

Since in [KR07] it is also shown that

$$\rho \leq \mu(\rho) \leq \mu^*(\rho) \quad \text{for } \rho \in (0, 1], \quad (2.5)$$

it is clear that Conjecture 2.2, once established, represents an extension of (2.4).

In this chapter we will present some new results concerning Conjectures 2.1 and 2.2. Specifically, we will show that Conjecture 2.2 cannot hold if $\mu^*(\rho)$ is replaced by any larger number. This implies that Conjecture 2.2, once verified, is a best possible extension of (2.4). We will also prove that Conjecture 2.1 is equivalent to the positivity of a certain family of trigonometric sums and then use this result in order to verify Conjecture 2.1 for all ρ in a neighborhood of $\frac{1}{5}$.

2.1. Some New Properties of the Function $\mu^*(\rho)$

In this section we will give rigid proofs of some elementary properties of the function $\mu^*(\rho)$. Among other things, we will show that in Conjecture 2.2 the number $\mu^*(\rho)$ can not be replaced by any larger number.

For every $\rho \in (0, 1]$ the number $\mu^*(\rho)$ is defined as the unique solution in $(0, 1]$ of the equation

$$F(\rho, \mu) := \int_0^{(\rho+1)\pi} \frac{\sin(t - \rho\pi)}{t^{1-\mu}} dt = 0.$$

The existence and uniqueness of such a solution follow readily from the next lemma.

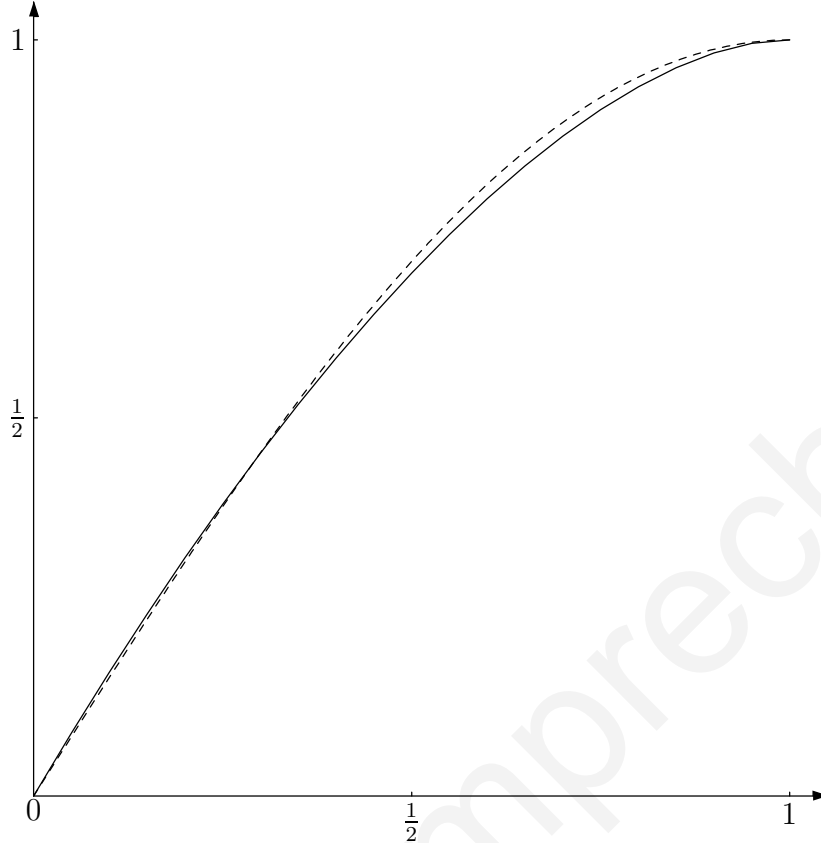

FIGURE 2.1. The graph of the function $\mu^*(\rho)$. The graph of the function $\sin \frac{\rho\pi}{2}$, $\rho \in [0, 1]$, is dashed. (The graphs in this thesis have been created by using the KETpic package for Maple [ket].)

LEMMA 2.3. *For every $\rho \in (0, 1)$ the function $\mu \mapsto F(\rho, \mu)$ is strictly increasing in $(0, 1)$ with $F(\rho, 0) = -\infty$ and $F(\rho, 1) > 0$.*

The case $\rho = \frac{1}{2}$ of this lemma is shown in [Zyg02, V. 2.29]. As mentioned in [KR07, Lem. 1], the proof of this special case can be easily modified in order to obtain a proof of the above lemma for all $\rho \in (0, 1]$.

Numerical evidence indicates that the function $\mu^*(\rho)$ is very similar to the function $\sin \frac{\rho\pi}{2}$ (cf. Figure 2.1). In particular, we expect $\mu^*(\rho)$ to be an analytic, increasing and concave function on $(0, 1]$. However, besides Lemma 2.3 and relation (2.5), no other properties of the function $\mu^*(\rho)$ seem to be verified in the literature. In this section we will give rigid proofs of some elementary properties of $\mu^*(\rho)$. An important tool in our considerations will be the fact that

$$\int_0^a \frac{\sin t}{t^{1-b}} dt > 0 \quad \text{for all } a > 0, b \in (0, 1). \quad (2.6)$$

This follows easily from the observation that for every $b \in (0, 1)$ the function $t^{b-1} \sin t$ is oscillating in $(0, \infty)$ with decreasing amplitude.

As our first result we prove two of the above suggested properties of $\mu^*(\rho)$. The concavity of $\mu^*(\rho)$ remains an open problem.

LEMMA 2.4. *The function $\mu^*(\rho)$ is analytic and strictly increasing in $(0, 1)$.*

PROOF. The three integrals $F(\rho, \mu)$,

$$F_\rho(\rho, \mu) := \frac{\partial F}{\partial \rho}(\rho, \mu) = -\pi \int_0^{(\rho+1)\pi} \frac{\cos(t - \rho\pi)}{t^{1-\mu}} dt, \quad (2.7)$$

and

$$F_\mu(\rho, \mu) := \frac{\partial F}{\partial \mu}(\rho, \mu) = \int_0^{(\rho+1)\pi} \frac{\sin(t - \rho\pi)}{t^{1-\mu}} \log t \, dt,$$

exist for all ρ and μ in the half-plane $\mathbb{H} := \{z \in \mathbb{C} : \operatorname{Re} z > 0\}$. Hence, the function $F(\rho, \mu)$ is analytic in \mathbb{H}^2 [JP08, Thm. 1.7.13] and therefore also real analytic in $(0, 1)^2$. Since $F_\mu(\rho, \mu) > 0$ for $(\rho, \mu) \in (0, 1)^2$ by Lemma 2.3, it thus follows from the implicit function theorem for real analytic functions [KP02, Thm. 2.3.5] that $\mu^*(\rho)$ is an analytic function in $(0, 1)$ with

$$(\mu^*)'(\rho) = -\frac{F_\rho(\rho, \mu^*(\rho))}{F_\mu(\rho, \mu^*(\rho))}.$$

(2.7) and the next lemma thus show that $\mu^*(\rho)$ is strictly increasing in $(0, 1)$. \square

LEMMA 2.5. *For all $\rho \in (0, 1)$ we have $G(\rho, \mu^*(\rho)) > 0$, where*

$$G(\rho, \mu) := \int_0^{(\rho+1)\pi} \frac{\cos(t - \rho\pi)}{t^{1-\mu}} \, dt, \quad (\rho, \mu) \in \mathbb{H}^2.$$

PROOF. Because of (2.6) we have

$$G\left(\frac{1}{2}, \mu^*\left(\frac{1}{2}\right)\right) = \int_0^{\frac{3}{2}\pi} \frac{\sin t}{t^{1-\mu^*(\frac{1}{2})}} \, dt > 0.$$

Since with $\mu^*(\rho)$ also $G(\rho, \mu^*(\rho))$ is continuous in $(0, 1)$, it follows that if there is a $\rho \in (0, 1)$ for which $G(\rho, \mu^*(\rho)) < 0$, then there must also be a $\rho \in (0, 1)$ for which $G(\rho, \mu^*(\rho)) = 0$. Since by definition

$$F(\rho, \mu^*(\rho)) = \int_0^{(\rho+1)\pi} \frac{\sin(t - \rho\pi)}{t^{1-\mu^*(\rho)}} \, dt = 0$$

for all $\rho \in (0, 1)$, we then obtain

$$e^{-i\rho\pi} \int_0^{(\rho+1)\pi} \frac{e^{it}}{t^{1-\mu^*(\rho)}} \, dt = G(\rho, \mu^*(\rho)) + iF(\rho, \mu^*(\rho)) = 0.$$

But this means that

$$\int_0^{(\rho+1)\pi} \frac{\sin t}{t^{1-\mu^*(\rho)}} \, dt = 0,$$

which is a contradiction to (2.6). Hence, $G(\rho, \mu^*(\rho))$ must be positive for all $\rho \in (0, 1)$. \square

By (2.5) and the definition of $\mu^*(\rho)$ we have the estimate $\rho \leq \mu^*(\rho) \leq 1$ for $\rho \in (0, 1]$. In our next result we give a better upper estimate for $\mu^*(\rho)$ when $\rho \in (0, \frac{1}{2})$.

LEMMA 2.6. *We have $\mu^*(\rho) < 2\rho$ for $\rho \in (0, \frac{1}{2})$.*

PROOF. Because of Lemma 2.3 it will be enough to show that

$$\int_0^{(\rho+1)\pi} \frac{\sin(t - \rho\pi)}{t^{1-2\rho}} \, dt > 0,$$

for $\rho \in (0, \frac{1}{2})$ in order to prove the assertion.

To this end, we make use of the two easily verified inequalities

$$x \leq \sin x \quad \text{and} \quad -\frac{x}{\pi}(x - \pi) \leq \sin x, \quad (2.8)$$

which hold for $x \leq 0$ and $x \in [0, \pi]$, respectively. We obtain

$$\begin{aligned} \int_0^{(\rho+1)\pi} \frac{\sin(t - \rho\pi)}{t^{1-2\rho}} dt &\geq \int_0^{\rho\pi} \frac{t - \rho\pi}{t^{1-2\rho}} dt - \int_{\rho\pi}^{(\rho+1)\pi} \frac{(t - \rho\pi)(t - (\rho+1)\pi)}{\pi t^{1-2\rho}} dt \\ &= \frac{(\pi\rho)^{2\rho+1}}{2(\rho+1)(2\rho+1)} > 0 \end{aligned}$$

for $\rho \in (0, \frac{1}{2})$. □

Note that for $a > 0$

$$\left[\int_0^{\rho\pi} \frac{t - \rho\pi}{t^{1-a\rho}} dt - \int_{\rho\pi}^{(\rho+1)\pi} \frac{(t - \rho\pi)(t - (\rho+1)\pi)}{\pi t^{1-a\rho}} dt \right]_{\rho=0} = \frac{\pi}{2a}(a-2).$$

The estimate $\mu^*(\rho) < 2\rho$ is therefore the best possible that we can obtain if we use the inequalities (2.8).

The fact that, by Lemma 2.3, $\frac{d}{d\mu}F(\rho, \mu) > 0$ for all $(\rho, \mu) \in (0, 1)^2$ was of special importance in all the results concerning the function $\mu^*(\rho)$ that we have presented so far. Since

$$\frac{d}{d\rho}F(\rho, \mu) = -\pi G(\rho, \mu),$$

the next lemma gives some information about the sign of $\frac{d}{d\rho}F(\rho, \mu)$ when $(\rho, \mu) \in (0, 1)^2$.

LEMMA 2.7. *If $\rho \in (0, \frac{1}{2}]$, then $G(\rho, \mu) > 0$ for all $\mu \in (0, \mu^*(\rho + \frac{1}{2}))$. If $\rho \in (\frac{1}{2}, 1]$, then $G(\rho, \mu) < 0$ for all $\mu \in (0, \mu^*(\rho - \frac{1}{2}))$.*

PROOF. Let $\rho \in (0, \frac{1}{2}]$ and $\mu \in (0, \mu^*(\rho + \frac{1}{2}))$. Then

$$G(\rho, \mu) = - \int_0^{(\rho+1)\pi} \frac{\sin(t - (\rho + \frac{1}{2})\pi)}{t^{1-\mu}} dt,$$

and therefore, by Lemma 2.3,

$$\begin{aligned} G(\rho, \mu) &= - \int_0^{(\rho+\frac{3}{2})\pi} \frac{\sin(t - (\rho + \frac{1}{2})\pi)}{t^{1-\mu}} dt + \int_{(\rho+1)\pi}^{(\rho+\frac{3}{2})\pi} \frac{\sin(t - (\rho + \frac{1}{2})\pi)}{t^{1-\mu}} dt \\ &> \int_{(\rho+1)\pi}^{(\rho+\frac{3}{2})\pi} \frac{\sin(t - (\rho + \frac{1}{2})\pi)}{t^{1-\mu}} dt > 0, \end{aligned}$$

since $\sin(t - (\rho + \frac{1}{2})\pi) > 0$ for $t \in ((\rho+1)\pi, (\rho + \frac{3}{2})\pi)$.

The other asserted relation can be shown in a similar way and thus the proof is complete. □

In our final result of this section we show that Conjecture 2.2, once verified, is a best possible extension of (2.4).

LEMMA 2.8. *Let $\rho \in (0, 1]$. There is no number $\mu \in (\mu^*(\rho), 1)$ such that*

$$|\arg s_n(f, z)| \leq \rho\pi, \quad \text{for all } z \in \mathbb{D}, n \in \mathbb{N}, zf \in \mathcal{S}_{1-\frac{\mu}{2}}^*.$$

PROOF. Let $\rho \in (0, 1)$ and $\mu \in (\mu^*(\rho), 1)$. Since $zf_\mu \in \mathcal{S}_{1-\frac{\mu}{2}}^*$, it will be enough to prove that

$$s_n^\mu(e^{i(\rho+1)\frac{\pi}{n}}) \in S := \{z \in \mathbb{C} \setminus \{0\} : \arg z \in (\rho\pi, \pi)\} \quad \text{for large } n \in \mathbb{N}. \quad (2.9)$$

As explained in the proof of [KR07, Lem. 1], we have

$$\lim_{n \rightarrow \infty} \left(\frac{\theta}{n}\right)^\mu \sum_{k=0}^n \frac{(\mu)_k}{k!} e^{i \frac{k\theta}{n}} = \frac{1}{\Gamma(\mu)} \int_0^\theta \frac{e^{it}}{t^{1-\mu}} dt$$

for $\theta > 0$ and $\mu \in (0, 1]$. In order to obtain (2.9) it will therefore suffice to show that

$$A := \int_0^{(\rho+1)\pi} \frac{e^{it}}{t^{1-\mu}} dt \in S.$$

This relation is obviously equivalent to the two inequalities

$$\operatorname{Im} A = \int_0^{(\rho+1)\pi} \frac{\sin t}{t^{1-\mu}} dt > 0 \quad (2.10)$$

and

$$\operatorname{Im} e^{-i\rho\pi} A = \int_0^{(\rho+1)\pi} \frac{\sin(t - \rho\pi)}{t^{1-\mu}} dt > 0. \quad (2.11)$$

Since $\mu \in (\mu^*(\rho), 1)$, (2.10) and (2.11) follow from (2.6) and Lemma 2.3, respectively. \square

2.2. On the Conjecture of Koumandos and Ruscheweyh

We will show that Conjecture 2.1 of Koumandos and Ruscheweyh is equivalent to the positivity of a certain family of trigonometric sums and then use this result in order to prove the conjecture for all ρ in a neighborhood of $\frac{1}{5}$.

Until now Conjecture 2.1 of Koumandos and Ruscheweyh has been verified for $\rho = \frac{1}{4}$ [KL09a] and $\rho = \frac{1}{2}$ [KR07]. In both cases, some more or less complicated algebraic transformations were used in order to show that, for $\rho = \frac{1}{4}$ and $\rho = \frac{1}{2}$, Conjecture 2.1 is equivalent to the non-negativity

$$\sigma_n(\rho, \mu^*(\rho), \theta) \geq 0, \quad \theta \in [0, \pi], n \in \mathbb{N}, \quad (2.12)$$

of the trigonometric sums

$$\sigma_n(\rho, \mu, \theta) := \sum_{k=0}^n \frac{(\mu)_k}{k!} \sin[(2k + \rho)\theta], \quad \theta \in \mathbb{R}, (\mu, \rho) \in (0, 1]^2.$$

As shown in [KR07], for $\rho = \frac{1}{2}$ inequality (2.12) is equivalent to Koumandos' extension of Vietoris' inequalities from [Kou07] (cf. the introduction in Chapter 1). Koumandos' method for proving the positivity of trigonometric sums with coefficient sequences of the form $\left\{\frac{(\mu)_n}{n!}\right\}_{n \in \mathbb{N}_0}$ from [Kou07] was also used in [KL09a] in order to prove (2.12) for $\rho = \frac{1}{4}$.

In principle, Koumandos' method should lead to a proof of inequality (2.12) for all $\rho \in (0, 1]$ and therefore the following is perhaps the most important result of this chapter.

LEMMA 2.9. *Let $(\mu, \rho) \in (0, 1]^2$ and $n \in \mathbb{N}$. Then*

$$(1 - z)^\rho s_n^\mu(z) \prec \left(\frac{1+z}{1-z}\right)^\rho \quad (2.13)$$

holds if, and only if,

$$\sigma_n(\rho, \mu, \theta) \geq 0 \quad \text{for all } \theta \in [0, \pi]. \quad (2.14)$$

PROOF. It follows from the definition of subordination that (2.13) is equivalent to the two inequalities

$$\operatorname{Im} [e^{i\rho\pi/2}(1-z)^\rho s_n^\mu(z)] > 0, \quad z \in \mathbb{D}, \quad (2.15)$$

and

$$\operatorname{Im} [e^{-i\rho\pi/2}(1-z)^\rho s_n^\mu(z)] < 0, \quad z \in \mathbb{D}. \quad (2.16)$$

For $z = e^{2i\theta}$, $\theta \in [0, \pi]$, we have

$$(1-z)^\rho s_n^\mu(z) = (2 \sin \theta)^\rho e^{-i\rho\pi/2} \sum_{k=0}^n \frac{(\mu)_k}{k!} e^{i(2k+\rho)\theta},$$

and therefore it follows from the minimum principle of harmonic functions that (2.15) and (2.16) are equivalent to

$$\sigma_n(\rho, \mu, \theta) = \sum_{k=0}^n \frac{(\mu)_k}{k!} \sin[(2k+\rho)\theta] \geq 0, \quad \theta \in [0, \pi],$$

and

$$-\sigma_n(\rho, \mu, \pi - \theta) = \sum_{k=0}^n \frac{(\mu)_k}{k!} \sin[(2k+\rho)\theta - \rho\pi] \leq 0, \quad \theta \in [0, \pi],$$

respectively. \square

As this lemma shows, Conjecture 2.1 holds for every $\rho \in (0, 1]$ for which the following conjecture is true.

CONJECTURE 2.10. *For all $\rho \in (0, 1]$ we have*

$$\sigma_n(\rho, \mu^*(\rho), \theta) > 0 \quad \text{for all } n \in \mathbb{N}, \theta \in (0, \pi]. \quad (2.17)$$

This conjecture is slightly stronger than Conjecture 2.1. This is because, as one can easily see from the proof of Lemma 2.9, Conjecture 2.10 implies that

$$|\arg(1-z)^\rho s_n^\mu(z)| < \frac{\rho\pi}{2} \quad \text{for } \rho \in (0, 1], \mu \in (0, \mu^*(\rho)], z \in \overline{\mathbb{D}} \setminus \{1\},$$

while Conjecture 2.1 only gives us

$$|\arg(1-z)^\rho s_n^\mu(z)| \leq \frac{\rho\pi}{2} \quad \text{for } \rho \in (0, 1], \mu \in (0, \mu^*(\rho)], z \in \overline{\mathbb{D}} \setminus \{1\}.$$

Note also that (2.5) and Lemma 2.9 imply that we cannot have $\sigma_n(\rho, \mu, \theta) > 0$ for all $\theta \in (0, \pi]$ and $n \in \mathbb{N}$ if $\mu > \mu^*(\rho)$. Once verified, Conjecture 2.10 will therefore represent a family of new sharp trigonometric inequalities.

In the remainder of this chapter we will present a proof of Conjecture 2.10 – and thus also of Conjecture 2.1 – for all ρ in a neighborhood of $\frac{1}{5}$. In our proof we will apply the above mentioned method of Koumandos [KR06, Kou07, KR07, KL09a] for proving the positivity of trigonometric polynomials with coefficient sequences of the form $\{\frac{(\mu)_k}{k!}\}_{k \in \mathbb{N}_0}$. The crucial idea in this method is to estimate the sequence $\{\frac{(\mu)_k}{k!}\}_{k \in \mathbb{N}_0}$ in terms of the sequence $\{k^{\mu-1}\}_{k \in \mathbb{N}}$.

More explicitly, setting

$$\Delta_k := \frac{1}{k^{1-\mu}} \left(\frac{1}{\Gamma(\mu)} - \frac{(\mu)_k}{k! k^{\mu-1}} \right), \quad \text{for } k \in \mathbb{N}, \mu \in (0, 1),$$

we have [KR07, Sec. 3.3]

$$\sum_{k=0}^n \frac{(\mu)_k}{k!} e^{2ik\theta} = \sum_{k=0}^{\infty} \frac{(\mu)_k}{k!} e^{2ik\theta} - \frac{1}{\Gamma(\mu)} \sum_{k=n+1}^{\infty} \frac{1}{k^{1-\mu}} e^{2ik\theta} + \sum_{k=n+1}^{\infty} \Delta_k e^{2ik\theta}. \quad (2.18)$$

The first summand on the right-hand side of this equation sums to $e^{i\mu(\frac{\pi}{2}-\theta)}(2\sin\theta)^{-\mu}$ and the second can essentially be estimated by a method developed in [BWW93]. It is easy to see [KR06, Lem. 2] that for $\mu \in (0, 1)$ the sequence $\{\Delta_k\}_{k \in \mathbb{N}}$ is positive and strictly decreasing. An application of (1.26) thus shows that

$$\left| \sum_{k=n+1}^{\infty} \Delta_k e^{2ik\theta} \right| \leq \frac{\Delta_{n+1}}{\sin\theta}. \quad (2.19)$$

Therefore every estimate for the coefficients Δ_k will also lead to an estimate of the third summand on the right-hand side of (2.18).

In order to obtain such an estimate, note that by (1.5)

$$k^{2-\mu}\Gamma(\mu)\Delta_k = \xi(k), \quad (2.20)$$

where

$$\xi(x) := x - \frac{\Gamma(x+\mu)}{\Gamma(x+1)}x^{2-\mu}, \quad x > 0.$$

It is shown in [Kou08] that

$$\lim_{x \rightarrow \infty} \xi(x) = \frac{\mu(1-\mu)}{2}, \quad \mu \in (0, 1),$$

and in [Kou08] and [KL09a] that $\xi'(x)$ is completely monotonic in $x > 0$ for $\mu \in [\frac{1}{3}, 1)$ (for the definition of completely monotonic functions we refer to the next chapter). Since completely monotonic functions are in particular positive, it thus follows that

$$\xi(x) < \frac{\mu(1-\mu)}{2}, \quad \text{for } x > 0, \mu \in \left[\frac{1}{3}, 1\right), \quad (2.21)$$

which, because of (2.19) and (2.20), implies that

$$\left| \sum_{k=n+1}^{\infty} \Delta_k e^{2ik\theta} \right| \leq \frac{\mu(1-\mu)}{2\sin\theta} \frac{1}{\Gamma(\mu)} \frac{1}{(n+1)^{2-\mu}} \quad (2.22)$$

for all $\theta \in (0, \pi)$, $n \in \mathbb{N}$, and $\mu \in [\frac{1}{3}, 1)$ [KR07, Kou08, KL09a].

Therefore for $\mu \in [\frac{1}{3}, 1)$ the relation (2.18) leads to an estimate of the trigonometric polynomials $\sum_{k=0}^n \frac{(\mu)_k}{k!} e^{2ik\theta}$ in terms of a few elementary expressions (this estimate is described in detail in Lemma 2.12 below).

Until now, however, no such estimate has been found in the case $\mu \in (0, \frac{1}{3})$. The above reasoning cannot be applied when μ lies in this range, since, as shown in [KL09a], for $\mu \in (0, \frac{1}{3})$ the function $\xi'(x)$ is negative for x close to ∞ and positive for x close to 0. Our next result leads to some new way of dealing with this problem.

LEMMA 2.11. *Let $x \geq 1$. Then the function*

$$\mu \mapsto \xi(x) = x - \frac{\Gamma(x+\mu)}{\Gamma(x+1)}x^{2-\mu}, \quad \mu \in \left(0, \frac{2}{5}\right),$$

is increasing.

PROOF. We have

$$\frac{d}{d\mu} \xi(x) = x^{2-\mu} \frac{\Gamma(x+\mu)}{\Gamma(x+1)} (\log x - \psi(x+\mu)),$$

where the so-called *psi function*

$$\psi(x) := \frac{\Gamma'(x)}{\Gamma(x)}, \quad x > 0,$$

is the logarithmic derivative of the gamma function. By [AS65, 6.3.21]

$$\psi(x) = \log x - \frac{1}{2x} - 2 \int_0^\infty \frac{t}{(t^2 + x^2)(e^{2\pi t} - 1)} dt \quad \text{for } x > 0,$$

and hence it will be enough to show that

$$h(\mu) := \frac{1}{2(x + \mu)} - \log \left(1 + \frac{\mu}{x} \right) > 0 \quad \text{for } x \geq 1, \mu \in \left(0, \frac{2}{5} \right) \quad (2.23)$$

in order to prove the assertion. Since

$$h'(\mu) = -\frac{1 + 2x + 2\mu}{2(x + \mu)^2}$$

is negative for all $x > 1$ and $\mu \in (0, \frac{2}{5})$ and since it is easy to verify that $h(\frac{2}{5})$ is positive for all $x > 1$, the proof of the lemma is complete. \square

Because of this lemma and (2.21), for $\mu \leq \frac{1}{3}$ and $x \geq 1$ we have

$$x - \frac{\Gamma(x + \mu)}{\Gamma(x + 1)} x^{2-\mu} \leq x - \frac{\Gamma(x + \frac{1}{3})}{\Gamma(x + 1)} x^{5/3} \leq \frac{1}{9} \quad (2.24)$$

It therefore follows from (2.19), (2.20) and (2.22) that

$$\left| \sum_{k=n+1}^\infty \Delta_k e^{2ik\theta} \right| \leq \frac{\widehat{\mu}(1 - \widehat{\mu})}{2 \sin \theta} \frac{1}{\Gamma(\mu)} \frac{1}{(n + 1)^{2-\mu}} \quad (2.25)$$

for all $\theta \in (0, \pi)$, $n \in \mathbb{N}$, and $\mu \in (0, 1)$. Here and for the rest of this chapter we set $\widehat{x} := \max(x, \frac{1}{3})$ for a real number x .

We thus obtain the following extension of [KL09a, Lem. 1], which was the crucial result in the proof of the case $\rho = \frac{1}{4}$ of Conjecture 2.10 in [KL09a]. [KL09a, Lem. 1] was derived from [KR07, Kou08], where it appeared in a (more or less) disguised form.

LEMMA 2.12. *Let $c(\theta)$ be a real integrable function of $\theta \in \mathbb{R}$, $\mu \in (0, 1)$ and $0 < a < b \leq \frac{\pi}{2}$. Then for $f(\theta) = \sin \theta$ or $f(\theta) = \cos \theta$ we have for all $\theta \in [a, b]$ and $n \in \mathbb{N}$*

$$\begin{aligned} 2^\mu \theta^{\mu-1} \Gamma(\mu) \sum_{k=0}^n \frac{(\mu)_k}{k!} f(2k\theta + c(\theta)) &> \\ &> \kappa_n(\theta) - A_n - B_n - C_n + \Gamma(\mu) \left(2q(\theta) \frac{\sin \frac{\mu\theta}{2}}{\sin \theta} - r(\theta)s(\theta) \right), \end{aligned} \quad (2.26)$$

where

$$\begin{aligned} A_n &:= \frac{b}{\sin b} \frac{1 - \mu}{4n(2an)^{1-\mu}}, \quad B_n := \frac{b^2}{\sin^2 b} \frac{1 - \mu}{3n(2an)^{1-\mu}}, \\ C_n &:= \frac{\pi \widehat{\mu}(1 - \widehat{\mu})}{(2a(n + 1))^{2-\mu}}, \quad q(\theta) := f \left(\frac{\mu}{2}(\pi - \theta) + c(\theta) - \frac{\pi}{2} \right), \\ r(\theta) &:= f \left(\frac{\mu}{2}(\pi - 2\theta) + c(\theta) \right), \quad s(\theta) := \frac{1}{\sin \theta} \left[1 - \left(\frac{\sin \theta}{\theta} \right)^{1-\mu} \right] \end{aligned}$$

and

$$\kappa_n(\theta) := \frac{1}{\sin \theta} \int_0^{(2n+1)\theta} \frac{f(t + c(\theta))}{t^{1-\mu}} dt.$$

The function $s(\theta)$ is positive and increasing on $(0, \pi)$.

PROOF. By [KR07, (3.8)] we have

$$\sum_{k=0}^n \frac{(\mu)_k}{k!} e^{2ik\theta} = F(\theta) + \frac{1}{\Gamma(\mu)} \frac{\theta}{\sin \theta} \frac{1}{(2\theta)^\mu} \int_0^{(2n+1)\theta} \frac{e^{it}}{t^{1-\mu}} dt$$

$$- \frac{1}{\Gamma(\mu)} \frac{\theta}{\sin \theta} \left\{ \sum_{k=n+1}^{\infty} A_k(\theta) + \sum_{k=n+1}^{\infty} B_k(\theta) \right\} + \sum_{k=n+1}^{\infty} \Delta_k e^{2ik\theta},$$

with

$$F(\theta) := \sum_{k=0}^{\infty} \frac{(\mu)_k}{k!} e^{2ik\theta} - \frac{\theta}{\sin \theta} \frac{e^{i\mu\frac{\pi}{2}}}{(2\theta)^\mu}$$

and where

$$\left| \sum_{k=n+1}^{\infty} A_k(\theta) \right| < \frac{1-\mu}{8} \frac{1}{n^{2-\mu}},$$

$$\left| \sum_{k=n+1}^{\infty} B_k(\theta) \right| < \frac{\theta}{\sin \theta} \frac{1-\mu}{6} \frac{1}{n^{2-\mu}}$$

for $\theta \in (0, \pi)$ by [KR07, Prop. 1]. As in the proof of [KR07, Prop. 2] it follows that

$$F(\theta) = \frac{\theta^{1-\mu}}{2^\mu} \frac{e^{i\mu\frac{\pi}{2}}}{\sin \theta} \left\{ (e^{-i\mu\theta} - 1) - \left[1 - \left(\frac{\sin \theta}{\theta} \right)^{1-\mu} \right] e^{-i\mu\theta} \right\}.$$

Hence

$$2^\mu \theta^{\mu-1} F(\theta) e^{ic(\theta)} = 2e^{i(\frac{\mu}{2}(\pi-\theta)+c(\theta)-\frac{\pi}{2})} \frac{\sin \frac{\mu\theta}{2}}{\sin \theta} - s(\theta) e^{i(\frac{\mu}{2}(\pi-2\theta)+c(\theta))}$$

and thus (2.26) follows from (2.25) and the well-known inequality $\sin x > \frac{2}{\pi}x$ for $0 < x < \frac{\pi}{2}$.

It is clear that $s(\theta)$ is positive on $(0, \pi)$. Observe that

$$\frac{(\sin \theta)^{\mu+1}}{\theta^{\mu-2}} \frac{\partial^2}{\partial \theta \partial \mu} s(\theta) = ((\mu-1) \sin \theta - \mu \theta \cos \theta) \log \frac{\sin \theta}{\theta} - \sin \theta + \theta \cos \theta =: h(\mu, \theta)$$

and that

$$\frac{\partial}{\partial \mu} h(\mu, \theta) = (\sin \theta - \theta \cos \theta) \log \frac{\sin \theta}{\theta} < 0$$

for $\theta \in (0, \pi)$. Since $h(0, \theta) < 0$ and $s'(\theta)|_{\mu=1} = 0$ for all $\theta \in (0, \pi)$, s is increasing on $(0, \pi)$ for all $\mu \in (0, 1)$. \square

In the next lemma we present several technical results that will be needed in the proof of the case $\rho = \frac{1}{5}$ of Conjecture 2.10.

LEMMA 2.13. *Let $\rho \in (0, \frac{1}{2})$ and set $\mu := \mu^*(\rho)$.*

(1) *Suppose $\theta \in (0, b)$ with $b \leq \frac{\pi}{2}$. Then for all $x > 0$*

$$\frac{1}{\sin(\theta)} \int_0^x \frac{\cos(t + \rho\theta - (\rho - \frac{1}{2})\pi)}{t^{1-\mu}} dt \geq \frac{1}{\sin(b)} \int_0^x \frac{\cos(t + \rho b - (\rho - \frac{1}{2})\pi)}{t^{1-\mu}} dt.$$

(2) *Suppose $\theta \in (0, b)$ with $b \leq \frac{\pi}{2}$. Then for all $x > 0$*

$$\frac{1}{\sin(\theta)} \int_0^x \frac{\sin(t + \rho\theta)}{t^{1-\mu}} dt \geq \frac{\cos(\rho b)}{\sin(b)} \int_0^x \frac{\sin(t)}{t^{1-\mu}} dt + \rho \int_0^x \frac{\cos(t)}{t^{1-\mu}} dt. \quad (2.27)$$

(3) *The functions*

$$\theta \mapsto \cos \left[\left(\rho - \frac{\mu}{2} \right) (\theta - \pi) \right]$$

and

$$\theta \mapsto \cos \left[(\rho - \mu)\theta + \pi \left(\frac{\mu + 1}{2} - \rho \right) \right]$$

are positive and increasing on $(0, \frac{\pi}{2})$.

(4) *The functions*

$$\theta \mapsto -\sin \left[\left(\rho - \frac{\mu}{2} \right) \theta + \frac{\pi}{2}(\mu - 1) \right]$$

and

$$\theta \mapsto \sin \left[(\rho - \mu)\theta + \frac{\mu\pi}{2} \right]$$

are positive and decreasing on $(0, \pi)$.

(5) *The functions*

$$\theta \mapsto \frac{\sin(\rho\theta)}{\sin(\theta)} \quad \text{and} \quad \theta \mapsto -\frac{\cos(\rho\theta)}{\sin(\theta)}$$

are increasing in $(0, \frac{\pi}{2})$.

PROOF. We have

$$\begin{aligned} \frac{1}{\sin(\theta)} \int_0^x \frac{\cos(t + \rho\theta - (\rho - \frac{1}{2})\pi)}{t^{1-\mu}} dt &= \\ &= \frac{\sin(\rho\theta)}{\sin(\theta)} \int_0^x \frac{\sin(t - (\rho + \frac{1}{2})\pi)}{t^{1-\mu}} dt - \frac{\cos(\rho\theta)}{\sin(\theta)} \int_0^x \frac{\sin(t - \rho\pi)}{t^{1-\mu}} dt. \end{aligned}$$

Since by Lemma 2.4 the function $\mu^*(\rho)$ is increasing, it follows from Lemma 2.3 that

$$\int_0^{(c+1)\pi} \frac{\sin(t - c\pi)}{t^{1-\mu}} dt \leq 0 \quad (2.28)$$

for $c = \rho$ and $c = \rho + \frac{1}{2}$. It is easy to see that the function $x \mapsto \int_0^x t^{\mu-1} \sin(t - c\pi) dt$ has its largest local maximum in $(0, \infty)$ at the point $(c+1)\pi$ and therefore inequality (2.28) will also hold if we replace the upper integration limit by any positive x . Hence, because of Statement (5), we find that for $\theta \in (0, b)$

$$\begin{aligned} \frac{1}{\sin(\theta)} \int_0^x \frac{\cos(t + \rho\theta - (\rho - \frac{1}{2})\pi)}{t^{1-\mu}} dt &\geq \\ &\geq \frac{\sin(\rho b)}{\sin(b)} \int_0^x \frac{\sin(t - (\rho + \frac{1}{2})\pi)}{t^{1-\mu}} dt - \frac{\cos(\rho b)}{\sin(b)} \int_0^x \frac{\sin(t - \rho\pi)}{t^{1-\mu}} dt \\ &= \frac{1}{\sin(b)} \int_0^x \frac{\cos(t + \rho b - (\rho - \frac{1}{2})\pi)}{t^{1-\mu}} dt. \end{aligned}$$

Statement (1) is thus proven.

For the proof of Statement (2) note that

$$\frac{1}{\sin(\theta)} \int_0^x \frac{\sin(t + \rho\theta)}{t^{1-\mu}} dt = \frac{\cos(\rho\theta)}{\sin(\theta)} \int_0^x \frac{\sin(t)}{t^{1-\mu}} dt + \frac{\sin(\rho\theta)}{\sin(\theta)} \int_0^x \frac{\cos(t)}{t^{1-\mu}} dt.$$

By (2.6) we have $S(x) := \int_0^x \frac{\sin(t)}{t^{1-\mu}} dt \geq 0$ for all $x \geq 0$ and $\rho \in (0, 1)$. Furthermore, since $\mu^*(\rho)$ is increasing, it follows from Lemma 2.3 that

$$C(x) := \int_0^x \frac{\cos(t)}{t^{1-\mu}} dt = - \int_0^x \frac{\sin(t - \frac{\pi}{2})}{t^{1-\mu}} dt \geq 0$$

for all $x > 0$ and $\rho \in (0, \frac{1}{2}]$ (note that $C(x)$ takes its absolute minimum in $x > 0$ at $x = \frac{3\pi}{2}$). Statement (2) thus follows from Statement (5) and the limit relation

$$\frac{\sin(\rho\theta)}{\sin(\theta)} \rightarrow \rho \quad \text{as } \theta \rightarrow 0.$$

For $\theta = 0$ and $\theta = \frac{\pi}{2}$ the expression $(\rho - \frac{\mu}{2})(\theta - \pi)$ is equal to $a := -\pi(\rho - \frac{\mu}{2})$ and $b := -\frac{\pi}{2}(\rho - \frac{\mu}{2})$, respectively. Since, by Lemma 2.6 and (2.5), $\mu < 2\rho$ and $2\rho < 2\mu < \mu + 1$, we have $-\frac{\pi}{2} \leq a < b \leq 0$. Therefore the function $\theta \mapsto \cos[(\rho - \frac{\mu}{2})(\theta - \pi)]$ is positive and increasing on $(0, \frac{\pi}{2})$. Using similar reasoning one can prove the rest of Statement (3) as well as Statement (4).

Since $\rho \in (0, \frac{1}{2})$, both $\cos(\rho\theta)$ and $\sin^{-1}(\theta)$ are decreasing in $(0, \frac{\pi}{2})$. Because of the convexity of the tangent in $(0, \frac{\pi}{2})$ we have $\rho \tan(\theta) > \tan(\rho\theta)$ or, equivalently,

$$\sin^2(\theta) \frac{d}{d\theta} \frac{\sin(\rho\theta)}{\sin(\theta)} = \rho \sin(\theta) \cos(\rho\theta) - \cos(\theta) \sin(\rho\theta) > 0$$

for $\theta \in (0, \frac{\pi}{2})$. The proof of the lemma is now complete. \square

In our next result we will show that Conjecture 2.10 is true for all ρ in a non-empty open subset of $(0, 1)$. Because of Lemmas 2.4 and 2.9, this implies that we can now verify Conjecture 2.1 for all $\rho \in (0, 1)$ by proving that the function $\mu(\rho)$ is analytic.

THEOREM 2.14. *Conjecture 2.10 is true for all ρ in an open neighborhood of $\frac{1}{5}$.*

PROOF. In the proof we write $\mu_0 := \mu^*(\frac{1}{5}) = 0.31\dots < \frac{1}{3}$, $\mu := \mu^*(\rho)$, $\sigma_n(\rho, \theta) := \sigma_n(\rho, \mu^*(\rho), \theta)$, and $\sigma_n(\theta) := \sigma_n(\frac{1}{5}, \theta)$ for $\rho \in (0, 1)$ and $\theta \in (0, \pi]$. Observe that

$$\tau_n(\rho, \theta) := \sigma_n(\rho, \pi - \theta) = \sum_{k=0}^n \frac{(\mu)_k}{k!} \cos \left[(2k + \rho)\theta - \left(\rho - \frac{1}{2} \right) \pi \right] \quad (2.29)$$

and that therefore $\sigma_n(\rho, \theta) > 0$ for a $\theta \in (0, \pi]$ if, and only if, $\tau_n(\rho, \pi - \theta) > 0$. We will split the proof into several subcases.

(1) The case $\theta \in (0, \frac{\pi}{n+1}] \cup [\pi - \frac{\rho\pi}{n+\rho}, \pi]$. Recall the well-known identity

$$e^{ic} \sum_{k=0}^n e^{ik\theta} = e^{i(c+n\theta/2)} \frac{\sin \frac{n+1}{2}\theta}{\sin \frac{\theta}{2}}, \quad n \in \mathbb{N},$$

which holds for all $\theta \in \mathbb{R}$, for which $\sin \frac{\theta}{2}$ does not vanish, and every $c \in \mathbb{R}$ (which might even depend on θ).

Because of this formula and the fact that the sequence $\{\frac{(\mu)_k}{k!}\}_{k \in \mathbb{N}_0}$ is decreasing, a summation by parts shows that for all $\rho \in (0, \frac{1}{2})$ we have $\sigma_n(\rho, \theta) > 0$ for $\theta \in (0, \frac{\pi}{n+1}]$, and $\tau_n(\rho, \theta) > 0$ for $\theta \in [0, \frac{\rho\pi}{n+\rho}]$.

(2) The case $\theta \in [\frac{\pi}{n+1}, \frac{\pi}{3}]$, $n \geq 3$. We apply Lemma 2.12 with the parameters $f(\theta) = \sin \theta$ and $c(\theta) = \rho\theta$ on the interval $I := [a_n, b]$, where $a_n = \frac{\pi}{n+1}$ and $b = \frac{\pi}{3}$.

It follows from Lemma 2.13 (2) that with $S(x) := \int_0^x t^{\mu-1} \sin(t) dt$ and $C(x) := \int_0^x t^{\mu-1} \cos(t) dt$ we have

$$\kappa_n(\theta) \geq \frac{\cos(\rho b)}{\sin(b)} S((2n+1)\theta) + \rho C((2n+1)\theta)$$

for $\rho \in (0, \frac{1}{2})$, $\theta \in I$ and $n \geq 3$. At $x = \frac{7\pi}{4}$ the function $S(x)$ is decreasing and thus it is clear that $S(x) \geq S(2\pi)$ for all $x \geq \frac{7\pi}{4}$. The function $C(x)$ is increasing at $x = \frac{7\pi}{4}$, has local minima in $x \geq \frac{7\pi}{4}$ exactly at the points $x_j := (2j + \frac{3}{2})\pi$, $j \in \mathbb{N}$, and satisfies $C(x_1) \leq C(x_j)$ for all $j \in \mathbb{N}$. Therefore, since $C(\frac{7\pi}{4}) < C(x_1)$ when $\mu = \mu_0$, we find that

$$\kappa_n(\theta) \geq \frac{\cos(\rho b)}{\sin(b)} S(2\pi) + \rho C\left(\frac{7\pi}{4}\right) =: R_1(\rho)$$

for all $\theta \in I$, $n \geq 3$, and ρ in an open neighborhood of $\frac{1}{5}$.

Because of Lemma 2.13 (4), for $f(\theta)$ and $c(\theta)$ as above, the functions $-q(\theta)$ and $r(\theta)$ are positive and decreasing on I for all $\rho \in (0, \frac{1}{2})$. It thus follows from Lemma 2.13 (5) that for $\theta \in I$

$$\Gamma(\mu) \left(2q(\theta) \frac{\sin \frac{\mu\theta}{2}}{\sin \theta} - r(\theta)s(\theta) \right) \geq \Gamma(\mu) \left(2q(0) \frac{\sin \frac{\mu b}{2}}{\sin b} - r(0)s(b) \right) =: R_2(\rho).$$

Furthermore, for a_n and b as defined above and $n \geq 3$, the expression $-A_n - B_n - C_n$ that appears in Lemma 2.12 is larger than

$$R_3(\rho) := -\frac{b}{\sin b} \frac{1-\mu}{12 \left(\frac{3\pi}{2}\right)^{1-\mu}} - \left(\frac{b}{\sin b}\right)^2 \frac{1-\mu}{9 \left(\frac{3\pi}{2}\right)^{1-\mu}} - \frac{1}{9(2\pi)^{1-\mu}}.$$

Lemma 2.12 thus shows that for ρ in an open neighborhood of $\frac{1}{5}$, $\theta \in I$ and $n \geq 3$

$$2^\mu \theta^{\mu-1} \Gamma(\mu) \sigma_n(\rho, \theta) \geq R(\rho) := R_1(\rho) + R_2(\rho) + R_3(\rho).$$

$\mu = \mu^*(\rho)$ depends continuously on ρ and therefore the function $R(\rho)$ is continuous in $(0, 1)$. Since $R(\frac{1}{5}) = 0.432 \dots > 0$, we conclude that $\sigma_n(\rho, \theta) > 0$ for all $\theta \in I$, $n \geq 3$, and ρ in an open neighborhood of $\frac{1}{5}$.

(3) The case $\theta \in [\frac{\pi}{3}, \frac{2\pi}{3}]$, $n \geq 3$. For $\theta \in (0, \pi)$ we have

$$\sigma_n(\rho, \theta) \rightarrow \frac{\sin[(\rho - \mu)\theta + \frac{\mu\pi}{2}]}{(2 \sin \theta)^\mu}, \quad n \rightarrow \infty$$

and for all $\rho \in (0, 1)$ the sequence $\{\frac{(\mu)_n}{n!}\}_{n \in \mathbb{N}_0}$ is decreasing. Applying inequality (1.26) and Lemma 2.13 (4), we thus find that for $n \geq 3$, $\rho \in (0, \frac{1}{2})$ and $\theta \in [\frac{\pi}{3}, \frac{2\pi}{3}]$

$$\begin{aligned} \sigma_n(\rho, \theta) &\geq \frac{\sin[(\rho - \mu)\theta + \frac{\mu\pi}{2}]}{(2 \sin \theta)^\mu} - \frac{(\mu)_{n+1}}{(n+1)! \sin \theta} \\ &\geq 2^{-\mu} \sin \left[\frac{\pi}{6} (4\rho - \mu) \right] - \frac{(\mu)_4}{24 \sin \frac{\pi}{3}} =: R(\rho). \end{aligned}$$

Since $R(\frac{1}{5}) = 0.049 \dots$ and since $R(\rho)$ is a continuous function, we obtain $\sigma_n(\rho, \theta) > 0$ for all $\theta \in [\frac{\pi}{3}, \frac{2\pi}{3}]$, $n \geq 3$, and ρ in an open neighborhood of $\frac{1}{5}$.

(4) The cases $\theta \in [\frac{2\pi}{3}, \pi - \frac{\pi}{2n+2}]$, $n \geq 3$, and $\theta \in [\pi - \frac{\pi}{2n+2}, \pi - \frac{\rho\pi}{n+\rho}]$, $n \geq 5$. We make use of (2.29) and show that, for all ρ in an open neighborhood of $\frac{1}{5}$, $\tau_n(\rho, \theta) > 0$ when $\theta \in [\frac{\rho\pi}{n+\rho}, \frac{\pi}{2n+2}]$ and $n \geq 5$ or $\theta \in [\frac{\pi}{2n+2}, \frac{\pi}{3}]$ and $n \geq 3$. To this end, we apply

Lemma 2.12 with the parameters $f(\theta) = \cos(\theta)$ and $c(\theta) = \rho\theta - (\rho - \frac{1}{2})\pi$ separately on the three intervals $I_k := [a_n^{(k)}, b_n^{(k)}]$, where

$$\begin{aligned} a_n^{(1)} &:= \frac{\rho\pi}{n + \rho}, & b_n^{(1)} &:= \frac{\pi}{2n + 2}, \\ a_n^{(2)} &:= \frac{\pi}{2n + 2}, & b_n^{(2)} &:= \frac{\pi}{n + 2}, \\ a_n^{(3)} &:= \frac{\pi}{n + 2}, & b_n^{(3)} &:= \frac{\pi}{3}. \end{aligned}$$

In the following, for every estimate concerning θ in the interval I_1 we make the assumption $n \geq 5$, while for estimates concerning $\theta \in I_2 \cup I_3$ we assume $n \geq 3$. We set $\chi(1) := 5$ and $\chi(2) := \chi(3) := 3$.

It follows from Lemma 2.13 (1) that for $0 < \theta \leq b \leq \frac{\pi}{2}$ and $\rho \in (0, \frac{1}{2})$ we have $\kappa_n(\theta) \geq J(b, (2n + 1)\theta)$, where

$$J(b, x) := \frac{1}{\sin b} \int_0^x \frac{\cos(t + \rho b - (\rho - \frac{1}{2})\pi)}{t^{1-\mu}} dt.$$

Hence, for $\theta \in I_1$, $\theta \in I_2$, and $\theta \in I_3$ we have

$$\begin{aligned} \kappa_n(\theta) &\geq J_1((2n + 1)\theta) := J\left(\frac{\pi}{12}, (2n + 1)\theta\right), \\ \kappa_n(\theta) &\geq J_2((2n + 1)\theta) := J\left(\frac{\pi}{5}, (2n + 1)\theta\right), \\ \kappa_n(\theta) &\geq J_3((2n + 1)\theta) := J\left(\frac{\pi}{3}, (2n + 1)\theta\right), \end{aligned}$$

respectively. For all $\rho \in (0, 1)$ there is exactly one $x_\rho \in [0, \pi]$ such that $J_1'(x) > 0$ for $x \in [0, x_\rho]$ and $J_1'(x) < 0$ for $x \in (x_\rho, \pi]$. Hence, since $J_1(\pi) < 0$ when $\rho = \frac{1}{5}$, we have $J_1(x) \geq J_1(\pi)$ for all $x \in [0, \pi]$ and all ρ in a neighborhood of $\frac{1}{5}$. Similar reasoning shows that $J_2(x) \geq J_2((1 + \frac{4\rho}{5})\pi)$ and $J_3(x) \geq J_3(\frac{7\pi}{5})$ for all ρ in a neighborhood of $\frac{1}{5}$ and, respectively, all $x \geq 0$ and $x \geq \frac{7\pi}{5}$. Minimizing $J_1(x)$ over $x \in [0, \pi]$, $J_2(x)$ over $x \geq 0$, and $J_3(x)$ over $x \geq \frac{7\pi}{5}$, we thus find that

$$\begin{aligned} \kappa_n(\theta) &\geq R_1^{(1)}(\rho) := J_1(\pi), & \theta &\in I_1, \\ \kappa_n(\theta) &\geq R_1^{(2)}(\rho) := J_2\left(\left(1 + \frac{4\rho}{5}\right)\pi\right), & \theta &\in I_2, \\ \kappa_n(\theta) &\geq R_1^{(3)}(\rho) := J_3\left(\frac{7\pi}{5}\right), & \theta &\in I_3 \end{aligned}$$

for all ρ in a neighborhood of $\frac{1}{5}$.

It follows from Lemma 2.12 and Statements (3) and (5) of Lemma 2.13 that for $\rho \in (0, \frac{1}{2})$ and $\theta \in I_k$, $k \in \{1, 2, 3\}$, we have

$$\Gamma(\mu) \left(2q(\theta) \frac{\sin \frac{\mu\theta}{2}}{\sin \theta} - r(\theta)s(\theta) \right) \geq \Gamma(\mu) \left(\mu q(0) - r(b_{\chi(k)}^{(k)})s(b_{\chi(k)}^{(k)}) \right) =: R_2^{(k)}(\rho).$$

Furthermore, it is easy to see that for $k \in \{1, 2, 3\}$ the sequences $\{-b_n^{(k)}\}_{n \in \mathbb{N}_0}$, $\{na_n^{(k)}\}_{n \in \mathbb{N}_0}$, and $\{(n+1)a_n^{(3)}\}_{n \in \mathbb{N}_0}$ are increasing. We also have $(n+1)a_n^{(1)} \geq \rho\pi$ and $(n+1)a_n^{(2)} = \frac{\pi}{2}$

for $n \in \mathbb{N}$. For $\rho \in (0, 1)$ and $k \in \{1, 2, 3\}$ we set

$$R_3^{(k)}(\rho) := \frac{b_{\chi(k)}^{(k)}}{\sin b_{\chi(k)}^{(k)}} \frac{\mu - 1}{4\chi(k) \left(2\chi(k)a_{\chi(k)}^{(k)}\right)^{1-\mu}} + \left(\frac{b_{\chi(k)}^{(k)}}{\sin b_{\chi(k)}^{(k)}}\right)^2 \frac{\mu - 1}{3\chi(k) \left(2\chi(k)a_{\chi(k)}^{(k)}\right)^{1-\mu}} - Q^{(k)},$$

where

$$Q^{(1)} := \frac{2\pi}{9(2\rho\pi)^{2-\mu}}, \quad Q^{(2)} := \frac{2}{9\pi^{1-\mu}}, \quad Q^{(3)} := \frac{2\pi}{9(8a_3^{(3)})^{2-\mu}}.$$

It now follows from Lemma 2.12 that for all $\theta \in I_k$ and all ρ in an open neighborhood of $\frac{1}{5}$

$$2^\mu \theta^{\mu-1} \Gamma(\mu) \tau_n(\rho, \theta) \geq R_1^{(k)}(\rho) + R_2^{(k)}(\rho) + R_3^{(k)}(\rho) =: R^{(k)}(\rho), \quad k \in \{1, 2, 3\}.$$

The functions $R^{(k)}(\rho)$ are continuous and we have $R^{(1)}(\frac{1}{5}) = 0.015\dots$, $R^{(2)}(\frac{1}{5}) = 0.040\dots$, and $R^{(3)}(\frac{1}{5}) = 0.111\dots$. The proof of this subcase is complete.

(5) The cases $n = 1, \dots, 4$. We have already proven that $\sigma_n(\rho, \theta) > 0$ for all $\theta \in (0, \pi]$, $n \geq 5$, and ρ in an open neighborhood of $\frac{1}{5}$. Because of continuity it will thus be enough to show that $\sigma_n(\theta) = \sigma_n(\frac{1}{5}, \theta) > 0$ for $n = 1, \dots, 4$.

To this end, observe that

$$\sin[(2n + 2 + \rho)\theta] < 0, \quad \text{with } \theta \in (0, \pi], n \in \mathbb{N}, \rho \in (0, 1),$$

if, and only if,

$$\theta \in \left[\frac{(2k + 1)\pi}{2n + 2 + \rho}, \frac{(2k + 2)\pi}{2n + 2 + \rho} \right] =: I_{n,k}, \quad k = 0, \dots, n.$$

Since $[\pi - \frac{\pi}{2n+2}, \pi - \frac{\rho\pi}{n+\rho}]$ is contained in $I_{n,n}$ and since

$$\sigma_n(\theta) = \sigma_{n+1}(\theta) - \frac{(\mu_0)_{n+1}}{(n+1)!} \sin[(2n + 2 + \rho)\theta],$$

we see that the cases $n = 3, 4$ follow from the subcases (1)–(4).

Because of $\mu_0 < \frac{1}{3}$ the sequence

$$\left\{ \frac{(\mu_0)_k}{\left(\frac{1}{3}\right)_k} \right\}_{k \in \mathbb{N}_0}$$

is decreasing. Summation by parts therefore shows that it will suffice to verify that

$$w_n(\theta) := \sum_{k=0}^n \frac{\left(\frac{1}{3}\right)_k}{k!} \sin \left[\left(2k + \frac{1}{5}\right) \theta \right] > 0$$

in $(0, \theta]$ for $n = 1, 2$ in order to prove the remaining cases of the theorem. It is easy to check that $w_n(\theta) = \sin \frac{\theta}{5} p_n(\cos^2 \frac{\theta}{5})$, $n = 1, 2$, where

$$\begin{aligned} p_1(x) &:= \frac{2}{3} (1 + 30x - 280x^2 + 896x^3 - 1152x^4 + 512x^5), \\ p_2(x) &:= \frac{4}{9} (2 - 65x + 3540x^2 - 53568x^3 + 382656x^4 - 1536768x^5 + 3727360x^6 \\ &\quad - 5570560x^7 + 5013504x^8 - 2490368x^9 + 524288x^{10}). \end{aligned}$$

Using the method of Sturm sequences [RS02, p. 336], we see that $p_n(x)$ does not vanish in $(0, 1)$ when $n = 1, 2$. The proof of the theorem is complete. \square

Some Completely Monotonic Functions

As we have seen in the previous chapter, the monotonicity of the functions

$$\xi(x) = x - \frac{\Gamma(x + \mu)}{\Gamma(x + 1)} x^{2-\mu}$$

in $(0, \infty)$ for $\mu \in [\frac{1}{3}, 1)$ plays a crucial role in Koumandos' method for proving the positivity of trigonometric sums with coefficient sequences of the form $\{\frac{(\mu)_k}{k!}\}_{k \in \mathbb{N}_0}$. However, it is certainly not trivial to show that $\xi'(x) > 0$ for $x > 0$. In fact, over the years, inequalities involving the gamma or psi function have attracted considerable attention and led to quite sophisticated methods. An extensive bibliography concerning such inequalities can be found in [Kou08].

In [Kou08] and [KL09a] Koumandos tackled the problem regarding the monotonicity of the functions $\xi(x)$ by showing that $\xi'(x)$ is completely monotonic for $\mu \in [\frac{1}{3}, 1)$. A function $f : (0, \infty) \rightarrow \mathbb{R}$ is called *completely monotonic* if it has derivatives of all orders and satisfies

$$(-1)^n f^{(n)}(x) \geq 0, \text{ for all } x > 0 \text{ and } n \geq 0. \quad (3.1)$$

In particular, each completely monotonic function is positive in $(0, \infty)$.

In [Dub39] (see also [vH96] for a simpler proof) J. Dubourdieu proved that if a non-constant function f is completely monotonic, then strict inequality holds in (3.1). A necessary and sufficient condition for complete monotonicity is given by Bernstein's theorem (see [Wid41, p. 161]), which states that f is completely monotonic on $(0, \infty)$ if, and only if

$$f(x) = \int_0^\infty e^{-xt} dm(t),$$

where m is a nonnegative measure on $[0, \infty)$ such that the integral converges for all $x > 0$.

In [KP09] Koumandos and Pedersen introduced the concept of complete monotonicity of order n : a function f defined on $(0, \infty)$ is called *completely monotonic of order* $n \in \mathbb{N}_0$ if $x^n f(x)$ is completely monotonic on $(0, \infty)$. For instance, completely monotonic functions of order 0 are the classical completely monotonic functions, while completely monotonic functions of order 1 are the strongly completely monotonic functions that have been introduced in [TWW89]. It is easy to see that a function f is completely monotonic if $xf(x)$ is completely monotonic and therefore a function that is completely monotonic of order n is completely monotonic of order $m = 0, 1, \dots, n - 1$.

In [KP09, Thm. 1.3] (see also [TWW89, Thm. 1] and [Kou08, Lem. 2]) Koumandos and Pedersen showed that there is an extension of Bernstein's theorem to completely monotonic functions of order n : a function f is completely monotonic of order $n \geq 1$ on $(0, \infty)$ if, and only if,

$$f(x) = \int_0^\infty e^{-xt} p(t) dt,$$

where the integral converges for all $x > 0$ and where p is $n - 1$ times differentiable on $[0, \infty)$ with $p^{(n-1)}(t) = m([0, t])$ for some Radon measure m and $p^{(k)}(0) = 0$ for $0 \leq k \leq n - 2$.

In the following we will briefly explain how this result is used in [Kou08, Thm. 1] in order to prove the complete monotonicity of a family of functions that includes all functions $\xi'(x)$ with $\mu \in [\frac{1}{2}, 1)$:

Define

$$L_{s,t}(x) := x - \frac{\Gamma(x+t)}{\Gamma(x+s)} x^{s-t+1}, \quad x > 0, s, t \in \mathbb{R}$$

and observe that we have $L_{1,\mu}(x) = \xi(x)$. Then for all $(s, t) \in \mathbb{R}^2$ one has

$$\lim_{x \rightarrow \infty} L'_{s,t}(x) = 0$$

and therefore, in order to prove the complete monotonicity of $L'_{s,t}(x)$, it will be enough to show that $-L''_{s,t}(x)$ is completely monotonic. Now,

$$\Phi(x) := -\frac{\Gamma(x+s)}{\Gamma(x+t)} x^{t-s-1} L''_{s,t}(x)$$

can be written in the form

$$\Phi(x) = \int_0^\infty e^{-xu} F(u) du,$$

where

$$F(u) := \int_0^u \sigma(u-v)\sigma(v)dv - u\sigma(u)$$

with $\sigma(u) := \phi_{s,t}(0) - \phi_{s,t}(u) + 1$, $\phi_{s,t}(0) := s - t$, and

$$\phi_{s,t}(u) := \frac{e^{(1-t)u} - e^{(1-s)u}}{e^u - 1}, \quad u > 0.$$

It then follows that

$$F'(u) = \int_0^u \sigma'(u-v)\sigma(v)dv - u\sigma'(u)$$

and

$$F''(u) = u\phi''_{s,t}(u) + \int_0^u \phi'_{s,t}(u-v)\phi'_{s,t}(v)dv.$$

The latter relation shows that for every pair (s, t) in the set T of points in \mathbb{R}^2 for which $\phi_{s,t}(u)$ is monotonic and convex in $(0, \infty)$ we have $F''(u) \geq 0$ and, since $F'(0) = F(0) = 0$, also $F(u), F'(u) \geq 0$ for all $u \in (0, \infty)$. Therefore, by Koumandos and Pedersen's extension of Bernstein's theorem [KP09, Thm. 1.3], for all $(s, t) \in T$ the function $\Phi(x)$ is completely monotonic of order 2 (i.e. $x^2\Phi(x)$ is completely monotonic). Furthermore, since for $s - t < 1$ the functions $\Gamma(x+t)/\Gamma(x+s)$ and x^{s-t-1} are completely monotonic (cf. [Kou08, p. 2268]), it follows that, for all $(s, t) \in T$ with $s - t < 1$, the function

$$-L''_{s,t}(x) = x^{s-t-1} \frac{\Gamma(x+t)}{\Gamma(x+s)} x^2 \Phi(x)$$

is completely monotonic in $(0, \infty)$ as a product of completely monotonic functions. This, together with three other results from [Kou08] that depend on the monotonicity and concavity properties of the function $\phi_{s,t}(u)$, are put together in the following theorem. S denotes the set of points $(s, t) \in \mathbb{R}^2$ for which $\phi_{s,t}(u)$ is convex in $(0, \infty)$.

THEOREM 3.1. (1) For $(s, t) \in T \cap \{(s, t) : s - t < 1\}$ the function $L'_{s,t}(x)$ is completely monotonic on $(0, \infty)$ and for $(s, t) \in T$ the function $\Phi(x)$ is completely monotonic of order 2 on $(0, \infty)$. In particular, for $(s, t) \in T \cap \{(s, t) : s - t < 1\}$, the function $L_{s,t}(x)$ is strictly increasing and concave on $(0, \infty)$ and the inequality

$$0 < x - \frac{\Gamma(x+t)}{\Gamma(x+s)}x^{s-t+1} < \frac{1}{2}(s-t)(s+t-1) \quad (3.2)$$

holds for all $x > 0$ (cf. [Kou08, Thm. 1]).

(2) For $(s, t) \in T \cap \{(s, t) : s - t < 1\}$ the inequality

$$\psi(x+t) - \psi(x+s) + \frac{s-t+1}{x} < \frac{\Gamma(x+s)}{\Gamma(x+t)}x^{t-s-1}$$

holds for all $x > 0$ and the function

$$\psi(x+s) - \psi(x+t) - \frac{s-t}{x} + \frac{(s-t)(s+t-1)}{2x^2}$$

is completely monotonic in $(0, \infty)$ for all $(s, t) \in S$ (cf. [Kou08, Cor. 1]).

(3) For $m, n \in \mathbb{N}$ with $m > n$ let

$$U_{n,m}(x) := \sum_{k=n}^m \frac{\binom{t}{k}}{\binom{s}{k}} e^{ikx}, \quad V_{n,m}(x) := \frac{\Gamma(s)}{\Gamma(t)} \sum_{k=n}^m \frac{1}{k^{s-t}} e^{ikx}.$$

If

$$(s, t) \in T \cap \{(s, t) : 1 \leq s, 0 < s - t < 1\},$$

then for $\frac{\pi}{n} \leq x < \pi$, $n > 1$, the estimate

$$|U_{n,m}(x) - V_{n,m}(x)| < \frac{1}{n^{s-t}} \frac{\Gamma(s)}{\Gamma(t)} \frac{(s-t)(s+t-1)}{2}$$

holds (cf. [Kou08, Prop. 1]).

(4) Let

$$\Lambda(x) := x \log \left(\frac{\Gamma(x+t)}{\Gamma(x+s)} x^{s-t} \right)$$

and

$$K(x) := \psi'(x+t) - \psi'(x+s) + \frac{2}{x}[\psi(x+t) - \psi(x+s)] + \frac{s-t}{x^2}.$$

If $(s, t) \in S$, then the function $K(x) = \frac{1}{x}\Lambda''(x)$ is completely monotonic of order 2 on $(0, \infty)$ and the function $-\Lambda'(x)$ is completely monotonic on $(0, \infty)$. In particular, the function $\Lambda(x)$ is strictly decreasing and convex on $(0, \infty)$, so that

$$-\frac{(s-t)(s+t-1)}{2} < x \log \left(\frac{\Gamma(x+t)}{\Gamma(x+s)} x^{s-t} \right) < 0$$

for all $x > 0$ (cf. [Kou08, Prop. 2]).

These results prompt us to look for the sets \mathfrak{M} and \mathfrak{C} of $(\alpha, \beta) \in \mathbb{R}^2$ for which, respectively, the functions $f'_{\alpha,\beta}(x)$ and $f''_{\alpha,\beta}(x)$ are of constant sign in $(0, \infty)$. Here, $f_{\alpha,\beta}(x) := \phi_{1-\beta, 1-\alpha}(x)$, such that

$$f_{\alpha,\beta}(x) = \frac{e^{\alpha x} - e^{\beta x}}{e^x - 1} \quad \text{for } x \in \mathbb{R} \setminus \{0\} \quad \text{and} \quad f_{\alpha,\beta}(0) = \alpha - \beta.$$

We also set $f_{\alpha}(x) := f_{\alpha,0}(x)$ for $x \in \mathbb{R}$. The set \mathfrak{M} was completely determined in [GQ09] and a subset of \mathfrak{C} was found in [Kou08]. As the main result of this chapter

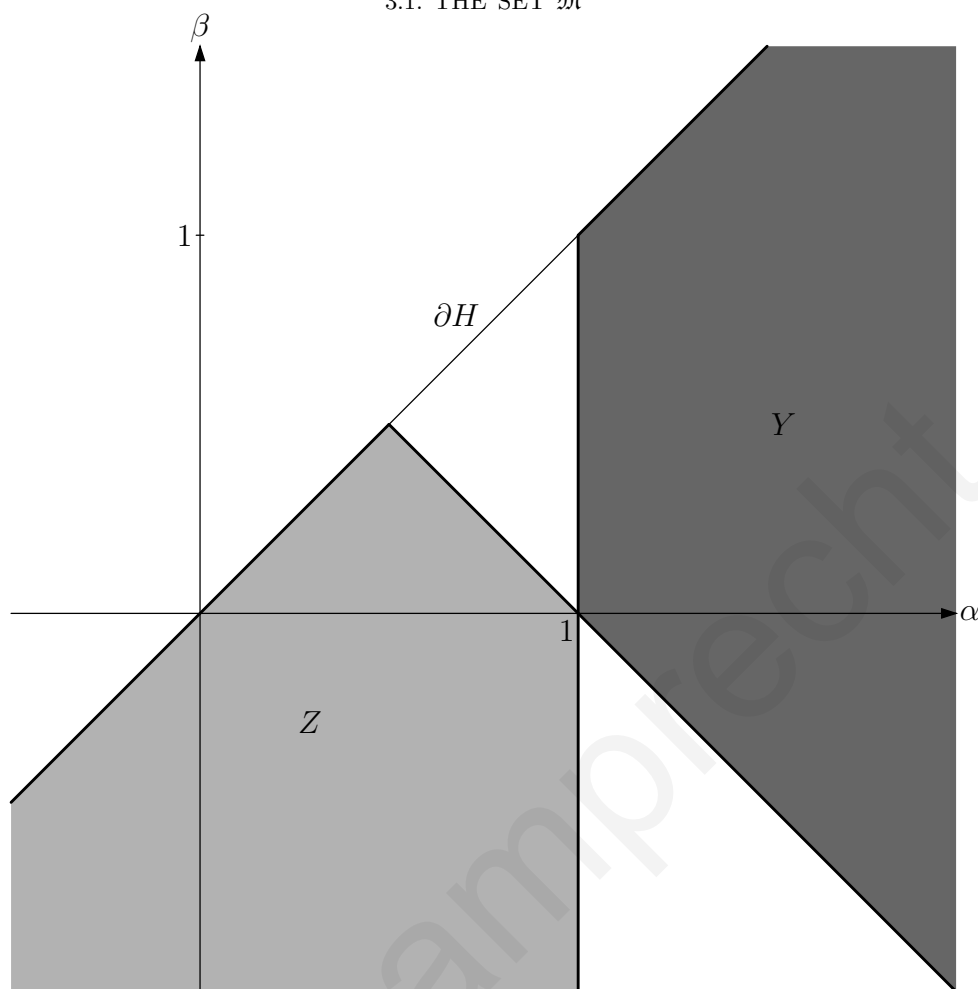
FIGURE 3.1. The sets Y and Z .

we will give a complete description of the set \mathfrak{C} . We will also present a new way of determining \mathfrak{M} and give a new proof of a result which concerns the second and third derivatives of the functions $f_\alpha(x)$ and which can be used in order to prove the complete monotonicity of the functions $\xi(x)$ when $\mu \in [\frac{1}{3}, \frac{1}{2})$.

3.1. The Set \mathfrak{M}

In this section the set \mathfrak{M} of points $(\alpha, \beta) \in \mathbb{R}^2$ for which the function $f_{\alpha, \beta}(x)$ is monotonic in $(0, \infty)$ will be determined in a short and comprehensible way.

The question for an exact description of \mathfrak{M} had attracted considerable attention even before Koumandos' results from [Kou08] were known. Feng Qi tried to tackle this problem in several papers. In [GQ09] he and Bai-Ni Guo were finally able to determine \mathfrak{M} correctly. Their proof, however, is extremely long and technical and therefore almost incomprehensible. In the following we will show how \mathfrak{M} can be determined in a very short and comprehensible way. In [GQ09] several consequences of the monotonicity of the functions $f_{\alpha, \beta}(x)$ are described.

For the rest of this chapter, let H denote the half-plane $\{(\alpha, \beta) : \beta \leq \alpha\}$ and for any set $M \subset \mathbb{R}^2$ let M^* be its reflection with respect to the straight line ∂H .

THEOREM 3.2. *Let (cf. Figure 3.1)*

$$Y := H \cap \{(\alpha, \beta) \in \mathbb{R}^2 : \alpha \geq 1\} \cap \{(\alpha, \beta) \in \mathbb{R}^2 : \beta \geq 1 - \alpha\}$$

and

$$Z := H \cap \{(\alpha, \beta) \in \mathbb{R}^2 : \alpha \leq 1\} \cap \{(\alpha, \beta) \in \mathbb{R}^2 : \beta \leq 1 - \alpha\}.$$

Then $f_{\alpha,\beta}(x)$ is increasing in $(0, \infty)$ if, and only if, $(\alpha, \beta) \in Y \cup Z^*$ and decreasing in $(0, \infty)$ if, and only if, $(\alpha, \beta) \in Y^* \cup Z$.

Note that $f_{\alpha,\beta}(x) = -f_{\beta,\alpha}(x)$ and that it will therefore suffice to examine the monotonicity of $f_{\alpha,\beta}(x)$ in $(0, \infty)$ for (α, β) in the interior of H in order to verify the theorem. Further, since

$$f'_{\alpha,\beta}(x) = \frac{h_{\alpha,\beta}(e^x)}{(e^x - 1)^2},$$

with

$$h_{\alpha,\beta}(t) := (\alpha - 1)t^{\alpha+1} - \alpha t^\alpha - ((\beta - 1)t^{\beta+1} - \beta t^\beta),$$

the monotonicity of $f_{\alpha,\beta}(x)$ in $(0, \infty)$ is completely determined by the sign of $h_{\alpha,\beta}(t)$ in $(1, \infty)$. The following two lemmas thus give a proof of Theorem 3.2.

LEMMA 3.3. *If (α, β) lies in the interior of $H \setminus (Y \cup Z)$, then $h_{\alpha,\beta}(t)$ changes sign in $(1, \infty)$.*

PROOF. For all $(\alpha, \beta) \in \mathbb{R}^2$ we have $h_{\alpha,\beta}(1) = h'_{\alpha,\beta}(1) = 0$ and $h''_{\alpha,\beta}(1) = (\alpha - \beta)(\alpha + \beta - 1)$. For (α, β) in the interior of H the function $h_{\alpha,\beta}(t)$ is thus positive in a neighborhood of 1 if $\beta > 1 - \alpha$ and negative if $\beta < 1 - \alpha$.

On the other hand, we have

$$\lim_{t \rightarrow \infty} t^{-\alpha-1} h_{\alpha,\beta}(t) = \alpha - 1$$

and $h_{\alpha,\beta}(t)$ is therefore positive for large $t > 1$ if $\alpha > 1$ and negative if $\alpha < 1$. The lemma follows. \square

LEMMA 3.4. *Let $(\alpha, \beta) \neq (1, 0)$. If $(\alpha, \beta) \in Y \setminus \partial H$, then $h_{\alpha,\beta}(t)$ is positive in $(1, \infty)$ and if $(\alpha, \beta) \in Z \setminus \partial H$, then $h_{\alpha,\beta}(t)$ is negative in $(1, \infty)$.*

PROOF. For all (α, β) in the interior of H we have

$$h_{\alpha,\beta}(1) = (t^{-\beta} h_{\alpha,\beta}(t))' \Big|_{t=1} = 0$$

and

$$k_{\alpha,\beta}(t) := \frac{t^{2-\alpha+\beta}}{\alpha - \beta} (t^{-\beta} h_{\alpha,\beta}(t))'' = (\alpha - 1)(\alpha - \beta + 1)t - \alpha(\alpha - \beta - 1).$$

Hence, if for a point (α, β) in the interior of H the function $k_{\alpha,\beta}(t)$ is of constant sign in $(1, \infty)$, then $h_{\alpha,\beta}(t)$ will be of the same sign in $(1, \infty)$. Since $k_{1,\beta}(t) = \beta$ for all $t \in \mathbb{R}$, we thus find that $h_{1,\beta}(t)$ is positive in $(0, \infty)$ if $\beta > 0$ and negative if $\beta < 0$.

Now, suppose that $\alpha \neq 1$. Obviously $k_{\alpha,\beta}(t)$ is of constant sign in $(1, \infty)$ if its only zero

$$t^* := \frac{\alpha(\alpha - \beta - 1)}{(\alpha - 1)(\alpha - \beta + 1)}$$

is ≤ 1 . For $\alpha > 1$ the relation $t^* \leq 1$ is equivalent to $1 - \alpha \leq \beta$, while for $\alpha < 1$ it is equivalent to $\beta \leq 1 - \alpha$. Thus, for (α, β) in the interior of Y or Z or on the line $\{(\alpha, 1 - \alpha) : \alpha \in (\frac{1}{2}, \infty)\}$ the sign of $k_{\alpha,\beta}(t)$ is constant in $(1, \infty)$. The assertion follows from the fact that $k_{\alpha,\beta}(1) = \alpha + \beta - 1$ and a continuity argument. \square

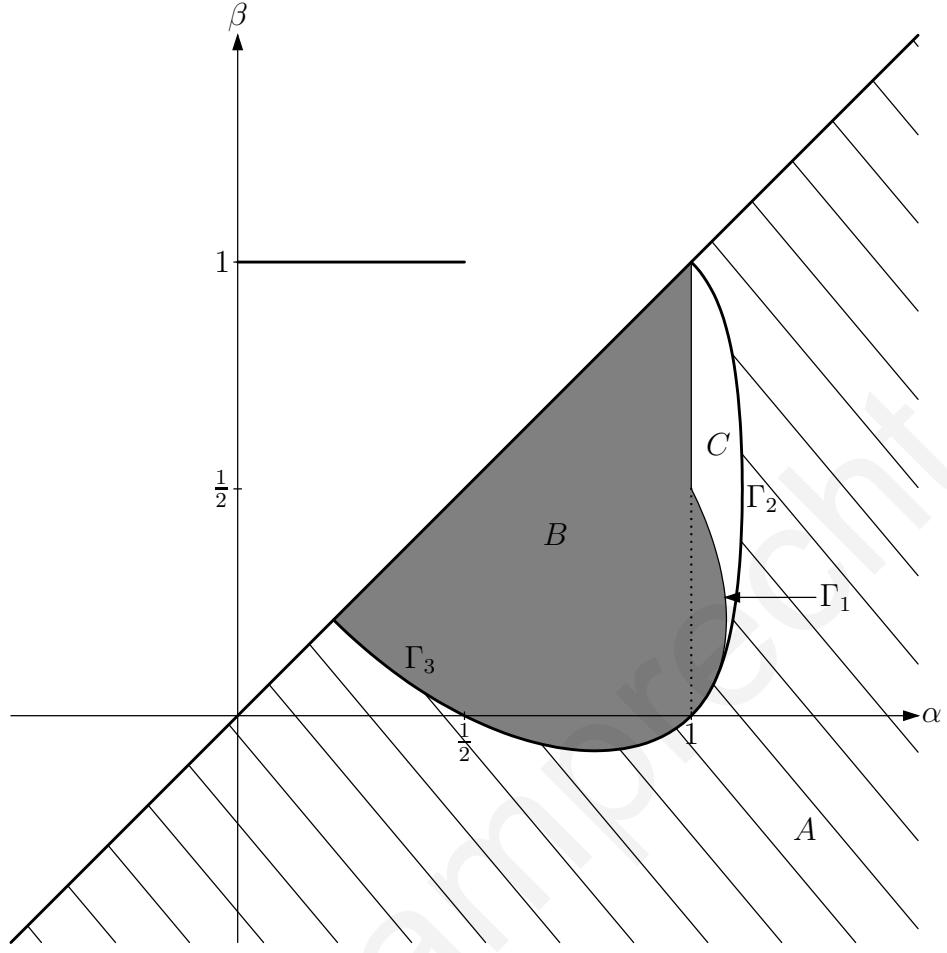

FIGURE 3.2. The sets A , B and C . The bold curves are ∂A . Note that $\Gamma_1 \cap \Gamma_2 \cap \Gamma_3 = (1, 0)$ and that the dotted line $\{(1, \beta) : 0 < \beta \leq \frac{1}{2}\}$ belongs to neither A , B nor C , but to A^* .

3.2. The Set \mathfrak{C}

In this section we will give a complete description of the set \mathfrak{C} of points $(\alpha, \beta) \in \mathbb{R}^2$ for which the function $f''_{\alpha, \beta}(x)$ is of constant sign in $(0, \infty)$.

The four results that are presented in Theorem 3.1 led to a closer examination of the set \mathfrak{C} and subsequently a large subset of \mathfrak{C} was found in [Kou08]. In the following we will show how \mathfrak{C} was completely determined in [KL09b].

In order to state our results, we first need to make the following definitions: For $\alpha, \beta \in \mathbb{R}$ set

$$\begin{aligned} \varepsilon_1(\alpha, \beta) &:= 2\alpha\beta + 2\alpha^2 - 3\alpha + 2\beta^2 - 3\beta + 1, \\ \varepsilon_2(\alpha, \beta) &:= 4\alpha^2\beta^2 - 4\alpha^2\beta - 4\alpha\beta^2 + 4\alpha\beta - \alpha^2 + \alpha - \beta^2 + \beta, \\ \varepsilon_3(\alpha, \beta) &:= \left(\alpha - \frac{1}{2}\right)^2 + \left(\beta - \frac{1}{2}\right)^2 - \frac{1}{2}, \end{aligned}$$

and

$$\begin{aligned} \Gamma_1 &:= \{(\alpha, \beta) : 0 \leq \beta \leq 1 < \alpha\} \cap \{(\alpha, \beta) : \varepsilon_1(\alpha, \beta) = 0\}, \\ \Gamma_2 &:= \{(\alpha, \beta) : 0 \leq \beta \leq 1 \leq \alpha\} \cap \{(\alpha, \beta) : \varepsilon_2(\alpha, \beta) = 0\}, \\ \Gamma_3 &:= \left\{(\alpha, \beta) : \beta \leq \frac{1}{2} - \left|\alpha - \frac{1}{2}\right|\right\} \cap \{(\alpha, \beta) : \varepsilon_1(\alpha, \beta) = 0\}, \end{aligned}$$

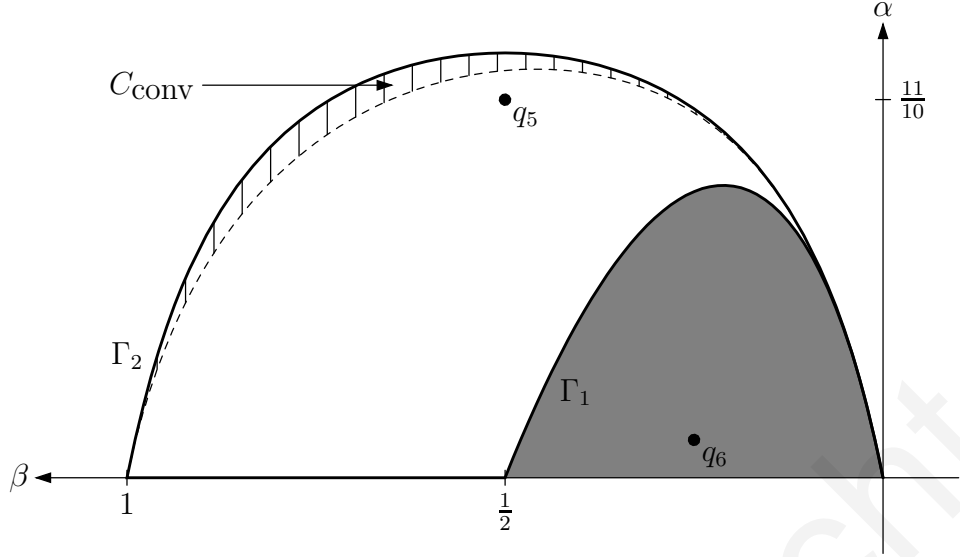

FIGURE 3.3. The set C . The bold curves are ∂C . The dashed curve describes the set of points $(\alpha, \beta) \in C$ for which $g_{\alpha, \beta}(t^*(\alpha, \beta)) = 0$.

and let C and D be the open bounded sets whose boundary is given by the Jordan curves $\Gamma_1 \cup \Gamma_2 \cup \{(1, \beta) : \frac{1}{2} \leq \beta \leq 1\}$ and $\Gamma_2 \cup \Gamma_3 \cup \{(\alpha, \alpha) : \frac{1}{6}(3 - \sqrt{3}) \leq \alpha \leq 1\}$, respectively. Set

$$A := \left(H \cup \left\{ (\alpha, 1) : 0 < \alpha \leq \frac{1}{2} \right\} \right) \setminus D$$

and $B := D \setminus (C \cup \{(1, \beta) : 0 \leq \beta \leq \frac{1}{2}\})$ (cf. Figure 3.2).

Further, for $\alpha, \beta \in \mathbb{R}$ and $t > 0$ define $g_{\alpha, \beta}(t) := g_{\alpha}(t) - g_{\beta}(t)$, where

$$g_{\alpha}(t) := t^{\alpha-1} [(1-\alpha)^2 t^2 + (1+2\alpha-2\alpha^2)t + \alpha^2] - t - 1, \quad (3.3)$$

and, for $\alpha, \beta \in \mathbb{R} \setminus \{1\}$ with $\varepsilon_2(\alpha, \beta)\varepsilon_3(\alpha, \beta) \leq 0$, let

$$t^*(\alpha, \beta) = \frac{\varepsilon_2(\alpha, \beta) - 2\alpha\beta(1-\alpha)(1-\beta) + \sqrt{-\varepsilon_2(\alpha, \beta)\varepsilon_3(\alpha, \beta)}}{2(1-\alpha)^2(1-\beta)^2}.$$

The next theorem contains a complete description of the set \mathfrak{C} .

THEOREM 3.5. (1) For $(\alpha, \beta) \in A$ the function $f_{\alpha, \beta}(x)$ is convex in $(0, \infty)$ and for $(\alpha, \beta) \in A^*$ it is concave there.

(2) For $(\alpha, \beta) \in B \cup B^*$ the function $f''_{\alpha, \beta}(x)$ changes sign in $(0, \infty)$.

(3) In $C \cup C^*$ the sign of $f''_{\alpha, \beta}(x)$ is constant in $(0, \infty)$ if, and only if, $(\alpha, \beta) \in C_{conv} \cup C^*_{conv}$, where

$$C_{conv} := \{(\alpha, \beta) \in C : g_{\alpha, \beta}(t^*(\alpha, \beta)) \geq 0\}.$$

$f_{\alpha, \beta}(x)$ is convex in $(0, \infty)$ if $(\alpha, \beta) \in C_{conv}$ and concave if $(\alpha, \beta) \in C^*_{conv}$ (cf. Figure 3.3).

Before we turn to the proof of this theorem, note that, since

$$f_{\alpha, \beta}(-x) = f_{1-\beta, 1-\alpha}(x),$$

Theorems 3.2 and 3.5 can also be used to give a complete description of all points $(\alpha, \beta) \in \mathbb{R}^2$ for which the functions $f'_{\alpha, \beta}(x)$ and $f''_{\alpha, \beta}(x)$ are of constant sign in $(-\infty, 0)$ or $(-\infty, \infty)$.

As in the proof of Theorem 3.2 we see that in order to verify Theorem 3.5 it will be enough to examine the concavity of $f_{\alpha,\beta}(x)$ in $(0, \infty)$ for (α, β) in the interior of H . Further, since

$$f''_{\alpha,\beta}(x) = \frac{e^x g_{\alpha,\beta}(e^x)}{(e^x - 1)^3}, \quad x \geq 0, \quad (3.4)$$

the concavity of $f_{\alpha,\beta}(x)$ in $(0, \infty)$ is completely determined by the sign of $g_{\alpha,\beta}(t)$ in $(1, \infty)$. Therefore the next four lemmas give a proof of Theorem 3.5.

LEMMA 3.6. *For $\alpha < 0$ the function $g_\alpha(t)$ is negative in $(1, \infty)$ and for $\alpha \in (0, \frac{1}{2}] \cup (1, \infty)$ the function $g_\alpha(t)$ is positive in $(1, \infty)$. For $\alpha \in (\frac{1}{2}, 1)$ the function $g_\alpha(t)$ changes sign in $(1, \infty)$.*

PROOF. For all $\alpha \in \mathbb{R}$ we have $g_\alpha(1) = 0$ and

$$\begin{aligned} g'_\alpha(t) &= (\alpha - 1)^2(\alpha + 1)t^\alpha + (-2\alpha^3 + 2\alpha^2 + \alpha)t^{\alpha-1} \\ &\quad + \alpha^2(\alpha - 1)t^{\alpha-2} - 1, \\ g''_\alpha(t) &= \alpha(\alpha - 1)t^{\alpha-3}(t - 1)((\alpha^2 - 1)t - \alpha(\alpha - 2)), \\ g'''_\alpha(1) &= \alpha(\alpha - 1)(2\alpha - 1). \end{aligned}$$

Consequently, for all $\alpha \in \mathbb{R}$, $g'_\alpha(1) = g''_\alpha(1) = 0$.

The case $\alpha \in [-1, \frac{1}{2}] \cup (1, \infty)$. In this case g''_α does not vanish in $(1, \infty)$ and thus the sign of g'_α in $(1, \infty)$ will be equal to the sign of $g'''_\alpha(1)$. For $\alpha \in [-1, 0)$ we have $g'''_\alpha(1) < 0$, whereas $g'''_\alpha(1) > 0$ for $\alpha \in (0, \frac{1}{2}) \cup (1, \infty)$. Therefore, since moreover $g_{\frac{1}{2}}^{(4)}(1) = \frac{3}{8}$, g_α is negative in $(1, \infty)$ if $\alpha \in [-1, 0)$ and positive if $\alpha \in (0, \frac{1}{2}] \cup (1, \infty)$.

The case $\alpha \in (-\infty, -1)$. In this case g''_α has exactly one zero t_α in $(1, \infty)$. Since $g'''_\alpha(1) < 0$, it follows that $g''_\alpha < 0$ in $(1, \infty)$ if and only if $t \in (1, t_\alpha)$. Since $g'_\alpha(t) \rightarrow -1$ as $t \rightarrow \infty$, this shows that g'_α is negative in $(1, \infty)$. Hence, for $\alpha \in (-\infty, -1)$, g_α is negative in $(1, \infty)$.

The case $\alpha \in (\frac{1}{2}, 1)$. In this case we have $g'''_\alpha(1) < 0$ and thus $g_\alpha(t) < 0$ for all $t > 1$ sufficiently close to 1. Since $t^{-(1+\alpha)}g_\alpha(t) \rightarrow (1 - \alpha)^2 > 0$ as $t \rightarrow \infty$, the proof of the lemma is complete. \square

LEMMA 3.7. *For $(\alpha, \beta) \in B \setminus \Gamma_1$ the sign of $g_{\alpha,\beta}(t)$ changes on $(1, \infty)$.*

PROOF. Since $g_{1,\beta}(t) = -g_\beta(t)$, the case $\alpha = 1$ of our assertion follows from lemma 3.6. For the other (α, β) in question we have $\alpha \neq 1$ and $\alpha > \beta$ and thus

$$\lim_{t \rightarrow \infty} t^{-(1+\alpha)}g_{\alpha,\beta}(t) = (1 - \alpha)^2 > 0.$$

It will therefore be enough to show that $g_{\alpha,\beta}(t)$ takes negative values in $(1, \infty)$ for $(\alpha, \beta) \in B$ with $\alpha \neq 1$.

We have $g_{\alpha,\beta}^{(n)}(1) = 0$ for $n = 0, 1, 2$ and

$$\frac{g_{\alpha,\beta}^{(3)}(1)}{\alpha - \beta} = \varepsilon_1(\alpha, \beta).$$

Consequently, for

$$(\alpha, \beta) \in \{(\alpha, \beta) : \beta < \alpha, \varepsilon_1(\alpha, \beta) < 0\},$$

$g_{\alpha,\beta}(t)$ takes negative values in $(1, \infty)$ and it only remains to show that the same is true for (α, β) in the triangle $\{(\alpha, \beta) : \frac{1}{2} < \beta < \alpha < 1\}$.

To this end, fix a $\beta \in (\frac{1}{2}, 1)$ and observe that by Lemma 3.6 there is a $t^* \in (1, \infty)$ such that $g_\beta(t^*) = 0$. Since

$$g_{\alpha,\beta}(t^*) = g_\alpha(t^*) - g_\beta(t^*) = g_\alpha(t^*),$$

our claim will follow once we have shown that the function $h(\alpha) := g_\alpha(t^*)$, $\alpha \in (\frac{1}{2}, 1)$, is negative for all $\alpha \in (\beta, 1)$. We calculate

$$\begin{aligned} (t^*)^{1-\alpha} h'(\alpha) &= 2(t^* - 1)(\alpha(t^* - 1) - t^*) \\ &\quad + (\alpha^2(t^* - 1)^2 - 2t^*\alpha(t^* - 1) + t^*(t^* + 1)) \log t^* \end{aligned}$$

and thus $h'(\alpha)$ vanishes for those α for which the rational function

$$r(\alpha) := \frac{\alpha^2(t^* - 1)^2 - 2t^*\alpha(t^* - 1) + t^*(t^* + 1)}{\alpha(t^* - 1) - t^*}$$

cuts the horizontal $\alpha \mapsto 2(1 - t^*)/\log t^*$. It is straightforward to verify that, in $(\frac{1}{2}, 1)$, $r(\alpha)$ has no pole and

$$r'(\alpha) = \frac{(t^* - 1)^2(\alpha^2(t^* - 1) - 2t^*\alpha + t^*)}{(\alpha(t^* - 1) - t^*)^2}$$

has exactly one zero and hence h can have at most two local extrema in $(\frac{1}{2}, 1)$.

Now, suppose that $h'(\beta) > 0$. Then, since $h(1) = 0$ and

$$h'(1) = (t^* + 1) \log t^* + 2(1 - t^*) > 0$$

for all $t^* \in (1, \infty)$, h must have at least two local extrema in $(\beta, 1)$. On the other hand, $4\sqrt{t^*}h(\frac{1}{2}) = (\sqrt{t^*} - 1)^4 > 0$ and $h(\beta) = 0$, and hence $h(\alpha)$ has to have at least one local minimum in $(\frac{1}{2}, \beta)$. But $h(\alpha)$ can have at most two local extrema in $(\frac{1}{2}, 1)$ and therefore $h'(\beta) < 0$. If now $h(\alpha) > 0$ would hold for an $\alpha \in (\beta, 1)$, then, since $h(1) = 0$ and $h'(1) > 0$, $h(\alpha)$ would have to have more than two local extrema in $(\beta, 1)$. Thus, we must have $h(\alpha) < 0$ for all $\alpha \in (\beta, 1)$ and the proof of the lemma is complete. \square

LEMMA 3.8. *For $(\alpha, \beta) \in H \setminus D$ we have $g_{\alpha,\beta}(t) \geq 0$ in $(1, \infty)$ and for $\beta \in [0, \frac{1}{2}]$ the function $g_{1,\beta}(t)$ is non-positive in $(1, \infty)$.*

PROOF. The case $\alpha = \beta$ is trivial and since $g_{\alpha,1}(t) = g_\alpha(t)$ and $g_{1,\beta}(t) = -g_\beta(t)$, the cases $\alpha = 1$ and $\beta = 1$ of our assertion follow from Lemma 3.6.

In order to prove the lemma also for the other (α, β) in question, set

$$h_\alpha(t) := (1 - \alpha)^2 t^2 + (1 + 2\alpha - 2\alpha^2)t + \alpha^2, \quad \alpha, t \in \mathbb{R}.$$

The parabola $h_\alpha(t)$ opens upward and satisfies $h_\alpha(1) = 2$ for all $\alpha \in \mathbb{R}$, its discriminant is non-negative exactly for $\frac{1}{2}(1 - \sqrt{2}) \leq \alpha \leq \frac{1}{2}(1 + \sqrt{2}) < \frac{3}{2}$, and $h'_\alpha(1) > 0$ exactly if $\alpha < \frac{3}{2}$. Hence, $h_\alpha(t) > 0$ for all $\alpha \in \mathbb{R}$ and $t > 1$ and therefore $g_{\alpha,\beta}(t) \geq 0$ is equivalent to

$$\log h_\alpha(t) - \log h_\beta(t) \geq (\beta - \alpha) \log t.$$

Since this inequality holds for all $(\alpha, \beta) \in \mathbb{R}$ when $t = 1$, it will suffice to prove that

$$\frac{h'_\alpha(t)}{h_\alpha(t)} - \frac{h'_\beta(t)}{h_\beta(t)} \geq \frac{\beta - \alpha}{t}, \quad (3.5)$$

or

$$th'_\alpha(t)h_\beta(t) - th'_\beta(t)h_\alpha(t) + (\alpha - \beta)h_\alpha(t)h_\beta(t) \geq 0 \quad \text{for } t > 1.$$

The left-hand side of the latter inequality is equal to $(\alpha - \beta)(1 - t)^2 p_{\alpha,\beta}(t)$, where

$$p_{\alpha,\beta}(t) = t^2(1 - \alpha)^2(1 - \beta)^2 + t(\beta(\beta - 1) + (\alpha^2 - \alpha)(1 - 2\beta(\beta - 1))) + \alpha^2\beta^2,$$

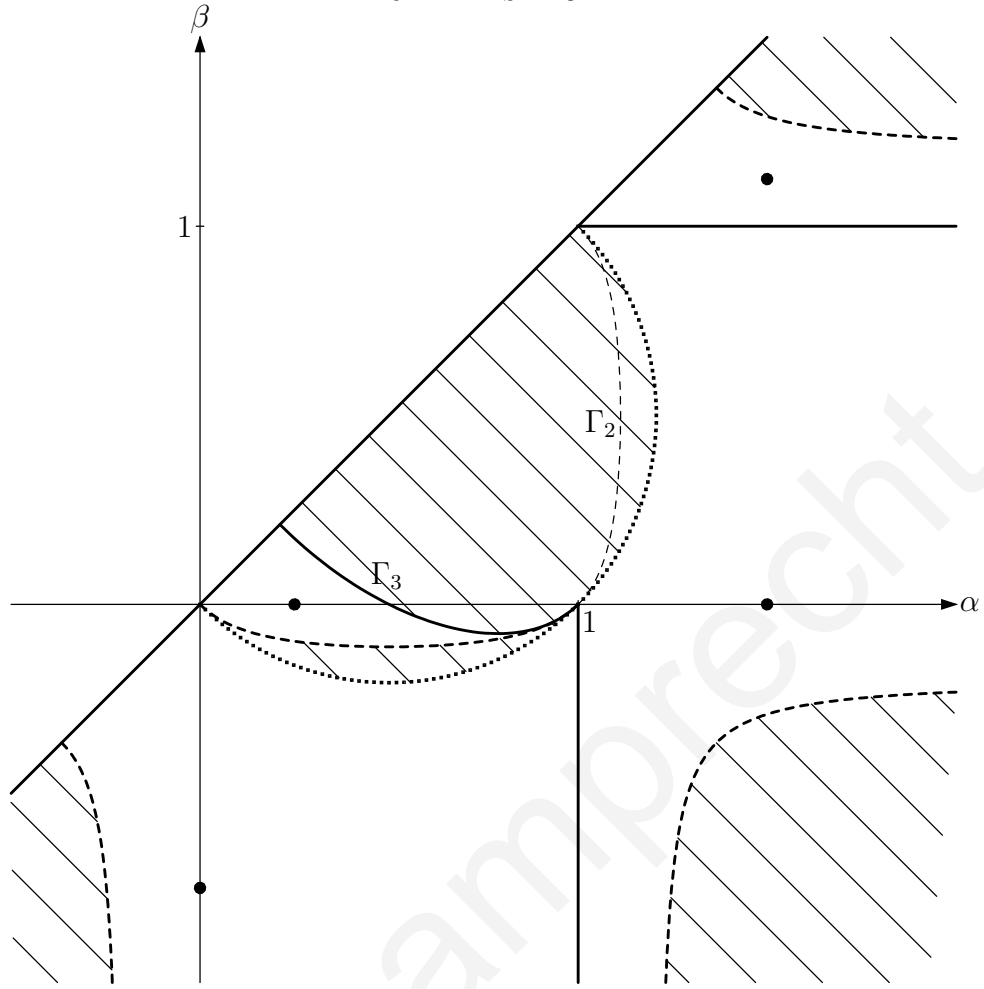

FIGURE 3.4. The sets P and N . The interior of P is hatched. The bold curves are ∂N . The dotted arc describes the set $H \cap \{(\alpha, \beta) : \varepsilon_3(\alpha, \beta) = 0\}$. The dashed curves describes the set $H \cap \{(\alpha, \beta) : \varepsilon_2(\alpha, \beta) = 0\}$. The four dots describe the location of the points q_1, \dots, q_4 .

so that (3.5) is equivalent to

$$p_{\alpha, \beta}(t) \geq 0 \quad \text{for } t > 1.$$

The discriminant of the parabola (in the following we will always assume that $\alpha \neq 1$ and $\beta \neq 1$) $p_{\alpha, \beta}(t)$ is equal to $-\varepsilon_2(\alpha, \beta)\varepsilon_3(\alpha, \beta)$. Since $p_{\alpha, \beta}(t)$ opens upward, it therefore follows that the non-negativity of $p_{\alpha, \beta}(t)$ in $(1, \infty)$ remains to be verified only for $(\alpha, \beta) \in N := H \setminus P$, where (cf. Figure 3.4)

$$P := D \cup \{(\alpha, \beta) : \varepsilon_2(\alpha, \beta)\varepsilon_3(\alpha, \beta) \geq 0\} \cup \{(1, \beta) : \beta \in \mathbb{R}\} \cup \{(\alpha, 1) : \alpha \in \mathbb{R}\}.$$

A straightforward computation shows that if $p_{\alpha, \beta}(t)$ has a zero at 1, then $\varepsilon_1(\alpha, \beta) = 0$ must hold. Since $\{(\alpha, \beta) : \varepsilon_1(\alpha, \beta) = 0\} \cap H$ is contained in \overline{D} , a continuity argument yields that the number of zeros of $p_{\alpha, \beta}(t)$ in $[1, \infty)$ is constant in each component of N .

It is easy to see that N consists of exactly 4 components and that no two of the points $q_1 := (\frac{1}{4}, 0)$, $q_2 := (\frac{3}{2}, 0)$, $q_3 := (0, -\frac{3}{4})$ and $q_4 := (\frac{3}{2}, \frac{9}{8})$ lie in the same component of N (cf. Figure 3.4). Since one readily verifies that $p_{q_j}(t)$ has no zeros in $(1, \infty)$ for $j = 1, \dots, 4$, it follows that $p_{\alpha, \beta}(t)$ is positive in $(1, \infty)$ for all $(\alpha, \beta) \in N$.

The proof of the lemma is complete. \square

LEMMA 3.9. *The function $f_{\alpha,\beta}(x)$ is convex on $(0, \infty)$ if $(\alpha, \beta) \in C_{conv}$. For $(\alpha, \beta) \in C \setminus C_{conv}$ and $(\alpha, \beta) \in \Gamma_1$ the sign of $f''_{\alpha,\beta}(x)$ changes on $(0, \infty)$.*

PROOF. It follows from the proof of Lemma 3.8 that, for a pair $(\alpha, \beta) \in \mathbb{R}^2$ and a $t > 1$, $g_{\alpha,\beta}(t) \geq 0$ if, and only if,

$$l_{\alpha,\beta}(t) := \log h_\alpha(t) - \log h_\beta(t) - (\beta - \alpha) \log t \geq 0$$

and that $l_{\alpha,\beta}(t)$ has a critical point t in $(1, \infty)$ if, and only if, t is a zero of $p_{\alpha,\beta}(t)$. Furthermore, since one easily checks that $\alpha, \beta \neq 1$ and $\varepsilon_1(\alpha, \beta) \neq 0$ for all (α, β) in the connected set C , the proof of Lemma 3.8 also shows that the number of zeros of $p_{\alpha,\beta}(t)$ in $[1, \infty)$ is constant in C . It is readily verified that $q_5 := (\frac{11}{10}, \frac{1}{2}) \in C$ (cf. Figure 3.3) and that $p_{q_5}(t)$ has exactly two zeros in $(1, \infty)$. Hence, for $(\alpha, \beta) \in C$, $l_{\alpha,\beta}(t)$ has exactly two local extrema in $(1, \infty)$. Since $\beta < \alpha \neq 1$ in C , it follows from the proof of Lemma 3.7 that $l_{\alpha,\beta}(t)$ is positive for all t large enough. Since, moreover, $l_{\alpha,\beta}(1) = 0$ for all $(\alpha, \beta) \in \mathbb{R}^2$, the largest one, say t^* , of the critical points of $l_{\alpha,\beta}(t)$ in $[1, \infty)$ must be a local minimum of $l_{\alpha,\beta}(t)$ and $l_{\alpha,\beta}(t)$ will be non-negative in $(1, \infty)$ if, and only if, $l_{\alpha,\beta}(t^*) \geq 0$ (or, equivalently, $g_{\alpha,\beta}(t^*) \geq 0$). t^* must be the largest zero of $p_{\alpha,\beta}(t)$ and can thus be calculated to be $t^*(\alpha, \beta)$.

The set Γ_1 belongs to the boundary of both C and E , where E is the open bounded set that has the Jordan curve $\Gamma_1 \cup \{(1, \beta) : 0 \leq \beta \leq \frac{1}{2}\}$ as its boundary (E is shaded in Figure 3.3). The point $q_6 := (\frac{101}{100}, \frac{1}{4})$ lies in E and $p_{q_6}(t)$ has exactly one zero in $(1, \infty)$. Hence, on Γ_1 , at least one of the zeros of $p_{\alpha,\beta}(t)$ is equal to 1. Since $\varepsilon_2(\alpha, \beta)\varepsilon_3(\alpha, \beta) \neq 0$ for $(\alpha, \beta) \in \Gamma_1$, the function $p_{\alpha,\beta}(t)$ can not have a double zero at $t^*(\alpha, \beta)$ on Γ_1 . Therefore $t^*(\alpha, \beta)$ is the only critical point of $g_{\alpha,\beta}(t)$ in $(1, \infty)$ when $(\alpha, \beta) \in \Gamma_1$. Since, for $(\alpha, \beta) \in \Gamma_1$, $g_{\alpha,\beta}(1) = 0$ and $g_{\alpha,\beta}(t) \rightarrow \infty$ as $t \rightarrow \infty$, this means that we must have $g_{\alpha,\beta}(t^*(\alpha, \beta)) < 0$ for $(\alpha, \beta) \in \Gamma_1$. \square

3.3. On the Third Derivative of $f_\alpha(x)$

In this section we will give a short proof of a result concerning the functions $f_\alpha(x)$ that was used in [KL09a] in order to verify the complete monotonicity in $(0, \infty)$ of the functions ξ from Section 2.2 for $\mu \in [\frac{1}{3}, \frac{1}{2})$.

It follows from Theorem 3.5 that for $\mu \in (0, \frac{1}{2})$ the function $\phi''_{1,\mu}(u)$ changes sign in $(0, \infty)$. Hence, for those parameters, one can not argue like we did in the introduction of this chapter in order to show that the function

$$L_{1,\mu}(x) = x - \frac{\Gamma(x + \mu)}{\Gamma(x + 1)} x^{2-\mu} = \xi(x)$$

is increasing in $(0, \infty)$. In fact, as mentioned in the second chapter, it is shown in [KL09a] that for $\mu \in (0, \frac{1}{3})$ the function $\xi'(x)$ is negative for x close to ∞ and positive for x close to 0. For $\mu \in [\frac{1}{3}, \frac{1}{2})$, however, $\xi'(x)$ remains completely monotonic. This was shown in [KL09a], where the following lemma was used in a clever way in order to verify the positivity of

$$F''(u) = u\phi''_{1,\mu}(u) + \int_0^u \phi'_{1,\mu}(u-v)\phi'_{1,\mu}(v)dv,$$

and therefore also the complete monotonicity of $-L''_{1,\mu}(x)$, in $(0, \infty)$ for $\mu \in [\frac{1}{3}, \frac{1}{2})$.

LEMMA 3.10. *Let $\alpha \in (\frac{1}{2}, \frac{2}{3}]$. Then $f''_\alpha(x) > 0$ for $x \in [1, \infty)$ and $f'''_\alpha(x) > 0$ for $x \in (0, 1]$.*

We give a proof of this lemma that is considerably simpler than the one presented in [KL09a].

First note that, since

$$f_\alpha'''(x) = \frac{e^x l_\alpha(e^x)}{(e^x - 1)^4}, \quad x \in \mathbb{R}, \quad (3.6)$$

with

$$l_\alpha(t) := t^\alpha \left((\alpha - 1)^3 t^2 + (-3\alpha^3 + 6\alpha^2 - 4)t + (3\alpha^3 - 3\alpha^2 - 3\alpha - 1) - \alpha^3 t^{-1} \right) + t^2 + 4t + 1,$$

the sign of $f_\alpha'''(x)$ in $(0, \infty)$ is completely determined by the sign of $l_\alpha(t)$ in $(1, \infty)$.

LEMMA 3.11. *For every $\alpha \in (\frac{1}{2}, \frac{2}{3}]$ there is a $t^* > 1$ such that $l_\alpha(t)$ is positive in $(1, t^*)$ and negative in (t^*, ∞) .*

PROOF. Set $v_\alpha(t) := t^{4-\alpha} l_\alpha'''(t)$. Then

$$\begin{aligned} \frac{v_\alpha(t)}{\alpha(\alpha - 1)} &= (\alpha + 2)(\alpha + 1)(\alpha - 1)^2 t^3 - (\alpha + 1)(3\alpha^3 - 6\alpha^2 + 4)t^2 \\ &\quad + (\alpha - 2)(3\alpha^3 - 3\alpha^2 - 3\alpha - 1)t - \alpha^2(\alpha - 2)(\alpha - 3) \end{aligned}$$

and thus, for $\alpha \in (\frac{1}{2}, \frac{2}{3}]$, $v_\alpha(t)$ is a polynomial of degree 3. Since for $\alpha \in (\frac{1}{2}, \frac{2}{3}]$ we have $v_\alpha(1) = 0$, $v_\alpha'(1) = 6\alpha^2(1 - \alpha)^2 > 0$, and

$$\lim_{t \rightarrow \infty} t^{-3} v_\alpha(t) = \alpha(\alpha + 2)(\alpha + 1)(\alpha - 1)^3 < 0$$

and since a polynomial of degree 3 has at most two local extrema in \mathbb{R} , we find that $l_\alpha'''(t)$ has exactly one zero in $(1, \infty)$. Since $l_\alpha^{(j)}(1) = 0$ for all $\alpha \in \mathbb{R}$ and $j \in \{0, 1, 2\}$ and since

$$\lim_{t \rightarrow \infty} t^{-(2+\alpha)} l_\alpha(t) = (\alpha - 1)^3 < 0$$

for $\alpha \in (0, 1)$, this implies that for each $\alpha \in (\frac{1}{2}, \frac{2}{3}]$ there is a $t^* > 1$ such that $l_\alpha(t)$ is positive in $(1, t^*)$ and negative in (t^*, ∞) . \square

LEMMA 3.12. *For $\alpha \in (\frac{1}{2}, \frac{2}{3}]$ we have $l_\alpha(e) > 0$ and $g_\alpha(e) > 0$ (where $g_\alpha(t)$ is the function defined in (3.3)).*

PROOF. Since $l_{\frac{1}{2}}(e)$ and $l_{\frac{2}{3}}(e)$ are positive and since

$$e^{1-\alpha} \frac{d}{d\alpha} l_\alpha(e) = (e - 1)^3 \alpha^3 - 3(e - 1)^2 \alpha^2 - 3e(e - 1)(e - 3)\alpha + 2e^3 - 4e^2 - 4e$$

is a polynomial of degree 3 in α that has exactly one zero in $(\frac{1}{2}, \frac{2}{3}]$ and is positive at $\alpha = \frac{1}{2}$, it follows that $l_\alpha(e) > 0$ for $\alpha \in (\frac{1}{2}, \frac{2}{3}]$.

In the same way, since

$$e^{1-\alpha} \frac{d}{d\alpha} g_\alpha(e) = (e - 1)^2 \alpha^2 + 2(1 - e)\alpha - e^2 + 3e$$

is a parabola in α that does not vanish in $(\frac{1}{2}, \frac{2}{3}]$ and since $g_{\frac{1}{2}}(e)$ and $g_{\frac{2}{3}}(e)$ are positive, we find that $g_\alpha(e) > 0$ for $\alpha \in (\frac{1}{2}, \frac{2}{3}]$. \square

Now, because of Lemma 3.12 the $t^* > 1$ that has been found in Lemma 3.11 has to be larger than e . By (3.6) this means that, for $\alpha \in (\frac{1}{2}, \frac{2}{3}]$, $f_\alpha'''(x)$ is positive in $(0, 1]$ and $f_\alpha''(x)$ has exactly one local extremum (a local maximum) in $[1, \infty)$. This completes the proof of Lemma 3.10, since it follows from (3.4), Lemma 3.12 and the case $\alpha \in (\frac{1}{2}, 1)$ of Lemma 3.6 that $f_\alpha''(1) > 0$ and $f_\alpha''(x) > 0$ for x close to ∞ when $\alpha \in (\frac{1}{2}, \frac{2}{3}]$.

Martin Lamprecht

On Suffridge's Polynomial Classes

The *convolution* of two functions

$$f(z) = \sum_{k=0}^{\infty} a_k z^k \quad \text{and} \quad g(z) = \sum_{k=0}^{\infty} b_k z^k$$

that are analytic in a disk D centered at the origin of the complex plane \mathbb{C} is defined as

$$(f * g)(z) := \sum_{k=0}^{\infty} a_k b_k z^k$$

and is itself analytic in D .

Two of the most important and beautiful convolution results are the theorem of Grace and the theorem of Ruscheweyh and Sheil-Small.

THEOREM 4.1 (Grace). *Let*

$$P(z) = \sum_{k=0}^n \binom{n}{k} a_k z^k \quad \text{and} \quad Q(z) = \sum_{k=0}^n \binom{n}{k} b_k z^k$$

be two polynomials of degree n that have all their zeros in the closed unit disk $\overline{\mathbb{D}}$. Then all zeros of

$$P * Q * \sum_{k=0}^n \frac{1}{\binom{n}{k}} z^k = \sum_{k=0}^n \binom{n}{k} a_k b_k z^k$$

lie also in $\overline{\mathbb{D}}$.

THEOREM 4.2 (Ruscheweyh and Sheil-Small). *If f and g lie in the set \mathcal{K} of convex functions, then $f * g$ is also convex.*

Here, the class \mathcal{K} of *convex functions* is defined to be the set of all functions $f \in \mathcal{A}_0$ that map the unit disk \mathbb{D} univalently onto a convex domain.

The original result of Grace can be found in [Gra02]. The version that we present here is due to Szegő [Sze22]. See also [Lam05, Ch. 2], [SS02, Ch. 5], and [RS02, Ch. 3]. Pólya and Schoenberg stated Theorem 4.2 as a conjecture in [PS58]; 15 years later this conjecture was settled by Ruscheweyh and Sheil-Small in [RSS73].

In [Suf76] Suffridge showed that there is a close connection between the theorem of Grace and the theorem of Ruscheweyh and Sheil-Small; this connection will be outlined in the next two pages (a different way of deriving Theorem 4.6 below from the theorem of Grace can be found in [Rus82, Ch. 1, 2] and [SS02, Ch. 8]):

For $n \in \mathbb{N}$ and $\lambda \in [0, \frac{2\pi}{n}]$ let $\mathcal{P}_n(\lambda)$ be the set of polynomials

$$P(z) = \sum_{k=0}^n A_k z^k$$

of degree n that are normalized by $A_0 = A_n = 1$ and can be written in the form

$$P(z) = \prod_{j=1}^n (1 + e^{i\alpha_j} z)$$

with $\alpha_j + \lambda \leq \alpha_{j+1}$ for $j \in \{1, \dots, n\}$ ($\alpha_{n+1} := \alpha_1 + 2\pi$). In other words, a normalized polynomial P of degree n is in $\mathcal{P}_n(\lambda)$ if all its zeros lie on the unit circle \mathbb{T} and each pair of its zeros is separated by an angle of at least λ . Thus, for instance, $P_n(\frac{2\pi}{n}) = \{1 + z^n\}$ and $P \in \mathcal{P}_n(0)$ if, and only if, P is normalized and has all its zeros on \mathbb{T} .

Natural extremal elements in $\mathcal{P}_n(\lambda)$ are those polynomials for which each – except one – pair of consecutive zeros is separated by an angle of exactly λ . Setting

$$Q_n(\lambda; z) := \sum_{k=0}^n \binom{n}{k}_\lambda z^k := \prod_{j=1}^n (1 + e^{i(2j-n-1)\lambda/2} z),$$

it is easy to see that the polynomials in $\mathcal{P}_n(\lambda)$ which have this property are exactly $Q_n(\lambda; e^{2\pi ik/n} z)$, $k \in \{1, \dots, n\}$, the so-called *rotations of $Q_n(\lambda; z)$* . $Q_n(\lambda; z)$ is distinguished by the fact that its zeros lie symmetrical with respect to -1 . By definition $\binom{n}{k}_0 = \binom{n}{k}$ and by induction one readily verifies (cf. [Suf76] or [SS02, p. 252]) that for $\lambda \in (0, \frac{2\pi}{n})$ and $k \in \{0, \dots, n\}$

$$\binom{n}{k}_\lambda = \frac{\prod_{j=1}^n \sin \frac{j\lambda}{2}}{\prod_{j=1}^k \sin \frac{j\lambda}{2} \prod_{j=1}^{n-k} \sin \frac{j\lambda}{2}}. \quad (4.1)$$

Therefore $\binom{n}{k}_\lambda \neq 0$ for $\lambda \in [0, \frac{2\pi}{n})$ and $k \in \{0, \dots, n\}$ and we can set

$$Q_n^{(-1)}(\lambda; z) := \sum_{k=0}^n \frac{1}{\binom{n}{k}_\lambda} z^k, \quad \lambda \in \left[0, \frac{2\pi}{n}\right).$$

For $\lambda \in [0, \frac{2\pi}{n})$ the *Suffridge class* $\mathcal{S}_n(\lambda)$ is now defined to be the set of polynomials p of degree n for which $p * Q_n(\lambda; z)$ is in $\mathcal{P}_n(\lambda)$. The existence of $Q_n^{(-1)}(\lambda; z)$ – the convolution inverse of $Q_n(\lambda; z)$ – shows that $\mathcal{S}_n(\lambda)$ is homeomorphic to $\mathcal{P}_n(\lambda)$ if we identify the set \mathcal{P}_n of complex polynomials of degree $\leq n$ with the Banach space \mathbb{C}^{n+1} . For reasons that will become clear later on, we also set

$$\mathcal{S}_n \left(\frac{2\pi}{n} \right) := \text{co} \{ e_n(e^{2\pi ik/n} z) : k \in \{1, \dots, n\} \}, \quad (4.2)$$

where $e_n(z) := 1 + z + z^2 + \dots + z^n$. Here, for any subset M of a complex vector space, $\text{co } M$ denotes the convex hull of M .

Suffridge's main results from [Suf76] now read as follows.

THEOREM 4.3 (Suffridge). *Let $\lambda \in [0, \frac{2\pi}{n}]$.*

- (1) *If $p, q \in \mathcal{S}_n(\lambda)$, then also $p * q \in \mathcal{S}_n(\lambda)$.*
- (2) *If $\lambda < \mu \leq \frac{2\pi}{n}$, then $\mathcal{S}_n(\lambda)$ is contained in the interior of $\mathcal{S}_n(\mu)$.*

For two polynomials P and Q of degree n and $\lambda \in [0, \frac{2\pi}{n})$ we define

$$P *_\lambda Q := P * Q * Q_n^{(-1)}(\lambda; z).$$

Note that $*_\lambda$ depends on the degree of P and Q . Suffridge's convolution theorem 4.3 (1) can thus be written in the following (nearly) equivalent form.

THEOREM 4.4 (Suffridge's convolution theorem). *If $\lambda \in [0, \frac{2\pi}{n})$ and $P, Q \in \mathcal{P}_n(\lambda)$, then also*

$$P *_{\lambda} Q \in \mathcal{P}_n(\lambda).$$

The *inverse* P^* of a polynomial $P(z) = \sum_{k=0}^n A_k z^k$ of degree n is defined by

$$P^*(z) := z^n \overline{P\left(\frac{1}{\bar{z}}\right)} = \sum_{k=0}^n \overline{A_{n-k}} z^k \quad (4.3)$$

and P is called *self-inversive* if $P = P^*$ (note that P^* depends on the degree of P). It follows immediately that P is self-inversive if, and only if, its coefficients A_k satisfy the symmetry relation $A_k = \overline{A_{n-k}}$ for $k \in \{0, \dots, n\}$. It is also clear that the zeros of P^* are obtained by reflecting the zeros of P with respect to the unit circle. Therefore the zeros of a self-inversive polynomial P lie symmetrical with respect to \mathbb{T} and to each polynomial P whose zeros lie symmetrical with respect to \mathbb{T} there is a constant $c \in \mathbb{T}$ such that cP is self-inversive [SS02, Sec. 7.1.1]. In particular, all classes $\mathcal{P}_n(\lambda)$ and $\mathcal{S}_n(\lambda)$, $\lambda \in [0, \frac{2\pi}{n}]$, contain only self-inversive polynomials. We denote the set of self-inversive polynomials of degree n by \mathcal{S}_n and the set of $P \in \mathcal{S}_n$ which satisfy $P(0) = 1$ by \mathcal{S}_n^1 .

A straightforward application of the two characterizations of self-inversiveness (symmetry of coefficients and symmetry of zeros) shows that the zeros of a convolution of two polynomials in \mathcal{S}_n lie symmetric with respect to the unit circle. It therefore follows from the theorem of Grace that for P and Q in $\mathcal{P}_n(0)$ the convolution $P *_0 Q$ is also in $\mathcal{P}_n(0)$. This proves the case $\lambda = 0$ of Theorem 4.4 and constitutes the basis of Suffridge's proof of the remaining case $\lambda \in (0, \frac{2\pi}{n})$.

A function $f \in \mathcal{A}_0$ is said to lie in the class \mathcal{R}_α of functions *pre-starlike of order* $\alpha < 1$ if $f * f_{2-2\alpha}$ lies in the set \mathcal{S}_α^* of functions starlike of order α (here f_λ is defined as in (2.2)). As shown in [Rus82, p. 48], $f \in \mathcal{R}_\alpha$ if, and only if, $f \in \mathcal{A}_0$ and

$$\operatorname{Re} \frac{f * f_{3-2\alpha}(z)}{f * f_{2-2\alpha}(z)} > \frac{1}{2}, \quad z \in \mathbb{D}.$$

This is one reason why one defines the class \mathcal{R}_1 of functions pre-starlike of order 1 as the set of those functions $f \in \mathcal{A}_0$ for which $\operatorname{Re} \frac{f}{z} > \frac{1}{2}$ in the unit disk. We have the relations $\mathcal{R}_0 = \mathcal{K}$ and $\mathcal{R}_{1/2} = \mathcal{S}_{1/2}^*$ [Rus82, p. 49].

Pre-starlike functions appeared first in [Suf76] where the following approximation result was shown (see also [SS02, 7.6.8]).

THEOREM 4.5.

- (1) $f \in \mathcal{A}_0$ is pre-starlike of order $\alpha \leq 1$ if, and only if, there exists a sequence $\{p_{n_k}\}_{k \in \mathbb{N}}$ with $p_{n_k} \in \mathcal{S}_{n_k}(\frac{2\pi}{n_k+2-2\alpha})$ such that $n_k \geq k$ for $k \in \mathbb{N}$ and $zp_{n_k} \rightarrow f$ locally uniformly in \mathbb{D} as $k \rightarrow \infty$.
- (2) For $\mu > 0$ we have

$$\binom{n}{k} \xrightarrow{\frac{2\pi}{n+\mu}} \frac{(\mu)_k}{k!} \quad \text{and} \quad Q_n \left(\frac{2\pi}{n+\mu} \right) \rightarrow \frac{1}{(1-z)^\mu}$$

as $n \rightarrow \infty$.

This, together with Theorem 4.3, enabled Suffridge to prove the following.

THEOREM 4.6 (cf. [Suf76]). *Let $\beta < \alpha \leq 1$.*

- (1) *If $f, g \in \mathcal{R}_\alpha$, then also $f * g \in \mathcal{R}_\alpha$.*
- (2) $\mathcal{R}_\beta \subset \mathcal{R}_\alpha$.

Since $\mathcal{R}_0 = \mathcal{K}$, Suffridge's extension of Grace's theorem thus leads to a generalization of Ruscheweyh and Sheil-Small's theorem.

The theorem of Gauß-Lucas (cf. [SS02, Ch. 2] or [RS02, Ch. 2]), perhaps the most well-known fact concerning complex polynomials (besides the fact that each polynomial of degree n has exactly n zeros), is usually applied in some way or other in order to prove the theorem of Grace.

THEOREM 4.7 (Gauß-Lucas). *Let P be a polynomial of degree n that has all its zeros in the closed unit disk $\overline{\mathbb{D}}$. Then all zeros of P' lie also in $\overline{\mathbb{D}}$. P' has a zero z on the unit circle \mathbb{T} if, and only if, z is a multiple zero of P .*

If $\lambda \in (0, \frac{2\pi}{n})$ and if $P(z) = \sum_{k=0}^n \binom{n}{k}_\lambda a_k(\lambda) z^k$ is a polynomial of degree n , then we set

$$\Delta_\lambda[P](z) := \frac{P(e^{i\lambda/2}z) - P(e^{-i\lambda/2}z)}{2iz \sin \frac{n\lambda}{2}} = \sum_{k=0}^{n-1} \binom{n-1}{k}_\lambda a_{k+1}(\lambda) z^k,$$

where the second identity follows from (4.1). Note that (4.1) also implies

$$\binom{n}{k}_\lambda \rightarrow \binom{n}{k}, \quad k \in \{0, \dots, n\},$$

as $\lambda \rightarrow 0$ and thus

$$\Delta_\lambda[P](z) \rightarrow \Delta_0[P](z) := \sum_{k=0}^{n-1} \binom{n-1}{k} a_{k+1}(0) z^k = \frac{1}{n} P'(z)$$

locally uniformly in \mathbb{C} as $\lambda \rightarrow 0$. Note also that the operator Δ_λ depends on the degree of the polynomial P . The following extension of the theorem of Gauß-Lucas, found by Suffridge in [Suf76] (see also [SS02, Thm. 7.1.3] for the case $\lambda = 0$), plays a crucial role in the proof of Theorem 4.3.

THEOREM 4.8. *Let $\lambda \in [0, \frac{2\pi}{n})$. A polynomial $P \in \mathcal{S}_n^1$ belongs to $\mathcal{P}_n(\lambda)$ if, and only if, all zeros of $\Delta_\lambda[P]$ lie in the closed unit disk. In such a case $\Delta_\lambda[P]$ has a zero z on the unit circle \mathbb{T} if, and only if, P vanishes at $e^{i\lambda/2}z$ and $e^{-i\lambda/2}z$.*

Suffridge's theorems 4.4 and 4.8 are generalizations of special cases of the theorems of Grace and Gauß-Lucas, respectively. Until now it is unclear whether there are extensions of Theorems 4.4 and 4.8 that generalize the theorems of Grace and Gauß-Lucas themselves. Recently, Ruscheweyh and Salinas (and Sugawa) [RS09, RS10, RSS09] have found some very interesting extensions of Theorem 4.6 to so-called *disk-like domains*, i.e. domains which are the union of disks or halfplanes, all containing the origin. Given the relation between Theorems 4.3 and 4.6, it seems possible that there are extensions or modifications of Theorem 4.3 that lead to a second way of proving some of Ruscheweyh and Salinas' results from [RS09, RS10, RSS09].

In this chapter we will present several minor results that deal with the problem of extending Suffridge's theorems 4.4 and 4.8 to larger polynomial classes. We will mainly consider questions concerning polynomials of the form $\Delta_\lambda[P]$ with $P \in \mathcal{P}_n(\lambda)$. More explicitly, in our main result we shall prove that for $P \in \mathcal{P}_n(\lambda)$ and $Q \in \mathcal{P}_{n-1}(\lambda)$ all zeros of $\Delta_\lambda P *_\lambda Q$ lie in the closed unit disk. We shall also show that there seems to be no reasonable extension of Laguerre's theorem (a generalization of the theorem of Gauß-Lucas) to the classes $\mathcal{P}_n(\lambda)$ and we will give an answer to a long-standing open question posed by Suffridge concerning the iterated application of the Δ_λ -operator to polynomials in $\mathcal{P}_n(\lambda)$. For the proofs of these results we will need some facts concerning Blaschke products and self-inversive convolution operators that might be of independent interest. Many of the results that we will present can also be found in [Lam10].

4.1. Some Results Concerning Blaschke Products and Self-Inversive Convolution Operators

In this section we will present definitions and results concerning Blaschke products and self-inversive convolution operators that will be needed in order to prove the main results of this chapter.

A *Blaschke product of degree $n \in \mathbb{N}$* is a rational function B of the form

$$B(z) = c \prod_{j=1}^n \frac{z + \zeta_j}{1 + \overline{\zeta_j} z}$$

with $|\zeta_j| < 1$ for $j = 1, \dots, n$ and $|c| = 1$. The notions of Blaschke product and inverse are closely connected: from the definition of the inverse of a polynomial it is clear that B is a Blaschke product of degree n if, and only if,

$$B = c \frac{P}{P^*},$$

where $|c| = 1$ and P is a polynomial of degree $m \geq n$ that has n zeros in the open unit disk and $m - n$ zeros on the unit circle. Note that if $P \in \mathcal{P}_n(0)$, then B as defined above is equal to a constant of modulus 1. For our considerations involving Blaschke products we shall need the following algebraic properties of the inverse: for two polynomials P and Q of degree n and $c \in \mathbb{T}$ one has

$$(P * Q)^* = P^* * Q^* \quad \text{and} \quad (P(cz))^* = \overline{c}^n P^*(cz),$$

while for P of degree n and Q of degree m

$$(P \cdot Q)^* = P^* \cdot Q^*.$$

These relations are easily verified and will be used frequently in the rest of the chapter without further mention.

In the next lemma some elementary properties of Blaschke products are collected.

LEMMA 4.9. *A rational function B is a Blaschke product if, and only if, $B(z)$ takes values on \mathbb{T} exactly for $z \in \mathbb{T}$ and $|B(z)| < 1$ for at least one $z \in \mathbb{D}$. If B is a Blaschke product of degree n , then for all $\zeta \in \mathbb{T}$ the equation $B(z) = \zeta$ has exactly n distinct solutions on the unit circle.*

PROOF. It is explained in [DGM02] that a Blaschke product of degree n takes each value on \mathbb{T} at n distinct points on \mathbb{T} . Since a rational function of degree n can take no value more than n times and since $|B(0)| < 1$ for every Blaschke product B , only the 'if'-direction of the first statement remains to be verified.

To this end, observe that if $B(z) \in \mathbb{T}$ only for $z \in \mathbb{T}$ and $|B(z)| < 1$ for one $z \in \mathbb{D}$, then $|B(z)| < 1$ for all $|z| < 1$. For otherwise there would be a $|w| < 1$ with $|B(w)| > 1$ and therefore the image under B of the straight line that connects z and w in \mathbb{D} would cross the unit circle. But this can not happen, since the pre-images under B of this crossing point would have to lie on the unit circle. Hence, since it is explained in [SS02, Sec. 7.2.2] that a rational function B , which satisfies $|B(z)| = 1$ and $|B(z)| < 1$ for $|z| = 1$ and $|z| < 1$, respectively, has to be a Blaschke product, the proof of the lemma is complete. \square

For a polynomial $p(z) = \sum_{k=0}^n a_k z^k$ of degree n we set

$$\delta[p](z) := \frac{p(z) - p(0)}{z} = \sum_{k=0}^{n-1} a_{k+1} z^k.$$

Then it is easy to see that

$$\Delta_\lambda[p * Q_n(\lambda; z)] = \delta[p] * Q_{n-1}(\lambda; z) \quad (4.4)$$

for $\lambda \in [0, \frac{2\pi}{n})$ and every polynomial p of degree n . We will use this fact frequently in the rest of the chapter without necessarily referring to it. Relation (4.4) leads to a way of defining the class $\mathcal{S}_n(\frac{2\pi}{n})$: by Theorem 4.8 and (4.4) a function $p \in \mathcal{S}_n^1$ is in $\mathcal{S}_n(\lambda)$ for a $\lambda \in [0, \frac{2\pi}{n})$ if all zeros of $\delta[p] * Q_{n-1}(\lambda; z)$ lie in the closed unit disk. Since

$$Q_{n-1}\left(\frac{2\pi}{n}; z\right) = \frac{1 - z^n}{1 - z} = \sum_{k=0}^{n-1} z^k = e_{n-1}(z), \quad (4.5)$$

one therefore defines the class $\mathcal{S}_n(\frac{2\pi}{n})$ to be the set of all polynomials $p \in \mathcal{S}_n^1$ for which $\delta[p] = \delta[p] * e_{n-1}$ has all its zeros in the closed unit disk. It is shown in [Suf76, Lem. 2] and [SS02, Sec. 7.6.3] that this definition is equivalent to the one given in the introduction of this chapter.

The following general observation concerning the operator δ will prove important later on.

LEMMA 4.10. *Let $p \in \mathcal{S}_n^1$ and $Q \in \mathcal{S}_{n-1}^1$. If $|(\delta[p] * Q)(0)| < 1$ and if the zeros of $\delta[p] * Q$ do not lie symmetrical with respect to the unit circle, then the following statements are equivalent (the parentheses in one statement hold if, and only if, the parentheses in the other two statements also hold):*

- (1) *All zeros of $\delta[p] * Q$ lie in the closed unit disk (and are of modulus < 1).*
- (2) *For all $\zeta \in \mathbb{T}$ all zeros of*

$$p * (1 + \zeta z)Q$$

(are simple and) lie on \mathbb{T} .

- (3) *For all $\zeta \in \mathbb{T}$ all zeros of*

$$(\delta[p]^* + \zeta \delta[p]) * Q$$

(are simple and) lie on \mathbb{T} .

PROOF. Set $C := (\delta[p]^* + \zeta \delta[p]) * Q$. Then

$$C = (\delta[p] * Q)^* + \zeta (\delta[p] * Q). \quad (4.6)$$

Because of our hypothesis the rational function

$$B := \frac{(\delta[p] * Q)}{(\delta[p] * Q)^*}$$

is not equal to a constant and therefore for all $\zeta \in \mathbb{T}$ all $n - 1$ zeros of C lie on \mathbb{T} if, and only if, B takes values on \mathbb{T} exactly for $z \in \mathbb{T}$. Since by our hypothesis also $|B(0)| < 1$, Lemma 4.9 shows that this holds if, and only if, B is a Blaschke product. This is equivalent to the fact that $\delta[p] * Q$ has all its zeros in the closed unit disk and to the fact that zB is a Blaschke product. Lemma 4.9 implies that the latter statement holds if, and only if, for all $\zeta \in \mathbb{T}$ all solutions of $zB(z) = -\bar{\zeta}$ or, equivalently,

$$\begin{aligned} 0 &= (\delta[p] * Q)^* + \zeta z (\delta[p] * Q) \\ &= \delta[p]^* * Q + (z\delta[p]) * (\zeta z Q) \\ &= p * Q + p * \zeta z Q = p * (1 + \zeta z)Q \end{aligned}$$

lie on \mathbb{T} . We have thus shown the equivalence of statements (1)–(3) without the parentheses.

The polynomial $\delta[p] * Q$ has all its zeros in the open unit disk, if and only if, B and zB are Blaschke products of degree $n - 1$ and n , respectively. Since a Blaschke product of degree n takes each value on \mathbb{T} at exactly n distinct points on \mathbb{T} , statements (1)–(3) are also equivalent if the parentheses are included. \square

The continuity theorem for polynomials will be essential for dealing with self-inversive convolution operators. For a proof we refer to [RS02, Sec. 1.3].

THEOREM 4.11 (Continuity theorem (CT)). *Let*

$$P(z) = a \prod_{j=1}^n (z - z_j) \quad \text{and} \quad P_k(z) = a_k \prod_{j=1}^n (z - z_{j,k}), \quad k \in \mathbb{N},$$

be polynomials of degree n . Then $P_k \rightarrow P$ (in \mathbb{C}^{n+1}) as $k \rightarrow \infty$ if, and only if, $a_k \rightarrow a$ as $k \rightarrow \infty$ and there is a sequence $\{\pi_k\}_{k \in \mathbb{N}}$ of permutations of $\{1, \dots, n\}$ such that $z_{\pi_k(j),k} \rightarrow z_j$, $j = 1, \dots, n$, as $k \rightarrow \infty$.

Because of coefficient symmetry it is clear that \mathcal{S}_n^1 is closed in \mathcal{P}_n . Since all zeros of a polynomial $P \in \mathcal{P}_n(\lambda)$, $\lambda \in [0, \frac{2\pi}{n}]$, lie on the unit circle (and since $P(0) = 1$), for $k \in \{0, \dots, n\}$ the k th coefficient of P has to be smaller than $\binom{n}{k}$. Therefore, since it follows readily from CT that $\mathcal{P}_n(\lambda)$ is closed, for all $\lambda \in [0, \frac{2\pi}{n}]$ the sets $\mathcal{P}_n(\lambda)$ and $\mathcal{S}_n(\lambda)$ are compact. CT shows that a polynomial $P \in \mathcal{P}_n(\lambda)$ is an *interior point* of $\mathcal{P}_n(\lambda)$ in \mathcal{S}_n^1 if, and only if, each pair of zeros of P is separated by an angle $> \lambda$. We shall say that a polynomial $P \in \mathcal{P}_n(\lambda)$ lies on a *one-dimensional boundary component* of $\mathcal{P}_n(\lambda)$ if

$$P(z) = Q_{n-k}(\lambda; e^{ik\alpha} e^{2ij\pi/n} z) Q_k(\lambda; e^{-i(n-k)\alpha} e^{2ij\pi/n} z),$$

where $k \in \{1, \dots, n - 1\}$, $j \in \{0, \dots, n - 1\}$ and $\alpha \in [\frac{\lambda}{2}, \frac{2\pi}{n} - \frac{\lambda}{2}]$. In other words, $P \in \mathcal{P}_n(\lambda)$ lies on a one-dimensional boundary component of $\mathcal{P}_n(\lambda)$ if, and only if, it has at most two pairs of consecutive zeros that are separated by an angle $> \lambda$.

If $H \in \mathcal{S}_n^1$ and $H \neq 1 + z^n$, then we call

$$\Phi : \mathcal{P}_n \rightarrow \mathcal{P}_n, P \mapsto H * P$$

a *self-inversive convolution operator of degree n* . Each self-inversive convolution operator Φ is a continuous mapping of the set \mathcal{S}_n^1 into itself. If $\lambda \in [0, \frac{2\pi}{n})$ and if there is a $\mu \in [0, \frac{2\pi}{n})$ such that

$$\Phi[\mathcal{P}_n(\lambda)] \subseteq \mathcal{P}_n(\mu)$$

we define $\mu(\Phi; \lambda)$ to be the largest $\mu \in [0, \frac{2\pi}{n})$ for which this relation holds. Then, since (a) with $\mathcal{P}_n(\lambda)$ also $\Phi[\mathcal{P}_n(\lambda)]$ is compact, (b) $\mathcal{P}_n(\mu)$ is a decreasing (with respect to μ) family of compact sets, and (c) obviously

$$\mathcal{P}_n(\mu) = \overline{\bigcup_{\mu < \lambda \leq \frac{2\pi}{n}} \mathcal{P}_n(\lambda)} = \overline{\bigcap_{0 \leq \lambda < \mu} \mathcal{P}_n(\lambda)}, \quad (4.7)$$

$\mu(\Phi; \lambda)$ is well defined and there is a polynomial $P \in \mathcal{P}_n(\lambda)$ for which $\Phi[P]$ has a pair of zeros that is separated by an angle of exactly $\mu(\Phi; \lambda)$ (if $\mu(\Phi; \lambda) = 0$ this means that $\Phi[P]$ has at least one multiple zero on \mathbb{T}). In such a case we will say that P is a *minimizing polynomial* for the self-inversive convolution operator Φ .

In [Lam05] Suffridge's proof of Theorem 4.4 is presented in a more elaborate way than the one in [Suf76]. In [Lam05] the central result in Suffridge's polynomial convolution theory takes the following form.

THEOREM 4.12 (cf. [Lam05, Thm. 4.8]). *Let $\lambda \in (0, \frac{2\pi}{n})$ and suppose that Φ is a self-inversive convolution operator on \mathcal{P}_n for which $\mu(\Phi; \lambda) > 0$. Then there is a minimizing polynomial for Φ that lies on a one-dimensional boundary component of $\mathcal{P}_n(\lambda)$.*

We shall need the following weak form of this theorem in the case that $\mu(\Phi; \lambda) = 0$.

LEMMA 4.13. *Let $\lambda \in [0, \frac{2\pi}{n})$ and suppose $\mu(\Phi; \lambda) = 0$ for a self-inversive convolution operator Φ of degree n . Then Φ maps the interior of $\mathcal{P}_n(\lambda)$ into the interior of $\mathcal{P}_n(0)$.*

PROOF. Let $\Phi[P] = H * P$ with $H(z) = \sum_{k=0}^n H_k z^k \in \mathcal{S}_n^1$. In order to obtain a contradiction, suppose that $P(z) = \sum_{k=0}^n A_k z^k$ is an interior point of $\mathcal{P}_n(\lambda)$ for which

$$C(z) := (H * P)(z) = \sum_{k=0}^n A_k H_k z^k$$

has a zero of order $l \in \{2, \dots, n\}$ at $z^* \in \mathbb{T}$. Then $C^{(l-1)}(z^*) = 0$ and therefore there has to be a maximal $p \in \{l-1, \dots, n-1\}$ for which $H_p \neq 0$. Because of coefficient symmetry and because p is chosen maximally, $p \geq \frac{n}{2}$.

Assume first that $p > \frac{n}{2}$ and set

$$P_{r,\theta}(z) := P(z) + r e^{-i\theta} z^{n-p} + r e^{i\theta} z^p$$

and

$$C_{r,\theta}(z) := (H * P_{r,\theta})(z) = C(z) + r e^{-i\theta} \overline{H_p} z^{n-p} + r e^{i\theta} H_p z^p$$

for $r, \theta \in \mathbb{R}$. Since P is an interior point of $\mathcal{P}_n(\lambda)$ there is an $r_0 > 0$ such that $P_{r,\theta} \in \mathcal{P}_n(\lambda)$, and thus $C_{r,\theta} \in \mathcal{P}_n(0)$, for all $r \in [0, r_0]$ and $\theta \in \mathbb{R}$. In particular, a repeated application of the theorem of Gauß-Lucas shows that for those r and θ all zeros of $C_{r,\theta}^{(l-1)}$ have to lie in the closed unit disk.

Fix $\theta \in \mathbb{R}$ and observe that since z^* is a zero of order l of C we have $C^{(l)}(z^*) = C_{0,\theta}^{(l)}(z^*) \neq 0$. Hence, by the implicit function theorem there is a differentiable function $z^*(r) \in \mathbb{C}$, r in a real neighborhood N of the origin, satisfying $z^* = z^*(0)$ and $C_{r,\theta}^{(l-1)}(z^*(r)) = 0$ for $r \in N$, such that

$$(z^*)'(0) = \frac{e^{-i\theta} A + e^{i\theta} B}{C^{(l)}(z^*(0))},$$

where

$$\begin{aligned} A &:= (-1)^l (p-n)_{l-1} \overline{H_p} z^*(0)^{n-p-(l-1)}, \\ B &:= (-1)^l (-p)_{l-1} H_p z^*(0)^{p-(l-1)}. \end{aligned}$$

Since $l-1 \leq p$ and $p > \frac{n}{2}$ we have $|B| > |A|$. Therefore

$$\arg(e^{-i\theta} A + e^{i\theta} B) = -\theta + \arg(A + e^{2i\theta} B)$$

increases by 2π if θ increases by 2π and thus there must be a $\theta^* \in \mathbb{R}$ such that $(z^*)'(0)$ and $z^*(0)$ have the same argument. This implies that $C_{r,\theta^*}^{(l-1)}$ has a zero outside $\overline{\mathbb{D}}$ for small $r > 0$ – a contradiction.

What remains now is to consider the case in which n is even and $p = \frac{n}{2}$. Then $H_p, A_p \in \mathbb{R}$ and $H(z) = 1 + H_p z^p + z^{2p}$ so that

$$C(z) = 1 + A_p H_p z^p + z^{2p}.$$

It is not difficult to check that a polynomial of the form $1 + Rz^p + z^{2p}$ has all its zeros on \mathbb{T} if, and only if, $R \in [-2, 2]$, and multiple zeros on \mathbb{T} if, and only if, $R \in \{-2, 2\}$. Since by our assumption C has at least one multiple zero on \mathbb{T} , $|A_p H_p| = 2$ has to hold. Since P is an interior point of $\mathcal{P}_n(\lambda)$ there is a real neighborhood N of the origin such that for $r \in N$

$$P_r(z) := P(z) + rz^p \in \mathcal{P}_n(\lambda)$$

and therefore

$$C_r(z) := (H * P_r)(z) = 1 + (A_p + r)H_p z^p + z^{2p} \in \mathcal{P}_n(0).$$

However, since $|A_p H_p| = 2$, we can find an $r^* \in N$ for which $|(A_p + r^*)H_p| > 2$. Hence, C_{r^*} has to have zeros off the unit circle – a contradiction. \square

This result can be used to show a refined version of Grace's theorem and an extension of Theorem 4.12 to the case where $\mu(\Phi; \lambda) = 0$.

LEMMA 4.14. *Let H lie in the interior of $\mathcal{P}_n(0)$ and define the self-inversive convolution operator Φ by $\Phi[P] := H *_0 P$ for $P \in \mathcal{S}_n^1$. Then $\mu(\Phi; 0) > 0$.*

PROOF. Because of Grace's theorem we have $\mu(\Phi; 0) \geq 0$.

Suppose $\mu(\Phi; 0) = 0$. Then there is a minimizing polynomial $P \in \mathcal{P}_n(0)$ such that $\Phi[P] = H *_0 P$ has a multiple zero on \mathbb{T} . A second application of Grace's theorem yields that for the self-inversive convolution operator $\Psi[Q] := P *_0 Q$, $Q \in \mathcal{S}_n^1$, we also have $\mu(\Psi; 0) = 0$. But then, by Lemma 4.13, $\Psi[H] = P *_0 H = \Phi[P]$ can not have a multiple zero on \mathbb{T} , since H lies in the interior of $\mathcal{P}_n(0)$. \square

THEOREM 4.15. *Let $\lambda \in (0, \frac{2\pi}{n})$ and suppose that Φ is a self-inversive convolution operator on \mathcal{P}_n for which $\mu(\Phi; \lambda) \geq 0$. Then there is a minimizing polynomial for Φ that lies on a one-dimensional boundary component of $\mathcal{P}_n(\lambda)$.*

PROOF. Because of Theorem 4.12 we have only to consider the case $\mu := \mu(\Phi; \lambda) = 0$.

Suppose $F \in \mathcal{P}_n(\lambda)$ is a minimizing polynomial for Φ , i.e. suppose F is such that $\Phi[F]$ has at least one multiple zero on \mathbb{T} , and let $\{\lambda_k\}_{k \in \mathbb{N}} \subset (\lambda, \frac{2\pi}{n})$ be such that $\lambda_k \rightarrow \lambda$ as $k \rightarrow \infty$. Then, by Lemma 4.13, we have $\mu_k := \mu(\Phi, \lambda_k) > 0$ for all $k \in \mathbb{N}$. Since by (4.7) there are polynomials $F_k \in \mathcal{P}_n(\lambda_k)$, $k \in \mathbb{N}$, such that $F_k \rightarrow F$ (and thus also $\Phi[F_k] \rightarrow \Phi[F]$) as $k \rightarrow \infty$, it follows from CT that $\mu_k \rightarrow 0$ as $k \rightarrow \infty$. By Theorem 4.12 to each $k \in \mathbb{N}$ there is a polynomial P_k lying on a one-dimensional boundary component of $\mathcal{P}_n(\lambda_k)$ for which $\Phi[P_k]$ has a pair of zeros separated by an angle of exactly μ_k . Because of the compactness of $\mathcal{P}_n(0)$ we may assume that there is a $P \in \mathcal{P}_n(0)$ such that $P_k \rightarrow P$ as $k \rightarrow \infty$ and because of CT P lies on a one-dimensional boundary component of $\mathcal{P}_n(\lambda)$. CT and the fact that $\mu_k \rightarrow 0$ as $k \rightarrow \infty$ imply that $\Phi[P]$ belongs to $\mathcal{P}_n(0)$ and has at least one multiple zero. \square

Let $H(z) = \sum_{k=0}^n A_k z^k$ be a polynomial of degree n whose zeros lie symmetrical with respect to the unit circle. Then there is a $c \in \mathbb{T}$ such that cH is self-inversive and therefore $cA_k = \overline{cA_{n-k}}$ for $k \in \{0, \dots, n\}$. It follows that

$$\hat{H}(z) := \frac{1}{A_0} H(dz) \quad \text{with} \quad d := \left(c \frac{A_0}{|A_0|} \right)^{\frac{2}{n}}$$

is a member of \mathcal{S}_n^1 . From now on we will use the following convention: If for an H as above we define a convolution operator Φ by

$$\Phi[P](z) := (H * P)(z), \quad P \in \mathcal{S}_n^1,$$

and call Φ a self-inversive convolution operator, it should always be understood that Φ is actually defined by

$$\Phi[P](z) := (\hat{H} * P)(z), \quad P \in \mathcal{S}_n^1.$$

Since $(\hat{H} * P)(z) = \frac{1}{A_0}(H * P)(dz)$, $\hat{H} * P$ is an element (resp. an interior point) of $\mathcal{P}_n(\lambda)$ for a $\lambda \in [0, \frac{2\pi}{n}]$ if, and only if $H * P$ has all its zeros on the unit circle and each pair of zeros of $H * P$ is separated by an angle $\geq \lambda$ (resp. $> \lambda$).

4.2. An Extension of Suffridge's Inclusion Theorem

In this section we will present and prove the main result of this chapter: an extension of Suffridge's inclusion theorem 4.3 (2).

Applying the definition of the classes $\mathcal{S}_n(\lambda)$, Theorem 4.3 (2) implies that if $P(z) = \sum_{k=0}^n \binom{n}{k}_\lambda a_k z^k$ belongs to $\mathcal{P}_n(\lambda)$ and $0 \leq \lambda \leq \mu < \frac{2\pi}{n}$, then

$$P *_\lambda Q_n(\mu; z) = \sum_{k=0}^n \binom{n}{k}_\mu a_k z^k \in \mathcal{P}_n(\mu).$$

Because of Theorem 4.8 this is equivalent to the fact that all zeros of

$$\Delta_\mu [P *_\lambda Q_n(\mu; z)](z) = \sum_{k=0}^{n-1} \binom{n-1}{k}_\mu a_{k+1} z^k = \Delta_\lambda [P] *_\lambda Q_{n-1}(\mu; z)$$

lie in the closed unit disk.

Suffridge's inclusion theorem 4.3 (2) can thus be stated in the following (nearly) equivalent form.

THEOREM 4.16 (Suffridge's inclusion theorem). *If $0 \leq \lambda \leq \mu < \frac{2\pi}{n}$ and if $P \in \mathcal{P}_n(\lambda)$, then all zeros of*

$$\Delta_\lambda [P] *_\lambda Q_{n-1}(\mu; z)$$

lie in the closed unit disk.

In this section we will prove the following extension of this result.

THEOREM 4.17. *Let $\lambda \in [0, \frac{2\pi}{n})$ and $P \in \mathcal{P}_n(\lambda)$, $Q \in \mathcal{P}_{n-1}(\lambda)$.*

- (1) *All zeros of $\Delta_\lambda [P] *_\lambda Q$ lie in the closed unit disk.*
- (2) *For all $\zeta \in \mathbb{T}$ all zeros of*

$$P *_\lambda (1 + z\zeta)Q$$

lie on \mathbb{T} .

- (3) *If P is not a rotation of $Q_n(\lambda; z)$, then for all $\zeta \in \mathbb{T}$ all zeros of*

$$(\Delta_\lambda [P]^* + \zeta \Delta_\lambda [P]) *_\lambda Q$$

lie on \mathbb{T} .

The statements (1)–(3) are equivalent.

The equivalence of the three statements is shown in the next lemma.

LEMMA 4.18. *Let $\lambda \in [0, \frac{2\pi}{n})$ and suppose $P \in \mathcal{P}_n(\lambda)$ and $Q \in \mathcal{P}_{n-1}(\lambda)$. If P is not a rotation of the extremal polynomial $Q_n(\lambda; z)$, then the following statements are equivalent (the parentheses in one statement hold if, and only if, the parentheses in the other two statements also hold):*

- (1) *All zeros of $\Delta_\lambda [P] *_\lambda Q$ lie in the closed unit disk (and are of modulus < 1).*

(2) For all $\zeta \in \mathbb{T}$ all zeros of

$$P *_{\lambda} (1 + \zeta z)Q$$

(are simple and) lie on \mathbb{T} .

(3) For all $\zeta \in \mathbb{T}$ all zeros of

$$(\Delta_{\lambda}[P]^* + \zeta \Delta_{\lambda}[P]) *_{\lambda} Q$$

(are simple and) lie on \mathbb{T} .

PROOF. Let $p \in \mathcal{S}_n(\lambda)$ be such that $P = p * Q_n(\lambda; z)$. We have

$$\Delta_{\lambda}[P] *_{\lambda} Q = \delta[p] * Q, \quad P *_{\lambda} (1 + \zeta z)Q = p * (1 + \zeta z)Q, \quad (4.8)$$

and

$$(\Delta_{\lambda}[P]^* + \zeta \Delta_{\lambda}[P]) *_{\lambda} Q = (\delta[p]^* + \zeta \delta[p]) * Q. \quad (4.9)$$

Our claim will therefore follow from Lemma 4.10 once it is verified that $|(\Delta_{\lambda}[P] *_{\lambda} Q)(0)| < 1$ and that the zeros of $\Delta_{\lambda}[P] *_{\lambda} Q$ do not lie symmetrical with respect to \mathbb{T} .

In order to do this, let $P(z) = \sum_{k=0}^n \binom{n}{k}_{\lambda} a_k z^k$ and $Q(z) = \sum_{k=0}^{n-1} \binom{n-1}{k}_{\lambda} b_k z^k$ and suppose that the zeros of

$$C(z) := (\Delta_{\lambda}[P] *_{\lambda} Q)(z) = \sum_{k=0}^{n-1} \binom{n-1}{k}_{\lambda} a_{k+1} b_k z^k$$

lie symmetrical with respect to \mathbb{T} . Then there is a $c \in \mathbb{T}$ such that cC is self-inversive. Hence, $ca_{k+1}b_k = \overline{ca_{n-k}b_{n-1-k}}$ for $k \in \{0, \dots, n-1\}$ and consequently, as $b_0 = b_{n-1} = a_n = 1$, $|a_1| = 1$. a_1 is the constant coefficient of $\Delta_{\lambda}[P]$, a polynomial with leading coefficient 1 that by Theorem 4.8 has all its zeros in \mathbb{D} . Therefore all zeros of $\Delta_{\lambda}[P]$ have to lie on \mathbb{T} and Theorem 4.8 shows that this happens if, and only if, P is a rotation of $Q_n(\lambda; z)$.

Since $C(0) = a_1$, we also get $|C(0)| \leq 1$ for all $P \in \mathcal{P}_n(\lambda)$ with $|C(0)| = 1$ if, and only if, P is a rotation of $Q_n(\lambda; z)$. \square

Note that the convolution factors in the statements (2) and (3) of the above lemma are of degree n and $n-1$, respectively. The next lemma will be important for exploiting the equivalence of those two statements in order to obtain a proof by induction of Theorem 4.17.

LEMMA 4.19. *Let P lie on a one-dimensional boundary component of $\mathcal{P}_n(\lambda)$. If P is not a rotation of $Q_n(\lambda; z)$, then there is a polynomial $R \in \mathcal{P}_{n-2}(\lambda)$ and a $c \in \mathbb{T}$ such that for every $\zeta \in \mathbb{T}$ there are $\eta \in \mathbb{T}$ and $\gamma \in \mathbb{C} \setminus \{0\}$ with*

$$\Delta_{\lambda}[P]^*(z) + \zeta \Delta_{\lambda}[P](z) = \gamma(1 + \eta z)R(cz).$$

PROOF. Because P lies on a one-dimensional boundary component of $\mathcal{P}_n(\lambda)$, there are $n_1, n_2 \in \mathbb{N}$ with $n_1 + n_2 = n$ and $\alpha_1, \alpha_2 \in \mathbb{R}$ with $n_1\alpha_1 + n_2\alpha_2 = 2k\pi$ for an integer k such that

$$P(z) = Q_{n_1}(\lambda; e^{i\alpha_1}z)Q_{n_2}(\lambda; e^{i\alpha_2}z).$$

Since P is not a rotation of $Q_n(\lambda; z)$, it follows from Theorem 4.8 that there is a $w \in \mathbb{D}$ such that

$$\Delta_{\lambda}[P](z) = (dz - w)Q_{n_1-1}(\lambda; e^{i\alpha_1}z)Q_{n_2-1}(\lambda; e^{i\alpha_2}z),$$

where $d := e^{i(\alpha_1 + \alpha_2)}$ (the leading coefficient of $\Delta_{\lambda}[P]$ must be 1). Set

$$c := e^{-i(\alpha_1 + \alpha_2)/(n_1 + n_2 - 2)} \quad \text{and} \quad R(z) := Q_{n_1-1}(\lambda; e^{i\alpha_1}\bar{c}z)Q_{n_2-1}(\lambda; e^{i\alpha_2}\bar{c}z).$$

Then $\Delta_\lambda[P](z) = (dz - w)R(cz)$ and $R \in \mathcal{P}_{n-2}(\lambda)$, since R has the right normalization and each pair of zeros of R is separated by an angle $\geq \lambda$. Therefore

$$\Delta_\lambda[P]^*(z) + \zeta \Delta_\lambda[P](z) = (\bar{c}^{n-2}\bar{d} - \zeta w + (\zeta d - \bar{c}^{n-2}\bar{w})z)R(cz).$$

Our assertion follows by setting

$$\gamma := \bar{c}^{n-2}\bar{d} - \zeta w \quad \text{and} \quad \eta := \zeta c^{n-2} \frac{\zeta d - \bar{c}^{n-2}\bar{w}}{\zeta \bar{d} - c^{n-2}w}.$$

□

We proceed to the proof of Theorem 4.17.

PROOF OF THEOREM 4.17. The case $\lambda = 0$ follows from the theorem of Grace.

In order to show the case $\lambda \in (0, \frac{2\pi}{n})$, we will apply Lemma 4.18 and prove by induction that if $P \in \mathcal{P}_n(\lambda)$ and $Q \in \mathcal{P}_{n-1}(\lambda)$, then for all $\zeta \in \mathbb{T}$ all zeros of

$$(1 + \zeta z)Q *_\lambda P \tag{4.10}$$

lie on the unit circle \mathbb{T} .

For $n = 1$ the assertion is trivially true.

Let $n > 1$, $\lambda \in (0, \frac{2\pi}{n})$ and $Q \in \mathcal{P}_{n-1}(\lambda)$ and suppose for the moment that $\zeta \in \mathbb{T}$ is such that $(1 + \zeta z)Q$ is not equal to $1 + z^n$ and has only simple zeros on \mathbb{T} . For $t \in [0, \lambda]$ define the self-inversive convolution operator Φ_t by

$$\Phi_t[P](z) := (1 + \zeta z)Q(z) *_t P(z), \quad P \in \mathcal{S}_n^1,$$

and set

$$\mu(t) := \mu(\Phi_t, t)$$

for all $t \in [0, \lambda]$ for which $\mu(\Phi_t, t)$ is defined.

Note first that each $t^* \in [0, \frac{2\pi}{n})$, for which $\mu(t^*)$ is positive, has a neighborhood N in $[0, \frac{2\pi}{n})$ such that $\mu(t) > 0$ for $t \in N$ (in the following we will call this the (p)-property of $\mu(t)$).

For otherwise there is a sequence $\{t_k\}_{k \in \mathbb{N}} \subset [0, \frac{2\pi}{n})$ that converges to t^* as $k \rightarrow \infty$ and polynomials $P_k \in \mathcal{P}_n(t_k)$ such that

$$\Phi_{t_k}[P_k] \notin \mathcal{P}_n(s) \quad \text{for all } k \in \mathbb{N}, s \in \left(0, \frac{2\pi}{n}\right]. \tag{4.11}$$

Since $\mathcal{P}_n(0)$ is compact, we may assume that there is a $P \in \mathcal{P}_n(0)$ such that $P_k \rightarrow P$ as $k \rightarrow \infty$, and because of CT we must have $P \in \mathcal{P}_n(t^*)$. Then $\Phi_{t_k}[P_k] \rightarrow \Phi_{t^*}[P]$ as $k \rightarrow \infty$, which, because of CT, contradicts (4.11).

Since $(1 + \zeta z)Q$ has only simple zeros, Lemma 4.14 gives $\mu(0) > 0$. Hence, because of the (p)-property of $\mu(t)$,

$$t^* := \sup\{t \in (0, \lambda] : \mu(s) > 0 \text{ for all } s \in [0, t]\}$$

is well defined. If $P \in \mathcal{P}_n(t^*)$, then $P \in \mathcal{P}_n(s)$ (and thus $\Phi_s[P] \in \mathcal{P}_n(0)$) for all $s \in [0, t^*)$. Hence, because of CT, we have $\mu(t^*) \geq 0$.

In order to obtain a contradiction we assume that $t^* < \lambda$. Then $\mu(t^*) = 0$ has to hold, since otherwise the (p)-property of $\mu(t)$ would contradict the definition of t^* , and, because of Theorem 4.15, there is a polynomial P lying on a one-dimensional boundary component of $\mathcal{P}_n(t^*)$ for which

$$\Phi_{t^*}[P] = (1 + \zeta z)Q *_t P$$

has a multiple zero on the unit circle. Since $(1 + \zeta z)Q$ has only simple zeros on \mathbb{T} , P can not be a rotation of the extremal polynomial $Q_n(t^*, z)$.

Because of Lemma 4.19 there is a polynomial $R \in \mathcal{P}_{n-2}(t^*)$ and a $c \in \mathbb{T}$ such that for all $\xi \in \mathbb{T}$ there are $\eta \in \mathbb{T}$ and $\gamma \in \mathbb{C} \setminus \{0\}$ with

$$\Delta_{t^*}[P]^*(z) + \xi \Delta_{t^*}[P](z) = \gamma(1 + \eta z)R(cz). \quad (4.12)$$

For $F \in \mathcal{S}_{n-1}^1$ define now

$$\Psi_\eta[F](z) := (1 + \eta z)R(cz) *_{t^*} F(z).$$

It follows from the induction hypothesis that $\mu(\Psi_\eta, t^*) \geq 0$ for all $\eta \in \mathbb{T}$.

Suppose that $\mu(\Psi_\eta, t^*) = 0$ for an $\eta \in \mathbb{T}$. Since $Q \in \mathcal{P}_{n-1}(\lambda)$ and $t^* < \lambda$, Q is an interior point of $\mathcal{P}_{n-1}(t^*)$ and therefore Lemma 4.13 shows that $\Psi_\eta[Q]$ has only simple zeros on \mathbb{T} . This, of course, holds also if $\mu(\Psi_\eta, t^*) > 0$ and thus for all $\eta \in \mathbb{T}$

$$(1 + \eta z)R(cz) *_{t^*} Q(z)$$

has only simple zeros on \mathbb{T} . Because of (4.12) this means that for all $\xi \in \mathbb{T}$

$$(\Delta_\lambda[P]^* + \xi \Delta_\lambda[P]) *_{t^*} Q$$

has only simple zeros on \mathbb{T} . By Lemma 4.18 this is equivalent to the fact that for all $\xi \in \mathbb{T}$

$$(1 + \xi z)Q *_{t^*} P$$

has only simple zeros on \mathbb{T} . Since this holds in particular for $\xi = \zeta$, we have obtained a contradiction. Thus $t^* = \lambda$ must be true and therefore

$$\mu(\lambda) = \mu(t^*) \geq 0.$$

Finally, let $Z \subset \mathbb{T}$ be the set of those $\zeta \in \mathbb{T}$ for which $(1 + \zeta z)Q$ either has a multiple zero on \mathbb{T} or is equal to $1 + z^n$. Then Z contains at most n elements and therefore for each $\zeta \in Z$ the polynomial

$$(1 + \zeta z)Q *_{\lambda} P$$

can be approximated by a sequence

$$(1 + \zeta_k z)Q *_{\lambda} P, \quad k \in \mathbb{N},$$

with $\zeta_k \in \mathbb{T} \setminus Z$. It follows from CT and what we have shown above that $(1 + \zeta z)Q *_{\lambda} P \in \mathcal{P}_n(0)$. \square

Theorem 4.17 can be extended to $\lambda = \frac{2\pi}{n}$. In order to do this, we need the relation

$$\mathcal{S}_n\left(\frac{2\pi}{n}\right) = \overline{\bigcup_{0 \leq \lambda < \frac{2\pi}{n}} \mathcal{S}_n(\lambda)}, \quad (4.13)$$

which is proven in [Suf76] (see also [Lam05, Sec. 4.3]).

THEOREM 4.20. *Let $\lambda \in [0, \frac{2\pi}{n}]$ and $p \in \mathcal{S}_n(\lambda)$, $Q \in \mathcal{P}_{n-1}(\lambda)$.*

- (1) *All zeros of $\delta[p] * Q$ lie in the closed unit disk.*
- (2) *For all $\zeta \in \mathbb{T}$ all zeros of*

$$p * (1 + z\zeta)Q$$

lie on \mathbb{T} .

- (3) *If p is not equal to a rotation of $e_n(z) = 1 + z + \cdots + z^n$, then for all $\zeta \in \mathbb{T}$ all zeros of*

$$(\delta[p]^* + \zeta \delta[p]) * Q$$

lie on \mathbb{T} .

PROOF. For $\lambda \in [0, \frac{2\pi}{n})$ and $p \in \mathcal{S}_n(\lambda)$ the assertion follows from Theorem 4.17 and (4.8), (4.9). Since $Q \in \mathcal{P}_{n-1}(\frac{2\pi}{n})$ implies $Q \in \mathcal{P}_{n-1}(\lambda)$ for all $\lambda \in [0, \frac{2\pi}{n})$, this also shows that for all $\lambda \in [0, \frac{2\pi}{n})$, $p \in \mathcal{S}_n(\lambda)$ and all $Q \in \mathcal{P}_{n-1}(\frac{2\pi}{n})$ all zeros of $\delta[p] * Q$ lie in $\overline{\mathbb{D}}$. Statement (1) thus follows from CT and (4.13).

The case $\lambda = \frac{2\pi}{n}$ of statements (2) and (3) will now be proven by an application of Lemma 4.10. To this end, we have to show that if $Q \in \mathcal{P}_{n-1}(\frac{2\pi}{n})$ and $p(z) = \sum_{k=0}^n a_k z^k \in \mathcal{S}_n(\frac{2\pi}{n})$ is not a rotation of $e_n(z)$, then $|(\delta[p] * Q)(0)| < 1$ and the zeros of $\delta[p] * Q$ do not lie symmetric to the unit circle. As in the proof of Lemma 4.18 one can see that this holds if $|a_1| < 1$.

By (4.2) there are $c_1, \dots, c_n \geq 0$ with $\sum_{k=1}^n c_k = 1$ such that

$$p(z) = \sum_{k=1}^n c_k e_n(e^{2\pi i k/n} z).$$

In particular, a_1 lies in the convex hull of the n th roots of unity and therefore we have $|a_1| \leq 1$ with $|a_1| = 1$ if, and only if, p is a rotation of e_n . \square

One particular consequence of this theorem is that if $\lambda \in [0, \frac{2\pi}{n}]$ and if $p \in \mathcal{S}_n(\lambda)$ is not a rotation of e_n , then for every $\zeta \in \mathbb{T}$ the self-inversive convolution operator

$$\Phi_\zeta[P] := (\delta[p]^* + \zeta \delta[p]) * P, \quad P \in \mathcal{S}_{n-1}^1,$$

satisfies $\mu(\Phi_\zeta, \lambda) \geq 0$. Thus, if Q is an interior point of $\mathcal{P}_{n-1}(\lambda)$, then it follows from Lemma 4.13 that for all $\zeta \in \mathbb{T}$ the polynomial $(\delta[p]^* + \zeta \delta[p]) * Q$ has only simple zeros. By Lemma 4.10 this means that all zeros of $\delta[p] * Q$ lie in the open unit disk.

In the special case $Q = Q_{n-1}(\mu; z)$ with $\lambda < \mu \leq \frac{2\pi}{n}$ we obtain that all zeros of $\delta[p] * Q_{n-1}(\mu; z) = \Delta_\mu[p * Q_n(\mu; z)]$ lie in \mathbb{D} . By Theorem 4.8 this means that $p * Q_n(\mu; z)$ lies in the interior of $\mathcal{P}_n(\mu)$. Theorem 4.20 can thus be seen as a generalization of the fact that if $\lambda < \mu \leq \frac{2\pi}{n}$, then $\mathcal{S}_n(\lambda)$ is contained in the interior of $\mathcal{S}_n(\mu)$ (this is Suffridge's inclusion theorem 4.3 (2)).

Suffridge's inclusion theorem and (4.13) show that if p lies in the interior of $\mathcal{S}_n(\frac{2\pi}{n})$, then there has to be a $\lambda \in [0, \frac{2\pi}{n})$ such that $p \in \mathcal{S}_n(\lambda)$. Since every $Q \in \mathcal{P}_{n-1}(\frac{2\pi}{n})$ is contained in the interior of $\mathcal{P}_{n-1}(\lambda)$, it follows from what we have shown above that for these kinds of p and Q all zeros of $\delta[p] * Q$ lie in \mathbb{D} .

We obtain the following refinement of Theorem 4.20.

COROLLARY 4.21. *Let $\lambda \in [0, \frac{2\pi}{n}]$, $Q \in \mathcal{P}_{n-1}(\lambda)$ and $p \in \mathcal{S}_n(\lambda)$ with p not equal to a rotation of e_n . If p is an interior point of $\mathcal{S}_n(\lambda)$ or Q an interior point of $\mathcal{P}_{n-1}(\lambda)$, then all zeros of $\delta[p] * Q$ lie in the open unit disk.*

PROOF. The only case that remains to be verified is the one in which $\lambda \in [0, \frac{2\pi}{n})$, $Q \in \mathcal{P}_{n-1}(\lambda)$, and p lies in the interior $\mathcal{S}_n(\lambda)$.

Theorem 4.17 shows that for all $\zeta \in \mathbb{T}$ the self-inversive convolution operator

$$\Phi_\zeta[P] := (1 + \zeta z)Q *_\lambda P, \quad P \in \mathcal{S}_n^1,$$

satisfies $\mu(\Phi_\zeta, \lambda) \geq 0$. Since $P = p * Q_n(\lambda)$ is an interior point of $\mathcal{P}_n(\lambda)$, it follows from Lemma 4.13 that for all $\zeta \in \mathbb{T}$ all zeros of $(1 + \zeta z)Q *_\lambda P$ are simple. Because of Lemma 4.18 this means that all zeros of $\Delta_\lambda[P] *_\lambda Q = \delta[p] * Q$ lie in the open unit disk. \square

4.3. Laguerre's Theorem for the Classes $\mathcal{P}_n(\lambda)$

In this section we will show that there exists no proper extension of the theorem of Laguerre to the classes $\mathcal{P}_n(\lambda)$.

Statement (3) of Theorem 4.17 calls for a closer examination of the operator

$$\Delta_\lambda[P; \zeta] := \Delta_\lambda[P]^* + \zeta \Delta_\lambda[P]$$

which is defined for polynomials P of degree n , $\zeta \in \mathbb{C}$, and $\lambda \in [0, \frac{2\pi}{n})$. If $P \in \mathcal{S}_n$ and $\lambda \in (0, \frac{2\pi}{n})$, then

$$\begin{aligned} \Delta_\lambda[P]^*(z) &= z^{n-1} \overline{\Delta_\lambda[P] \left(\frac{1}{\bar{z}} \right)} = \frac{(P(e^{-i\lambda/2}z))^* - (P(e^{i\lambda/2}z))^*}{2i \sin \frac{n\lambda}{2}} \\ &= \frac{e^{in\lambda/2}P(e^{-i\lambda/2}z) - e^{-in\lambda/2}P(e^{i\lambda/2}z)}{2i \sin \frac{n\lambda}{2}} \\ &= P(e^{i\lambda/2}z) - e^{in\lambda/2}z \Delta_\lambda[P](z), \end{aligned} \quad (4.14)$$

and we thus obtain

$$\Delta_\lambda[P; \zeta](z) = P(e^{i\lambda/2}z) - (e^{in\lambda/2}z - \zeta) \Delta_\lambda[P](z)$$

for $P \in \mathcal{S}_n$, $\zeta \in \mathbb{C}$, and $\lambda \in [0, \frac{2\pi}{n})$ (the case $\lambda = 0$ follows from taking the limit $\lambda \rightarrow 0$).

If P is a polynomial of degree n and $\zeta \in \mathbb{C}$, then

$$P(z) - (z - \zeta) \frac{P'(z)}{n} = P(z) - (z - \zeta) \Delta_0[P](z)$$

is usually called the *polar derivative of P with respect to ζ* . The theorem of Laguerre gives some information about the zeros of polar derivatives (cf. [RS02, Ch. 3]).

THEOREM 4.22 (Laguerre). *Let P be a polynomial of degree n that has all its zeros in the closed unit disk. Then, if $|\zeta| \geq 1$, all zeros of*

$$P(z) - (z - \zeta) \frac{P'(z)}{n}$$

lie also in the closed unit disk unless $|\zeta| = 1$ and $P(z) = (z - \zeta)^n$.

Since

$$\frac{1}{\zeta} \left(P(z) - (z - \zeta) \frac{P'(z)}{n} \right) \rightarrow \frac{P'(z)}{n} \quad \text{as } \zeta \rightarrow \infty,$$

the theorem Laguerre can be seen as a generalization of the theorem of Gauß-Lucas. In the present context it is perhaps also interesting to note that Laguerre's theorem is one of the many equivalent formulations of Grace's theorem (cf. [RS02, Ch. 3] and [Lam05, Ch. 2]).

In a weak form the theorem of Laguerre holds also for the classes $\mathcal{P}_n(\lambda)$.

THEOREM 4.23. *Let $\lambda \in [0, \frac{2\pi}{n})$ and suppose $P \in \mathcal{P}_n(\lambda)$ is not a rotation of $Q_n(\lambda; z)$. Then for each $\zeta \in \mathbb{T}$ all zeros of $\Delta_\lambda[P; \zeta]$ lie on \mathbb{T} .*

PROOF. Set $Q = Q_{n-1}(\lambda; z)$ in Lemma 4.18 and use Theorem 4.8 and the equivalence between statements (1) and (3) of Lemma 4.18. \square

At this point we should also like to show how Lemma 4.18 can be used in order to obtain a direct proof (i.e. without resorting first to the theorem of Grace) of the case $\lambda = 0$ of Suffridge's convolution theorem 4.4.

THEOREM 4.24. *Let $P, Q \in \mathcal{P}_n(0)$. Then $P *_0 Q \in \mathcal{P}_n(0)$.*

PROOF. If $n = 1$ or P is equal to a rotation of $Q_n(0; z)$, then the assertion is clear.

Thus, let $n > 1$ and assume that P is not equal to a rotation of $Q_n(0; z)$. Suppose $-\bar{\eta}$ is a zero of Q and set $\hat{Q} := Q/(1 + \eta z)$. By Theorem 4.23 and the induction hypothesis for all $\zeta \in \mathbb{T}$ all zeros of $\Delta_0[P; \zeta] * \hat{Q}$ lie on \mathbb{T} . By Lemma 4.18 this happens if, and only if, for all $\zeta \in \mathbb{T}$ all zeros of $P * (1 + \zeta z)\hat{Q}$ lie on the unit circle. In particular, setting $\zeta = \eta$, it follows that $P * Q$ belongs to $\mathcal{P}_n(0)$. \square

It would be very useful to have more information about the location of the zeros of $\Delta_\lambda[P; \zeta]$ than the one given in Theorem 4.23. For instance, if Lemma 4.19 would hold for all $P \in \mathcal{P}_n(\lambda)$ (and not just for polynomials on one-dimensional boundary components of $\mathcal{P}_n(\lambda)$), then an easy adaption of the proof of Theorem 4.24 would give a proof of statement (2) of Theorem 4.17. Observe also that for $\lambda = 0$ Theorem 4.23 is somewhat of an invariance statement: if $P \in \mathcal{P}_n(0)$, then for all $\zeta \in \mathbb{T}$ also $\Delta_0[P; \zeta] \in \mathcal{P}_{n-1}(0)$ (up to normalization). It thus seems reasonable to ask if such an invariance also holds when $\lambda \in (0, \frac{2\pi}{n})$. It is not hard to see that in general the answer to this question is negative: a close look at the proof of Lemma 4.19 reveals that if $\lambda \in (0, \frac{2\pi}{n})$ and if P lies on a one-dimensional boundary component of $\mathcal{P}_n(\lambda)$ (P not equal to a rotation of $Q_n(\lambda; z)$), then there is at least one open connected subset T of \mathbb{T} such that, for all $\zeta \in T$, $\Delta_\lambda[P; \zeta]$ has a pair of zeros that is separated by an angle $< \lambda$. Nevertheless, one might assume that for each $P \in \mathcal{P}_n(\lambda)$ there are at least some $\zeta \in \mathbb{T}$ such that $\Delta_\lambda[P; \zeta] \in \mathcal{P}_n(\lambda)$ (up to normalization).

Our next theorem shows that the operator $P \mapsto \Delta_\lambda[P; \zeta]$ possesses neither of the suggested (or desired) properties.

THEOREM 4.25.

- (1) *If $n \geq 3$ and $\lambda \in (0, \frac{2\pi}{n})$, then for every $P \in \mathcal{P}_n(\lambda)$ that is not a rotation of $Q_n(\lambda; z)$ and all $\zeta \in \mathbb{T}$ there are $b \in \mathbb{C} \setminus \{0\}$, $c, d \in \mathbb{T}$, and $F \in \mathcal{P}_{n_1}(\lambda)$, $G \in \mathcal{P}_{n_2}(\lambda)$ with $n_1 + n_2 = n - 1$ such that*

$$\Delta_\lambda[P; \zeta](z) = b F(cz) G(dz).$$

- (2) *For all $n \geq 7$ and $\lambda \in (\frac{\pi}{n-3}, \frac{2\pi}{n})$ there is a polynomial $P \in \mathcal{P}_n(\lambda)$ such that for all $\zeta \in \mathbb{T}$ the polynomial $\Delta_\lambda[P; \zeta]$ has a pair of zeros on \mathbb{T} that is separated by an angle of less than λ .*
- (3) *For all $n \geq 7$ and $\lambda \in (\frac{\pi}{n-3}, \frac{2\pi}{n})$ there is a polynomial $P \in \mathcal{P}_n(\lambda)$ for which there is a $\zeta \in \mathbb{T}$ such that $\Delta_\lambda[P; \zeta]$ has at least two pairs of zeros on \mathbb{T} that are separated by an angle of less than λ .*

For the proof of this theorem we will first introduce some more terminology.

It is immediately clear that, for $\lambda \in [0, \frac{2\pi}{n})$, a polynomial P lies in $\mathcal{P}_n(\lambda)$ if, and only if, P can be written in the form

$$P(z) = \prod_{j=1}^m Q_{n_j}(\lambda; e^{i\alpha_j} z), \quad (4.15)$$

with $\sum_{j=1}^m n_j = n$, $\prod_{j=1}^m e^{in_j\alpha_j} = 1$, $\alpha_1 < \dots < \alpha_m < \alpha_{m+1} := \alpha_1 + 2\pi$ and

$$\alpha_{j+1} - \frac{n_{j+1}\lambda}{2} > \alpha_j + \frac{n_j\lambda}{2} \quad (4.16)$$

for $j = 1, \dots, m$ ($n_{m+1} := n_1$). The condition (4.16) ensures that each pair of zeros of the polynomial P given in (4.15) is separated by an angle of at least λ and that in the product the minimum number of factors is used (i.e. for $j \in \{1, \dots, m\}$ the polynomials $Q_{n_{j+1}}(\lambda; e^{i(\alpha_j \pm \lambda/2)} z)$ are not factors of P). The representation (4.15) is

therefore unique (up to shifts of the sequence $\{(n_j, \alpha_j)\}_{j=1}^m$) and will be called the *standard representation of P* .

If $P \in \mathcal{P}_n(\lambda)$ has the standard representation (4.15), then by Theorem 4.8 there is a polynomial Q of degree $m - 1$ that has all its zeros in \mathbb{D} such that

$$\Delta_\lambda[P](z) = Q(z) \prod_{j=1}^m Q_{n_j-1}(\lambda; e^{i\alpha_j} z).$$

Thus for $\zeta \in \mathbb{T}$

$$\Delta_\lambda[P; \zeta](z) = (e^{-ic} Q^*(z) + \zeta Q(z)) \prod_{j=1}^m Q_{n_j-1}(\lambda; e^{i\alpha_j} z),$$

where $c = \sum_{j=1}^m \alpha_j(n_j - 1)$. Therefore, for all $\zeta \in \mathbb{T}$, each zero of

$$\frac{\Delta_\lambda[P](z)}{Q(z)} = \prod_{j=1}^m Q_{n_j-1}(\lambda; e^{i\alpha_j} z)$$

is a zero of $\Delta_\lambda[P; \zeta]$. Since those $n - m$ zeros of $\Delta_\lambda[P; \zeta]$ do not depend on ζ we will call them the *independent zeros of $\Delta_\lambda[P; \zeta]$* . The other $m - 1$ zeros will be called the *dependent zeros of $\Delta_\lambda[P; \zeta]$* .

We need the following auxiliary result, which sharpens Sheil-Smith's interspersion theorem [SS02, pp. 235, 251] (see also [Lam05, Cor. 3.16]).

LEMMA 4.26. *Let $\lambda \in (0, \frac{2\pi}{n})$ and suppose $P \in \mathcal{P}_n(\lambda)$ has the standard representation (4.15). Set*

$$R(z) := e^{-in\lambda/2} \frac{P(e^{i\lambda/2} z)}{P(e^{-i\lambda/2} z)} = e^{-in\lambda/2} \prod_{j=1}^m \frac{1 + e^{i(\alpha_j + n_j\lambda/2)} z}{1 + e^{i(\alpha_j - n_j\lambda/2)} z} \quad (4.17)$$

and $T := (\frac{n_1\lambda}{2} - \alpha_1 - \pi, \frac{n_1\lambda}{2} - \alpha_1 + \pi]$. Then $r(t) := R(e^{it})$, $t \in T$, vanishes exactly at the points $z_j := \pi - \alpha_j - \frac{n_j\lambda}{2}$ and $|r(t)|$, $t \in T$, takes the value infinity exactly at the points $p_j := \pi - \alpha_j + \frac{n_j\lambda}{2}$ ($j \in \{1, \dots, m\}$). Moreover, for all $j \in \{1, \dots, m\}$ the function r is a decreasing homeomorphism between $T_j := (p_{j+1}, p_j)$ and \mathbb{R} .

PROOF. The fact that R takes the form as stated in (4.17) follows directly from (4.15) and the definition of the $Q_{n_j}(\lambda; e^{i\alpha_j} z)$.

Setting $z = e^{it}$ in (4.17), a straightforward computation shows that

$$r(t) = \prod_{j=1}^m \frac{\cos(\frac{t+\alpha_j}{2} + \frac{n_j\lambda}{4})}{\cos(\frac{t+\alpha_j}{2} - \frac{n_j\lambda}{4})}, \quad t \in T.$$

It follows from (4.16) that r vanishes exactly at the points z_j and has singularities exactly at the points p_j . In particular, since $p_{j+1} < z_j < p_j$ (this follows again from (4.16)), this means that r takes every real value at least once in each of the intervals T_j , $j \in \{1, \dots, m\}$. But R is a rational function of degree m and can thus take no value more than m times. Hence, r is injective in each of the intervals T_j . Finally, using (4.16) once more, it is straightforward to check that

$$\frac{\cos(\frac{t+\alpha_j}{2} + \frac{n_j\lambda}{4})}{\cos(\frac{t+\alpha_j}{2} - \frac{n_j\lambda}{4})}$$

is negative in T exactly for $t \in (z_j, p_j)$. Therefore r must be negative in each interval (z_j, p_j) , $j \in \{1, \dots, m\}$. \square

Essentially, the next lemma gives the proof of Theorem 4.25.

LEMMA 4.27. *Let $\lambda \in (0, \frac{2\pi}{n})$ and suppose $P \in \mathcal{P}_n(\lambda)$ has the standard representation (4.15).*

- (1) *Let $x \in \mathbb{R}$ and suppose P is not a rotation of $Q_n(\lambda; z)$. If $n \geq 4$ and $s_1 \leq s_2 \leq s_3 \leq s_1 + 2\pi$ are such that $\Delta_\lambda[P; e^{ix}](e^{is_k}) = 0$ for $k = 1, 2, 3$, then $s_3 - s_1 \geq \lambda$.*
- (2) *For $j \in \{1, \dots, m\}$ set*

$$N_j := \left(\pi - \alpha_j - \frac{(n - n_j)\lambda}{2}, \pi - \alpha_j + \frac{(n - n_j)\lambda}{2} \right)$$

and

$$Z_j := \left\{ e^{it} : t \in \left(\pi - \alpha_j - \frac{n_j\lambda}{2}, \pi - \alpha_j + \frac{n_j\lambda}{2} \right) \right\}.$$

Then, if $x \in N_j$ for a $j \in \{1, \dots, m\}$ with $n_j \geq 2$, $\Delta_\lambda[P; e^{ix}]$ has a pair of zeros in Z_j that is separated by an angle of less than λ .

PROOF. Let $z \in \mathbb{T}$ be a dependent zero of $\Delta_\lambda[P; e^{ix}]$, $x \in \mathbb{R}$. Then

$$-e^{-ix} = \frac{\Delta_\lambda[P](z)}{\Delta_\lambda[P]^*(z)}. \quad (4.18)$$

Applying the relation (cf. (4.14))

$$\Delta_\lambda[P]^*(z) = \frac{e^{in\lambda/2}P(e^{-i\lambda/2}z) - e^{-in\lambda/2}P(e^{i\lambda/2}z)}{2i \sin \frac{n\lambda}{2}}.$$

and the definition of $\Delta_\lambda[P]$ in (4.18) and solving the resulting equation with respect to

$$R(z) := e^{-in\lambda/2} \frac{P(ze^{i\lambda/2})}{P(ze^{-i\lambda/2})},$$

we find that z is a dependent zero of $\Delta_\lambda[P; e^{ix}]$ if, and only if, z is a solution of the equation

$$L(z) := e^{-in\lambda/2} \frac{1 - e^{-i(x-n\lambda/2)}z}{1 - e^{-i(x+n\lambda/2)}z} = R(z).$$

Equivalently, e^{is} , $s \in \mathbb{R}$, is a dependent zero of $\Delta_\lambda[P; e^{ix}]$ if, and only if s is a solution of the equation

$$l(t) := L(e^{it}) = R(e^{it}) =: r(t). \quad (4.19)$$

It follows from Lemma 4.26 that for all $j \in \{1, \dots, m\}$ the function r is a decreasing homeomorphism from T_j to \mathbb{R} (since the r under consideration here coincides with the r in the statement of Lemma 4.26 we will use T , T_j , p_j and z_j as defined in Lemma 4.26). It follows also from Lemma 4.26 that there is a $c \in T$ such that l is decreasing in (p_{m+1}, c) and $(c, p_1]$ while jumping from $-\infty$ to ∞ at c . Since there are exactly $m - 1$ dependent zeros of $\Delta_\lambda[P; e^{ix}]$, this shows that in each of the intervals $\overline{T_j}$, $j \in \{1, \dots, m\}$, there is at most one solution of (4.19).

The independent zeros of $\Delta_\lambda[P; e^{ix}]$ are exactly the zeros of

$$\prod_{j=1}^m Q_{n_j-1}(\lambda; e^{i\alpha_j}z).$$

Therefore, if $t \in T$, then e^{it} is an independent zero of $\Delta_\lambda[P; e^{ix}]$ if, and only if,

$$t = \pi - \alpha_j - \frac{(2l - n_j)\lambda}{2}, \quad l \in \{1, \dots, n_j - 1\},$$

for a $j \in \{1, \dots, m\}$ for which $n_j \geq 2$. Hence, if $n_j \geq 2$ and (4.19) has a solution in Z_j , then in Z_j there is a dependent zero and an independent zero of $\Delta_\lambda[P; e^{ix}]$ that are separated by an angle of less than λ . By Lemma 4.26 the function l vanishes in \mathbb{R} exactly at the points $z^*(k) := x - \frac{n\lambda}{2} + 2k\pi$, has singularities exactly at the points $p^*(k) := x + \frac{n\lambda}{2} + 2k\pi$, and is negative exactly in the intervals $(z^*(k), p^*(k))$ ($k \in \mathbb{Z}$). Hence, (4.19) has a solution in Z_j if, and only if, for any $k \in \mathbb{Z}$

$$\overline{Z}_j = [z_j, p_j] \subset (z^*(k), p^*(k)).$$

It is straightforward to calculate that this holds if, and only if, $x + 2k\pi \in N_j$ for a $k \in \mathbb{Z}$. This proves statement (2).

In order to verify statement (1), suppose first that P is an interior point of $\mathcal{P}_n(\lambda)$. Then $m = n$, $n_j = 1$ for all $j \in \{1, \dots, n\}$, and $\Delta_\lambda[P; e^{ix}]$ has only dependent zeros. Let $s_1 < s_2 < s_3 < s_1 + 2\pi$ be such that $\Delta_\lambda[P; e^{ix}](e^{is_k}) = 0$ for $k \in \{1, 2, 3\}$. Then s_k is a solution of (4.19). Since above we have shown that in each of the intervals \overline{T}_j , $j \in \{1, \dots, n\}$, the equation (4.19) has at most one solution and since, by (4.16),

$$|T_j| = p_j - p_{j+1} = \alpha_{j+1} - \alpha_j - \frac{(n_{j+1} - n_j)\lambda}{2} > n_j\lambda \geq \lambda$$

for all $j \in \{1, \dots, n\}$, it follows that $s_3 - s_1 > \lambda$. We have thus verified the assertion in the case that P is an interior point of $\mathcal{P}_n(\lambda)$. The general case follows from an application of CT. \square

Theorem 4.25 follows easily from the previous lemma.

PROOF OF THEOREM 4.25. Statement (1) is trivial if $n = 3$. If $n = 4$, then $\Delta_\lambda[P; \zeta]$ is of degree 3 for all $\zeta \in \mathbb{T}$ and it is clear that $\Delta_\lambda[P; \zeta]$ must have a pair of zeros that is separated by an angle $\geq \lambda$. If $n \geq 5$, then $\Delta_\lambda[P; \zeta]$ is of degree ≥ 4 for all $\zeta \in \mathbb{T}$. Hence, if $z_1, z_2, z_3 \in \mathbb{T}$ are three consecutive zeros of $\Delta_\lambda[P; \zeta]$, then there must be at least one zero $z_4 \in \mathbb{T}$ lying between z_3 and z_1 . It follows that there are

$$s_1 \leq s_2 \leq s_3 \leq s_4 \leq s_1 + 2\pi$$

such that $z_k = e^{is_k}$, $k \in \{1, \dots, 4\}$. By Lemma 4.27 (1) we have $s_3 - s_1 \geq \lambda$ and $s_1 + 2\pi - s_3 \geq \lambda$ and thus

$$\lambda \leq s_3 - s_1 \leq 2\pi - \lambda.$$

Now, if

$$s_1 \leq s_2 \leq \dots \leq s_{n-1} \leq s_n := s_1 + 2\pi$$

are such that $\Delta_\lambda[P; \zeta](e^{is_k}) = 0$, $k \in \{1, \dots, n-1\}$, then there has to be at least one $j \in \{1, \dots, n-1\}$ such that

$$\lambda \leq s_{j+1} - s_j \leq 2\pi - \lambda$$

and we can assume that the notation is chosen such that $j = n-1$. Hence, all zeros of

$$F(z) := \prod_{k=1}^{\lfloor \frac{n}{2} \rfloor} (z - e^{is_{2k-1}}) \quad \text{and} \quad G(z) := \frac{\Delta_\lambda[P; \zeta](z)}{F(z)}$$

lie on the unit circle and each pair of zeros of F or G is separated by an angle $\geq \lambda$. Statement (1) is thus proven.

Next, let $n \geq 7$ and suppose that $P \in \mathcal{P}_n(\lambda)$ has a standard representation of the form (4.15) with $m = n-3$, $n_1 = 3$, $n_{m/2} = 2$, $\alpha_1 = 0$ and $\alpha_{m/2} = \pi$ if n is odd and $m = n-2$, $n_1 = n_{m/2} = 2$, $\alpha_1 = 0$ and $\alpha_{m/2} = \pi$ if n is even. Define the sets Z_j and N_j as in Lemma 4.27. If $\lambda \in (\frac{\pi}{n-3}, \frac{2\pi}{n})$, then it follows from the definition of our P that $N_1 \cup N_{m/2} = \mathbb{T}$ and $N_1 \cap N_{m/2} \neq \emptyset$. Hence, because of Lemma 4.27 (2), for all $\zeta \in \mathbb{T}$

the polynomial $\Delta_\lambda[P; \zeta]$ has a pair of zeros on \mathbb{T} that is separated by an angle of less than λ . This proves statement (2). Since by (4.16) we have $Z_1 \cap Z_{m/2} = \emptyset$, Lemma 4.27 (2) also shows that for $\zeta \in N_1 \cap N_{m/2}$ the polynomial $\Delta_\lambda[P; \zeta]$ has at least two pairs of zeros (one in Z_1 and one in $Z_{m/2}$) that are separated by an angle of less than λ . This proves statement (3) and thus the theorem. \square

Theorem 4.17 shows that if $P \in \mathcal{P}_n(\lambda)$, then all zeros of $P *_\lambda Q$ lie on the unit circle if

$$Q = (1 + \zeta z)R \quad \text{with} \quad \zeta \in \mathbb{T}, R \in \mathcal{P}_{n-1}(\lambda), \quad (4.20)$$

or

$$Q = \Delta_\lambda[R; \zeta] \quad \text{with} \quad \zeta \in \mathbb{T}, R \in \mathcal{P}_{n+1}(\lambda), \quad (4.21)$$

and R not equal to a rotation of $Q_{n+1}(\lambda; z)$. This raises the question whether there exists a 'simple' condition C such that all polynomials Q of the form (4.20) or (4.21) satisfy C and such that for all $P \in \mathcal{P}_n(\lambda)$ and all polynomials Q that satisfy C all zeros of $P *_\lambda Q$ lie on the unit circle. C has to be more specific than the condition 'has all its zeros on \mathbb{T} ', since otherwise for every $p \in \mathcal{S}_n(\lambda)$ we would have $p * Q_n(0; z) \in \mathcal{P}_n(0)$ or, equivalently, $p \in \mathcal{S}_n(0)$, in contradiction to Suffridge's inclusion theorem 4.3 (2). In this context Theorem 4.25 (1) is of some interest, since it reveals a common feature of polynomials of the form (4.20) and (4.21).

4.4. On a Question of Suffridge

In this section we will give an answer to a question posed by Suffridge in [Suf76] concerning the iterated application of the Δ_λ -operator.

For $\lambda \in [0, \frac{2\pi}{n})$ define $\Delta_\lambda^{(0)}[P] = P$ and

$$\Delta_\lambda^{(j)}[P] = \Delta_\lambda[\Delta_\lambda^{(j-1)}[P]], \quad j \in \mathbb{N}.$$

In [Suf76] Suffridge asked whether in analogy to the case $\lambda = 0$ it is true that for $\lambda \in (0, \frac{2\pi}{n})$, $P \in \mathcal{P}_n(\lambda)$ and $j = 0, \dots, n$ all zeros of $\Delta_\lambda^{(j)}[P]$ lie in the closed unit disk. It was proven in [Lam05, Thm. 3.14] that if $\lambda \in [0, \frac{\pi}{n}]$, then all zeros of $\Delta_\lambda^{(2)}[P]$ lie in the closed unit disk for all $P \in \mathcal{P}_n(\lambda)$. However, as we are now in a position to show, the answer to Suffridge's question is, in general, negative.

THEOREM 4.28. *For all $n \geq 8$ there is a $\delta_n > 0$ such that to each $\lambda \in (\frac{2\pi}{n} - \delta_n, \frac{2\pi}{n})$ there is a $P \in \mathcal{P}_n(\lambda)$ for which $\Delta_\lambda^{(2)}[P]$ has zeros outside the closed unit disk.*

In fact, we will show the following stronger statement.

THEOREM 4.29. *For all $n \geq 8$ there is a $\delta_n > 0$ such that to each $\lambda \in (\frac{2\pi}{n} - \delta_n, \frac{2\pi}{n})$ there is a $P \in \mathcal{P}_n(\lambda)$ and a $c > 1$ such that for all $|\zeta| \geq 1$ the polynomial $\Delta_\lambda[\Delta_\lambda[P; \zeta]]$ has a zero of modulus $> c$.*

Since

$$\frac{1}{\zeta} \Delta_\lambda[P; \zeta] \rightarrow \Delta_\lambda[P]$$

as $\zeta \rightarrow \infty$, it is easy to see that Theorem 4.29 implies Theorem 4.28. Note also that, because of Theorems 4.8 and 4.23, the polynomial P that appears in Theorem 4.29 is such that for all $\zeta \in \mathbb{T}$ the polynomial $\Delta_\lambda[P; \zeta]$ has a pair of zeros that is separated by an angle of less than λ . Therefore Theorem 4.29 also implies a weaker form of Theorem 4.25 (2).

PROOF OF THEOREM 4.29. Because of the definition of $\Delta_\lambda[P; \zeta]$ it will be enough to show that for all $n \geq 8$ and λ close to $\frac{2\pi}{n}$ there is a $P \in \mathcal{P}_n(\lambda)$ such that for all $\zeta \in \overline{\mathbb{D}}$ the polynomial

$$\Delta_\lambda[\zeta \Delta_\lambda[P]^* + \Delta_\lambda[P]]$$

has a zero outside $\overline{\mathbb{D}}$.

To this end, we will present a polynomial $p \in \mathcal{S}_n(\frac{2\pi}{n})$ for which there is a $c_n > 1$ such that for all $\zeta \in \overline{\mathbb{D}}$

$$\delta^{(2)}[p; \zeta] := \Delta_{\frac{2\pi}{n}}[\zeta \delta[p]^* + \delta[p]]$$

has a zero of modulus $> c_n$. For then, it follows from (4.5), (4.13), Suffridge's inclusion theorem 4.3 (2), and the continuity of the coefficients $\binom{n-1}{k}_\lambda$ with respect to λ that to each $\epsilon > 0$ there is a $\delta > 0$ such that for every $\lambda \in (\frac{2\pi}{n} - \delta, \frac{2\pi}{n})$ there is a $P_\lambda = p_\lambda * Q_n(\lambda; z) \in \mathcal{P}_n(\lambda)$ with (we identify \mathcal{P}_n with the normed space \mathbb{C}^{n+1})

$$\|\Delta_\lambda[P_\lambda] - \delta[p]\| = \left\| \delta[p_\lambda] * Q_{n-1}(\lambda; z) - \delta[p] * Q_{n-1}\left(\frac{2\pi}{n}; z\right) \right\| < \epsilon.$$

Hence, since for all $|\zeta| \leq 1$ and $P \in \mathcal{P}_n$

$$\begin{aligned} \left\| \Delta_\lambda[\zeta \Delta_\lambda[P]^* + \Delta_\lambda[P]] - \Delta_{\frac{2\pi}{n}}[\zeta \delta[p]^* + \delta[p]] \right\| &\leq \\ &\leq \left\| \Delta_\lambda[\Delta_\lambda[P]^*] - \Delta_{\frac{2\pi}{n}}[\delta[p]^*] \right\| + \left\| \Delta_\lambda[\Delta_\lambda[P]] - \Delta_{\frac{2\pi}{n}}[\delta[p]] \right\|, \end{aligned}$$

a compactness argument, CT, and the continuity of the coefficients $\binom{n-2}{k}_\lambda$ give the required result.

In order to find polynomials $p \in \mathcal{S}_n(\frac{2\pi}{n})$ as described above, note first that by (4.5)

$$Q_{n-2}\left(\frac{2\pi}{n}; z\right) = \Delta_{\frac{2\pi}{n}}\left[Q_{n-1}\left(\frac{2\pi}{n}; z\right)\right](z) = \sum_{k=0}^{n-2} \frac{\sin(k+1)\frac{\pi}{n}}{\sin(n-1)\frac{\pi}{n}} z^k$$

and therefore

$$\binom{n-2}{k}_{\frac{2\pi}{n}} = \frac{\sin(k+1)\frac{\pi}{n}}{\sin\frac{\pi}{n}} \quad \text{for } k \in \{0, \dots, n-2\}. \quad (4.22)$$

Now, consider the polynomial $p(z) = 1 + z^m + z^{2m}$, $m \in \mathbb{N}$. Then $\delta[p](z) = z^{m-1} + z^{2m-1}$ has all its zeros in the closed unit disk and hence $p \in \mathcal{S}_n(\frac{2\pi}{n})$ (cf. the remark before Lemma 4.10). Furthermore, because of (4.22),

$$\delta^{(2)}[p; \zeta](z) = \cot \frac{\pi}{2m} z^{m-2} + \zeta \binom{2m-2}{m-1}_{\frac{\pi}{m}} z^{m-1} + z^{2m-2}, \quad \zeta \in \mathbb{C}.$$

Hence, if $m \geq 3$, then for all $\zeta \in \mathbb{C}$ the polynomial $\delta^{(2)}[p; \zeta]$ has a zero of modulus $\geq (\cot \frac{\pi}{2m})^{1/m} > 1$.

Next, let $p(z) = 1 + \frac{1}{2}(z^m + z^{m+1}) + z^{2m+1}$, $m \in \mathbb{N}$. It follows easily from Rouché's theorem that for $t \in (0, \frac{1}{2})$ all zeros of $t(z^{m-1} + z^m) + z^{2m}$ lie in \mathbb{D} . Therefore all zeros of $\delta[p](z) = \frac{1}{2}(z^{m-1} + z^m) + z^{2m}$ lie in the closed unit disk and p is a member of $\mathcal{S}_n(\frac{2\pi}{n})$. For every $\zeta \in \mathbb{C}$ there are $A_\zeta, B_\zeta \in \mathbb{C}$ such that

$$\frac{\delta^{(2)}[p; \zeta](z)}{z^{m-2}} = \frac{\sin \frac{(m-1)\pi}{2m+1}}{2 \sin \frac{\pi}{2m+1}} + A_\zeta z + B_\zeta z^2 + z^{m+1} \quad (4.23)$$

and therefore if

$$d_m := \frac{\sin \frac{(m-1)\pi}{2m+1}}{2 \sin \frac{\pi}{2m+1}} > 1, \quad (4.24)$$

then, for all $\zeta \in \mathbb{C}$, $\delta^{(2)}[p; \zeta](z)$ will have a zero of modulus $\geq d_m^{1/(m+1)} > 1$. One can easily check that (4.24) holds for all $m \geq 4$. \square

As a final remark in this chapter we will explain how Lemma 4.27 (2) motivates the use of the polynomial $p(z) = 1 + z^m + z^{2m}$ in the proof of Theorem 4.29.

By Lemma 4.27 (2) every factor $Q_{n_j}(\lambda; e^{i\alpha_j} z)$ with $n_j = 2$ in the standard representation of a polynomial $P \in \mathcal{P}_n(\lambda)$ leads to a 'large' arc on the unit circle that contains only ζ for which $\Delta_\lambda[P; \zeta]$ has a pair of zeros separated by an angle of less than λ . It is easy to see that for $m \in \mathbb{N}$ and $\lambda \in [0, \frac{\pi}{m})$

$$P_\lambda(z) := 1 + 2 \cos \frac{m\lambda}{2} z^m + z^{2m} = \prod_{j=1}^m Q_2(\lambda; e^{2ij\pi/m} z) \in \mathcal{P}_{2m}(\lambda).$$

It follows from (4.1) that

$$\frac{\binom{2m}{m}_\lambda}{\binom{2m-1}{m-1}_\lambda} = 2 \cos \frac{m\lambda}{2}$$

and therefore, for all $\lambda \in [0, \frac{\pi}{m})$

$$p_\lambda(z) := P_\lambda * Q_{2m}^{(-1)}(\lambda; z) = 1 + \frac{1}{\binom{2m-1}{m-1}_\lambda} z^m + z^{2m} \in \mathcal{S}_{2m}(\lambda).$$

Since $\binom{2m-1}{m-1}_{\pi/m} = 1$, p_λ converges to

$$p(z) = 1 + z^m + z^{2m} \in \mathcal{S}_{2m}\left(\frac{\pi}{m}\right)$$

as $\lambda \rightarrow \frac{\pi}{m}$.

On Some Integral Operators in Geometric Function Theory

The class \mathcal{S} of functions $f \in \mathcal{A}_0$ that are univalent in the open unit disk is the main object of investigation in geometric function theory. Important subclasses of \mathcal{S} are the class \mathcal{K} of convex functions (cf. Ch. 4), the classes \mathcal{S}_α^* , $\alpha \in [0, 1]$, of functions starlike of order α (cf. Ch. 2), the class \mathcal{C} of close-to-convex functions, and the classes \mathcal{SP}_β of functions spirallike of order β , $\beta \in (-\frac{\pi}{2}, \frac{\pi}{2})$. A function $f \in \mathcal{A}_0$ is called *close-to-convex* if there is a function $g \in \mathcal{K}$ such that

$$\operatorname{Re} \frac{f'(z)}{g'(z)} > 0 \quad \text{for } z \in \mathbb{D},$$

and *spirallike of order β* if there is a $\beta \in (-\frac{\pi}{2}, \frac{\pi}{2})$ such that

$$\operatorname{Re} e^{i\beta} \frac{zf'(z)}{f(z)} > 0 \quad \text{for } z \in \mathbb{D}.$$

For reasons of brevity we will call starlike functions of order 0 simply *starlike functions* and set $\mathcal{S}^* := \mathcal{S}_0^*$. Starlike functions map the unit disk univalently onto a domain that is starlike with respect to the origin. Recall that a subset M of a (real or complex) vector space V is called *starlike* (with respect to the zero element 0 of V) if for all $v \in M$ the straight line $t \cdot v$, $t \in [0, 1]$, between 0 and v lies completely in M .

One of the classical results concerning convex and starlike functions is Alexander's theorem: f belongs to \mathcal{S}^* if, and only if,

$$J[f](z) := \int_0^z \frac{f(\zeta)}{\zeta} d\zeta$$

belongs to \mathcal{K} . The fact that J maps the class \mathcal{S}^* into a small subclass of itself may have motivated Biernacki [Bie60] to conjecture that for all $f \in \mathcal{S}$ the function $J[f]$ is also in \mathcal{S} . Even though Krzyż and Lewandowski [KL63] showed soon afterwards that this is not true, Biernacki's conjecture initiated the study of integral operators in geometric function theory.

Among the many integral operators studied,

$$J_\alpha[f](z) := \int_0^z \left(\frac{f(\zeta)}{\zeta} \right)^\alpha d\zeta \quad \text{and} \quad I_\alpha[f](z) := \int_0^z (f'(\zeta))^\alpha d\zeta,$$

attracted particular attention. $J_\alpha = I_\alpha \circ J$ is defined for $\alpha \in \mathbb{C}$ and functions $f \in \mathcal{A}_0$ for which $f/z \neq 0$ in \mathbb{D} , while I_α is defined for $\alpha \in \mathbb{C}$ and functions $f \in \mathcal{A}_0$ for which $f' \neq 0$ in \mathbb{D} . The branch of the logarithm is taken such that $J'_\alpha[f](0) = I'_\alpha[f](0) = 1$.

The main open problem concerning both operators is to determine the points $\alpha \in \mathbb{C}$ for which $f \in \mathcal{S}$ implies $J_\alpha[f] \in \mathcal{S}$ or $I_\alpha[f] \in \mathcal{S}$. It is known that $J_\alpha[f] \in \mathcal{S}$ and $I_\alpha[f] \in \mathcal{S}$ for all $f \in \mathcal{S}$ if $|\alpha| \leq \frac{1}{4}$ [KM72, Pfa75]. Furthermore, for each $|\alpha| \geq \frac{1}{2}$ with $\alpha \neq 1$ one can find an $f \in \mathcal{S}$ such that $J_\alpha[f] \notin \mathcal{S}$ [KM72] and for each $|\alpha| \geq \frac{1}{3}$ with $\alpha \neq 1$ there is an $f \in \mathcal{S}$ such that $I_\alpha[f] \notin \mathcal{S}$ [Roy65].

More is known if J_α and I_α are restricted to subclasses of \mathcal{S} . For example, it is shown in [AN82] that $I_\alpha[f] \in \mathcal{S}$ for all $f \in \mathcal{K}$ if, and only if, $|\alpha| \leq \frac{1}{2}$ or $\alpha \in [\frac{1}{2}, \frac{3}{2}]$. In [Mer] it is proven that $J_\alpha[f] \in \mathcal{S}$ for all $f \in \mathcal{SP}$ if, and only if, $|\alpha| \leq \frac{1}{2}$.

For real α the following results concerning the images of the classes \mathcal{K} , \mathcal{S}^* , and \mathcal{C} under the operators J_α and I_α have been obtained.

THEOREM 5.1. [MW71] *Let $\alpha \in \mathbb{R}$.*

- (1) $J_\alpha[f] \in \mathcal{S}$ (in fact $J_\alpha[f] \in \mathcal{C}$) for all $f \in \mathcal{K}$ if, and only if, $\alpha \in [-1, 3]$.
- (2) $J_\alpha[f] \in \mathcal{S}$ (in fact $J_\alpha[f] \in \mathcal{C}$) for all $f \in \mathcal{S}^*$ if, and only if, $\alpha \in [-\frac{1}{2}, \frac{3}{2}]$.
- (3) $J_\alpha[f] \in \mathcal{S}$ (in fact $J_\alpha[f] \in \mathcal{C}$) for all $f \in \mathcal{C}$ if, and only if, $\alpha \in [-\frac{1}{2}, 1]$.
- (4) $I_\alpha[f] \in \mathcal{S}$ (in fact $I_\alpha[f] \in \mathcal{C}$) for all $f \in \mathcal{K}$ if, and only if, $\alpha \in [-\frac{1}{2}, \frac{3}{2}]$.
- (5) $I_\alpha[f] \in \mathcal{S}$ (in fact $I_\alpha[f] \in \mathcal{C}$) for all $f \in \mathcal{C}$ if, and only if, $\alpha \in [-\frac{1}{3}, 1]$.

The operator I_α plays also an important role in the Hornich theory.

Let \mathcal{H} denote the class of functions f in \mathcal{A}_0 that are locally univalent, i.e. that satisfy $f' \neq 0$ in \mathbb{D} . In [Hor69] Hornich introduced an addition and a scalar multiplication for functions in the class \mathcal{H} . For $f, g \in \mathcal{H}$ and $\alpha \in \mathbb{C}$ the *Hornich operations* are defined by

$$(f \oplus g)(z) := \int_0^z f'(\zeta)g'(\zeta) d\zeta$$

and

$$(\alpha \odot f)(z) := I_\alpha[f](z) = \int_0^z (f'(\zeta))^\alpha d\zeta.$$

It is clear that with these operations the set \mathcal{H} becomes a complex vector space – the *Hornich space* – with zero element $\text{id} : z \mapsto z$. Obviously, \mathcal{S} is a subset of \mathcal{H} . Even though in general the Hornich sum of two functions in \mathcal{S} is not univalent, it will at least be locally univalent.

This, of course, does not have to be true for the usual sum of two functions in \mathcal{S} and led to a closer examination of the linear structure of \mathcal{S} and its subclasses in the Hornich space. Besides the results concerning the operator I_α mentioned above, the following linear properties of the classes \mathcal{K} and \mathcal{C} have been verified.

THEOREM 5.2.

- (1) \mathcal{K} is convex in \mathcal{H} , i.e. for $f, g \in \mathcal{K}$ and $t \in [0, 1]$ also $[t \odot f] \oplus [(1-t) \odot g] \in \mathcal{K}$ [CP70].
- (2) \mathcal{C} is convex in \mathcal{H} [KM74].

So far it seems to have gone unnoticed that Theorem 5.2 and the 'if'-directions of Theorem 5.1 can easily be obtained - and strengthened - by using the theory of Kaplan classes. In the following we shall give a short outline of the definition and properties of Kaplan classes. For a more thorough treatment of Kaplan classes we refer to [Rus82] and [SS02, Ch. 7, 8].

For $\alpha, \beta \geq 0$ the *Kaplan class* $K(\alpha, \beta)$ is defined to be the set of functions $f \in \mathcal{A}_1$ that satisfy

$$-\alpha\pi - \frac{1}{2}(\alpha - \beta)(\theta_1 - \theta_2) \leq \arg f(re^{i\theta_2}) - \arg f(re^{i\theta_1}) \quad (5.1)$$

for $0 < r < 1$ and $\theta_1 < \theta_2 < \theta_1 + 2\pi$. Considering the couple $(\theta_2, \theta_1 + 2\pi)$ instead of (θ_1, θ_2) in (5.1) one sees that $f \in K(\alpha, \beta)$ if, and only if, $f \in \mathcal{A}_1$ and

$$\beta\pi - \frac{1}{2}(\alpha - \beta)(\theta_1 - \theta_2) \geq \arg f(re^{i\theta_2}) - \arg f(re^{i\theta_1}) \quad (5.2)$$

for $0 < r < 1$ and $\theta_1 < \theta_2 < \theta_1 + 2\pi$. From those two characterizations of functions in $K(\alpha, \beta)$ the following properties of Kaplan classes are easily obtained.

LEMMA 5.3. [*SS02*, p. 245] Let $\alpha, \beta, \lambda, \mu \geq 0$.

- (1) If $f \in K(\alpha, \beta)$, then $f^{-1} \in K(\beta, \alpha)$.
- (2) If $f \in K(\alpha, \beta)$, $g \in K(\lambda, \mu)$, and $s, t \geq 0$, then $f^s g^t \in K(s\alpha + t\lambda, s\beta + t\mu)$.
- (3) If $\alpha \leq \lambda$ and $\beta \leq \mu$, then $K(\alpha, \beta) \subseteq K(\lambda, \mu)$.

Kaplan classes are related to the classes \mathcal{K} , \mathcal{S}_α^* and \mathcal{C} in the following way.

LEMMA 5.4. [*Rus82*, Ch. 2]

- (1) $f \in \mathcal{K}$ if, and only if, $f' \in K(0, 2)$.
- (2) $f \in \mathcal{S}_\alpha^*$ if, and only if, $f/z \in K(0, 2 - 2\alpha)$.
- (3) $f \in \mathcal{C}$ if, and only if, $f' \in K(1, 3)$.
- (4) If $f \in \mathcal{K}$, then $f/z \in K(0, 1)$.
- (5) If $f \in \mathcal{C}$, then $f/z \in K(1, 2)$.

Theorem 5.2 and the 'if'-directions of Theorem 5.1 follow easily from Lemmas 5.3 and 5.4. In order to illustrate this we shall verify the 'if'-direction of Theorem 5.1 (1): if $f \in \mathcal{K}$, then $f/z \in K(0, 1)$. Therefore, $J'_\alpha[f] = (f/z)^\alpha \in K(0, \alpha)$ if $\alpha \geq 0$ and $J'_\alpha[f] \in K(\alpha, 0)$ if $\alpha \leq 0$. Hence, for $\alpha \in [-1, 3]$ we have $J'_\alpha[f] \in K(1, 3)$ and thus $J_\alpha[f] \in \mathcal{C} \subset \mathcal{S}$.

In contrast to the classes \mathcal{K} and \mathcal{C} , the set of derivatives of functions in the class \mathcal{S}^* is not equal to a Kaplan class. This is the reason why statements concerning the operator I_α and the class \mathcal{S}^* are considerably harder to obtain than those concerning I_α and the classes \mathcal{K} and \mathcal{C} .

In this chapter we will give (partial) answers to the following two questions which are motivated by Theorems 5.1 and 5.2 and which until recently had been open: What is the set of $\alpha \in \mathbb{R}$ (or even $\alpha \in \mathbb{C}$) for which $f \in \mathcal{S}^*$ implies $I_\alpha[f] \in \mathcal{S}$, and what is the linear structure of the set \mathcal{S}^* in the Hornich space? In order to answer the second question we will present a very interesting new property of starlike functions that, at first sight, seems completely unrelated to the question itself. The results of the first two sections can also be found in [*Lam07*].

5.1. A New Property of Starlike Functions

In this section we will show that the class \mathcal{S}^* behaves very interestingly under a certain nonlinear integral operator.

The following nice property of starlike functions had been unknown until recently.

THEOREM 5.5. Let $f \in \mathcal{S}^*$, $z \in \mathbb{D}$, and set $\gamma(t) := f^{-1}(tf(z))$, $t \in [0, 1]$. Then

$$\left| \int_0^1 \arg \frac{z}{\gamma'(t)} dt \right| < \frac{\pi}{2}.$$

It is easy to verify that the integral operator

$$T[f](z) := \int_0^z \frac{f'(\zeta)}{f(\zeta)} \log \frac{zf'(\zeta)}{f(z)} d\zeta, \quad z \in \mathbb{D},$$

is analytic in \mathbb{D} when $f \in \mathcal{S}$. If $f \in \mathcal{S}^*$, then we can choose the special integration path $\gamma(t) := f^{-1}(tf(z))$, $t \in [0, 1]$. In this case, $\gamma'(t)f'(\gamma(t)) = f(z)$ for $t \in [0, 1]$ and thus $T[f](z) = \int_0^1 \log(z/\gamma'(t)) dt$. Therefore Theorem 5.5 is equivalent to the following statement.

THEOREM 5.6. *Let $f \in \mathcal{S}^*$. Then $|\operatorname{Im} T[f](z)| < \frac{\pi}{2}$ for $z \in \mathbb{D}$.*

In this section we will present a proof of this result. We begin by verifying some elementary properties of the integral operator T .

LEMMA 5.7. *Let $f \in \mathcal{S}^*$. Then $\operatorname{Im} T[f]$ is in h^∞ , i.e. $\operatorname{Im} T[f]$ is a bounded harmonic function in \mathbb{D} . Further, if f has an analytic extension to a neighborhood N of a point $w = e^{it_0} \in \mathbb{T}$, then $T[f]$ is continuous in $\mathbb{D} \cup (\mathbb{T} \cap N)$ and $t \mapsto T[f](e^{it})$ is differentiable in t_0 . If $f'(w) = 0$, then*

$$\lim_{z \rightarrow w, z \in \overline{\mathbb{D}}} f'(z) \log f'(z) = 0. \quad (5.3)$$

PROOF. Let $z \in \mathbb{D}$ and set $\gamma(t) := f^{-1}(tf(z))$, $t \in [0, 1]$. Then $\gamma'(t)f'(\gamma(t)) = f(z)$ for $t \in [0, 1]$ and thus

$$\operatorname{Im} T[f](z) = \int_0^1 \arg f'(\gamma(t)) dt - \arg \frac{f(z)}{z}.$$

Since $|\arg f'(z)| < \frac{3\pi}{2}$ and $|\arg f(z)/z| < \pi$ in \mathbb{D} for all functions $f \in \mathcal{S}^*$ [Goo53], we find that $|\operatorname{Im} T[f](z)| < \frac{5\pi}{2}$ for all $z \in \mathbb{D}$. Since $T[f]$ is analytic in \mathbb{D} , it follows that $\operatorname{Im} T[f] \in h^\infty$.

Now suppose that f has an analytic extension to a neighborhood N of a point $w = e^{it_0} \in \mathbb{T}$. Since by Koebe's $\frac{1}{4}$ -theorem $f(w) \neq 0$, it is clear that if f' does not vanish at w , then $T[f]$ is continuous in $\mathbb{D} \cup (\mathbb{T} \cap N)$ and $t \mapsto T[f](e^{it})$ is differentiable in t_0 . Since

$$T[f](z) = \frac{1}{f(z)} \int_0^z f'(\zeta) \log f'(\zeta) d\zeta - \log \frac{f(z)}{z}, \quad (5.4)$$

it is also clear that the same will hold in the case $f'(w) = 0$ once we have shown (5.3). Thus, suppose that $f'(w) = 0$. Since $|\arg f'(z)| < \frac{3\pi}{2}$ in \mathbb{D} for all functions $f \in \mathcal{S}^*$, we have

$$\lim_{z \rightarrow w, z \in \overline{\mathbb{D}}} |f'(z) \log f'(z)| \leq \lim_{z \rightarrow w, z \in \overline{\mathbb{D}}} |f'(z)| \left(\log |f'(z)| + \frac{3\pi}{2} \right) = 0,$$

as required. \square

Our further examination of the properties of the operator T will be based on the fact that it satisfies an interesting differential equation.

LEMMA 5.8. *Let $f \in \mathcal{S}^*$ and suppose that f has an analytic extension to a neighborhood of a point $w = re^{it_0} \in \mathbb{D}$, $0 \leq r \leq 1$, $t_0 \in \mathbb{R}$. Then, if $f'(w) \neq 0$,*

$$\left. \frac{d}{dt} T[f](re^{it}) \right|_{t=t_0} = iwT[f]'(w) = i + \frac{iwf'(w)}{f(w)} \left(\log \frac{wf'(w)}{f(w)} - 1 - T[f](w) \right), \quad (5.5)$$

while

$$\left. \frac{d}{dt} T[f](e^{it}) \right|_{t=t_0} = \lim_{z \rightarrow w, z \in \overline{\mathbb{D}}} izT[f]'(z) = i, \quad (5.6)$$

in the case that $f'(w) = 0$.

PROOF. Using the representation (5.4) of $T[f]$, a simple calculation shows that if $f'(w) \neq 0$, then

$$\begin{aligned} \left. \frac{d}{dt} T[f](re^{it}) \right|_{t=t_0} &= i + \frac{iwf'(w)}{f(w)} \left(\log f'(w) - 1 - \int_0^w \frac{f'(\zeta)}{f(w)} \log f'(\zeta) d\zeta \right) \\ &= i + \frac{iwf'(w)}{f(w)} \left(\log \frac{wf'(w)}{f(w)} - 1 - T[f](w) \right). \end{aligned}$$

If $f'(w) = 0$, then, because of (5.3),

$$\left. \frac{d}{dt} T[f](e^{it}) \right|_{t=t_0} = i - \frac{iw f'(w)}{f^2(w)} \int_0^w f'(\zeta) \log f'(\zeta) d\zeta - \frac{iw f'(w)}{f(w)} = i.$$

□

As a first application of this differential equation we obtain the following.

LEMMA 5.9. *Let $f \in \mathcal{S}^*$ and suppose that there is a $w = e^{is} \in \mathbb{T}$ such that f has an analytic extension to a neighborhood N of w and satisfies $\operatorname{Re} w f'(w)/f(w) = 0$ and $|\operatorname{Im} T[f](z)| < |\operatorname{Im} T[f](w)|$ in \mathbb{D} . Then $f'(w) \neq 0$ and $\operatorname{Im} T[f](w) < \frac{\pi}{2}$ if $\arg w f'(w)/f(w) = \frac{\pi}{2}$ and $\operatorname{Im} T[f](w) > -\frac{\pi}{2}$ if $\arg w f'(w)/f(w) = -\frac{\pi}{2}$.*

PROOF. Since $|\operatorname{Im} T[f](z)| < |\operatorname{Im} T[f](w)|$ in \mathbb{D} , we have

$$\left. \frac{d}{dt} \operatorname{Im} T[f](e^{it}) \right|_{t=s} = 0$$

and therefore $f'(w) \neq 0$ by Lemma 5.8. Taking the imaginary part of (5.5) and setting $r := iw f'(w)/f(w)$ and $\varphi := \arg(-ir)$, we obtain

$$1 + r(\varphi - \operatorname{Im} T[f](w)) = 0.$$

Since $\varphi = \pm \frac{\pi}{2}$ and $r\varphi < 0$, the lemma follows. □

Next, for $n \in \mathbb{N}$ let \mathcal{D}_n be the set of functions f of the form

$$f(z) = \frac{z}{\prod_{j=1}^n (1 - ze^{-i\theta_j})^{\alpha_j}}, \quad (5.7)$$

where $\theta_j < \theta_{j+1}$ for $1 \leq j \leq n$ ($\theta_{n+1} := \theta_1 + 2\pi$) as well as $\alpha_j > 0$ and $\sum_{j=1}^n \alpha_j = 2$; in addition, set $\mathcal{D} := \bigcup_{n \in \mathbb{N}} \mathcal{D}_n$. We have $\mathcal{D} \subset \mathcal{S}^*$. In fact, a function $f \in \mathcal{D}_n$ as above maps the unit disk onto the complement of n rays lying on straight lines through the origin:

Since for $t \in (\theta_1, \theta_{n+1})$, $t \neq \theta_j$,

$$f(e^{it}) = -e^{i(\sum_{j=1}^n \theta_j \alpha_j)/2} \prod_{j=1}^n \left(2 \sin \frac{\theta_j - t}{2} \right)^{-\alpha_j},$$

for $t \in (\theta_j, \theta_{j+1})$, $j = 1, \dots, n$, the argument of $f(e^{it})$ is constant. Further, writing $r(t) := ie^{it} f'(e^{it})/f(e^{it})$ we have

$$r(t) = - \sum_{j=1}^n \frac{\alpha_j}{2} \cot \frac{t - \theta_j}{2} \quad \text{and} \quad r'(t) = \sum_{j=1}^n \frac{\alpha_j}{4 \sin^2 \frac{t - \theta_j}{2}} > 0,$$

and therefore for each $1 \leq j \leq n$ there is exactly one $\phi_j \in (\theta_j, \theta_{j+1})$ such that $f'(e^{i\phi_j}) = 0$ and such that $r(t) < 0$ for $t \in (\theta_j, \phi_j)$ and $r(t) > 0$ for $t \in (\phi_j, \theta_{j+1})$. Since for $t \neq \theta_j$

$$\frac{d}{dt} \log |f(e^{it})| = \operatorname{Re} r(t) = r(t),$$

it thus follows that $t \mapsto |f(e^{it})|$ decreases from ∞ to $|f(e^{i\phi_j})|$ in (θ_j, ϕ_j) and increases from $|f(e^{i\phi_j})|$ to ∞ in (ϕ_j, θ_{j+1}) . Likewise, we obtain

$$\arg \frac{e^{it} f'(e^{it})}{f(e^{it})} = \frac{\pi}{2} \quad \text{and} \quad \arg \frac{e^{it} f'(e^{it})}{f(e^{it})} = -\frac{\pi}{2} \quad (5.8)$$

for $t \in (\theta_j, \phi_j)$ and $t \in (\phi_j, \theta_{j+1})$, respectively.

It is a classical result in geometric function theory that the set \mathcal{D} is dense in \mathcal{S}^* with respect to the compact open topology of the class \mathcal{A}_0 . One way to see this is to apply the fact that $f \in \mathcal{S}^*$ if, and only if, there is a probability measure $\mu(t)$ on $[0, 2\pi]$ such that (cf. [Goo83, p. 122])

$$f(z) = z \exp \left(-2 \int_0^{2\pi} \log(1 - ze^{-it}) d\mu(t) \right).$$

It will therefore suffice to prove Theorem 5.6 for functions in \mathcal{D} . Further, since by Lemma 5.7 $\text{Im } T[f] \in h^\infty$ for $f \in \mathcal{S}^*$, we have

$$\text{Im } T[f](z) = \frac{1}{2\pi} \int_0^{2\pi} P(e^{it}, z) \text{Im } T[f](e^{it}) dt \quad (z \in \mathbb{D}),$$

where $P(e^{it}, z) = \text{Re}(e^{it} + z)/(e^{it} - z)$ is the Poisson kernel [ABR01, Ch. 6]. Since

$$\frac{1}{2\pi} \int_0^{2\pi} P(e^{it}, z) dt = 1$$

and $P(e^{it}, z) > 0$ for all $z \in \mathbb{D}$ and $t \in \mathbb{R}$ [ABR01, Prop. 1.20], it will thus be enough to show the following statement in order to prove Theorem 5.6.

LEMMA 5.10. *For $f \in \mathcal{D}$ like in (5.7) we have $|\text{Im } T[f](e^{it})| < \frac{\pi}{2}$ for all $t \in (\theta_1, \theta_{n+1})$, $t \neq \theta_j$.*

First we will show that this is true in the limit case where t tends to θ_j .

To this end, for $\theta \in (\theta_j, \theta_{j+1})$ set $\gamma_\theta(t) = f^{-1}(tf(e^{i\theta}))$, $0 \leq t \leq 1$, where the branch of f^{-1} is chosen such that $\gamma_\theta(1) = e^{i\theta}$. Then $\gamma_\theta(0) = 0$ and

$$\gamma'_\theta(t) f'(\gamma_\theta(t)) = f(e^{i\theta}) \quad (5.9)$$

for all $t \in [0, 1]$ for which $\gamma_\theta(t) \neq e^{i\phi_j}$ (there exists only one such t). For $\theta, \theta^* \in \mathbb{R}$ with $\theta, \theta^* \in (\theta_j, \phi_j)$ or $\theta, \theta^* \in (\phi_j, \theta_{j+1})$ set

$$\gamma_{\theta, \theta^*}(t) = f^{-1}(f(e^{i\theta}) + t(f(e^{i\theta^*}) - f(e^{i\theta}))), \quad (0 \leq t \leq 1)$$

where the branch of f^{-1} is chosen such that $\gamma_{\theta, \theta^*}(0) = e^{i\theta}$. Then $\gamma_{\theta, \theta^*}(1) = e^{i\theta^*}$ and

$$\gamma'_{\theta, \theta^*}(t) f'(\gamma_{\theta, \theta^*}(t)) = f(e^{i\theta^*}) - f(e^{i\theta}) \quad \text{for } 0 \leq t \leq 1. \quad (5.10)$$

LEMMA 5.11. *For $f \in \mathcal{D}_n$ as in (5.7) and $j = 1, \dots, n$ we have*

$$\lim_{\theta \rightarrow \theta_j^+} \text{Im } T[f](e^{i\theta}) = \frac{\pi}{2} \quad \text{and} \quad \lim_{\theta \rightarrow \theta_{j+1}^-} \text{Im } T[f](e^{i\theta}) = -\frac{\pi}{2}.$$

In particular, the bound $\frac{\pi}{2}$ in Theorem 5.6 is sharp.

PROOF. Let $\theta_j < \theta < \theta^* < \phi_j$. Applying the relations (5.9) and (5.10) and Cauchy's integral theorem and using also the mapping properties of functions in \mathcal{D}_n as described above, we get

$$\begin{aligned} \text{Im } T[f](e^{i\theta}) &= \text{Im} \int_0^{e^{i\theta^*}} \frac{f'(\zeta)}{f(e^{i\theta})} \log \frac{e^{i\theta} f'(\zeta)}{f(e^{i\theta})} d\zeta + \text{Im} \int_{e^{i\theta^*}}^{e^{i\theta}} \frac{f'(\zeta)}{f(e^{i\theta})} \log \frac{e^{i\theta} f'(\zeta)}{f(e^{i\theta})} d\zeta \\ &= \frac{f(e^{i\theta^*})}{f(e^{i\theta})} \int_0^1 \arg \frac{e^{i\theta}}{\gamma'_{\theta^*}(t)} dt + \left(1 - \frac{f(e^{i\theta^*})}{f(e^{i\theta})}\right) \int_0^1 \arg \frac{e^{i\theta}}{\gamma'_{\theta^*, \theta}(t)} dt \\ &= \frac{f(e^{i\theta^*})}{f(e^{i\theta})} \int_0^1 \arg \frac{\gamma'_{\theta^*, \theta}(t)}{\gamma'_{\theta^*}(t)} dt + \int_0^1 \arg \frac{e^{i\theta}}{\gamma'_{\theta^*, \theta}(t)} dt. \end{aligned}$$

Letting $\theta \rightarrow \theta_j$ on both sides of this equation, we obtain

$$\lim_{\theta \rightarrow \theta_j^+} \operatorname{Im} T[f](e^{i\theta}) = \lim_{\theta \rightarrow \theta_j^+} \int_0^1 \arg \frac{e^{i\theta}}{\gamma'_{\theta^*,\theta}(t)} dt \quad (5.11)$$

for all $\theta^* \in (\theta_j, \phi_j)$. For $\theta_j < \theta < \theta^* < \phi_j$ the curve $\gamma_{\theta^*,\theta}$ is one-to-one and maps into the unit circle. Also, $\gamma_{\theta^*,\theta}(0) = e^{i\theta^*}$, $\gamma_{\theta^*,\theta}(1) = e^{i\theta}$ and $\arg \gamma_{\theta^*,\theta}$ is decreasing. Hence, $\theta - \frac{\pi}{2} \leq \arg \gamma'_{\theta^*,\theta}(t) \leq \theta^* - \frac{\pi}{2}$ for $t \in [0, 1]$, and thus, because of (5.11),

$$\theta_j - \theta^* + \frac{\pi}{2} \leq \lim_{\theta \rightarrow \theta_j^+} \operatorname{Im} T[f](e^{i\theta}) \leq \frac{\pi}{2}.$$

Since this holds for all $\theta^* \in (\theta_j, \phi_j)$, we obtain the desired result in the case that $\theta \rightarrow \theta_j^+$.

The second asserted relation can be proved in a similar way. \square

For the proof of Lemma 5.10 we need two more auxiliary results. The first is (a slightly extended version of) the Clunie-Jack lemma [**Jac71**], a consequence of the maximum modulus principle that has already found many other applications; the second is of a purely technical nature.

LEMMA 5.12 (Clunie-Jack). *Let F be an analytic function in \mathbb{D} with $F(0) = 0$. Suppose that F has an analytic extension to a neighborhood N of a point $w \in \mathbb{T} := \{z \in \mathbb{C} : |z| = 1\}$ and that $|F(z)| \leq |F(w)|$ for all $z \in \mathbb{D} \cup (\mathbb{T} \cap N)$. Then $wF'(w)/F(w) \geq 1$.*

LEMMA 5.13. *For all $a \in \mathbb{R}$ and $b \geq \frac{\pi}{2}$ we have*

$$\pi \left(\log \left(b + \frac{\pi}{2} \right) + 1 + a \right) - 2b \left(b + \frac{\pi}{2} \right) \cosh \frac{\pi a}{2b} < 0. \quad (5.12)$$

PROOF. Since $f(b) := \log(b + \frac{\pi}{2})$ is concave, we have

$$f(b) \leq f'(b_0)(b - b_0) + f(b_0)$$

for all $b, b_0 > -\frac{\pi}{2}$. Using this estimate with $b_0 = \frac{\pi}{2}$, we find that for $b \geq \frac{\pi}{2}$

$$\pi \left(\log \left(b + \frac{\pi}{2} \right) + 1 + a \right) - 2b \left(b + \frac{\pi}{2} \right) \cosh \frac{\pi a}{2b} \leq \frac{\pi}{2} + \pi \log \pi + b + \pi a - 2b\pi \cosh \frac{\pi a}{2b}.$$

It will therefore be enough to show that

$$\frac{\pi}{2} + \pi \log \pi < 2b \left(\pi \cosh \frac{\pi a}{2b} - \frac{\pi a}{2b} - \frac{1}{2} \right). \quad (5.13)$$

It is easy to see that

$$\sqrt{1 + \pi^2} - \frac{1}{2} - \operatorname{arsinh} \frac{1}{\pi} > 0$$

is the minimum value of $\pi \cosh(x) - x - \frac{1}{2}$ in \mathbb{R} . Since

$$\pi \left(\sqrt{1 + \pi^2} - \frac{1}{2} - \operatorname{arsinh} \frac{1}{\pi} \right) = 7.80 \dots > 5.17 \dots = \frac{\pi}{2} + \pi \log \pi,$$

(5.13) follows. \square

We can now proceed to the proof of Lemma 5.10.

PROOF OF LEMMA 5.10 AND THEOREM 5.6. Assume Lemma 5.10 is wrong, i.e. assume that there is a $f \in \mathcal{D}_n$ such that $|\operatorname{Im} T[f](e^{is})| > \frac{\pi}{2}$ for a $s \in (\theta_1, \theta_{n+1})$ with

$s \neq \theta_j$. Set $w = e^{is} \in \mathbb{T}$ and $a + ib := T[f](w)$ with $a, b \in \mathbb{R}$. Because of Lemma 5.11 we can assume that s is such that

$$|b| = |\operatorname{Im} T[f](w)| = \max_{z \in \mathbb{D}} |\operatorname{Im} T[f](z)| \geq \frac{\pi}{2} \quad (5.14)$$

and consequently also

$$\operatorname{Im} iwT[f]'(w) = \left. \frac{d}{dt} \operatorname{Im} T[f](e^{it}) \right|_{t=s} = 0. \quad (5.15)$$

By Lemma 5.9 we have $f'(w) \neq 0$ and therefore $T[f]$ has an analytic extension to a neighborhood of w .

Set $r := iw f'(w)/f(w)$ and $\varphi := \arg(-ir)$. Then, because of (5.8), $r \in \mathbb{R}$ and $|\varphi| = \frac{\pi}{2}$. Further, it follows from Lemma 5.9 and (5.14) that $\varphi b < 0$ and thus $|b - \varphi| = \frac{\pi}{2} + |b|$. Taking the imaginary part of (5.5), we get $0 = 1 + r(\varphi - b)$ or $r = 1/(b - \varphi)$ and this, together with (5.5) and (5.15), yields

$$\begin{aligned} \operatorname{sgn}(b)iwT[f]'(w) &= \operatorname{sgn}(b) \operatorname{Re} iwT[f]'(w) \\ &= \operatorname{sgn}(b)r \left(\log \left| \frac{w f'(w)}{f(w)} \right| - 1 - \operatorname{Re} T[f](w) \right) \\ &= -\frac{1}{|b| + \frac{\pi}{2}} \left(\log \left(|b| + \frac{\pi}{2} \right) + 1 + a \right). \end{aligned} \quad (5.16)$$

Observe that $z \mapsto \int_0^z f'(\zeta) \log f'(\zeta) d\zeta$ has at least a double zero at the origin and that $h(z) := f(z)/z$ is analytic at 0 with $h(0) = f'(0) = 1$; hence, we see from the representation (5.4) that $T[f](0) = 0$. Because of this and (5.14) it follows from the mapping properties of the tangent [Neh52, p. 277] that

$$F(z) := \tan \left(\frac{i\pi T[f](z)}{4b} \right), \quad z \in \mathbb{D},$$

is an analytic function in \mathbb{D} with $F(0) = 0$ that has an analytic extension to a neighborhood N of w and satisfies $|F(z)| \leq |F(w)| = 1$ for all $z \in \mathbb{D} \cup (\mathbb{T} \cap N)$. The Clunie-Jack lemma yields that

$$1 \leq \frac{wF'(w)}{F(w)} = \frac{i\pi w T[f]'(w)}{2b \sin(\frac{i\pi}{2b} T[f](w))}. \quad (5.17)$$

Since

$$\sin \frac{i\pi T[f](w)}{2b} = \sin \left(\frac{i\pi a}{2b} - \frac{\pi}{2} \right) = -\cosh \frac{\pi a}{2b},$$

this and (5.16) give

$$1 \leq -\frac{\operatorname{sgn}(b)i\pi w T[f]'(w)}{2|b| \cosh \frac{\pi a}{2|b|}} = \frac{\pi (\log(|b| + \pi/2) + 1 + a)}{2|b|(|b| + \pi/2) \cosh \frac{\pi a}{2|b|}}.$$

But this is impossible for $a \in \mathbb{R}$ and $|b| \geq \frac{\pi}{2}$ by Lemma 5.13.

This completes the proof of Lemma 5.10 and hence Theorem 5.6. \square

5.2. The Set of Starlike Functions Is Starlike

In this section we will show that the class \mathcal{S}^* of starlike functions is starlike in the Hornich space.

The linear structure of \mathcal{S}^* in the Hornich space \mathcal{H} was examined first by Kim, Ponnusamy and Sugawa [KPS04]. They showed that, in contrast to \mathcal{K} and \mathcal{C} (cf. Theorem 5.2), the class \mathcal{S}^* is not convex in \mathcal{H} . However, they were also able to verify

that the straight line $\alpha \odot k = I_\alpha[k]$, $\alpha \in [0, 1]$, between id , the zero element in \mathcal{H} , and the Koebe function $k(z) = z(1-z)^{-2}$ lies completely in \mathcal{S}^* . Since the Koebe function is in many ways extremal in the class \mathcal{S}^* , they went on to pose the following question: Is it true that for all $f \in \mathcal{S}^*$ and $\alpha \in [0, 1]$ one has $I_\alpha[f] \in \mathcal{S}^*$, or, equivalently, is the class \mathcal{S}^* starlike in \mathcal{H} ? In [KPS04] several other results were presented that pointed to a positive answer for this question, but the general problem remained open.

Here we will use Theorem 5.6 in order to show that the answer to the question posed by Kim, Ponnusamy and Sugawa is indeed positive.

THEOREM 5.14. *For all $f \in \mathcal{S}^*$ and $\alpha \in [0, 1]$ we have $I_\alpha[f] \in \mathcal{S}^*$. In other words, the class \mathcal{S}^* of univalent starlike functions is starlike in the Hornich space.*

Because of the definition of starlike functions it is clear that Theorem 5.14 will be proven if we can show that for all $f \in \mathcal{S}^*$, $0 \leq \alpha \leq 1$, and $z \in \mathbb{D}$, we have

$$\operatorname{Re} \frac{I_\alpha[f](z)}{zI_\alpha[f]'(z)} > 0.$$

Denote by \mathcal{S}_c^* the set of functions $f \in \mathcal{S}^*$ that are analytic in a neighborhood of the closed unit disk and by $\mathcal{S}_{c,+}^*$ the set of functions $f \in \mathcal{S}_c^*$ that satisfy $\operatorname{Re} zf'(z)/f(z) > 0$ in $\overline{\mathbb{D}}$. If f is any function in \mathcal{S}^* , then, for $0 < r < 1$, $g(z) := f(rz)/r$ belongs to $\mathcal{S}_{c,+}^*$ and we have

$$\operatorname{Re} \frac{zI_\alpha[g]'(z)}{I_\alpha[g](z)} = \operatorname{Re} \frac{z(g'(z))^\alpha}{\int_0^z (g'(\zeta))^\alpha d\zeta} = \operatorname{Re} \frac{rz(f'(rz))^\alpha}{\int_0^{rz} (f'(\zeta))^\alpha d\zeta} = \operatorname{Re} \frac{rzI_\alpha[f]'(rz)}{I_\alpha[f](rz)}$$

for $z \in \mathbb{D}$, $0 < r < 1$ and $0 \leq \alpha \leq 1$. Therefore we only have to show that Theorem 5.14 is true for functions in the class $\mathcal{S}_{c,+}^*$.

Thus, let $f \in \mathcal{S}_{c,+}^*$. Then there is a $c > 0$ such that $\operatorname{Re} zf'(z)/f(z) > c$ in $\overline{\mathbb{D}}$ and so there must be a $0 \leq \alpha^* < 1$ such that

$$I_\alpha[f] \in \mathcal{S}_{c,+}^* \quad \text{for } \alpha^* < \alpha \leq 1.$$

Suppose that Theorem 5.14 is wrong and that the f we have chosen is a counterexample to it. This means we can assume that $\alpha^* > 0$ is such that $I_\alpha[f] \in \mathcal{S}_{c,+}^*$ for $\alpha^* < \alpha \leq 1$, but that for each $\epsilon > 0$ there is an $\alpha \in (\alpha^* - \epsilon, \alpha^*)$ with $I_\alpha[f] \notin \mathcal{S}_{c,+}^*$. Since \mathcal{S}^* is compact, $I_{\alpha^*}[f]$ must then be a member of \mathcal{S}_c^* and satisfy

$$\operatorname{Re} \frac{wI_{\alpha^*}[f]'(w)}{I_{\alpha^*}[f](w)} = 0 \quad \text{and} \quad I_{\alpha^*}[f]'(w) \neq 0$$

for a w on the unit circle ($f'(w) \neq 0$ obviously implies $I_\alpha[f]'(w) \neq 0$ for $0 \leq \alpha \leq 1$). This, however, is a contradiction to the next lemma since

$$I_\alpha[I_{\alpha^*}[f]] = I_{\alpha\alpha^*}[f] \in \mathcal{S}^*$$

for $1 < \alpha \leq \frac{1}{\alpha^*}$. Theorem 5.14 must therefore be true.

LEMMA 5.15. *Let $f \in \mathcal{S}_c^*$ with $\operatorname{Re} wf'(w)/f(w) = 0$ and $f'(w) \neq 0$ for a $w \in \mathbb{T}$. Then there is an $\alpha^* > 1$ such that $I_\alpha[f] \notin \mathcal{S}^*$ for $1 < \alpha < \alpha^*$.*

PROOF. Since $f'(w) \neq 0$, also $wf'(w)/f(w) \neq 0$ and so

$$\frac{wf'(w)}{f(w)} = i\phi \quad \text{for a } \phi \neq 0.$$

Assume that $\phi > 0$.

To prove the lemma it will clearly be enough to show that

$$\frac{d}{d\alpha} \operatorname{Re} \frac{I_\alpha[f](w)}{wI_\alpha[f]'(w)} \Big|_{\alpha=1} < 0.$$

Now,

$$\begin{aligned} \frac{d}{d\alpha} \operatorname{Re} \frac{I_\alpha[f](w)}{wI_\alpha[f]'(w)} \Big|_{\alpha=1} &= \frac{d}{d\alpha} \operatorname{Re} \int_0^w \frac{1}{w} \left(\frac{f'(\zeta)}{f'(w)} \right)^\alpha d\zeta \Big|_{\alpha=1} \\ &= \operatorname{Re} \int_0^w \frac{f'(\zeta)}{wf'(w)} \log \frac{f'(\zeta)}{f'(w)} d\zeta \\ &= \operatorname{Re} \frac{f(w)}{iwf'(w)} i \left(\int_0^w \frac{f'(\zeta)}{f(w)} \log \frac{wf'(\zeta)}{f(w)} d\zeta - \log \frac{wf'(w)}{f(w)} \right) \\ &= \frac{1}{\phi} \left(\operatorname{Im} T[f](w) - \frac{\pi}{2} \right). \end{aligned}$$

Since it follows readily from Theorem 5.6 and Lemma 5.9 that

$$\operatorname{Im} T[f](w) < \frac{\pi}{2},$$

the lemma is proven in the case $\phi > 0$.

In the case $\phi < 0$ one proceeds in a similar way and therefore the proof is complete. \square

5.3. Functions with Complex Corners

In this section we will use Theorem 5.14 in order to describe a large set of $\alpha \in \mathbb{C}$ for which there is a $f \in \mathcal{S}^*$ such that $I_\alpha[f] \notin \mathcal{S}$. In particular, we will completely determine the set of $\alpha \in \mathbb{R}$ for which $I_\alpha[f] \in \mathcal{S}$ for all $f \in \mathcal{S}^*$. We will also show that the set \mathcal{SP}_β of functions spirallike of order β is not starlike in the Hornich space and prove that Theorem 5.6 is sharp for every subclass \mathcal{S}_α^* , $\alpha \in [0, 1)$, of \mathcal{S}^* .

In [Roy65] Royster completely determined the set of $\mu \in \mathbb{C}$ for which the function $(1-z)^\mu$ is univalent in \mathbb{D} (we consider the branch of the logarithm for which $(1-z)^\mu$ is equal to 1 at $z=0$).

THEOREM 5.16. *The function $(1-z)^\mu$ is univalent in \mathbb{D} if, and only if, $|\mu+1| \leq 1$ or $|\mu-1| \leq 1$.*

We will now show an extension of this result to certain functions $f \in \mathcal{A}$ that behave locally like $(1-z)^\mu$. We will say that a function $f \in \mathcal{A}$ has a corner of order $\mu \in \mathbb{C} \setminus \{0\}$ at $z_0 \in \mathbb{T}$ if there is a constant $d \in \mathbb{C}$ such that $(z_0 - z)^{-\mu}(f(z) - d)$ has an analytic extension to z_0 that does not vanish at z_0 .

THEOREM 5.17. *Let $f \in \mathcal{A}$ have a corner of order $\mu \in \mathbb{C}$ at $z_0 \in \mathbb{T}$. If $\mu \in M := \{\mu : |\mu+1| > 1\} \cap \{\mu : |\mu-1| > 1\}$, then f is not univalent in \mathbb{D} .*

PROOF. It is straightforward to check that $f \in \mathcal{A}$ has a corner of order μ at $z_0 \in \mathbb{T}$ if, and only if, $z_0^{-\mu}f(z_0z) \in \mathcal{A}$ has a corner of order μ at 1 and thus we can suppose that $z_0 = 1$.

Since f has a corner of order μ at 1, there are a $d \in \mathbb{C}$ and a function g that is analytic in a neighborhood N of 1 with $g(1) \neq 0$ such that $f(z) - d = (1-z)^\mu g(z)$ for $z \in \hat{N} := \mathbb{D} \cap N$. We prove the theorem by showing that if $\mu \in M$, then there are two

points $w_1, w_2 \in \mathbb{C}$ with $w_1 - w_2 = 2\pi i$ that lie in the image of \hat{N} under the function $F(z) := H(z) + G(z)$, where

$$H(z) := \mu \log(1 - z) \quad \text{and} \quad G(z) := \log g(z), \quad z \in \hat{N}.$$

Since the desired property holds simultaneously for the functions $F(z)$ and $F(z) - G(1)$, $z \in \hat{N}$, we may assume that $G(1) = 0$.

If $\mu = \rho e^{i\theta} \in M$ with $\rho > 0$ and $\theta \in \mathbb{R}$, then

$$\frac{\rho\pi}{|\cos\theta|} > 2\pi.$$

As described in the proof of the lemma on p. 386 of [Roy65], $H(\mathbb{D})$ is equal to a subset B of a sloping strip S that meets vertical lines in segments of length $\frac{\rho\pi}{|\cos\theta|}$ and the boundary of B approaches one or the other edge of S as the preimage z approaches the point 1 from above or below. Hence, there is an $\epsilon > 0$ such that for every $R > 0$ there are points w_1 and w_2 in B with $|w_j| > R$ and $w_1 - w_2 = 2\pi i$ such that $\text{dist}(w_j, \partial B) > \epsilon$ ($j \in \{1, 2\}$). Since $G(1) = 0$, we can assume that $|G(z)| < \frac{\epsilon}{2}$ for $z \in N$. Let L be a half-plane orthogonal to S such that $B \cap L$ is contained in $H(\hat{N})$ and let $\Gamma \subset \overline{\mathbb{D}} \cup N$ denote the Jordan curve that describes the preimage of $\partial(B \cap L)$ under H . Then we can find $w_1, w_2 \in B \cap L$ with $w_1 - w_2 = 2\pi i$ and $|H(z) - w_j| > \epsilon$ for $j \in \{1, 2\}$ and $z \in \Gamma$. Hence,

$$|G(z)| < \frac{\epsilon}{2} < \epsilon < |H(z) - w_j|$$

for $j \in \{1, 2\}$ and $z \in \Gamma$ and thus it readily follows from Rouché's theorem that there are $z_1, z_2 \in \mathbb{D}$ in the bounded component of $\mathbb{C} \setminus \Gamma$ such that $F(z_j) = w_j$ for $j \in \{1, 2\}$. \square

For every function $f \in \mathcal{S}$ with a non-trivial corner on \mathbb{T} we can now determine a large set of $\alpha \in \mathbb{C}$ such that $I_\alpha[f] \notin \mathcal{S}$.

THEOREM 5.18. *Suppose $f \in \mathcal{S}$ has a corner of order $\mu \in \mathbb{C} \setminus \{0, 1\}$ at $z_0 \in \mathbb{T}$. Then $I_\alpha[f] \notin \mathcal{S}$ if*

$$\alpha = \frac{1}{\mu - 1}(m - 1) \quad \text{for a } m \in M.$$

PROOF. As in the proof of Theorem 5.17 we can assume that $z_0 = 1$. Hence, there is a function g that is analytic in a neighborhood N of 1 with $g(1) \neq 0$ such that

$$f'(z) = (1 - z)^{\mu-1} ((1 - z)g'(z) - \mu g(z))$$

for $z \in \hat{N} := \mathbb{D} \cap N$. The function

$$G(z) := (1 - z)g'(z) - \mu g(z)$$

does not vanish at $z = 1$ and therefore, for each $\alpha \in \mathbb{C} \setminus \{(1 - \mu)^{-1}\}$, there is a sequence $\{a_k\}_{k \in \mathbb{N}_0} \subset \mathbb{C}$ with $a_0 \neq 0$ such that

$$I_\alpha[f]'(z) = (1 - z)^{\alpha(\mu-1)} \sum_{k=0}^{\infty} a_k (1 - z)^k$$

for $z \in \hat{N}$. This shows that both $I_\alpha[f]$ and $(1 - z)^{\alpha(\mu-1)+1} F$, where

$$F(z) := - \sum_{k=0}^{\infty} \frac{a_k}{k + 1 + \alpha(\mu - 1)} (1 - z)^k,$$

are primitives of $I_\alpha[f]'$ in \hat{N} , and thus there is a constant $d \in \mathbb{C}$ such that

$$I_\alpha[f](z) = d + (1 - z)^{\alpha(\mu-1)+1} F(z) \quad \text{for } z \in \hat{N}.$$

Therefore, since $F(1) \neq 0$, $I_\alpha[f]$ has a corner of order $\alpha(\mu-1)+1$ at 1 and the assertion follows from Theorem 5.17. \square

Using this result together with Theorem 5.14, we obtain the following.

COROLLARY 5.19. *Let $\alpha \in \mathbb{C}$ with $|\alpha| > \frac{1}{3}$ and $\alpha \notin [\frac{1}{3}, 1]$. Then there is a function $f \in \mathcal{S}^*$ such that $I_\alpha[f] \notin \mathcal{S}$. In particular, if $\alpha \in \mathbb{R}$, then $I_\alpha[f] \in \mathcal{S}$ for all $f \in \mathcal{S}^*$ if, and only if, $\alpha \in [-\frac{1}{3}, 1]$.*

PROOF. Since the Koebe function $k = z(1-z)^{-2}$ has a corner of order -2 at 1, it follows from Theorem 5.18 that $I_\alpha[k] \notin \mathcal{S}$ if α lies in the complement A of $\{\alpha : |\alpha| < \frac{1}{3}\} \cup \{\alpha : |\alpha - \frac{2}{3}| < \frac{1}{3}\}$. In order to prove that for $\alpha \in B := \{\alpha \notin \mathbb{R} : |\alpha - \frac{2}{3}| < \frac{1}{3}\}$ there is a function $f \in \mathcal{S}^*$ for which $I_\alpha[f] \notin \mathcal{S}$, we adapt the proof of [AN82, Thm. 4]: If $\alpha \in B$, then there is an $\alpha_0 \in A$ with $\arg \alpha = \arg \alpha_0$ and $|\alpha_0| < |\alpha|$. Hence, $\alpha_0/\alpha \in (0, 1)$ and therefore, by Theorem 5.14, $f := I_{\alpha_0/\alpha}[k] \in \mathcal{S}^*$. Now,

$$I_\alpha[f] = I_{\alpha_0}[k] \notin \mathcal{S}$$

since $\alpha_0 \in A$ and thus the first assertion of the corollary is proven.

We have $\mathcal{S}^* \subset \mathcal{C}$ and therefore the second assertion follows from the first and Theorem 5.1 (5). \square

In Lemma 5.11 it was shown that the bound $\frac{\pi}{2}$ in Theorem 5.6 is sharp for the class \mathcal{S}^* . We will now strengthen this result by proving that Theorem 5.6 is sharp for each subclass \mathcal{S}_α^* , $\alpha \in [0, 1)$, of \mathcal{S}^* .

To this end, observe first that for $f_\mu(z) = z(1-z)^{-\mu}$ defined as in Chapter 2 we have

$$\frac{zf'_\mu(z)}{f_\mu(z)} = 1 + \mu \frac{z}{1-z}, \quad z \in \mathbb{D}.$$

Using this relation it is easy to see that for $\mu \in C := \{\mu \in \mathbb{C} \setminus \{0\} : |\mu - 1| \leq 1\}$

$$f_\mu \in \mathcal{SP}_\beta \subset \mathcal{S}, \quad \text{where } \beta = -\arg \mu, \quad (5.18)$$

and

$$\lim_{\theta \rightarrow 0^+} \arg \frac{e^{i\theta} f'_\mu(e^{i\theta})}{f_\mu(e^{i\theta})} = \frac{\pi}{2} + \arg \mu \quad \text{and} \quad \lim_{\theta \rightarrow 0^-} \arg \frac{e^{i\theta} f'_\mu(e^{i\theta})}{f_\mu(e^{i\theta})} = -\frac{\pi}{2} + \arg \mu. \quad (5.19)$$

For $\mu \in C$ we thus obtain

$$\begin{aligned} T[f_\mu](z) &= \log \frac{z}{f_\mu(z)} + \frac{1}{f_\mu(z)} \int_0^z f'_\mu(\zeta) \log f'_\mu(\zeta) d\zeta \\ &= \log \frac{zf'_\mu(z)}{f_\mu(z)} - \frac{1}{f_\mu(z)} \int_0^z \frac{f_\mu(\zeta) f''_\mu(\zeta)}{f'_\mu(\zeta)} d\zeta \\ &= \log \frac{zf'_\mu(z)}{f_\mu(z)} - \frac{1}{f_\mu(z)} \int_0^z \frac{\mu\zeta(2 + (\mu-1)\zeta)}{(1-\zeta)^{\mu+1}(1 + (\mu-1)\zeta)} d\zeta. \end{aligned} \quad (5.20)$$

For $\mu = 1$ or $\mu = 2$ the integral

$$\int_0^z \frac{\mu\zeta(2 + (\mu-1)\zeta)}{(1-\zeta)^{\mu+1}(1 + (\mu-1)\zeta)} d\zeta$$

can be explicitly calculated and doing this we find that for $\mu = 1$ or $\mu = 2$

$$\lim_{\substack{z \rightarrow 1 \\ z \in \mathbb{D} \setminus \{1\}}} \frac{1}{f_\mu(z)} \int_0^z \frac{\mu\zeta(2 + (\mu - 1)\zeta)}{(1 - \zeta)^{\mu+1}(1 + (\mu - 1)\zeta)} d\zeta = \frac{1}{\mu} + 1.$$

In fact, this relation holds for all $\mu \in C$.

LEMMA 5.20. *Let $\mu \in C$. Then*

$$\lim_{\substack{z \rightarrow 1 \\ z \in \mathbb{D} \setminus \{1\}}} \frac{1}{f_\mu(z)} \int_0^z \frac{\mu\zeta(2 + (\mu - 1)\zeta)}{(1 - \zeta)^{\mu+1}(1 + (\mu - 1)\zeta)} d\zeta = \frac{1}{\mu} + 1.$$

PROOF. For $\mu = 1$ or $\mu = 2$ the lemma has already been shown. In the following we will therefore assume that $\mu \in C \setminus \{1, 2\}$.

Since $\operatorname{Re} \mu > 0$, we have

$$\lim_{\substack{z \rightarrow 1 \\ z \in \mathbb{D} \setminus \{1\}}} (1 - z)^\mu = 0, \quad (5.21)$$

and thus

$$\lim_{\substack{z \rightarrow 1 \\ z \in \mathbb{D} \setminus \{1\}}} \frac{\mu z - 1 + (1 - z)^\mu}{(\mu - 1)z} = 1.$$

Therefore, since

$$\begin{aligned} \frac{1}{f_\mu(z)} \int_0^z \frac{\mu\zeta(2 + (\mu - 1)\zeta)}{(1 - \zeta)^{\mu+1}(1 + (\mu - 1)\zeta)} d\zeta &= \\ &= \frac{1}{f_\mu(z)} \int_0^z \frac{\mu\zeta}{(1 - \zeta)^{\mu+1}(1 + (\mu - 1)\zeta)} d\zeta + \frac{\mu z - 1 + (1 - z)^\mu}{(\mu - 1)z}, \end{aligned}$$

only

$$\lim_{\substack{z \rightarrow 1 \\ z \in \mathbb{D} \setminus \{1\}}} \frac{1}{f_\mu(z)} \int_0^z \frac{\mu\zeta}{(1 - \zeta)^{\mu+1}(1 + (\mu - 1)\zeta)} d\zeta = \frac{1}{\mu} \quad (5.22)$$

remains to be verified.

We have

$$\begin{aligned} \frac{1}{f_\mu(z)} \int_0^z \frac{\mu\zeta}{(1 - \zeta)^{\mu+1}(1 + (\mu - 1)\zeta)} d\zeta - \frac{1}{\mu} &= \\ &= \frac{1}{\mu f_\mu(z)} \int_0^z \left(\frac{\mu^2\zeta}{(1 - \zeta)^{\mu+1}(1 + (\mu - 1)\zeta)} - f'_\mu(\zeta) \right) d\zeta \\ &= \frac{1}{\mu f_\mu(z)} \int_0^z \frac{(\mu - 1)^2\zeta - 1}{(1 - \zeta)^\mu(1 + (\mu - 1)\zeta)} d\zeta. \end{aligned}$$

Since $\mu - 1 \neq -1$, there is a neighborhood N of 1 in which the function

$$F(z) := \frac{(\mu - 1)^2\zeta - 1}{1 + (\mu - 1)\zeta}$$

has a power series representation of the form

$$F(z) = \sum_{k=0}^{\infty} a_k(1 - z)^k.$$

It follows that there is a constant $d \in \mathbb{C}$ such that for $z \in N \cap \overline{\mathbb{D}}$ with $z \neq 1$

$$\begin{aligned} \frac{1}{f_\mu(z)} \int_0^z \frac{\mu \zeta}{(1-\zeta)^{\mu+1}(1+(\mu-1)\zeta)} d\zeta - \frac{1}{\mu} &= \\ &= \frac{1}{\mu f_\mu(z)} \left(d - \sum_{k=0}^{\infty} \frac{a_k}{k-\mu+1} (1-z)^{k-\mu+1} \right) \\ &= \frac{1}{\mu z} \left(d(1-z)^\mu - \sum_{k=0}^{\infty} \frac{a_k}{k-\mu+1} (1-z)^{k+1} \right) \end{aligned}$$

and thus (5.22) follows from (5.21). \square

(5.19), (5.20), Lemma 5.20, and the fact that $f_{2-2\lambda} \in \mathcal{S}_\lambda^*$ for all $\lambda \in [0, 1)$, yield the following.

THEOREM 5.21.

(1) *We have*

$$\lim_{\theta \rightarrow 0^+} \operatorname{Im} T[f_\mu](e^{i\theta}) = \frac{\pi}{2} \quad \text{and} \quad \lim_{\theta \rightarrow 0^-} \operatorname{Im} T[f_\mu](e^{i\theta}) = -\frac{\pi}{2}$$

for every $\mu \in (0, 2]$. In particular, Theorem 5.6 is sharp for every subclass \mathcal{S}_λ^* , $\lambda \in [0, 1)$, of \mathcal{S}^* .

(2) *If $\mu = 2e^{-i\beta} \cos \beta$ with $\beta \in (-\frac{\pi}{2}, \frac{\pi}{2})$, then*

$$\lim_{\theta \rightarrow 0^+} \operatorname{Im} T[f_\mu](e^{i\theta}) = \frac{\pi}{2} - \beta - \frac{1}{2} \tan \beta$$

and

$$\lim_{\theta \rightarrow 0^-} \operatorname{Im} T[f_\mu](e^{i\theta}) = -\frac{\pi}{2} - \beta - \frac{1}{2} \tan \beta.$$

The second statement of this theorem can be used to show that, in contrast to \mathcal{S}^* , the classes \mathcal{SP}_β with $\beta \in (-\frac{\pi}{2}, \frac{\pi}{2})$, $\beta \neq 0$, are not starlike in the Hornich space.

THEOREM 5.22. *Let $\beta \in (-\frac{\pi}{2}, \frac{\pi}{2})$ with $\beta \neq 0$. Then the class \mathcal{SP}_β is not starlike in the Hornich space.*

PROOF. Set $\mu := 2e^{-i\beta} \cos \beta$ and write $f = f_\mu$. Then $f_\mu \in \mathcal{SP}_\beta$ and

$$F(z) := e^{i\beta} \frac{zf'(z)}{f(z)} = e^{i\beta} \frac{1 + e^{-2i\beta}z}{1-z}$$

maps the closed unit disk univalently onto the closed right half-plane. In order to prove the theorem it will therefore suffice to find a $z \in \mathbb{T}$ such that

$$\frac{d}{d\alpha} \operatorname{Re} e^{-i\beta} \frac{I_\alpha[f](z)}{zI_\alpha[f]'(z)} \Big|_{\alpha=1} > 0. \quad (5.23)$$

Suppose first that $\beta > 0$. Then, because of Theorem 5.21 (2), we can find a $t \in (2\beta - \pi, 0)$ such that

$$\operatorname{Im} T[f](z) < -\frac{\pi}{2} - \beta. \quad (5.24)$$

for $z = e^{it}$. Since $t \in (2\beta - \pi, 0)$, we have $F(z) = i\phi$ with $\phi < 0$. Hence, as in the proof of Lemma 5.15, we see that

$$\begin{aligned} \frac{d}{d\alpha} \operatorname{Re} e^{-i\beta} \frac{I_\alpha[f](z)}{z I_\alpha[f]'(z)} \Big|_{\alpha=1} &= \operatorname{Re} e^{-i\beta} \frac{f(z)}{izf'(z)} i \left(T[f](z) - \log \frac{zf'(z)}{f(z)} \right) \\ &= \frac{1}{\phi} \left(\operatorname{Im} T[f](z) + \frac{\pi}{2} + \beta \right). \end{aligned}$$

In order to obtain the second identity we have used the fact that $\operatorname{Re} F(e^{it}) = 0$ for $t \in (0, 2\pi)$. Since $\phi < 0$, (5.23) thus follows from (5.24).

The proof of the case $\beta < 0$ is similar and will be omitted. \square

Bibliography

- [AAR99] G.E. Andrews, R. Askey, and R. Roy, *Special functions*, Encyclopedia of Mathematics and its Applications, vol. 71, Cambridge University Press, Cambridge, 1999.
- [ABR01] S. Axler, P. Bourdon, and W. Ramey, *Harmonic function theory*, second ed., Graduate Texts in Mathematics, vol. 137, Springer-Verlag, New York, 2001.
- [AK07] H. Alzer and S. Koumandos, *On a trigonometric sum of Askey and Steinig*, Preprint, 2007.
- [AKL] H. Alzer, S. Koumandos, and M. Lamprecht, *A refinement of Vietoris' inequality for sine polynomials*, Mathematische Nachrichten, accepted.
- [AN82] L.A. Aksent'ev and I.R. Nezhmetdinov, *Sufficient conditions for univalence of certain integral representations*, Trudy Sem. Kraev. Zadacham (1982), no. 18, 3–11, 223.
- [AS65] M. Abramowitz and I.A. Stegun, *Handbook of mathematical functions with formulas, graphs, and mathematical tables*, Dover, New York, 1965.
- [AS74] R. Askey and J. Steinig, *Some positive trigonometric sums*, Trans. Amer. Math. Soc. **187** (1974), 295–307.
- [Ask98] R. Askey, *Vietoris's inequalities and hypergeometric series*, Recent progress in inequalities (Niš, 1996), Math. Appl., vol. 430, Kluwer Acad. Publ., Dordrecht, 1998, pp. 63–76.
- [BDW07] G. Brown, F. Dai, and K. Wang, *Extensions of Vietoris's inequalities. I*, Ramanujan J. **14** (2007), no. 3, 471–507.
- [Bel95] A.S. Belov, *Examples of trigonometric series with nonnegative partial sums*, Mat. Sb. **186** (1995), no. 4, 21–46.
- [BH84] G. Brown and E. Hewitt, *A class of positive trigonometric sums*, Math. Ann. **268** (1984), no. 1, 91–122.
- [Bie60] M. Biernacki, *Sur l'intégrale des fonctions univalentes*, Bull. Acad. Polon. Sci. Sér. Sci. Math. Astr. Phys. **8** (1960), 29–34.
- [BWW93] G. Brown, K.Y. Wang, and D.C. Wilson, *Positivity of some basic cosine sums*, Math. Proc. Cambridge Philos. Soc. **114** (1993), no. 3, 383–391.
- [BY01] G. Brown and Q. Yin, *Positivity of a class of cosine sums*, Acta Sci. Math. (Szeged) **67** (2001), no. 1-2, 221–247.
- [CP70] J.A. Cima and J.A. Pfaltzgraff, *A Banach space of locally univalent functions*, Michigan Math. J. **17** (1970), 321–334.
- [DGM02] U. Daepf, P. Gorkin, and R. Mortini, *Ellipses and finite Blaschke products*, Amer. Math. Monthly **109** (2002), no. 9, 785–795.
- [Dub39] M.J. Dubourdieu, *Sur un théorème de M. S. Bernstein relatif à la transformation de Laplace-Stieltjes*, Compositio Math. **7** (1939), 96–111.
- [Goo53] A.W. Goodman, *The rotation theorem for starlike univalent functions*, Proc. Amer. Math. Soc. **4** (1953), 278–286.
- [Goo83] ———, *Univalent functions. Vol. I*, Mariner Publishing Co. Inc., Tampa, FL, 1983.
- [GQ09] B.-N. Guo and F. Qi, *Properties and applications of a function involving exponential functions*, Commun. Pure Appl. Anal. **8** (2009), no. 4, 1231–1249.
- [Gra02] J.H. Grace, *The zeros of a polynomial*, Proc. Cambridge Phil. Soc. **11** (1900–1902), 352–357.
- [Grö12] T.H. Grönwall, *Über die Gibbssche Erscheinung und die trigonometrischen Summen $\sin x + \frac{1}{2} \sin 2x + \dots + \frac{1}{n} \sin nx$* , Math. Ann. **72** (1912), 228–243.
- [Hor69] H. Hornich, *Ein Banachraum analytischer Funktionen in Zusammenhang mit den schlichten Funktionen*, Monatsh. Math. **73** (1969), 36–45.
- [Jac11] D. Jackson, *Über eine trigonometrische Summe*, Rend. Circ. Mat. Palermo **32** (1911), 257–262.
- [Jac71] I.S. Jack, *Functions starlike and convex of order α* , J. London Math. Soc. (2) **3** (1971), 469–474.

- [JP08] M. Jarnicki and P. Pflug, *First steps in several complex variables: Reinhardt domains*, EMS Textbooks in Mathematics, European Mathematical Society (EMS), Zürich, 2008.
- [ket] *Ketpic for maple*, Available online at www.kisarazu.ac.jp/~masa/math/.
- [KL63] J. Krzyż and Z. Lewandowski, *On the integral of univalent functions*, Bull. Acad. Polon. Sci. Sér. Sci. Math. Astronom. Phys. **11** (1963), 447–448.
- [KL09a] S. Koumandos and M. Lamprecht, *On a conjecture for trigonometric sums and starlike functions II*, J. Approx. Theory (2009), DOI: 10.1016/j.jat.2009.11.007.
- [KL09b] ———, *Some completely monotonic functions of positive order*, Math. Comp. (2009), DOI: 10.1090/S0025-5718-09-02313-8.
- [KM72] Y.J. Kim and E.P. Merkes, *On an integral of powers of a spirallike function*, Kyungpook Math. J. **12** (1972), 249–252.
- [KM74] ———, *On certain convex sets in the space of locally schlicht functions*, Trans. Amer. Math. Soc. **196** (1974), 217–224.
- [Kou07] S. Koumandos, *An extension of Vietoris’s inequalities*, Ramanujan J. **14** (2007), no. 1, 1–38.
- [Kou08] ———, *Monotonicity of some functions involving the gamma and psi functions*, Math. Comp. **77** (2008), no. 264, 2261–2275.
- [KP02] S.G. Krantz and H.R. Parks, *A primer of real analytic functions*, second ed., Birkhäuser Advanced Texts: Basler Lehrbücher. [Birkhäuser Advanced Texts: Basel Textbooks], Birkhäuser Boston Inc., Boston, MA, 2002.
- [KP09] S. Koumandos and H.L. Pedersen, *Completely monotonic functions of positive order and asymptotic expansions of the logarithm of Barnes double gamma function and Euler’s gamma function*, J. Math. Anal. Appl. **355** (2009), no. 1, 33–40.
- [KPS04] Y.C. Kim, S. Ponnusamy, and T. Sugawa, *Mapping properties of nonlinear integral operators and pre-Schwarzian derivatives*, J. Math. Anal. Appl. **299** (2004), no. 2, 433–447.
- [KR06] S. Koumandos and S. Ruscheweyh, *Positive Gegenbauer polynomial sums and applications to starlike functions*, Constr. Approx. **23** (2006), no. 2, 197–210.
- [KR07] ———, *On a conjecture for trigonometric sums and starlike functions*, J. Approx. Theory **149** (2007), no. 1, 42–58.
- [Lam05] M. Lamprecht, *A generalization of Grace’s theorem*, Master’s thesis, Universität Würzburg, 2005, electronic copy available from the author.
- [Lam07] ———, *Starlike functions in the Hornich space*, Comput. Methods Funct. Theory **7** (2007), no. 2, 573–582.
- [Lam10] ———, *An extension of Suffridge’s convolution theorem*, J. Math. Anal. Appl. (2010), DOI:10.1016/j.jmaa.2010.01.004.
- [Mer] E.P. Merkes, *Univalence of an integral transform*, Topics in complex analysis (Fairfield, Conn., 1983), Contemp. Math., vol. 38, pp. 113–119.
- [MW71] E.P. Merkes and D.J. Wright, *On the univalence of a certain integral*, Proc. Amer. Math. Soc. **27** (1971), 97–100.
- [Neh52] Z. Nehari, *Conformal mapping*, McGraw-Hill Book Co., Inc., New York, Toronto, London, 1952.
- [Pfa75] J.A. Pfaltzgraff, *Univalence of the integral of $f'(z)^\lambda$* , Bull. London Math. Soc. **7** (1975), no. 3, 254–256.
- [PS58] G. Pólya and I.J. Schoenberg, *Remarks on de la Vallée Poussin means and convex conformal maps of the circle*, Pacific J. Math. **8** (1958), 295–334.
- [Roy65] W.C. Royster, *On the univalence of a certain integral*, Michigan Math. J. **12** (1965), 385–387.
- [RS00] S. Ruscheweyh and L. Salinas, *On starlike functions of order $\lambda \in [\frac{1}{2}, 1)$* , Ann. Univ. Mariae Curie-Skłodowska Sect. A **54** (2000), 117–123.
- [RS02] Q.I. Rahman and G. Schmeisser, *Analytic theory of polynomials*, London Mathematical Society Monographs. New Series, vol. 26, The Clarendon Press Oxford University Press, Oxford, 2002.
- [RS04] S. Ruscheweyh and L. Salinas, *Stable functions and Vietoris’ theorem*, J. Math. Anal. Appl. **291** (2004), no. 2, 596–604.
- [RS09] ———, *Universally prestarlike functions as convolution multipliers*, Math. Z. **263** (2009), no. 3, 607–617.

- [RS10] ———, *New Pólya-Schoenberg type theorems*, J. Math. Anal. Appl. **363** (2010), no. 2, 481–496.
- [RSS73] S. Ruscheweyh and T. Sheil-Small, *Hadamard products of Schlicht functions and the Pólya-Schoenberg conjecture*, Comment. Math. Helv. **48** (1973), 119–135.
- [RSS09] S. Ruscheweyh, L. Salinas, and T. Sugawa, *Completely monotone sequences and universally prestarlike functions*, Israel J. Math. **171** (2009), no. 1, 285–304.
- [Rus78] S. Ruscheweyh, *On the Kakeya-Eneström theorem and Gegenbauer polynomial sums*, SIAM J. Math. Anal. **9** (1978), no. 4, 682–686.
- [Rus82] ———, *Convolutions in geometric function theory*, Séminaire de Mathématiques Supérieures [Seminar on Higher Mathematics], vol. 83, Presses de l'Université de Montréal, Montréal, Que., 1982, Fundamental Theories of Physics.
- [Rus87] ———, *Coefficient conditions for starlike functions*, Glasgow Math. J. **29** (1987), no. 1, 141–142.
- [SS02] T. Sheil-Small, *Complex polynomials*, Cambridge Studies in Advanced Mathematics, vol. 75, Cambridge University Press, Cambridge, 2002.
- [Suf76] T.J. Suffridge, *Starlike functions as limits of polynomials*, Advances in complex function theory (Proc. Sem., Univ. Maryland, College Park, Md., 1973–1974), Springer, Berlin, 1976, pp. 164–203. Lecture Notes in Math., Vol. 505.
- [Sze22] G. Szegő, *Bemerkungen zu einem Satz von J. H. Grace über die Wurzeln algebraischer Gleichungen.*, Math. Zeitschr. **13** (1922), 28–55.
- [TWW89] S.Y. Trimble, J. Wells, and F. T. Wright, *Superadditive functions and a statistical application*, SIAM J. Math. Anal. **20** (1989), no. 5, 1255–1259.
- [vH96] H. van Haeringen, *Completely monotonic and related functions*, J. Math. Anal. Appl. **204** (1996), no. 2, 389–408.
- [Vie58] L. Vietoris, *Über das Vorzeichen gewisser trigonometrischer Summen*, S.-B. Öster. Akad. Wiss. **167** (1958), 125–135.
- [Vie59] ———, *Über das Vorzeichen gewisser trigonometrischer Summen II*, Anz. Öster. Akad. Wiss. **167** (1959), 192–193.
- [Wid41] D.V. Widder, *The Laplace Transform*, Princeton Mathematical Series, v. 6, Princeton University Press, Princeton, N. J., 1941.
- [You13] W.H. Young, *On a certain series of Fourier*, Proc. London Math. Soc. **11** (1913), 357–366.
- [Zyg02] A. Zygmund, *Trigonometric series. Vol. I, II*, third ed., Cambridge Mathematical Library, Cambridge University Press, Cambridge, 2002, With a foreword by Robert A. Fefferman.