

RESEARCH IN MATHEMATICS EDUCATION

Editor
Athanasios Gagatsis

CONFERENCE OF FIVE CITIES: NICOSIA, RHODES, BOLOGNA,
PALERMO, LOCARNO



University
of Cyprus

SCHOOL OF SOCIAL SCIENCES AND SCIENCES OF
EDUCATION
Nicosia - Cyprus, 2008

“Research in Mathematics Education”

Scientific Committee

Athanasios Gagatsis, University of Cyprus

Evgenios Avgerinos, University of the Aegean

Bruno D’Amore, University of Bologna

Filippo Spagnolo, University of Palermo

Silvia Sbaragli, ASP Pedagogical High School, Locarno

Editing assistance:

Annita Monoyiou

Andreas Philippou

Simoni Symeonidou

Nicosia – Cyprus, 2008

ISBN: 978-9963-8850-8-4

RESEARCH IN MATHEMATICS EDUCATION

Editor
Athanasios Gagatsis

CONFERENCE OF FIVE CITIES: NICOSIA, RHODES, BOLOGNA,
PALERMO, LOCARNO



SCHOOL OF SOCIAL SCIENCES AND SCIENCES OF
EDUCATION

A Book on the Occasion of the Conference of Five Cities

This book was published on the occasion of the “Conference of Five Cities” which was the first in a series of conferences on Research in Mathematics Education. In the following years the conferences will be organized in turn, in four Greek- and Italian-speaking cities: Rhodes, Bologna, Palermo and Locarno.

The first conference took place at the University of Cyprus in Nicosia (Cyprus), from the 13th until the 14th of September, 2008. It was organized with great success by the University of Cyprus, University of the Aegean, University of Bologna, University of Palermo and ASP Pedagogical High School, Locarno, in cooperation with the Cyprus Mathematical Society.

The core of this book is based on a selection of papers presented at the “Conference of Five Cities” while some of the articles included were not presented at the conference. The main aim of this publication is to promote research in mathematics education. The contributions in this book are interesting, stimulation and thoughtful and will give the reader insight into research in the area of mathematics education.

New directions in research are presented in the six chapters of the book which cover a variety of topics such as, representations and visualization, teaching and learning of geometry, proportionality and pseudo-proportionality, problem solving, the history and philosophy of mathematics and teaching and learning in mathematics.

This book provides avenues to engage mathematics education researchers, teachers and prospective teachers in critical and productive discussions about specific mathematical topics not only in the five cities mentioned above but in all Europe.

Athanasios Gagatsis

Professor in Mathematics Education

Dean, School of Social Sciences and Sciences of Education

University of Cyprus

CONTENTS

CHAPTER 1: Representations and Visualization in Mathematics Education

The stability of students' approaches in function problem solving: A coordinated and an algebraic approach

Annita Monoyiou and Athanasios Gagatsis 3

The phenomenon of change of the meaning of mathematical objects due to the passage between their different representations: How other disciplines can be useful to the analysis

Bruno D'Amore and Martha Isabel Fandiño Pinilla 13

The structure of fraction addition understanding: A comparison between the hierarchical clustering of variables, implicative statistical analysis and confirmatory factor analysis

Eleni Deliyianni, Iliada Elia, Athanasios Gagatsis and Areti Panaoura 23

The role of verbal description, representational and decorative picture in mathematical problem solving

Sofia Agathangelou, Athanasios Gagatsis and Veronika Papakosta 39

Misconceptions and Semiotics: A comparison

George Santi and Silvia Sbaragli 57

Greek students ability in statistical problem solving: A multilevel statistical analysis

Sofia Anastasiadou 73

Fractions, decimal numbers and their representations: A research in 5th and 6th grade of elementary school

Anna Menelaou, Athanasios Gagatsis and Sergios Sergiou 85

CHAPTER 2: Teaching and Learning of Geometry

Spatial abilities in relation to performance in items involving net-representations of geometrical solids

Georgia Panaoura and Athanasios Gagatsis 101

Students' motivational beliefs, metacognitive strategies and the ability to solve volume problems in different representations

Paraskevi Sophocleous, Eleni Michael and Athanasios Gagatsis 115

Investigating the structures of students' geometrical performance

Georgia Panaoura and Athanasios Gagatsis 131

CHAPTER 3: Proportionality and pseudo-proportionality

Proportional reasoning in elementary and secondary education: Moving beyond the percentages

Modestina Modestou and Athanasios Gagatsis 147

Prospective teachers' application of the mathematical concept of proportion in real life situations

Charalambos Lemonidis 163

CHAPTER 4: Problem Solving in Mathematics Education

An ICT environment to assess and support students' mathematical problem-solving performance in non-routine puzzle-like word problems

Angeliki Kolovou, Marja van den Heuvel-Panhuizen, Arthur Bakker and Iliada Elia 175

Approaching the inequality concept via a functional approach to school algebra in a problem solving context

Petros Verikios and Vassiliki Farmaki 191

CHAPTER 5: History and Philosophy of Mathematics

The anthyphairetic interpretation of Zeno's fragments B2, B1 and B3

Stylios Negrepontis and Ioannis Salonikides 209

‘Representation *per se*’ vs. ‘Representation as’, a useful Distinction for Mathematics Education

Demetris Portides 227

Different procedures in argumentation and conjecturation in primary school: An experience with Chinese students

Benedetto Di Paola and Filippo Spagnolo 235

Approaching mathematics through history and culture: A suggestion

Ioanna Georgiou 253

CHAPTER 6: Mathematics Education and Topics in Teaching Mathematics

Is it possible to communicate mathematical meaning? – Epistemological analysis of interactive meaning construction in the classroom

Heinz Steinbring 267

Fuzziness, or probability in the process of learning?
A general question illustrated by examples from teaching mathematics

Michael Gr. Voskoglou 275

How can mathematics reach children with learning difficulties?

Simoni Symeonidou 285

CHAPTER 1

Representations and Visualization in Mathematics Education



The stability of students' approaches in function problem solving: A coordinated and an algebraic approach

Annita Monoyiou & Athanasios Gagatsis

Department of Education, University of Cyprus

Abstract

The aim of this study was twofold. First to contribute to the understanding of the algebraic and "coordinated" approaches teachers develop in solving function tasks and to examine which approach is more correlated with teachers' ability in problem solving. Secondly, to investigate the stability of these approaches and to examine the impact teachers' mathematical background has on them. The study was conducted in two phases. Participants were 288 pre service teachers. Results were similar in both phases, indicating the stability of teachers' approaches and providing support for their intention to use the algebraic approach. Teachers who were able to use the coordinated approach had better results in problem solving. Teachers who dealt with mathematics systematically used more often the coordinated approach.

Introduction and theoretical framework

The concept of function is central in mathematics and its applications. The understanding of functions does not appear to be easy. Students of secondary or even tertiary education, in any country, have difficulties in conceptualizing the notion of function. A factor that influences the learning of functions is the diversity of representations related to this concept (Hitt, 1998). An important educational objective in mathematics is for pupils to identify and use efficiently various forms of representation of the same mathematical concept and move flexibly from one system of representation of the concept to another.

The use of multiple representations has been strongly connected with the complex process of learning in mathematics, and more particularly, with the seeking of students' better understanding of important mathematical concepts (Greeno & Hall, 1997), such as function. The ability to identify and represent the same concept through different representations is considered as a prerequisite for the understanding of the particular concept (Duval, 2002; Even, 1998). Some researchers interpret students' errors as either a product of a deficient handling of representations or a lack of coordination between representations (Greeno & Hall, 1997). The standard representational forms of some

mathematical concepts, such as the concept of function, are not enough for students to construct the whole meaning and grasp the whole range of their applications. Mathematics instructors, at the secondary level, traditionally have focused their teaching on the use of the algebraic representation of functions (Eisenberg & Dreyfus, 1991). Sfard (1992) showed that students were unable to bridge the algebraic and graphical representations of functions, while Markovits, Eylon and Bruckheimer (1986) observed that the translation from graphical to algebraic form was more difficult than the reverse.

The theoretical perspective used in this study is mainly based on the studies of Even (1998) and Mousoulides and Gagatsis (2004). Even (1998) focused on the intertwining between the flexibility in moving from one representation to another and other aspects of knowledge and understanding. This study indicated that subjects had difficulties when they needed to flexibly link different representations of functions. An important finding was that many students deal with functions pointwise (they can plot and read points) but cannot think of a function in a global way. The data also suggested that subjects who can easily and freely use a global analysis of changes in the graphical representation have a better and more powerful understanding of the relationships between graphical and symbolic representations than people who prefer to check some local and specific characteristics.

Mousoulides and Gagatsis (2004) investigated students' performance in mathematical activities that involved principally the conversion between systems of representation of the same function, and concentrated on students' approaches as regards the use of representations of functions and their connection with students' problem solving processes. The most important finding of this study was that two distinct groups were formed with consistency, that is, the algebraic and the geometric approach group. The majority of students' work with functions was restricted to the domain of algebraic approach. Only a few students used an object perspective and approached a function holistically, as an entity. Students who had a coherent understanding of the concept of functions (geometric approach) could easily understand the relationships between symbolic and graphical representations in problems.

In this study the concept of function is viewed from two different perspectives, the algebraic and the coordinated perspective. The algebraic perspective is similar to the pointwise approach described by Even (1998) and the one described by Mousoulides and Gagatsis (2004). In this perspective, a function is perceived of as linking x and y values. The coordinated perspective combines the algebraic and the graphical approach. In this perspective, the function is thought from a local and a global point of view at the same time. The students' can "coordinate" (flexibly manipulate) two systems of representation, the algebraic and the graphical one.

The purpose of this study is to contribute to the understanding of the algebraic and coordinated approaches teachers develop and use in solving function tasks and to examine which approach is more correlated with teachers' ability in solving complex

problems. Furthermore, this research study aims to investigate the stability of teachers' approaches and to examine the impact teachers' mathematical education in high school has on them.

Method

The study was conducted in two phases. The first phase was conducted in 2005 with 135 participants and the second phase was conducted two years later, in 2007, with 153 participants. The participants of the second phase graduated from a slightly different type of high school with different textbooks and different procedures for the selection of lessons as a result of the major changes happened in the educational system, at high school. The participants, in both phases, were pre service teachers. The subjects were for the most part students of high academic performance admitted to the University of Cyprus on the basis of competitive examination scores. Nevertheless there are big differences among them concerning their mathematical education in high school. More specifically, 122 of them dealt with mathematics systematically in high school (Mathematics group). In contrast, the other 166 teachers did not have a special interest or specialization on mathematics and in high school they dealt systematically with theoretical lessons such as history (Theoretical group).

A test was administrated to all the participants. The test consisted of seven tasks. The first four tasks were simple tasks with functions (T1a, T1c, T2a, T2c, T3a, T3c, T4a, T4c). In each task, there were two linear or quadratic functions. Both functions were in algebraic form and one of them was also in graphical representation. There was always a relation between the two functions (e.g. $f(x)=2x$, $g(x)=2x+1$). The participants were asked to interpret graphically the second function. The other three tasks were complex problems. The first problem consisted of textual information about a tank containing an initial amount of petrol (600 L) and a tank car filling the tank with petrol. The tank car contains 2000 L of petrol and the rate of filling is 100 L per minute. Students were asked to use the information in order to give the two equations (Pr1a), to draw the graphs of the two linear functions (Pr1b) and to find when the amounts of petrol in the tank and in the car would be equal (Pr1c). The second problem consisted of textual and algebraic information about an ant colony. The number of ants (A) increases according to the function: $A=t^2+1000$ (t = the number of days). The amount of seeds, the ants save in the colony, increases according to the function $S=3t+3000$ (t = the number of days). Students were asked to use the information in order to draw the graphs (Pr2a) of the quadratic and linear functions and to find when the number of ants in the colony and the number of seeds would be equal (Pr2b). The third problem consisted of a function in a general form of $f(x) = ax^2+bx+c$. Numbers a , b and c were real numbers and the $f(x)$ was equal to 4 when $x=2$ and $f(x)$ was equal to -6 when $x=7$. Students were asked to find how many real solutions the equation ax^2+bx+c had and explain their answer (Pr3). The test was administered to students in a 60 minutes session.

The results concerning students' answers to the four tasks were codified by an uppercase T (task), followed by the number indicating the exercise number. Following

is the letter that signifies the way students solved the task: (a) “a” was used to represent “algebraic approach – function as a process” to the tasks, (b) “c” stands for students who adopted a “coordinated approach – function as an entity”. A solution was coded as “algebraic” if students did not use the information provided by the graph of the first function and they proceeded constructing the graph of the second function by finding pairs of values for x and y . On the contrary, a solution was coded as coordinated if students observed and used the relation between the two functions in constructing the graph of the second function. In this case students used and coordinated two systems of representation. They noticed the relationship between the two equations given and they interpreted this relationship graphically by manipulating the function as an entity. The following symbols were used to represent students’ solutions to the problems: Pr1a, Pr1b, Pr1c, Pr2a, Pr2b and Pr3. Right and wrong answers to the problems were scored as 1 and 0, respectively.

For the analysis of the collected data the similarity statistical method was conducted using a computer software called C.H.I.C. Two similarity diagrams of teachers’ responses, one for each phase, were constructed (Gras, Peter, Briand, & Philippe, 1997). In order to examine whether there are statistically significant differences between the teachers of phase A and B and to determine whether teachers’ mathematical education in high school affect the approach they used and their performance in problem solving, multivariate analysis of variance (MANOVA) was performed by using SPSS.

Results

The main purpose of the present study was to examine the mode of approach pre service teachers, participating in phase A and B, used in solving simple tasks in functions and to investigate which approach is more correlated with solving complex mathematical problems. Table 1, shows teachers’ responses to the first four tasks. According to Table 1, most of the teachers, participating in both phases, solved correctly Task 1 and 2.

Task 1 involved a linear function and Task 2 the simplest form of an equation of a parabola ($y=x^2$). Their achievement radically reduced in tasks involved “complex” quadratic functions (T3 and T4). More than half of the teachers chose an algebraic approach to solve the first three tasks. In Task 4 most of the teachers chose a coordinated approach. In this task a coordinated approach seemed easier and more efficient than the algebraic. The teachers participating in both phases gave quite similar responses to the four tasks. The only difference was that the teachers of phase B used less the coordinated approach and gave more incorrect responses than teachers of phase A.

In the case of Task 1 ($y=2x$, $y=2x+1$), some teachers who used an algebraic approach found the points of intersection with x and y axis and constructed the graph. Others constructed a table of values in order to help them construct the graph. The teachers who used a coordinated approach compared the two equations and mentioned that the slope was the same and the two functions are parallel. Then they referred to the fact that

A coordinated and an algebraic approach in function problem solving

the points of the second function are “one more” than the points of the other. Some of them found a point in order to verify their assertion.

Table 1: Teachers’ responses to the first four tasks (Phase A and B)

Tasks (%)	Algebraic approach with correct answer	Coordinated approach with correct answer	Incorrect answer	
1	A	54.8	32.5	12.7
	B	56.2	22.2	21.6
2	A	54.8	31.1	14.1
	B	56.9	25.5	17.6
3	A	56.3	17.7	26
	B	43.8	15	41.2
4	A	24.4	48.1	27.5
	B	24.8	47.1	28.1

In the case of Tasks 2 ($y=x^2$, $y=x^2-1$) and 3 ($y=x^2+3x$, $y=x^2+3x+2$), teachers who used an algebraic approach found the real solutions of the second equation and the minimum point and constructed the graph without using the first graph. In contrast, teachers who used a coordinated approach first compared the two equations and realized that they are parallel. Then they mentioned that the minimum point in the first case is “one down” and in the second case “two above”. Some of them found another point in order to draw the graph more precise. In the case of Task 4 ($y=3x^2+2x+1$, $y=-(3x^2+2x+1)$), the teachers who used an algebraic approach found the point of intersection with y-axis and the maximum point. The participants who used a coordinated approach compared the two equations and mentioned that the two functions are “opposite” and “symmetrical” to the x-axis. In this task, an algebraic approach was more complicated due to the fact that the equation does not have real solutions. Most of the teachers, after an unsuccessful effort to find the points of section with x-axis drew the graph using a coordinated approach.

Table 2 shows teachers’ responses to complex problems. Teachers’ performance was moderate. In Problem 1 only 38.5% of the phase A teachers and 22.9% of the phase B teachers managed to use the information given in order to give the two equations. A larger percentage constructed the two graphs correctly (59.2% and 45.8% respectively) and found their point of intersection (70.4% and 55.6%). Many teachers were unable to give the equations but manage to construct the graphs by constructing a table of values for x and y. Some of the teachers did not construct the graphs but found their point of intersection by using the table of values. In Problem 2 only 46.6% of the phase A and

35.3% of the phase B teachers managed to construct the graphs. A smaller percentage (35.5% and 27.5%) found their point of intersection. In this problem in order to find the point of intersection the teachers had to solve a second degree equation and that caused difficulties. Problem 3 was quite difficult for the teachers of both phases since only 37% and 20.3% respectively managed to solve it correctly. The teachers participating in phase A performed better than the teachers of phase B.

Table 2: Teachers' responses to the complex problems (Phase A and B)

Problems (%)		Correct answer	Incorrect answer
1a	A	38.5	61.5
	B	22.9	77.1
1b	A	59.2	40.8
	B	45.8	54.2
1c	A	70.4	29.6
	B	55.6	44.4
2a	A	46.6	53.4
	B	35.3	64.7
2b	A	35.5	64.5
	B	27.5	72.5
3	A	37	63
	B	20.3	79.7

In order to examine whether there are statistically significant differences between the teachers of phase A and B concerning the approach they used and their problem solving ability, a multivariate analysis of variance (MANOVA) was performed. Overall, the effects of teachers' phase were significant (Pillai's $F(3, 284) = 3.66, p < 0.05$). Particularly, there were significant differences between the two phases concerning the effectiveness in problem solving ($F(1, 284) = 10.11, p < 0.05$). There were not statistically significant differences between the teachers of phase A and B concerning the algebraic ($F(1, 284) = 0.25, p = 0.62$) and coordinated approach ($F(1, 284) = 1.43, p = 0.23$). Specifically, the teachers of phase A ($\bar{X} = 2.87, SD = 2.24$) performed better than the teachers of phase B in problem solving ($\bar{X} = 2.07, SD = 2.04$).

Teachers' (participating in phases A and B) correct responses to the tasks and problems are presented in the similarity diagrams in Figure 1 and 2 respectively. The two similarity diagrams are quite similar. More specifically in both diagrams, two clusters (i.e., groups of variables) can be distinctively identified. The first cluster consists of the variables "T1c", "T2c", "T3c", "T4c", "Pr1a", "Pr1b", "Pr1c", "Pr3", "Pr2a" and "Pr2b"

and refers to the use of the coordinated approach and the solving of problems. The second cluster consists of the variables “T1a”, “T2a”, “T3a” and “T4a” which represent the use of algebraic approach.

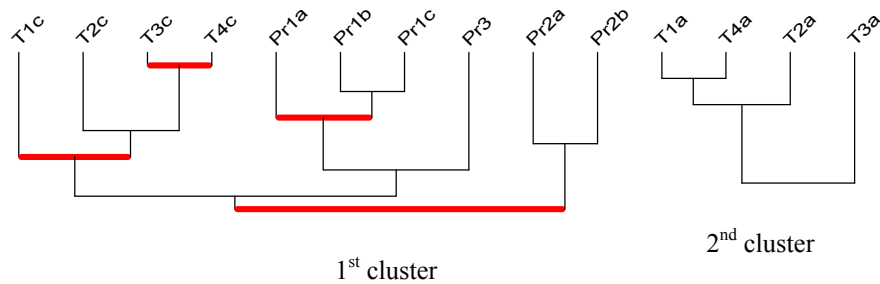

Figure 1: Similarity diagram of teachers' participating in phase A responses

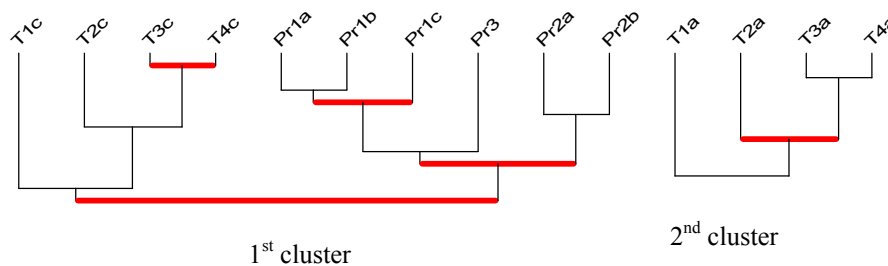

Figure 2: Similarity diagram of teachers' participating in phase B responses

From the similarity diagrams it can be observed that the first cluster includes the variables corresponding to the solution of the complex problems with the variables representing the coordinated approach. More specifically, teachers' coordinated approach to simple tasks in functions is closely related with effectiveness in solving problems. This close connection may indicate that teachers, who can use effectively different types of representation- in this situation both algebraic and graphical representation- are able to observe the connections and relations in problems, and are more capable in problem solving. It is noteworthy the fact that the similarity clusters presented in the two diagrams are almost the same indicating that the connections and relationships between the approaches and problem solving are very strong and long-lasting. The first cluster of both groups is exactly the same, while the second cluster although it contains the same variables it presents small differences concerning the relations between the tasks. Thus, the highest similarity in 2nd cluster, in phase B, concerns the tasks T3a and T4a that are the most complex as it has been noticed previously.

In order to determine whether there are significant differences between the two groups (Mathematics and Theoretical Group) concerning the approach they used and their performance in problem solving, a multivariate analysis of variance (MANOVA) was performed. Overall, the effects of teachers' mathematical education in high school were significant (Pillai's $F(3, 284) = 65.78, p < 0.001$). Particularly, the mean value of the Mathematics group concerning the coordinated approach ($\bar{X} = 1.93, SD = 1.54$) was statistically significant higher ($F(1, 284) = 116.99, p < 0.001$) than the mean value of the Theoretical group ($\bar{X} = 0.64, SD = 0.98$). In contrast, the mean value of the Mathematics group concerning the algebraic approach ($\bar{X} = 1.83, SD = 1.46$) was lower than the mean value of the Theoretical group ($\bar{X} = 1.88, SD = 1.47$) but this difference was not statistically significant ($F(1, 284) = 0.087, p = 0.78$). As far as the problem solving concerns the Mathematics group ($\bar{X} = 3.97, SD = 1.94$) outperformed the Theoretical group ($\bar{X} = 1.33, SD = 1.57$) and this difference was statistically significant ($F(1, 284) = 488.57, p < 0.001$). The Mathematics group used more often the coordinated approach and had also better results in problem solving.

Discussion

A main question of this study referred to the approach teachers use in order to solve simple function tasks. It is important to know whether teachers are flexible in using algebraic and graphical representations in function problems. Most of the teachers, participating in phase A and B, used an algebraic approach in order to solve the simple function tasks. A coordinated approach is fundamental in solving problems even though many students have not mastered even the fundamentals of this approach. This finding is in line with the results of other studies that suggest that many students deal with functions pointwise, although a global approach is more powerful (Even 1998). Students who can easily and freely use a global approach have a better and more powerful understanding of the relationships between graphical and algebraic representations and are more successful in problem solving. Students' preference in the algebraic solution is probably the curricular and instructional emphasis dominated by a focus on algebraic representations and their manipulation.

Teachers' performance in problem solving was moderate. Teachers participating in phase A performed better than teachers of phase B. Although problems used in this study are some of those taught at school, subjects had difficulties. This finding suggests that in order to give a correct solution to a complex function problem the students must be able to handle different representations of function flexibly and move easily from one representation to the other. Furthermore, an important finding of this study is the relation between the coordinated approach and the problem solving. The data from both phases suggest that students who have a coherent understanding of the concept of function (coordinated approach) can easily understand the relationships between symbolic and graphical representations and therefore are able to provide successful solutions to complex problems. Furthermore, it is noteworthy that this close relationship

between the coordinated approach and problem solving ability is strong and stable. Although the second phase conducted two years later and major changes have happened in the educational system, teachers' approaches were the same and a strong relationship between the coordinated approach and problem solving ability still existed. The only difference between the two phases was the effectiveness in problem solving. The teachers participating in phase A performed better than teachers participating in phase B. This difference is probably the result of the major changes happened in high school.

Although all the participants of this study were pre service teachers they had many differences concerning their mathematical education in high school. Some of the students had dealt with mathematics systematically in high school (Mathematics group). The Mathematics group used more often the coordinated approach to solve the simple tasks. Furthermore, they were able to use an algebraic and a graphical representation at the same time and therefore were very successful in problem solving. It's obvious that the students who dealt with mathematics systematically in high school had developed a conceptual understanding of the concept of function. They were able to handle different representations of the concept, easy translate one representation to the other and as a consequence they were more successful in problem solving.

References

- Duval, R. (2002). The cognitive analysis of problems of comprehension in the learning of mathematics. *Mediterranean Journal for Research in Mathematics Education*, 1(2), 1-16.
- Eisenberg, T., & Dreyfus, T. (1991). On the reluctance to visualize in mathematics. In W. Zimmermann & S. Cunningham (Eds.), *Visualization in Teaching and Learning Mathematics* (pp. 9-24). United States: Mathematical Association of America.
- Even, R. (1998). Factors involved in linking representations of functions. *The Journal of Mathematical Behavior*, 17(1), 105-121.
- Gras, R., Peter, P., Briand, H., & Philippé, J. (1997). Implicative Statistical Analysis. In C. Hayashi, N. Ohsumi, N. Yajima, Y. Tanaka, H. Bock, Y. Baba (Eds.), *Proceedings of the 5th Conference of the International Federation of Classification Societies* (Vol. 2, pp. 412-419). Tokyo, Berlin, Heidelberg, New York: Springer-Verlag.
- Greeno, J. G., & Hall, R.P. (1997). Practicing representation: Learning with and about representational forms, *Phi Delta Kappan*, 78, 361-367.
- Hitt, F. (1998). Difficulties in the articulation of different representations linked to the concept of function. *The Journal of Mathematical Behavior*, 17(1), 123-134.
- Markovits, Z., Eylon, B., & Bruckheimer, M. (1986). Functions today and yesterday. *For the Learning of Mathematics*, 6(2), 18-28.

- Mousoulides, N., & Gagatsis, A. (2004). Algebraic and geometric approach in function problem solving. In M. Johnsen Hoines & A. Berit Fuglestad (Eds.), *Proceedings of the 28th Conference of the International Group for the Psychology of Mathematics Education* (Vol. 3, pp. 385-392). Bergen, Norway: Bergen University College.
- Sfard, A. (1992). Operational origins of mathematical objects and the quandary of reification - The case of function. In E. Dubinsky & G. Harel (Eds.), *The concept of function: Aspects of epistemology and pedagogy* (pp. 59-84). United States: The Mathematical Association of America.



The phenomenon of change of the meaning of mathematical objects due to the passage between their different representations: How other disciplines can be useful to the analysis

Bruno D'Amore & Martha Isabel Fandiño Pinilla

NRD – Department of Mathematics – University of Bologna – Italy
Alta Scuola Pedagogica (ASP), Locarno, Switzerland

Abstract

In this paper we will demonstrate a consequence at times manifest in the semiotic transformations involving the treatment and conversion of a semiotic representation whose sense derives from a shared practice. The shift from one representation of a mathematical object to another via transformations maintains the meaning of the object itself on the one hand, but on the other hand it can change its sense. This is demonstrated in detail through a specific example, while at the same time it is collocated within a broad theoretical framework that poses fundamental questions concerning mathematical objects, their meanings and their representations.

Episodes

In D'Amore (2006), D'Amore and Fandiño Pinilla (2007a, b), we have reported and discussed, exclusively from a semiotic structural point of view, episodes taken from classroom situations in which students are mathematics teachers in their initial training, engaged in facing representations problems. Some examples of the phenomenon have been given orally in Rhodes, on April 13th 2006, during a general conference (How the treatment or conversion changes the sense of mathematical objects) at the 5th MEDCONF2007 (Mediterranean Conference on Mathematics Education), 13-15 April 2007, Rhodes, Greece (D'Amore, 2007).

The task consisted in this: working in small groups the trainee teachers received a text written in natural language; such texts had to be transformed into algebraic language. Once they had come to the algebraic formulation, this was explained by the group and collectively discussed. Our duty as university teachers was to suggest the further transformation of the obtained algebraic expressions into other algebraic *expressions*, to face collective discussions on their meaning.

We present three examples below:

Example 1

[We omit the original linguistic formulation which, in this case, is not relevant];

The final algebraic formulation proposed by group 1 is: $x^2+y^2+2xy-1=0$, which in natural language is interpreted as follows: «A circumference» [the interpretation error is evident, but we decide to pass over]; we carry out the transformation which leads to:

$x+y=\frac{1}{x+y}$ that after a few attempts is interpreted as «A sum that has the same value of its reciprocal»;

question: «But $x+y=\frac{1}{x+y}$ is it or not the “circumference” we started with?»;

student A: «Absolutely no, a circumference must have x^2+y^2 »;

student B: «If we simplify, yes».

One can ask whether or not it is the transformation that gives a *sense*: from the episode it seems that if one would perform the inverse passages, then one would return to a “circumference”. But it could also instead be that the meanings are attributed to the specific representations, without links between them, as if the transformation that makes sense for the teacher it does not make sense for the person who performs it.

Example 2

The text written in natural language requires the algebraic writing of the sum of three consecutive natural numbers and the proposal of group II is: $(n-1)+n+(n+1)$ [obviously the doubt remains in the case of $n=0$, but we decide to pass over]; we carry out the transformation that leads to the following writing: $3n$ that is interpreted as: «The triple of a natural number»;

question: «But $3n$ can be thought as the sum of three consecutive natural numbers?»;

student C: «No, *like this* no, *like this* it is the sum of three equal numbers, that is n ».

Example 3

We consider the sum of the first 100 natural positive numbers: $1+2+\dots+99+100$; we perform Gauss classical transformation; 101×50 ; this representation is recognized as the solution of the problem but not as the representation of the starting object; the presence of the multiplication sign compels all the students to look for a sense in mathematical objects in which the “multiplication” term (or similar terms) appears;

question: «But 101×50 is it or not the sum of the first 100 positive natural numbers?»;

student D: «That one, is not a sum, that is a multiplication; it corresponds to the sum, but it is not the sum».

In these episodes we witness a constant change of meaning during the transformations: each new representation has a specific meaning of its own not referable to the one of the starting representations, even if the passage from the first to the second ones has been performed in an evident and shared manner.

The causes of the changes of meaning

What are the causes of the changes of meaning, what origin do they have?

We can start from this diagram that we appreciate a lot because of its attempt to put in the right place the ideas of *sense* and *understanding* (Radford, 2004a).

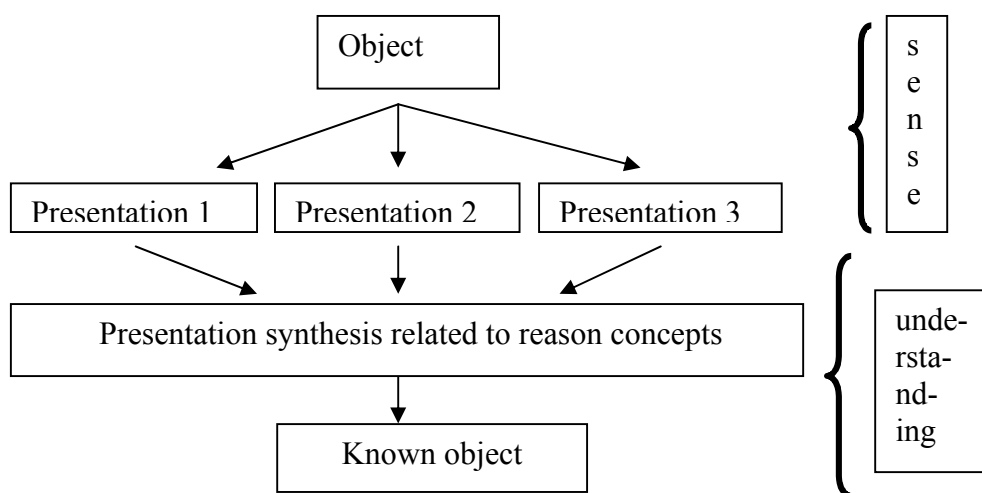

The process of meanings endowment moves at the same time within various semiotic systems, simultaneously activated; we are not dealing with a pure classical dichotomy: treatment/conversion leaves the meaning prisoner of the internal semiotic structure, but with something much more complex. Ideally, from a structural point of view, the meaning should come from within the semiotic system we are immersed in. Therefore, in *Example 2*, the pure passage from $(n-1)+n+(n+1)$ to $3n$ should enter the category: treatment semiotic transformation. But what happens in the classroom practice, and not only with novices in algebra, is different. There is a whole path to cover, starting from single specific meanings culturally endowed to the signs of the algebraic language ($3n$ is the triple of something; 101×50 is a product, not a sum). Thus, there are sources of meanings relative to the algebraic language that anchor to meanings culturally constructed, previously in time; such meanings often have to do with the arithmetic language. From an, so to speak, “external” point of view, we can trace back to seeing the different algebraic writings as equally significant since they are obtainable through semiotic treatment, but from inside this picture is almost impossible, bound as it is to the culture constructed by the individual in time. In other words, we can say that students (not only novices) turn out bridled to sources of meaning that cannot be simply governed by the syntax of the algebraic language. Each passage gives rise to forms or symbols to which a specific meaning is recognised because of the cultural processes THROUGH which it has been introduced.

In Luis Radford's semiotic anthropological approach (ASA) mathematical knowledge is seen as the product of a reflexive cognitive mediated praxis. «Knowledge as cognitive praxis (*praxis cogitans*) underlines the fact that what we know and the way we come to know it are underpinned by ontological positions and by cultural processes of meaning production that give form to a certain way of rationality within which certain types of questions and problems are posed. The *reflexive* nature of knowledge must be understood in Ilyenkov's sense, that is, as a distinctive component that makes cognition an intellectual reflexion of the external world in accordance with the forms of individuals' activity (Ilyenkov, 1977, page 252). The mediated nature of knowledge refers to the role played by tools and signs as means of knowledge objectification and as instruments that allow to bring to a conclusion the cognitive *praxis*» (Radford, 2004b, page 17).

On the other hand, «the object of knowledge is not filtered only by our senses, as it appears in Kant, but overall by the cultural modes of signification (...). (...) the object of knowledge is filtered by the technology of the semiotic activity. (...) knowledge is culturally mediated» (Radford, 2004b, page 20). «(...) These terms are the semiotic means of objectification. Thanks to these means, the general object that always remains directly inaccessible starts to take form: it starts to become an "object of consciousness" for the pupils. Although general, these objects however remain *contextual*» (Radford, 2004b, page 23).

The approach to the object and its appropriation on the part of the individual who learns, are the result of personal intentions with which individuals express themselves through experiences that see the objects used in suitable contexts: «Intentions occur in contextual experiences that Husserl called *noesis*. The conceptual content of such experiences he termed *noema*. Thus, noema corresponds to the way objects are grasped and become known by the individuals while noesis relates to the modes of cultural categorical experiences accounting for the way objects become attended and disclosed (Husserl, 1931)» (Radford, 2002, page. 82).

In the cases we presented above, and in mathematics in general, it is clear that the objects are attended from the first moment in their formal expression, in our case in the algebraic language; the individual learns to formally handle these signs, but what happens to the initial mathematical object? What happens to the initial meanings? We suppose that these meanings are tightly bound to the arithmetic experience of the pupil and overall to the way in which such an experience becomes objective through its objective transposition into ordinary language. Deep understanding of algebraic or, in general, formal manipulation, holds a prominent position.

Through an interesting comparison, Radford expresses himself on this point as follows: «While Russell (1976, page 218) considered the formal manipulations of signs as empty descriptions of reality, Husserl stressed the fact that such a manipulation of signs requires a shift of intention, a noematic change: the focus becomes the signs themselves,

but not as signs *per se*. And he insisted that the abstract manipulation of signs is supported by new meanings arising from rules resembling the rules of a game (Husserl 1961, page 79), which led him talk about signs having a *game signification (...)*» (Radford, 2002, page 88).

After having shown the broad and complex significance of the phenomenon, we must refer to other disciplines in order to understand better and better the issue of the different meanings of algebraic expressions, that is, in order to give a significant contribution to this aspect of mathematics education.

Analysis of the phenomenon thanks to theories “external” of mathematics education

We believe that some theories “external” of mathematics education can have, and in fact they already have, a strong influence on the analyses of various phenomena, like the ones described here, therefore giving a contribution to changing the theoretical frame of our discipline in its future research developments.

Philosophy. In section 2, we have seen how philosophy (Husserl’s phenomenology) can have remarkable contribution and we will not repeat ourselves.

Learning is taking consciousness of a general object in accordance with the modes of rationality of the culture one belongs to.

More importantly we must face here the issue of the philosophical dilemma on concept and object, and even more the problem of the need of a previous choice between realist and pragmatist positions (D’Amore, Fandiño Pinilla, 2001; D’Amore, 2003; D’Amore, 2007).

In **realist theories** the meaning is a «conventional relationship between signs and ideal or concrete entities that exist independently of linguistic signs; they therefore suppose a conceptual realism» (Godino and Batanero, 1994). As Kutschera (1979) already claimed: «According to this conception the meaning of a linguistic expression does not depend on its use in concrete situations, but it happens that the use holds on meaning, since a clear distinction between pragmatics and semantics is possible».

In the realist semantic that it derives, we attribute to linguistic expressions purely semantic functions; the meaning of a proper name (as: ‘Bertrand Russell’) is the object that such proper name indicates (in such a case: Bertrand Russell); the individual statements (as: ‘A is a river’) express facts that describe reality (in such a case; A is the name of a river); the binary predicates (as: ‘A reads B’) designate attributes, those indicated by the phrase that expresses them (in this case: person A reads thing B). Therefore every linguistic expression is an attribute of certain entities: the nominal relationship that derives is the only semantic function of expressions.

We recognise here the bases of Frege's, Carnap's and Wittgenstein's (*Tractatus*) positions.

A consequence of this position is the acknowledgement of a "scientific" observation (at the same time therefore, empiric and subjective or intersubjective) as it could be, at a first level, a statement and predicate logic.

From the point of view we are mostly interested in, if we apply to Mathematics the ontological assumption of realist semantics, we necessarily draw a platonic picture of mathematical objects: notions, structures, etc. have a real existence that does not depend on human being, as they belong to an ideal domain; "to know" from a mathematical point of view means "to discover" in such domain entities and relationships between them. It is also obvious that such picture implies an absolutism of mathematical knowledge, since it is thought as a system of external certain truths that cannot be modified by human experience because they precede or, at least, are extraneous and independent from it.

Akin positions, although with different nuances, were sustained by Frege, Russell, Cantor, Bernays, Goedel,...; they also encountered violent criticisms [Wittgensteins' *Conventionalism* and Lakatos' *quasi-empirism* : see Ernest (1991) and Speranza (1997)].

In **pragmatic theories** linguistic expressions have different meanings according to the context in which they are used and therefore any scientific observation is impossible, since the only possible analysis is a "personal" and subjective one, anyway circumstantial and not generalizable. We cannot but analyse the different "uses": the set of "uses" in fact determines the meaning of objects.

We recognize here Wittgenstein's positions of the *Philosophical Investigations*, when he admits that the significance of a word depends on its function in a "linguistic game", since in such game it has a way of 'use' and a concrete purpose for which it has been precisely used: therefore the word does not have a meaning *per se*, but nevertheless, it can be meaningful.

Mathematical objects are therefore symbols of cultural units that emerge from a system of uses that characterise human pragmatics (or at least of individuals' homogeneous groups) and that continuously modify in time, also according to needs. In fact, mathematical objects and the meaning of such objects depend on the problems that we face in Mathematics and on their solution processes.

	“REALIST” THEORIES	“PRAGMATIC” THEORIES
meaning	conventional relationship between signs and concrete or ideal entities independent of linguistic signs	depends on the context and use
semantics Vs pragmatics	clear distinction	no distinction or faded distinction
objectivity or intersubjectivity	complete	missing or questionable
semantics	linguistic expressions have purely semantic functions	linguistic expressions and words have “personal” meanings, are meaningful in suitable contexts, but they don’t have absolute meanings <i>per se</i>
analysis	possible and licit: logic for example	only a “personal” or subjective analysis is possible, not generalizable, not absolute
consequent epistemological picture	platonic conception of mathematical objects	problematic conception of mathematical objects
to know	to discover	to use in suitable contexts.
knowledge	is an absolute	is relative to circumstance and specific use
examples	Wittgenstein in <i>Tractatus</i> , Frege, Carnap [Russell, Cantor, Bernays, Gödel]	Wittgenstein in <i>Philosophical Investigations</i> [Lakatos]

It is obvious and it would be easy to prove with philosophical examples, that the two fields are not fully complementary and clearly separated even if, for reasons of clarity, we preferred giving this “strong” impression.

With regard to the philosophical bases of mathematics education, we have decided to stay in the pragmatic domain that seems much closer to the reality of the empiric process of Mathematics teaching/learning. It seems that each specification that appears in the right column, cell by cell, is part of the same process and of its explicitation. It seems that focusing didactic activity (and therefore research) on learning and consequently on epistemology of the domain that has the student as a protagonist, we are obliged to interpret each step of knowledge construction as responding to the *language game*, therefore admitting that the semantics blur the use pragmatics.

Sociology. In D’Amore (2005) and D’Amore and Godino (2007), we show how the results of the analyses relative to the behaviours of individuals engaged in an activity of conceptual learning of mathematical objects, their transformations of the descriptions of such objects from ordinary language to formal language, the manipulations of such formalizations can be framed within a sociological interpretation key: the learning environment is framed within a sociological interpretation key and the individuals’ behaviours are interpreted through the notion of “practice” and its “meta-practice” evolution. Essentially the individuals shift from a shared practice, recognized as characteristic of the social group they belong to, to a meta-practice that modifies such characteristic; the interpretative behaviour therefore ceases to be global and social and

becomes local and personal; the notions that come into play in such interpretations are specific of the circumstance and not of the situation in its entirety.

We pass over this point, referring back to the quoted texts.

Anthropology. In D'Amore and Godino (2006, 2007) we go into strongly anthropological details in order to explain the nature of the choices of the individual who learns mathematics. In such articles we highlight how «Having obliged the researcher to point all his attention to the activities of human beings who have to do with mathematics (not only solving problems, but also communicating mathematics) is one of the merits of the anthropological point of view, inspiring other points of view, amongst which the one that today we call “anthropological” in the proper sense: the ATD, anthropological theory of didactics (of mathematics) (Chevallard, 1999; page 221). Why this adjective “anthropological”? It is not an exclusiveness of the approach created by Chevallard in 80s, as he himself declares (Chevallard, 1999), but an “effect of the language” (page 222); it distinguishes the theory, identifies it, but it is not peculiar to such theory in a univocal way» (D'Amore and Godino, 2006, page 15). The ATD is almost exclusively centred on the institutional dimension of mathematical knowledge, as a development of the research program started with fundamental didactics. The crucial point is that «ATD places the *mathematical* activity, and therefore *the study* in mathematics activity, *in the set of human activities and of social institutions*» (Chevallard, 1999).

This kind of analyses, although subjected to criticisms in D'Amore and Godino (2006, 2007), has opened the way to the use of anthropology as a critical instrument, as a new theoretical frame at research into mathematics education, in accordance with what has been already highlighted in the above quoted articles. It is the human being, strong of the acquired culture, strong of the specific expressive, communicative luggage, who handles formal writings and gives them a meaning that it cannot be anything else but coherent with his social history; every meaning of each formal expression is the result of an anthropological comparison between a lived history and a here-and-now that must be coherent with that history.

We pass over this point, referring back to the quoted texts.

Psychology. In D'Amore and Godino (2006) we show how the shift from the anthropological picture to the onto-semiotic one is made necessary (amongst other things) by the need of not trivializing the presence of psychology in the study of learning and, in general, classroom situations. In D'Amore (1999) we show, for example, how ideas on representation drawn from psychology, regarding the explanation of the passage from image (weak) to model (stable) of concepts (Paivio, 1971; Kosslyn, 1980; Johnson-Laird, 1983; Vecchio, 1992), can be placed as a unitary basis of the explanation of several didactic phenomena, as intuitive models, the shift from internal to external models, the figural concepts, up to misconceptions, studied mainly in the 80s. Also the ideas of frame and script (Bateson, 1972; Schank and Abelson, 1977) have been used for the same purpose.

References

- Bateson G. (1972). *Steps to an Ecology of Mind*. Novato Ca.: Chandler Publishing Company.
- Chevallard Y. (1999). L'analyse des pratiques enseignantes en théorie anthropologique du didactique. *Recherches en Didactique des Mathématiques* (Grénoble, France). 19, 2, 221-266.
- D'Amore B. (2003). *Le basi filosofiche, pedagogiche, epistemologiche e concettuali della didattica della matematica*. Bologna: Pitagora. Portuguese edition (Sao Pãolo: Escrituras, 2005) and Spanish edition (Barcelona-México: Reverté, 2005).
- D'Amore B. (2005). Pratiche e metapratiche nell'attività matematica della classe intesa come società. Alcuni elementi rilevanti della didattica della matematica interpretati in chiave sociologica. *La matematica e la sua didattica* (Bologna, Italy). 3, 325-336.
- D'Amore B. (2006). Objetos, significados, representaciones semióticas y sentido. In: L. Radford and B. D'Amore (eds.) (2006). *Semiotics, Culture and Mathematical Thinking*. Special issue of the journal *Relime* (Cinvestav, México DF., México). 177-196.
- D'Amore B. (2007). How the treatment or conversion changes the sense of mathematical objects [Invited speaker article]. In: E.P. Avgerinos and A. Gagatsis (eds.) (2007). *Current trends in Mathematics Education*. Proceedings of 5th MEDCONF 2007 (Mediterranean Conference on Mathematics Education), 13-15 April 2007, Rhodes, Greece. Athens: New Technologies Publications. 77-82. ISBN: 978-960-89713-0-1.
- D'Amore B. and Fandiño Pinilla MI. (2001). Concepts et objets mathématiques. In: Gagatsis A. (ed) (2001). *Learning in Mathematics and Science and Educational Technology*. Atti del Third Intensive Programme Socrates-Erasmus, Nicosia, Università di Cipro, 22 Giugno – 6 luglio 2001. Nicosia (Cjprus): Intercollege. 111-130.
- D'Amore B. and Fandiño Pinilla M.I. (2007a). How the sense of mathematical objects changes when their semiotic representations undergo treatment and conversion. *La matematica e la sua didattica* (Bologna, Italy). Vol. 21, n. 1, 87-92. Proceedings of : Joint Meeting of UMI-SIMAI/SMAI-SMF: *Mathematics and its Applications*. Panel on Didactics of Mathematics. Department of Mathematics, University of Turin. July 6, 2006.
- D'Amore B. and Fandiño Pinilla M.I. (2007b). Change of the meaning of mathematical objects due to the passage between their different representations. How other disciplines can be useful to the analysis of this phenomenon. Rome, *Symposium on the occasion of the 100th anniversary of ICMI*, March 2008. WG5: *The evolution of theoretical framework in mathematics education*, organizers: Gilah Leder and Luis Radford. www.unige.ch/math/EnsMath/Rome2008

- D'Amore B. and Godino D.J. (2006). Punti di vista antropologico ed ontosemiotico in Didattica della Matematica. *La matematica e la sua didattica* (Bologna, Italy). 1, 9-38.
- D'Amore B. and Godino D.J. (2007). El enfoque ontosemiótico como un desarrollo de la teoría antropológico en didáctica de la matemática. *Relime* (Cinvestav, México DF., México). Accepted, forthcoming.
- Ernest P. (1991). *The philosophy of mathematics education*. London: Falmer Press.
- Husserl E. (1931). *Ideas*. London (U. K.): The Macmillan Company.
- Husserl E. (1961). *Recherches logiques*. (Recherches I et II). Paris (France): PUF.
- Godino J., Batanero C. (1994). Significado institucional y personal de los objetos matemáticos. *Recherches en Didactique des Mathématiques*. 14, 3, 325-355.
- Ilyenkov E.V. (1977). *Dialectical Logic*. Moscow (URSS): Progress Publishers.
- Johnson-Laird P.N. (1983). *Mental Models*. Cambridge Ma.: Cambridge Univ. Press.
- Kosslyn S.M. (1980). *Image and Mind*. Cambridge Ma.: Harvard Univ. Press.
- Kutschera F. von (1979). *Filosofía del lenguaje*. Madrid: Gredos.
- Paivio A. (1971). *Imagery and Verbal Processes*. New York: Holt, Rinehart and Winston.
- Radford L. (2002). On heroes and the collapse of narratives: a contribution on the study of symbolic thinking. In: A.D. Cockburn and E. Nardi (eds.) (2002). *Proceedings of the 16th Conference of the International Group for the Psychology of Mathematics Education, PME 26*. Vol. 4, 81-88.
- Radford L. (2003). Gestures, speech and the sprouting of signs. *Mathematics Thinking and Learning* (Florence, Kentucky, USA). 5(1), 37-70.
- Radford L. (2004a). Cose sensibili, essenze, oggetti matematici ed altre ambiguità. *La matematica e la sua didattica* (Bologna, Italy). 1, 4-23.
- Radford L. (2004b). La généralisation mathématique comme processus sémiotique. In: G. Arrigo (ed.) (2004). *Proceedings of the Ticino Mathematics Education Conference*. Quaderni Alta Scuola Pedagogica. Bellinzona (Switzerland): Centro didattico cantonale. 11-27.
- Russell B. (1976). *An Inquiry into Meaning and Truth*. London (U.K.): G. Allen and Unwin.
- Schank R.C., Abelson R.P. (1977). *Scripts plans goals and understanding*. Hillsdale N.J.: Lea.
- Speranza F. (1997). *Scritti di Epistemologia della Matematica*. Bologna: Pitagora.
- Vecchio L. (1992). Breve storia delle ricerche sull'immagine mentale. In: L. Vecchio (ed.) (1992). *Le immagini mentali*. Proceedings of the homonymous Meeting of Pavia (October, 1990). Firenze, Italy: La Nuova Italia. 15-48.



The structure of fraction addition understanding: A comparison between the hierarchical clustering of variables, implicative statistical analysis and confirmatory factor analysis¹

Eleni Deliyianni *, Iliada Elia *, Athanasios Gagatsis * & Areti Panaoura**

*University of Cyprus, **Frederick University

Abstract

The aim of the study was to combine and compare the outcomes of confirmatory factor analysis (CFA), hierarchical clustering of variables and implicative method concerning 5th and 6th graders fraction addition understanding. CFA affirmed the existence of seven first-order factors indicating the differential effect of task modes of representation, representation functions and required cognitive processes, two second-order factors representing multiple representation flexibility and problem solving ability and a third-order factor that corresponded to the fraction addition understanding. Using hierarchical and implicative analysis, evidence was provided of students' attempt to overcome compartmentalized thinking. However, primary students did not construct the whole meaning of the concept of fraction addition yet. The outcomes of the three methods were found to coincide and complement.

Introduction

There is a basic difference between mathematics and other domains of scientific knowledge as the only way to access mathematical objects and deal with them is by using signs and semiotic representations. Given that a representation cannot describe fully a mathematical construct and that each representation has different advantages, using multiple representations for the same mathematical situation is at the core of mathematical understanding (Duval, 2006).

Nowadays the centrality of different types of external representations in teaching and learning mathematics seems to become widely acknowledged by the mathematics education community (e.g. Elia & Gagatsis, 2006). Furthermore, the NCTM's Principles and Standards for School Mathematics (2000) document includes a new process standard that addresses representations and stresses the importance of the use of multiple representations in mathematical learning. Duval (2006) maintains that

¹ This report constitutes a part of the medium research project MED19, funded by the University of Cyprus.

mathematical activity can be analyzed based on two types of transformations of semiotic representations, i.e. treatments and conversions. Treatments are transformations of representations, which take place within the same register that they have been formed. Conversions are transformations of representations that involve the change of the register in which the totality or a part of the meaning of the initial representation is conserved, without changing the objects being denoted. In fact, recognizing the same concept in multiple systems of representations, the ability to manipulate the concept within these representations as well as the ability to convert flexibly the concept from one system of representation to another are necessary for the acquisition of the concept (Lesh, Post, & Behr, 1987) and allow students to see rich relationships (Even, 1998). Moving a step forward, Hitt (1998) identified different levels in the construction of a concept, which are strongly linked with its semiotic representations. The particular levels are as follow: 1) incoherent mixture of different representations of the concept, 2) identification of different representations of a concept, 3) conversion with preservation of meaning from one system of representation to another, 4) coherent articulation between two systems of representations, 5) coherent articulation between two systems of representations in the solution of a problem.

Lack of competence in coordinating multiple representations of the same concept can be seen as an indication of the existence of compartmentalization, which may result in inconsistencies and delays in mathematics learning at school. The particular phenomenon reveals a cognitive difficulty that arises from the need to accomplish flexible and competent translation back and forth between different modes of mathematical representations (Duval, 2002).

Aim and research predictions

The aim of the study was to combine and compare the outcomes of confirmatory factor analysis (CFA), hierarchical clustering of variables and implicative method on the same sample data concerning student multiple representation flexibility and problem solving ability as far as fraction addition understanding was concerned. In fact, a main concern was to gain insight into the distinct features, advantages and limitations of each of the three statistical methods in a significant topic of mathematics education, namely the understanding of the concept of fraction addition, and to examine whether they coincided or even complemented each other.

Method

The study was conducted among 829 pupils aged 10 to 12 of different primary schools in Cyprus (414 5th graders, 415 6th graders). The test that was constructed in order to examine the hypothesis of this study included:

1. Recognition tasks in which the pupils were asked to identify similar (RELa, RECa, RERa, RELb, RERb) and dissimilar (RELc, RERc, RECc) fraction addition in number line, rectangular and circular area diagrams.
2. Conversion tasks having the diagrammatic and the symbolic representation as the initial and the target representation, respectively. Similar fraction additions were presented in number line (COLSs) and circular area diagram (COCSSs), whereas

- dissimilar fraction additions were presented in number line (COLSd) and rectangular area diagram (CORSd).
3. Symbolic treatment tasks of similar (TRSa) and dissimilar (TR Sb, TRSc) fraction addition.
 4. Conversion tasks having the symbolic and the diagrammatic representation as the initial and the target representation, respectively. Pupils were asked to present the similar fraction addition in circular area diagram (COSC) and in number line (COSL), whereas they were asked to present the dissimilar fraction additions in rectangular area diagram (COSRd).
 5. Diagrammatic addition problem in which the unknown quantity was the summands (PD).
 6. Verbal problem that was accompanied by auxiliary diagrammatic representation and the unknown quantity is the summands (PVD).
 7. Verbal problem whose solution required not only fraction addition but also the knowledge of the ratio meaning of fraction (PV).
 8. Justification task that was presented verbally and was related to similar or dissimilar fraction addition (JV).

Representative samples of the tasks used in the test appear in the Appendix. It should be noted, that not any diagrammatic representation treatment tasks are included in the test since the students' ability to manipulate diagrammatic representations was examined through conversion tasks in which the target representation is a diagram.

Results

Confirmatory factor analysis outcomes

CFA was used to test statistically whether a hypothesized connection pattern between the observed variables and the underlying factors exist. Our first prediction dealt with the structure of the processes underlying fraction addition understanding. Specifically, keeping in mind the classic difference between "exercise" and "problem" (Polya, 1945; Dunker, 1945; D' Amore & Zan, 1996), we expected that fraction addition multiple representation flexibility and problem solving ability would differentially affect the fraction addition understanding, since they activate different mental processes.

We also assumed that fraction addition multiple representations flexibility would constitute a multifaceted construct in which other variables in addition to functions (recognition, treatment, conversion, according to Lesh et al., 1987) the representations fulfilled would be involved. These variables would be the modes of representations and relative concepts of similar and dissimilar fraction addition. To be specific, primarily we expected that the ability to recognize fraction addition in various diagrammatic representations, the ability to manipulate symbolic fraction addition equations and to convert from one fraction addition representation to another would come out as distinct dimensions of performance. We also assumed that the concept of similar and dissimilar fraction addition would affect the ability to recognize fraction addition in multiple diagrammatic representations. In fact we pointed out that a student who recognizes a similar fraction addition in a diagrammatic representation should bear in mind that the

summands are represented on the same diagram which has the same number of subdivisions (or a multiple) as the denominator. On the other hand, when a student recognizes dissimilar fraction addition in a diagrammatic representation he/she should bear in mind that each summand were represented on a different diagram. Each of these diagrams has the same number of subdivisions as the denominator of the corresponding fraction. Then, the student identifies a diagram in which the number of subdivisions is the least common multiple of the two denominators. Taking this process into account the high association of the fraction equivalence with dissimilar fraction addition understanding was indicated, as well. Thus, in CFA the ability to recognize similar and dissimilar fraction addition would come out as distinct dimensions of performance. On the other hand, we assumed that the ability to solve symbolic similar and dissimilar fraction addition would be one factor since students were familiar with both of them. In fact, symbolic similar and dissimilar fraction addition treatments based heavily on basic algorithms and the specific processes automated by the age group students involved here.

Furthermore, we expected that the different types of representation would differentially affect the solution process, because they activated different mental processes when processing the tasks. Demetriou, Efklides and Platsidou (1993) showed that the nature of representation and symbol system used to express information is an independent dimension organizing cognitive performance in addition to the mental operations and types of relations involved. Therefore, in confirmatory factor analysis, the ability to convert flexibly from diagrammatic to symbolic equation would come out as a dimension of performance distinct from the ability to convert flexibly from a fraction addition equation to a diagrammatic representation. Furthermore, we expected that the presence of a diagrammatic representation would differentially influence fraction addition problem solving.

In order to explore the structure of the various fraction addition understanding dimensions a third-order CFA model for the total sample was designed and verified. Bentler's (1995) EQS programme was used for the analysis. The tenability of a model can be determined by using the following measures of goodness-of-fit: χ^2 , CFI (Comparative Fit Index) and RMSEA (Root Mean Square Error of Approximation). The following values of the three indices are needed to hold true for supporting an adequate fit of the model: $\chi^2/df < 2$, $CFI > .9$, $RMSEA < .06$. The a priori model hypothesized that the variables of all the measurements would be explained by a specific number of factors and each item would have a nonzero loading on the factor it was supposed to measure. The model was tested under the constraint that the error variances of some pair of scores associated with the same factor would have to be equal.

Figure 1 presents the results of the elaborated model, which fits the data reasonably well ($\chi^2/df=1.911$, $CFI=0.968$, $RMSEA=0.033$). In fact, the third-order model which was considered appropriate for interpreting fraction addition understanding, involved seven first-order factors. The first-order factors F1 to F5 regressed on a second-order factor that stood for the multiple representations flexibility. The first-order factor F1 referred

to the similar fraction addition recognition tasks, while the first-order factor F2 to the dissimilar fraction addition recognition tasks in a variety of diagrammatic representations. The first-order factor F3 consisted of the similar and dissimilar fraction addition treatment tasks. Conversion tasks in which the initial and the target representation was similar and dissimilar fraction equation and diagrammatic representation, respectively, constituted the first-order factor F4, while the first-order factor F5 referred to the similar and dissimilar fraction addition conversion tasks from a diagrammatic to a symbolic representation.

The factor loadings indicated that conversion from a diagrammatic to a symbolic representation was more closely associated with multiple representations flexibility than the other first-order factors were. Nevertheless, the first-order factor F1 to F4 loadings strength revealed that the flexibility in multiple representations of similar and dissimilar fraction addition constituted a multifaceted construct in which relations between: a) modes of representation (symbolic, diagrammatic), b) functions (recognition, treatment, conversion) fulfilled by representations and c) relative concepts (similar and dissimilar fractions, equivalence) arose.

The majority of tasks which involved number line had higher loadings than the other tasks, suggesting that the number line model was more strongly related to multiple representations flexibility than the circular and rectangular diagrams. Furthermore, dissimilar fraction tasks loadings were higher than the respective similar fraction addition loadings, indicating that in order to be solved different mental processes were required since the fraction equivalence understanding was involved, as well. The specific knowledge was also needed to solve similar fraction addition recognition tasks in which the number of subdivision was double that of the denominator (e.g. RERa). As a result, higher loadings were observed in these tasks relative to other similar fraction addition tasks.

The other two first-order factor F6 and F5 regressed on a second-order factor that represents problem solving ability. The first-order factor F6 consisted of problems having a diagram as an autonomous or an auxiliary representation. Both of them had a common mathematical structure since they had the summands as the unknown quantity. On the other hand, the verbal problem whose solution required the knowledge of the ratio meaning of fraction and the justification task formed the first-order factor F7, since in order to be solved different cognitive processes were needed. The two second-order factors that correspond to the multiple representations flexibility and to the problem solving ability regressed on a third-order factor that stood for the fraction addition concept understanding. Their loadings values were almost the same revealing that pupils' fraction addition understanding is predicted from both multiple representations flexibility and problem solving ability.

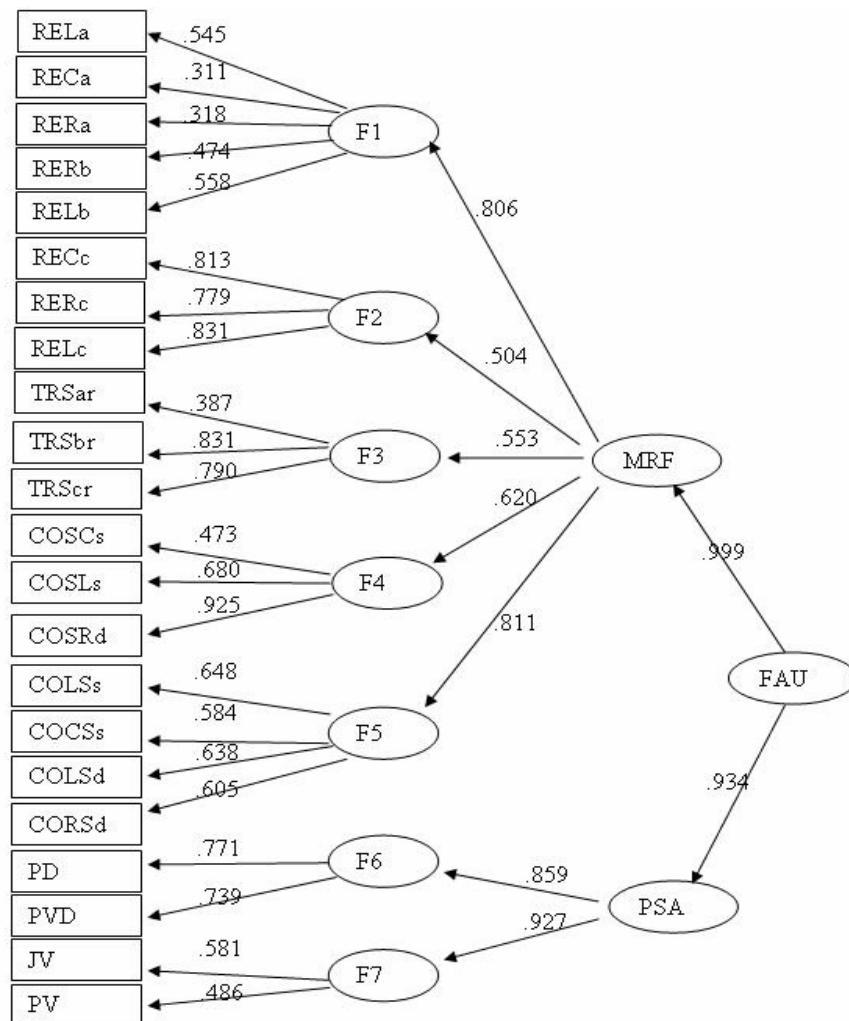

Figure 1: The CFA model of the fraction addition understanding

Note: 1. Errors of the variables were omitted. 2. MRF= multiple representation flexibility, PSA= problem solving ability, FAU= fraction addition understanding

The outcomes of the hierarchical clustering of variables and the implicative method of analysis

The hierarchical clustering of variables aimed at bringing to light the consistency among student responses to the various tasks in a hierarchical manner. The implicative method gave information about whether success on one task implied success at another task and about the relative difficulty of the tasks based on student performance. In fact, we expected that similarity and implicative relationships would be primarily established among the variables corresponding to the functions the representation fulfilled, namely recognition, treatment and conversion, and secondly among the variables corresponding to the conversions of the same starting representation, namely symbolic and diagrammatic representation. This hypothesis was based on findings suggesting the

fragmentary way of student thinking when dealing with different types of representation (Duval, 2006; Gagatsis, Elia, & Mougi, 2002) and the lack of flexibility between different ways of approaching concepts (Elia, Panaoura, Eracleous, & Gagatsis, 2006). A second prediction was that distinctly close relationships will be formed among variables standing for similar or dissimilar fraction addition recognition tasks. Third, we assumed that success on similar fraction addition tasks would entail success on dissimilar fraction addition tasks. In fact, we considered the understanding of similar fraction addition and fraction equivalence, as well, as the prerequisite for the understanding of dissimilar fraction addition concept.

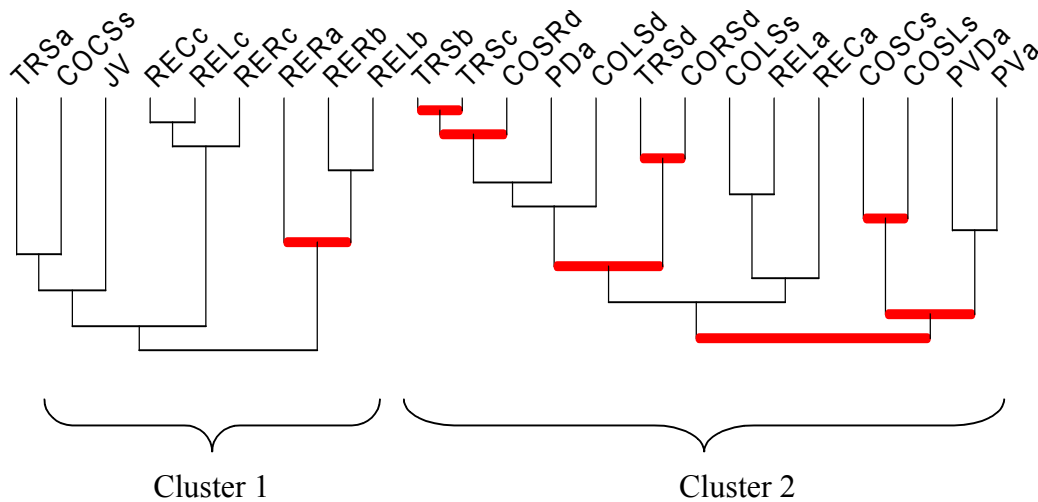

Figure 2: The hierarchical similarity diagram among the responses of primary school students to fraction addition tasks

Figure 2 illustrates the similarity relations among the variables corresponding to grade 5 and 6 student responses to the tasks of the test. Two distinct clusters of variables were established in the hierarchical similarity diagram. The first cluster involved three similarity groups. The first group included a symbolic similar fraction addition treatment task, the conversion having circular area diagram and a similar fraction addition equation as the source and the target representation, respectively, and the justification fraction addition problem (TRSa, COCSs, JV). The second group involved the dissimilar fraction addition recognition tasks in various diagrammatic representations (RECc, RELc, RERc), while similar fraction addition recognition tasks in which the number of subdivision was double that of the denominator (RERa, RERb, RELb) formed the third similarity group. The connection between treatment and conversion from diagrammatic to symbolic representation fraction addition tasks implied that students carried out these tasks in a similar way since even though these tasks fulfilled different functions they referred to the similar fraction addition concept. Similar fraction addition concept influence also arose in justification problem solving. Furthermore, the second and third group formation indicated that in order to solve similar and dissimilar fraction addition recognition tasks different cognitive processes were required. However, their similarity connection provided further support for the

assertion that equivalent concept knowledge was needed so as to develop similar and dissimilar fraction addition recognition ability.

The second cluster involved three similarity groups, as well. The first group mainly included dissimilar fraction addition treatment and conversion tasks as well as the diagrammatic fraction addition problem (TRSB, TRSc, COSRd, PDa, COLSd, TRSd, CORSD). Thus, the formation of the first group underlined the differential role similar and dissimilar fraction addition exerted on multiple representation flexibility. The similarity connection among these variables indicated also that the students tackled diagrammatic fraction addition problem solving and dissimilar fraction addition treatment and conversion tasks, using similar processes. The second and the third group included mainly similar fraction addition tasks. Specifically, conversion task having the number line and similar fraction addition equation as the source and the target representations were linked together in the second group (COLSs, RELa, RECa). On the other hand, the third group included two conversion tasks having similar fraction addition equation and diagrammatic representation as the source and the target representations, respectively, the verbal problem with diagrammatic auxiliary representation and the verbal problem task (COSC, COSL, PVDa, PVa). The similarity relationships were established among the two group variables corresponding to similar and dissimilar fraction concept and the initial mode of representation. In fact, conversion tasks having a diagram and an equation as the source representation were involved in the second and the third group, respectively. Even though, similar fraction addition tasks were included in distinct groups, the similarity relationship between them revealed that the students tackled them almost in a “de-compartmentalized” way.

Nevertheless, the phenomenon of compartmentalization still exists since the tasks included in two clusters were differentially approached. In fact, the 5th and 6th graders did not yet understand that even though the various representations fulfilled different functions they referred to the same concept. It is also worth mentioning that the students did not approach problem solving tasks in a different way from multiple representation flexibility tasks. As a result, the interaction of both multiple representations flexibility and problem solving ability as far as fraction addition conceptual understanding was concerned revealed.

Figure 3 shows the implicative relations among the variables corresponding to 5th and 6th graders responses to the tasks of the test.

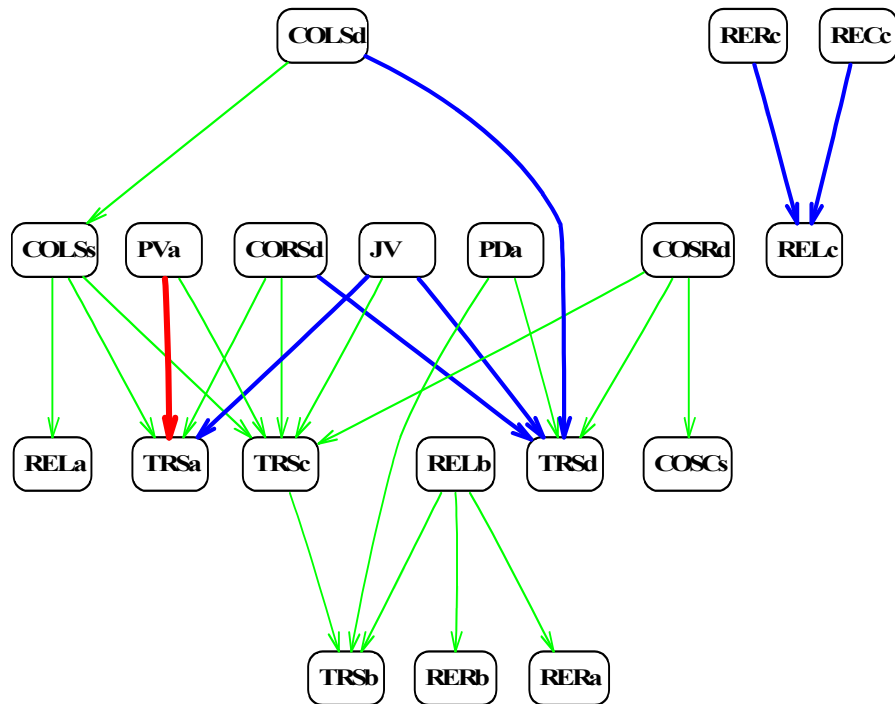

Figure 3: The implicative diagram among the responses of primary school students to the test tasks

The establishment of different implicative chains between similar and dissimilar fraction addition recognition tasks gave further support to the differential role similar and dissimilar fractions exerted on recognition ability. As far as conversion tasks are concerned, carrying out the conversion task having the dissimilar fraction addition equation and rectangular area diagram as the source and the target representation, respectively, implied success in the conversion task having the similar fraction addition equation and circular area diagram as the source and the target representation, respectively. Furthermore, carrying out the conversion task having number line and dissimilar fraction equation, as the source and target representation, respectively, implied success in the conversion task having number line and similar fraction addition equation as the source and the target representation, respectively, which in turn entailed correct performance in the similar fraction addition recognition in a number line task. In fact, the results indicated that implicative relationships primarily formed among variables corresponding to the conversions of the same starting representation. Furthermore, the students' difficulties in carrying out dissimilar fraction addition tasks were underlined. The fact that similar and dissimilar fraction addition treatment tasks were found in the chain endings implied that the specific processes automated by the primary school students were involved here. It should be also mentioned that problem solving tasks entailed success in symbolic similar and dissimilar fraction addition treatment tasks, indicating that 5th and 6th graders depended primarily on symbolic manipulations in order to solve them.

Discussion

This study investigated students' fraction addition understanding as far as multiple representation flexibility and problem solving ability were concerned. The data were analyzed from different perspectives using three distinct statistical methods, each of which was based on a different rationale. A major concern of this study was to compare in detail the findings of the hierarchical clustering of variables, implicative statistical analysis and confirmatory factor analysis so as to learn whether their outcomes on the same sample data were congruent and complement to each other.

The results provided a strong case for the important role of the multiple representations flexibility and problem solving ability in 5th and 6th graders fraction addition understanding. Specifically, CFA showed that two second-order factors were needed to account for the flexibility in multiple representations and the problem solving ability. Both of these second-order factors were highly associated with a third-order factor representing the fraction addition understanding. The outcomes of the other two methods were in line with CFA findings. In fact, the similarity connection between problem solving and multiple representation flexibility tasks and implicative relations between problem and treatment tasks suggested the interaction of both multiple representation flexibility and problem solving ability in fraction addition understanding.

CFA also showed that five first-order factors were required to account for the second-order factor that stood for the flexibility in multiple representations and two first-order factors were needed to explain the second-order factor that represented the problem solving ability. Thus, the results indicated the varying effect of both problem modes of representation and required cognitive processes on problem solving ability. Furthermore, the findings provided evidence to Duval's (2006) view that changing modes of representation is the threshold of mathematical comprehension for learners at each stage of the curriculum since the conversion from a diagrammatic to a symbolic representation dimension was more strongly related to multiple representations flexibility than the other dimensions were. Nevertheless, the factors loadings of the proposed three-order model suggested that the flexibility in multiple representations constituted a multifaceted construct in which representations, functions of representations and relative concepts were involved. In fact, the ability to recognize similar and dissimilar fraction addition in a variety of diagrammatic representations, manipulate similar and dissimilar fraction addition equations and converse flexibly from diagrammatic to symbolic representation standing for similar and dissimilar fraction addition, and vice versa, were necessary for multiple fraction addition representation flexibility. As a result, the separate grouping of the responses to multiple representation flexibility tasks in hierarchical clustering of variables analysis revealed student inconsistencies when dealing with them. In fact, the students tackled in a distinct way relative to the other multiple representation flexibility tasks, the similar and dissimilar fraction addition recognition tasks in which the number of subdivisions was a multiple of the denominator, a similar fraction addition equation and a conversion task having circular area diagram and similar fraction equation as a source and target representation, respectively.

On the other hand, the students carried out similar and dissimilar fraction addition treatment and conversion tasks in an almost consistent way taking into account the underlying concept. Furthermore, similarity connection among conversion tasks with different initial representation indicated 5th and 6th graders' attempt to breach the "compartmentalization" phenomenon. However, implicative relations established primarily among conversion tasks with the same starting representation indicated that students did not construct the whole meaning of the concept of fraction addition yet.

Regarding CFA findings it is worth mentioning that the high factor loadings in tasks involving number line revealed the specific model's importance in fraction addition and the different cognitive processes which were activated in order to handle it relative to other diagrammatic representations. In fact the number line is a geometrical model, which involves a continuous interchange between a geometrical and an arithmetic representation. Operations on real number are represented as operations on segments on the line (e.g. Michaelidou, Gagatsis, & Pitta- Pantazi, 2004). That is, the number line has been acknowledged as a suitable representational tool for assessing the extent to which students have developed the measure interpretation of fractions and for reaching fractions additive operations (e.g. Keijzer & Terwel, 2003).

Furthermore, the strength of factor loadings in dissimilar fraction addition tasks confirmed that different mental processes relatively to the corresponding similar fraction addition were required so as to be solved since the knowledge of fraction equivalence was also needed. The fact that recognition of similar and dissimilar fraction recognition tasks were found to have considerable autonomy between them and the other tasks in implicative chains confirmed the CFA findings. Implicative relations revealed also that dissimilar fraction addition tasks increased difficulty in relation to the corresponding similar fraction addition tasks. In fact, the high association of the fraction equivalence with fraction addition understanding was highlighted by all the three analyses. As Smith (2002) points out in order to develop fully the measure personality of fractions pupils need to master the equivalence of fractions.

On the other hand, the fact that success in similar and dissimilar fraction addition treatment tasks entailed success in problem solving and conversion tasks provided evidence that the treatment processes were automatically carried out by the 5th and 6th graders. This is in line with CFA results that similar and dissimilar fraction did not differentially affect fraction addition symbolic manipulation ability.

In general, the application of all the analyses yielded congruent results. However, at the same time given that these statistical processes approached the data from different perspectives, they emphasized different aspects of student outcomes. This differentiation allowed for the accumulation of a number of new distinctive elements in each analysis that contributed to the unravelling and making sense of student performance, the structure of abilities, difficulties and inconsistencies on the particular subject. The findings of the study suggested that the three statistical methods were open to complementary use and each one did not operate at the expense of the other. CFA provided a means of making sense of the structure of student multiple representation

flexibility and problem solving ability as far as fraction addition understanding was concerned. The hierarchical clustering of variables provided a means of classifying student responses, of identifying student consistencies and inconsistencies among different abilities and for investigating the factors influencing this behaviour. The implicative method provided a means of examining the implicative relations among the responses to the tasks and the relative difficulty of the fraction addition tasks on the basis of student performance. Provided that applying these methods of analysis is consistent with the objectives of a study, their combination on the same sample data could contribute to the overcoming some significant limitations of each analysis employed separately, and consequently could enrich and deepen the outcomes of the investigation.

References

- Bentler, M. P. (1995). *EQS Structural equations program manual*. Encino, CA: Multivariate Software Inc.
- D' Amore, B., & Zan, R. (1996). *Mathematical problem solving*. Retrieved August 22, 2007 from <http://ued.uniandes.edu.co/servidor/em/recinf/libros/italian/problemsolving.html>
- Demetriou, A., Efklides, A., & Platsidou, M. (1993). The architecture and dynamics of developing mind: experiential structuralism as a frame for unifying cognitive developmental theories. In: *Monographs of the Society for Research in Child Development*, Vol. 58 (5-6). (Serial no. 234).
- Duncker, K. (1945). On problem solving. *Psychological Monographs*, 58 (270), 1-112.
- Duval, R. (2006). A cognitive analysis of problems of comprehension in learning of mathematics. *Educational Studies in Mathematics*, 61, 103- 131.
- Elia, I., & Gagatsis, A. (2006). The effects of different modes of representations on mathematical problem solving: Two experimental programs. In J. Novotna, H. Moraova, M. Kratka, & N. Stehlikova (Eds.), *Proceedings of the 30th Conference of the International Group for the Psychology of Mathematics Education* (Vol. 3, pp. 25- 32). Prague, Czech Republic: PME.
- Elia, I., Panaoura, A., Eracleous, A., & Gagatsis, A. (2006). Relations between secondary pupils' conceptions about functions and problem solving in different representations. *International Journal of Science and Mathematics Education*, 5, 533-556.
- Even, R. (1998). Factors involved in linking representations of functions. *The Journal of Mathematical Behavior*, 17(1), 105-121.
- Evapmib (2007). *Une base se questions d' evaluations en mathématiques*. Retrieved March 25, 2007, from <http://ctug48.uni-fcomte.fr/evapmib/siteEvapmib/accueil.php>

- Gagatsis, A., Elia, I. & Mougi, A. (2002). The nature of multiple representations in developing mathematical relations. *Scientia Paedagogica Experimentalis*, 39(1), 9-24.
- Hitt, F. (1998). Difficulties in the articulation of different representations linked to the concept of function. *The Journal of Mathematical Behavior*, 17(1), 123-134.
- Keijzer, R., & Terwel, J. (2003). Learning for mathematical insight: a longitudinal comparative study on modeling. *Learning and Instruction*, 13, 285 – 304.
- Lesh, R., Post, T., & Behr, M. (1987). Representations and translations among representations in mathematics learning and problem solving. In C. Janvier (Ed.), *Problems of representation in the teaching and learning of mathematics*, (pp. 33-40). Hillsdale, N.J.: Lawrence Erlbaum Associates.
- Michaelidou, N., Gagatsis, A., & Pitta- Pantazi, D. (2004). The number line as a representation of decimal numbers: A research with sixth grade students. In M. J. Hoines & A. B. Fuglestad (Eds.), *Proceedings of the 28th Conference of the International Group for the Psychology of Mathematics Education* (Vol. 3, pp. 305 – 312). Bergen, Norway: PME.
- National Council of Teachers of Mathematics (2000). *Principles and standards for school mathematics*. Reston, Va: NCTM.
- Polya, G. (1957). *How to solve it*. New York: Doubleday.
- Smith, J.P. (2002). The development of students' knowledge of fractions and ratios. In B. Litwiller & G. Bright (Eds.). *Making sense of fractions, ratios and proportions* (pp. 3 – 17). Reston, Va: NCTM.

Appendix

1. Circle the diagram or the diagrams whose shaded part corresponds to the equation $\frac{3}{14} + \frac{5}{14}$.

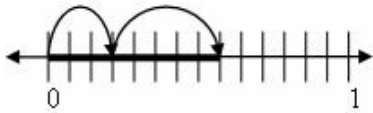

(RELa)

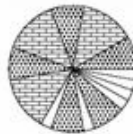

(RECa)



(RERa)

2. $\frac{1}{6} + \frac{4}{12} = \dots$ (TRSb)
 3. Write the fraction equation that corresponds to the shaded part of the following diagram:



Equation: (CORSD)

4. Present the following equation on the diagram:

$\frac{1}{12} + \frac{7}{12} = \dots$

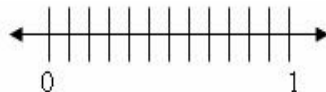

(COFSLs)

5. In the addition of two fractions whose numerator is smaller than the denominator, the sum may be bigger than the unit. Do you agree with this view? Explain. (JV)
 6. Each kind of flower is planted in a part of the rectangular garden as it appears in the diagram below:

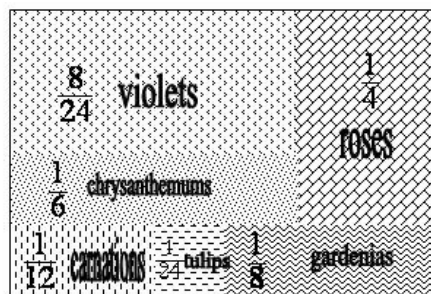

Which three kinds of flowers are planted in the $\frac{3}{4}$ of the garden?(PD)

7. A juice factory produces the following kinds of natural juice:

- $\frac{1}{4}$ of the production is grapefruit juice.
- $\frac{5}{18}$ of the production is orange juice.
- $\frac{3}{36}$ of the production is tomato juice.
- $\frac{2}{9}$ of the production is peach juice.

- $\frac{1}{18}$ of the production is grapes juice.
- $\frac{4}{36}$ of the production is apple juice.

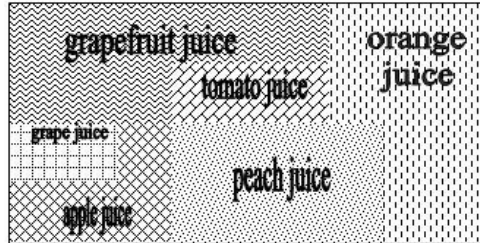

Which four kinds of juice make up $\frac{1}{2}$ of the production? (PVD)

8. The manager of a circus is preparing the performance that will be given in a few days. He wrote the duration of each program in his notes: Clowns: $\frac{1}{2}$ hour, Dancers: $\frac{1}{3}$ hours, Animals: 1 hour, Acrobats: $\frac{1}{6}$ hour, Jugglers: $\frac{2}{1}$ hour

Write as a fraction, what part of the total duration of the performance corresponds to the jugglers' program (PV, Evapmib, 2007).



The role of verbal description, representational and decorative picture in mathematical problem solving

Sofia Agathangelou, Athanasios Gagatsis & Veronika Papakosta

Department of Education, University of Cyprus

Abstract

This study investigates the role of representational and decorative picture in solving one-step mathematical problems of the additive structure with the unknown in the first part (a) by primary second grade students. It also investigates pupils' attitude towards the use and the role of pictures. For the purposes of the study, 125 pupils were asked to complete a questionnaire with two verbal problems, two problems accompanied by a representational picture and two by a decorative one. The results indicate that the presence of both the representational and the decorative picture did not have a significant impact in pupil's performance, even though pupils' attitude towards them is positive.

Theoretical and empirical background

Introduction

Last decades a great attention has been given on the concept of representation and its role in the learning of mathematics. A basic reason for this emphasis is that representations are considered “integrated” with mathematics (Kaput, 1987). This study aims to shed light on the influence of two types of representation on additive problems. Specifically, we investigate the role of representational and decorative pictures. These are contrasted to each other and to the use of plain verbal description (written text) for the solution of one-step addition problems presented in a number of different structures to be described below. Specifically, below we first discuss the nature and possible effects of different types of representation of arithmetic problems and then the different structures in which these problems may be presented.

Representations in mathematics learning

A representation is defined as any configuration of characters, images and concrete objects that can symbolize or “represent” something else (Kaput, 1985; Goldin, 1998; DeWindt-King & Goldin, 2003). Kaput (1987) suggested that the concept of representation involves the following five components: A representational entity, the entity that it represents, particular aspects of the representational entity, the particular aspects of the entity that it represents that form the representation and finally the correspondence between the two entities.

A basic discrimination that is pointed out in the region of representations is between internal/mental and external/semiotic representations (Dufour – Janvier et al., 1987). Internal/mental representations are mental schemes constructed by individuals in order

to represent, explain and understand reality. External/semiotic representations are external symbolic carriers, such as symbols, shapes and diagrams, which aim at representing a specific reality, for example mathematics. Goldin and Kaput (1996) suggest that there is a dual, two-way relationship between external/semiotic and internal/mental representations.

A type of external representation that is used extensively in mathematics textbooks and is considered to enhance problem solving in all the phases of the certain process is visual representations (Larkin & Simon, 1987). Schnotz (2002) suggests that text and visual displays belong to different classes of representations, namely descriptive and depictive representations, respectively. Descriptive representations consist of symbols that have an arbitrary structure and are associated with the content they represent simply by means of a convention. Depictive representations include iconic signs that are associated with the content they represent through common structural features on either a concrete or a more abstract level.

In mathematics education, visual representations play an important role both as an aid for supporting reflection and as a means for communicating mathematical ideas. Therefore, many researchers consider imagistic representations as a fundamental cognitive system for mathematical learning (DeLoache, 1991) and problem solving (De Windt-King & Goldin, 2003; Diezmann & English, 2001), while experts mathematicians as well as mathematics students perceive visual representations as a useful tool in Mathematical Problem Solving (MPS) and frequently attempt to use them (Stylianou, 2001).

However, the use of pictorial representations may not have the intended effects due to obstacles they may cause to mathematics learning and problem solving (Bishop, 1989). For instance, these representations may divert attention to irrelevant details and they may highlight some aspects of the problem at the expense of others, more relevant to the task requirements (Colin, Chauvet, & Viennot, 2002; Presmeg, 1986). Moreover, a pictorial representation may fail to help in an educational setting, such as mathematical problem solving, when students do not understand how the representation is related to its referent (DeLoache, Uttal, & Pierroutsakos, 1998).

Given that a representation cannot describe fully a mathematical construct and that each representation has different advantages, using multiple representations for the same mathematical situation is at the core of mathematical understanding (Duval, 2002). Three presuppositions for the mastery of a concept in mathematics are the following: First, the ability to identify the concept in multiple systems of representation; second, the ability to handle flexibly the concept within the particular systems of representation; and third, the ability to “translate” the concept from one system of representation to another (Lesh, Post & Behr, 1987). Principles and Standards for School Mathematics (NCTM, 2000) include a standard referring exclusively to representations and stress the importance of the use of multiple representations in mathematics learning. Ainsworth,

The role of verbal description, representational and decorative picture in problem solving

Bibby, and Wood (1997) suggest that the use of multiple representations can help students develop different ideas and processes, constrain meanings and promote deeper understanding. By combining representations students are no longer limited by the strengths and weaknesses of one particular representation. For example, we use pictures in mathematics textbooks to increase the “readability” of standard mathematical expressions. However, interacting with multiple representations requires the understanding of the relationship between them. This is a complex process. Research shows that students encounter difficulty in integrating information from different sources (Case & Okamoto, 1996; Demetriou, Christou, Spanoudis, & Platsidou, 2002) or in moving from one representation of a mathematical object to another. As a result, they tend to use representations in isolation (Ainsworth, 2006; Duval, 2002).

Although, the mental processes, and particularly the visual-spatial images, used in MPS or mathematics learning have received extensive research in the field of mathematics education (e.g., Presmeg, 1992; Gusev, & Safuanov, 2003), the role of pictorial representations or number line in MPS, has received much less attention (Gagatsis & Elia, 2004). An effort to study the function of pictorial representations was made by Carney and Levin (2002) who proposed five functions that pictures serve in text processing – decorative, representational, organizational, interpretational and transformational. Given Carney and Levin’s (2002) five functions that pictures serve in text, Theodoulou, Gagatsis & Theodoulou (2003) proposed a similar categorization for the functions of pictures in MPS. Specifically, they suggested that pictures have the following four functions in MPS: (a) decorative, (b) auxiliary-representational, (c) auxiliary-organizational and (d) informational.

Decorative pictures do not provide any actual information concerning the solution of the problem, but simply decorate the page bearing little or no relationship to the problem content. Auxiliary-representational pictures represent part or all of the problem content, but are not necessary to be used in order to solve the problem. Auxiliary-organizational pictures help the students to solve the problem by guiding them to organize the given statements of the problem. Finally, informational pictures provide information that is essential for the solution of the problem; in other words, the problem is based on the picture.

Recent researches tried to examine the role of specific types of pictures in MPS. A first research by Gagatsis and Markou (2002) showed that the incorporation of decorative pictorial representations in unused verbal problems did not lead to a change in students’ behavior towards these problems, thus not breaching of the didactical contract. Pupils ignored the existence of pictures and their attention was detracted by the numerical data in the problem statement.

Theodoulou, Gagatsis and Theodoulou (2004) examined the role of the four different types of pictures according to their function in MPS. The results showed that the presence of decorative and informational pictures had no significant effect on students’

problem solving performance, whereas auxiliary-organizational pictures had a significant positive effect. Auxiliary-representational pictures had a significant positive effect in some cases, according to the mathematical operations needed in order to solve the problem. It was also found that the kind of mathematical operation needed in order to solve the problem had a more significant effect on students' problem solving performance than the kind of picture that accompanied the problem. In many cases, although the children used the picture in order to solve a problem, they claimed that the picture was not useful for solving the problem.

Elia and Philippou (2004) explored the role of pictures based on their function, in the solution of non-routine problems by pupils of Grade 6, in the context of an experimental model of communication. Findings of the particular study revealed that the representational, informational and organizational picture, but not the decorative one, had a significant effect on MPS.

Elia, Gagatsis and Demetriou (2007) investigated the role of the four different types of representation in MPS and developed a model, which provided information about the structural organization underlying students' processes in the solution of one-step additive problems in multiple representations. This model involved four first-order representation-specific factors indicating the differential effects of each particular type of representation and a second-order factor representing the general ability to solve additive problems. The size of the factor coefficients of the proposed model indicated that pupils' general problem solving ability was highly associated with the abilities in solving problems in verbal form, with decorative pictures and number line. This finding suggested that students used similar processes to solve the problems in the three modes of representation, indicating that pupils overlooked the presence of the line or the decorative picture and gave attention only to the text of the problem. The decorative pictures had no impact on students' behavior in MPS. The informational pictures had a rather complex role in problem solving compared to the use of the other modes of representation. It is possible that it required extra and more complex mental processes relative to the other modes of representation, since it involved not only pictorial but verbal information as well (Pyke, 2003).

According to the studies of Deliyianni, Gagatsis and Koukkoufis (2003), and Gagatsis and Andronicou (2004), similar results occurred in the case of representational pictures. To be specific, it appeared that pupils certain times did not take them into consideration since their use was not essential for MPS. Thus, representational pictures were very often tackled in a similar way the verbal problems were tackled, presenting, as a consequence, the same degree of difficulty. On the other hand, the problems accompanied with organizational pictures seemed to be solved more easily by the pupils. Nevertheless, the presence of organizational pictures in the context of some problems made the solution of them more complicated. That is because the pupils could resolve these problems successfully without any picture. Certain times organizational pictures provided pupils with unnecessary directions for drawing or written work.

Besides, even though some pupils partly drew and wrote correctly what was asked for in the organizational picture, they were still unable to go on to the correct mathematical equation. A likely explanation is that no one can guarantee that pupils will conceive the symbolic relation between the representation and the entity in which it corresponds (DeLoache, Uttal & Pierroutsakos, 1998).

To sum up, in a comparative article of a number of studies related to the contribution of pictures and number line in MPS, Gagatsis and Deliyianni (2004), provided evidence for the non-significant role of the decorative picture, the negative effect of the informational picture, the ambiguous role of the representational picture and the positive influence of the organizational picture on students' performance in MPS.

Considering the research studies reported here, due to the fact that they were conducted in different settings, with various age samples, using distinct research methods, some of their findings are congruent, whereas others are incompatible. However, these investigations seem to concur with an important assertion: that apart from the nature of the notion involved in a mathematical task, such as the structure or the content of a problem, the different modes of representation do have an effect on students' performance. This suggests that problem solving, which is a major dimension of mathematical learning endeavor, and probably other mathematical activities as well, incorporate an important interaction between the mode of representation and the mathematical structure or the inherent mathematical properties involved (Monoyiou, Spagnolo, Elia & Gagatsis, 2007).

As regards the effects of visual representations, in some cases the presence of visual representations in addition to verbal ones was found to have a helpful role on students' performance. In other cases, visual representations were found not to differentiate at all students' performance or even to impede their solutions. This variation of the visual representations' impact is due to several factors. A number of these factors concern the types of visual representations and specifically their nature, structure and complexity; the mathematical concepts involved in the task; the relation or correspondence of the visual representations with the concepts or situations they represent; and students' features, such as their cognitive styles, familiarity with the representations and generally existing knowledge (Monoyiou, Spagnolo, Elia & Gagatsis, 2007). In the light of the above, the use of visual representations in mathematical teaching and learning is a multidimensional and complicated process and should be conducted with great attention (Seeger, 1998). Reading and using images constitute skills that should not be left to chance, but should be taught systematically (Dreyfus & Eisenberg, 1990) and not in isolation, but in association with linguistic representations.

Regarding the role of pupils' emotions and attitudes towards the use of pictures in MPS, De Bellis & Goldin (2006) supported that affect constitutes an internal representational system. According to their model, the person's ability to solve mathematical problems is based on five kinds of internal, mutually interacting systems of representation. One of

these systems is the affective, which refers to the person's emotions, attitudes, beliefs, morals, values, and ethics. In the research they conducted, De Bellis & Goldin (2006) found that the affective domain can enhance or undermine pupils' performance in Mathematics.

Structures of addition problems

Researchers have analyzed the structure of one-step word problems and highlighted its role in the solution strategies employed by students (Christou & Philippou, 1998). Previous studies on one-step additive problems have identified three main types of semantic structures: change or transformation of a measure, combine or composition of two measures and compare two measures to each other (Nesher, Greeno, & Riley, 1982; Vergnaud, 1982). In the present study, we focused on one class of problems: one-step composition problems.

Empirical evidence suggests that problems within the same semantic category vary in difficulty, since the placement of the unknown influences students' strategies and performance (Carpenter & Moser, 1984; Nesher et al., 1982). In the present study, we explore the use of two other modes of representation in addition to the verbal description. Specifically, we examine the role of decorative and representational pictures, on additive problem solving.

The study

Purpose

The purpose of this study was to investigate the role of three different modes of representation (decorative picture, representational picture and verbal description – text) in MPS. More specifically the aim of the study was to explore and compare the effects of decorative and representational picture in the solution procedures of one-step problems of the additive structure. Furthermore, the study aimed to identify the pupils' attitudes towards the use and the role of pictures in MPS.

Methodology

Participants



The sample of the research consisted of 125 second grade (7 to 8 years old) students (70 boys and 55 girls) from four elementary schools in two districts of Cyprus. The sample was selected with convenience sampling method. The students were acquainted with one-step problems of the additive structure from the first grade of elementary school. Also, they were exposed to teaching using verbal, decorative and representational pictures before through their textbooks and school materials.

The role of verbal description, representational and decorative picture in problem solving

Data collection

In order to collect the data needed for this study, a questionnaire was constructed. The questionnaire consisted of 6 one-step grouping (part – part – whole) problems with additive structures ($a+b=c$), based on the classification of problems with additive structures proposed by Vergnaud (1982). More specifically, the focus was on situations with the placement of the unknown in the first part (a) because, in this case, the problem is considered to be more difficult. The problems were accompanied with or represented in different representational modes. All the categories of problems are presented in the following table.

Table 1: Specification Table of the problems included in the test

Type of representation	Problem	Example
Verbal	1, 4	Helens' classroom has some boys and 7 girls. All the children are 13. How many boys are there in Helens' classroom?
Representational picture	2, 5	<p style="text-align: right;"><input type="text"/> boys</p> <p>Costas cut some roses and 5 marguerites. All the flowers he cut were 11. How many roses did he cut?</p> <div style="text-align: center;">  </div> <p style="text-align: right;"><input type="text"/> roses</p>
Decorative picture	3, 6	<div style="text-align: center;">  </div> <p>At the birthday party of Carina were some red and 9 yellow balloons. All the balloons were 13. How many red balloons were at the party?</p> <p style="text-align: center;"><input type="text"/> red balloons</p>

Furthermore in the test, there were questions relative to the students' attitude towards the presence and the role of the different representational modes in MPS. Those questions were answered by choosing either "Yes" or "No".

Procedure

The written questionnaire was administered to the students in usual classroom conditions. Students were asked to solve all the items explaining their solution strategies. They were not obliged to use the pictures that accompanied the problems. Actually, they were instructed to use the representations if they believed that they could help them resolve the problems. Students were given 40 minutes to solve the problems. After the completion of the problem tasks, the questionnaires were collected.

Scoring of the tasks

Problem tasks were scored as follows: 0=wrong answer or no answer, 1=correct answer. Relatively to the questions, which concerned the use of the pictures by the students and their attitude towards them, affirmative answers were marked as 1 and negative answers were marked as 0.

Variables of the study

The variables of the study were the following:

- V1, V2: Verbal problem
- Iv1, Iv2: Problem solving by drawing a representational picture
- Sv1, Sv2: Problem solving by using mathematical symbols
- R1, R2: Problem accompanied with representational picture
- Ir1, Ir2: Problem solving by using representational picture
- D1, D2: Problem accompanied with decorative picture
- Id1, Id2: Problem solving by using decorative picture
- Idr1, Idr2: Students solve the problem which is accompanied with decorative picture by drawing a representational picture
- A1: Students' attitude towards the pictures
- Be1: Students' opinion about the assistant role of the pictures in MPS

Method of analysis

Multiple methods of analysis were performed, using the collected data, including Descriptive Statistics Analysis by using the computer software SPSS and Gras's Implicative Analysis by using the computer software C.H.I.C (Classification Hiérarchique, Implicative et Cohésitive) (Bodin, Coutourier & Gras, 2000). Gras's Statistical Model is a method appropriate for collecting and analyzing data in order to reinforce or refute hypotheses and draw conclusions. This method determines the connections and the implicative relations of factors. The similarity diagram allows for the arrangement of tasks into groups according to their homogeneity. The implicative method gives the implicative graph, which represents the implicative relations among all variables which indicate whether success in one task entails success in another task

related to the former one. The implications are valid at a level of significance of 99%, 95% or 90%.

Results

Students' performance on problem tasks accompanied with different representational modes.

A basic aim of the study was to examine whether different modes of representation (decorative picture, representational picture and verbal description – text) affect second grade students' performance in solving one-step problems of the additive structure. Table 2 shows the students' performance on the six problem tasks of the questionnaire. The highest percentage (95%) is observed when the problem is accompanied with representational picture (R1), whilst the lowest percentage (76%) refers to the verbal problem (V2) and to the problem which is accompanied with decorative picture (D2). The results show that the percentages are high in all the problem tasks. Therefore, students' performance is not altered by the mode of representation used.

Table 2: Students' performance on addition problems accompanied with different representational modes

Variables	V1	V2	R1	R2	D1	D2
Percentage of Success	82 %	76 %	95 %	78 %	77 %	76 %

Use of decorative and representational pictures

A second aim of the study was to examine whether students use the decorative and representational pictures when they solve one-step grouping (part – part – whole) problems of additive structure. Table 3 shows the percentages of students who declare that they used pictures to solve the mathematical problems. Students mention that they used more the representational pictures (Ir1 =67%, Ir2 = 62%) and less the decorative ones (Id1=31%, Id2=32%). From Table 3 it is also evident that few students draw a picture on verbal problems (Iv1= 2%, Iv2=3%) or solve problems which are accompanied with decorative picture by drawing a representational picture (Idr1= 3%, Idr2= 4%).

Table 3: Percentages of picture use.

Variables	Iv1	Iv2	Ir1	Ir2	Id1	Id2	Idr1	Idr2
Percentage of use	2 %	3 %	67 %	62 %	31 %	32 %	3 %	4 %

Students' attitude towards decorative and representational pictures

The study also aimed to investigate students' attitude towards decorative and representational pictures. As shown in Table 4, students seem to have a positive attitude to the presence and the role of decorative and representational pictures in MPS.

Table 4: Students' attitude towards decorative and representational pictures.

Variables	A1	Be1
Percentage	71 %	73 %

Similarity between the tasks

The Similarity Diagram (Figure 1) shows how tasks are grouped according to the similarity of the ways in which they have been solved. The similarities in bold color are important at level of significance 99%.

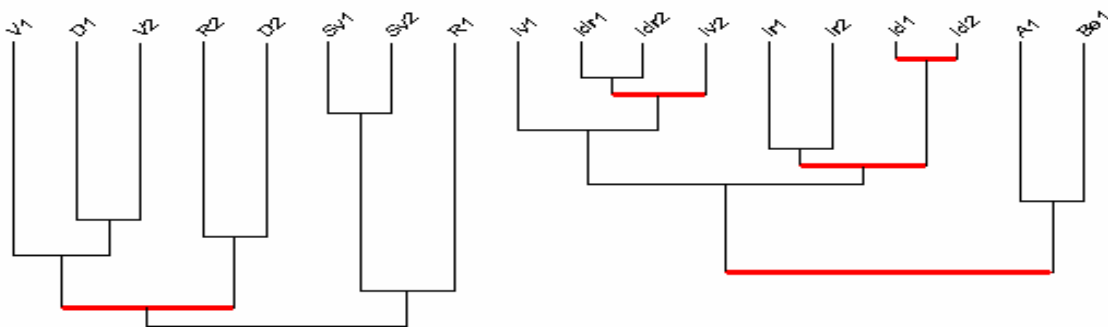

Figure 1: Similarity diagram of students' responses to the tasks

According to the Similarity Diagram (Figure 1), two groups are clearly distinguished. The first group consists of the variables V1, D1, V2, R2, D2, Sv1, Sv2 and R1, which represent students' efficiency in solving the problem tasks and using mathematical symbols. The variables Iv1, Idr1, Idr2, Iv2, Ir1, Ir2, Id1, Id2, A1 and Be1 are included in the second similarity group that concerns solving the problem tasks by using pictures and also students' attitudes and beliefs towards pictures.

In the first group, two subgroups are distinguished. The first subgroup consists of the variables V1, D1, V2, R2 and D2 which represent the students' efficiency in solving the addition problems. The second subgroup consists of the variables Sv1, Sv2 and R1. The connection between Sv1 and Sv2 is not surprising, as these variables represent students' tendency to solve verbal problems by using mathematical symbols and equations.

In the second group two subgroups are also distinguished. The first subgroup consists of all problem tasks which students solved by using decorative and representational pictures (Iv1, Idr1, Idr2, Iv2, Ir1, Ir2, Id1 and Id2). The second subgroup consists of the variables which represent students' attitudes and beliefs towards pictures (A1, Be1).

According to the similarity diagram, the most significant similarity relationships can be observed between the variables of the second group. For example the variables Id1 and Id2 are connected with the most significant relationship. Thus, students justifiably behaved in a similar way when they solved the addition problems which were accompanied with a decorative picture. Furthermore, the variables Id1 and Id2 are significantly connected with the variables Ir1 and Ir2. This connection is not surprising because some of the students who declared that they used the decorative pictures to solve the problem tasks, they did the same for the representational pictures.

Moreover, significant similarity relationship can be observed between the variables Idr1, Idr2 and Iv2 which represent the cases in which students solved the verbal problems or the problems which were accompanied with decorative picture, by drawing a representational picture. This behavior can be considered as systematic because, students who need and draw representational pictures to solve verbal problems, do the same for the problems which are accompanied with decorative picture. However, as shown in Table 3, this behavior can be observed rarely.

Considering the similarity diagram, there is a similarity connection between the variables Iv1, Idr1, Idr2, Iv2, Ir1, Ir2, Id1, Id2 (group 1) and the variables A1, Be1 (group 2). This connection is expected, because students who use pictures to solve addition problems, have a positive attitude towards them.

Furthermore, as shown in the Similarity Figure, there is no similarity relationship between the two groups. This finding indicates that picture use and students attitudes towards them are not connected with students' performance in solving one-step problems of the additive structure.

Implicative Graph

The Implicative Graph (Figure 2) shows the implications between problem tasks, questions which referred to picture use and questions which referred to students' attitude towards pictures. The implications are important at level of significance 90%, 95% and 99%, according to the thickness of the line.

According to the Implicative Graph (Figure 2), variables which referred to the picture use on problem tasks which were accompanied with representational and decorative image (Id1, Id2, Ir1, Ir2), are connected with implicative relationships. From Figure 2 it can be concluded that students who use the decorative pictures (Id1, Id2), use also representational pictures (Ir1, Ir2) to solve the addition problems. This finding is in agreement with the percentages shown in Table 3 which indicate that more students use representational than decorative pictures.

It is also evident that picture use (Id1, Id2, Ir1, Ir2) entails positive attitude towards them (A1, Be1). Concretely, students who solve the problem tasks by using either

decorative or representational picture, refer that they like pictures because they help them in problem solution.

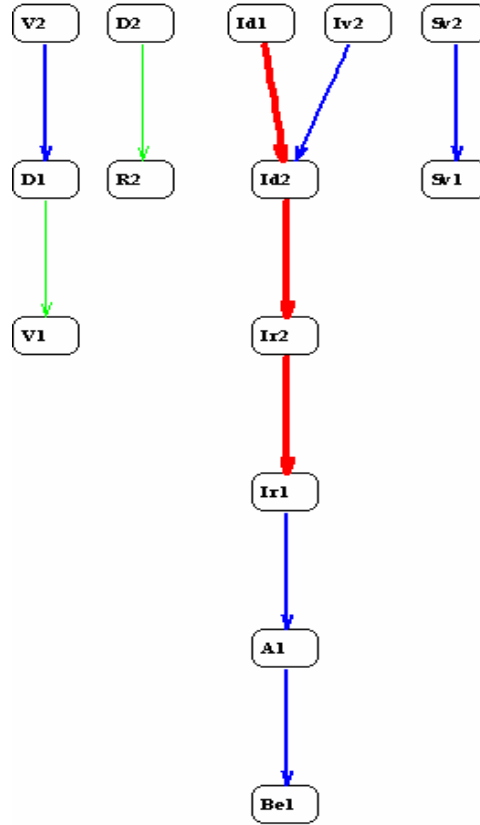

Figure 2: Implicative graph of students' responses to the tasks

Discussion

The gap in the research literature on the role of pictures in MPS (Gagatsis & Elia, 2004) contributed to conduct this study. Based on the functions that pictures serve in text processing, as proposed by Carney and Levin (2002), this study attempted to examine the role of decorative and representational picture in solving mathematical problems of the additive structure with the unknown in the first part (a). Moreover, considering that the affective domain can enhance or undermine pupils' performance in Mathematics (De Bellis & Goldin, 2006), we also focused on the role of pupils' emotions and attitudes towards the use of pictures in MPS.

A basic aim of the study was to investigate the role of decorative and representational pictures in solving one-step grouping (part – part – whole) problems with additive structures. As the results have shown, students' performance in MPS is not affected by the presence and use of decorative and representational pictures. This finding coincides with the findings of a previous study by Gagatsis et al (1999), which showed that

different modes of representation, such as pictures, do not always assure successful overlapping of cognitive difficulties in Mathematics.

In this study we also examined the relation between students' performance and the nature of the representation (decorative or representational pictures) used. It is evident that the success percentages are high enough in all the problem tasks. Therefore students' performance is not altered according to the mode of representation used. This finding is in agreement with the results of a previous study by Gagatsis and Marcou (2002) which showed that decorative pictures did not lead to a change in students' behavior towards non-routine verbal problems. These results also support Theodoulou, Gagatsis and Theodoulou's (2004) conclusions that auxiliary-representational pictures had a significant positive effect only in some cases.

As regards the decorative picture, it seems that decorative pictures have no impact on pupils' behavior in MPS. It is also remarkable the fact that pupils sometimes draw a representational picture in order to solve a problem which is accompanied with decorative picture. Thus, Carney and Levin's (2002) opinion that decorative pictures do not enhance any understanding or application to the text appears to extend itself in the case of mathematical problems.

The results have also shown that students attitudes towards the role and use of pictures is not connected with their performance in MPS. Further research is needed to investigate the relationship between pictorial representations and affect, which constitutes an internal representational system according to De Bellis and Goldin (2006), in order to conclude that the affective domain can enhance or undermine pupils' performance in Mathematics.

References

- Ainsworth, S. (2006). DeFT: a conceptual framework for considering learning with multiple representations. *Learning and Instruction, 16*, 183 - 198.
- Ainsworth, S., Bibby, P., & Wood, D. (1997, August). *Evaluating principles for multi-representational learning environments*. Paper presented at the 7th European Conference for Research on Learning and Instruction, Athens, Greece.
- Bishop, A. (1989). Review of research on visualization in mathematics education. *Focus on Learning Problems in Mathematics, 11*(1), 7 - 15.
- Bodin, A., Coutourier, R., & Gras, R. (2000). *CHIC: Classification Hiérarchique Implicative et Cohésive-Version sous Windows – CHIC 1.2*, Association pour la Recherche en Didactique des Mathématiques Rennes.
- Carney, N.R., & Levin, R.J. (2002). Pictorial illustrations still improve students' learning from text. *Educational Psychology Review, 14*(1), 5-26.

- Carpenter, T. P., & Moser, J. (1984). The acquisition of addition and subtraction concepts in grades one through three. *Journal for Research in Mathematics Education*, 15, 179 - 202
- Case, R., & Okamoto, Y. (1996). The role of conceptual structures in the development of children's thought. *Monographs of the Society for Research in Child Development*, 61 (1-2). (Serial no. 246).
- Christou, C., & Philippou, G. (1998). The developmental nature of ability to solve one-step word problems. *Journal for Research in Mathematics Education*, 29(4), 436 - 442.
- Colin, P., Chauvet, F., & Viennot, L. (2002). Reading images in optics: students' difficulties and teachers' views. *International Journal of Science Education*, 24(3), 313 - 332.
- De Bellis, V. A. & Goldin, G.A. (2006). Affect and Meta-Affect in Mathematical problem Solving: A Representational Perspective. *Educational Studies in Mathematics*, 63(2), 131 - 147.
- Deliyianni, E., Gagatsis, A., & Koukkoufis, A. (2003). The effect of pictures in multiplication problem solving by Grade 3 students. In A. Gagatsis & I. Elia (Eds.), *Representations and geometrical models in mathematics learning* (Vol. I, pp.87-104). Lefkosia: Intercollege Press (in Greek).
- DeLoache, J. S. (1991). Symbolic functioning in very young children: understanding of picture and models. *Child Development*, 62(4), 736 – 752.
- DeLoache, J. S., Uttal, D. H., & Pierroutsakos, S. L. (1998). The development of early symbolization: Educational implications. *Learning and Instruction*, 8(4), 325-339.
- Demetriou, A., Christou, C., Spanoudis, G., & Platsidou, M. (2002). The development of mental processing: efficiency, working memory, and thinking. *Monographs of the Society of Research in Child Development*, 67. (Serial no. 268).
- DeWindt-King, A.M., & Goldin, G.A. (2003). Children's visual imagery: Aspects of cognitive representation in solving problems with fractions. *Mediterranean Journal for Research in Mathematics Education*, 2(1), 1-42.
- Diezmann, C., & English, L. (2001). *The roles of representation in school mathematics: 2001 YearBook*. Virginia: NCTM.
- Dreyfus, T., & Eisenberg, T. (1990). On difficulties with diagrams: Theoretical issues. In G. Booker, P. Cobb & T.N. De Mendicuti (Eds.), *Proceedings of the 14th Annual Conference of the International Group for the Psychology of Mathematics Education*. Vol. 1 (pp. 27-36). Oaxtepec: PME.
- Dufour-Janvier, B., Bednarz, N., & Belanger, M. (1987). Pedagogical considerations concerning the problem of representation. In C. Janvier (Ed.), *Problems of Representation in the Teaching and Learning of Mathematics* (pp.109-122). Hillsdale, NJ: Lawrence Erlbaum.

- Duval, R. (2002). The cognitive analysis of problems of comprehension in the learning of mathematics. *Mediterranean Journal for Research in Mathematics Education*, 1(2), 1 - 16.
- Elia, I., Gagatsis, A., & Demetriou, A. (2007). The effects of different modes of representation on the solution of one-step additive problems. *Learning and Instruction*, 17, 658-672.
- Elia, I., & Philippou, G. (2004). The functions of pictures in problem solving. In M. Johnsen Hoines & A. Berit Fuglestad (Eds.), *Proceedings of the 28th Conference of the International Group for the Psychology of Mathematics Education, Vol. 2* (pp. 327-334). Bergen, Norway: Bergen University College.
- Gagatsis, A., & Andronicou, E. (2004). The effect of pictures in division problem solving. In A. Gagatsis (Ed.), *Contemporary trends in Didactics of Mathematics* (pp.83-97). Lefkosia: University of Cyprus & UNESCO, (in Greek).
- Gagatsis, A., & Deliyianni, E. (2004). Pictures, number line and solution of problems of the four number facts: A comparative study. In A. Gagatsis, A. Evangelidou, I. Elia & P. Spyrou (Eds.), *Representations and learning in mathematics: Problem solving, models and functions, Vol. 1*, (pp.133-165). Lefkosia: Inercollege Press, (in Greek).
- Gagatsis, A., Demetriou A., Afantiti, T., Michaelidou, E., Panaoura, R., Siakalli, M., & Christoforides, M. (1999). L'influenza delle rappresentazioni semiotiche. nella risoluzione de problemi additivi. *La matematica e la sua didattica*, 3, 382 - 403.
- Gagatsis, A., & Elia, I. The effects of different modes of representations on mathematical problem solving. In M. Johnsen Hoines & A. Berit Fuglestad (Eds.), *Proceedings of the 28th Conference of the International Group for the Psychology of Mathematics Education, Vol. 2* (pp.447-454). Bergen, Norway: Bergen University College, (2004).
- Gagatsis, A., & Markou, A. (2002). Representations and learning of Mathematics: Two sides of the same coin? In a. Gagatsis, L. Kyriakides, N. Tsaggaridou, E. Ftiaka & M. Koutsoulis (Eds.), *Proceedings of the Seventh Conference of the Cypriot Pedagogical Association: The Educational Research in the Era of Globalization, Vol. B* (pp. 263-287). Nicosia: Pedagogical Association of Cyprus, (in Greek).
- Goldin, G.A. (1998). Representational systems, learning, and problem solving in mathematics. *Journal of Mathematical Behavior*, 17(2), 137 - 165.
- Goldin, G.A., & Kaput, J. J (1996). A joint perspective of the idea of representation in learning and doing mathematics. In von L. P. Steffe & Mahwah (Eds.), *Theories of Mathematical Learning* (pp. 397 - 430). Hillsdale, NJ: Lawrence Erlbaum.
- Gusev, V., & Safuanov, I. (2003). Thinking in images and its role in learning mathematics. In N. Pateman, B. Dougherty & J. Ziliox (Eds.), *Proceedings of the 2003 Joint Meeting of PME and PMENA, Vol. 4* (pp. 87-94). Honolulu: University of Hawaii.

- Kaput, J.J. (1985). Representation and problem solving: methodological issues related to modelling. In E.A. Silver (Ed.), *Teaching and Learning Mathematical Problem Solving: Multiple Research Perspectives* (pp. 381-398). Hillsdale, NJ: Erlbaum.
- Kaput, J. J. (1987). Representation Systems and Mathematics. In C. Janvier (Ed.), *Problems of Representation in the Teaching and Learning of Mathematics* (pp. 19-26). Hillsdale, NJ: Lawrence Erlbaum.
- Larkin, J. H., & Simon, H. A. (1987). Why a diagram is (sometimes) worth ten thousand words. *Cognitive Science*, 11, 65-99.
- Lesh, R., Post, T. and Behr, M. (1987). Representations and translations among representations in mathematics learning and problem solving. In C. Janvier (Ed.), *Problems of Representation in the Teaching and Learning of Mathematics*, (pp. 33-40). Lawrence Erlbaum, Hillsdale, NJ.
- Monoyiou, A., Spagnolo, F., Elia, I., & Gagatsis, A. (2007). Visual Representations in Mathematics Education. In E.P. Avgerinos & A. Gagatsis (Eds.). *Current Trends in Mathematics Education*, (pp. 127- 139). Rhodes: Cyprus Mathematics Society & University of Aegean.
- National Council of Teachers of Mathematics (2000). *Principles and Standards for School Mathematics*. Reston, Va: NCTM.
- Nesher, P., Greeno, J. G., & Riley, M. S. (1982). The development of semantic categories for addition and subtraction. *Educational Studies in Mathematics*, 13, 373 - 394.
- Presmeg, N. C. (1986). Visualisation in high school mathematics. *For the Learning of Mathematics*, 6(3), 42 - 46.
- Presmeg, N. C. (1992). Prototypes, metaphors, metonymies and imaginative rationality in high school mathematics. *Educational Studies in Mathematics*, 23, 595 - 610.
- Pyke, L. (2003). The use of symbols, words and diagrams as indicators of mathematical cognition: A causal model. *Journal for Research in Mathematics Education*, 34(5), 406-432.
- Schnotz, W. (2002). Towards an integrated view of learning from text and visual displays. *Educational Psychology Review*, 14(1), 101 - 120.
- Seeger, F. (1998). Representations in the mathematical classroom: Reflections and constructions. In von F. Seeger, J. Voigt & U. Waschescio (Eds.), *The culture of the mathematics classroom* (pp.308-343). Cambridge: Cambridge UP.
- Stylianou, D. (2001). On the reluctance to visualize in mathematics: Is the picture changing? In M. van den Heuvel-Panhuizen (Ed.), *Proceedings of the 25th Conference of the International Group for the Psychology of Mathematics Education*, Vol. 4 (pp.225-232). Utrecht, The Netherlands: Freudenthal Institute.

The role of verbal description, representational and decorative picture in problem solving

- Theodoulou, R., Gagatsis, A., & Theodoulou, A. (2003). Are pictures always helpful in mathematics problem solving? In A. Gagatsis & I. Elia (Eds.), *Representations and Geometrical models in the Learning of Mathematics, Vol. I* (pp. 67-85). Nicosia: Intercollege Press, (in Greek).
- Theodoulou, R., Gagatsis, A., & Theodoulou, A. (2004). Un' imagine vale piu di mille parole...Ma che tipo di imagine risulta piu efficace nell attivita di problem solving matematico degli studenti?, *La matematica e la sua didattica*, 2, 4 - 32.
- Vergnaud, G. (1982). A classification of cognitive tasks and operations of thought involved in addition and subtraction problems. In J. P. Carpenter, J. M. Moser, & T. A. Romberg (Eds.), *Addition and subtraction: A cognitive perspective* (pp. 39-59). Hillsdale, NJ: Lawrence Erlbaum.



Misconceptions and Semiotics: A comparison

George Santi

*N.R.D., Bologna, Italia
Università di Palermo, Italia*

Silvia Sbaragli

*N.R.D., Bologna, Italia
Università di Bologna e Bolzano, Italia
Alta Scuola Pedagogica, Locarno, Svizzera*

Abstract

Following D'Amore's constructive interpretation for the term misconception, we propose a semiotic approach to misconceptions, within the theoretical frameworks proposed by Raymond Duval and Luis Radford.

Introduction

In this article we deal with one of the most common terms for decades in Mathematics Education research, the word "*misconception*", interpreted according to a constructive perspective proposed by D'Amore (1999: p. 124): «A misconception is a wrong concept and therefore it is an event to avoid; but it must not be seen as a totally and certainly negative situation: we cannot exclude that to reach the construction of a concept, it is *necessary* to go through a temporary misconception that is being arranged». According to this choice, misconceptions are considered as steps the students must go through, that must be controlled under a didactic point of view and that are not an obstacle for students' future learning if they are bound to *weak and unstable* images of the concept; they represent, instead, an obstacle to learning if they are rooted in *strong and stable models*. For further investigation into this interpretation, look in D'Amore, Sbaragli (2005).

To understand what a misconception is, we believe it is necessary to make clear what is a concept and a conceptualization. Taking the special epistemological and ontological nature of mathematical objects as a starting point, we will show that mathematics requires a specific cognitive functioning that coincides with a complex semiotic activity immersed in systems of historical and cultural signification. This paper highlights that handling the semiotic activity is bristling with difficulties that hinder correct conceptual acquisition.

We will follow a constructive approach to misconceptions, analyzing them within the semiotic-cognitive and semiotic-cultural frameworks, upheld by Raymond Duval and Luis Radford respectively.

Theoretical framework

D'Amore's constructive approach to misconceptions

The problem of misconceptions developed within cognitive psychology studies, aiming at understanding the formation of concepts. In what follows, we refer to D'Amore (1999), but for the sake of brevity, we will not quote him.

This kind of approach focusses on the cognitive activity of the individual who is exposed to adequate stimuli and solicitations, and adapts his cognitive structures through assimilation and accommodation processes. The cognitive structures we mentioned above are characterised by two important functions that the human mind is able to perform: images and models formation.

The main characteristics of images and models are:

- Subjectivness, i.e. a strong relationship with individual experiences and characteristics.
- Absence of a proper sensorial productive input.
- Relation to a thought, therefore it does not exist per se, as a unique entity.
- Sensory and bound to senses.

An image is *weak* and transitory and accounts for the mathematical activity the pupil is exposed to in the learning process; it undergoes changes to adapt to more complex and rich mathematical situations set by didactical engineering as a path to reach a concept C.

A model has a *dynamical* character and it is seen as a limit image of successive adaptations to richer and richer mathematical situations. We recognise the limit image when a particular image doesn't need further modifications as it encounters new and more difficult situations. We can conclude that a model is a strong and *stable* image of the concept C the teacher wants the pupil to learn. A model among the images is the definitive one which contains the maximum of information and it is stable when facing many further solicitations. When an image is formed there are two possibilities:

- The model M is the correct representation for the concept C.
- The model M is formed when the image is incomplete and it had to be further broadened. At this point it is more difficult to reach the concept C, because of the strength of M towards changes.

The adaptive process the student has to handle in his path towards the construction of a concept gives rise to a cognitive and emotional *conflict*, since he has to move to a new cognitive tool when the one he was using was working well; we usually call such conflict an error and the student requires specific support on the part of the teacher.

An image that worked well, has become inappropriate in a new situation and needs to be broadened for further use of the concept, is called a *misconception*. In the

constructive perspective we have chosen, a misconception is not seen as a negative phenomenon, as long as it is bound to weak images. As we have already said, misconceptions are necessary stages the pupil has to go through in his learning process, and they must be controlled under a didactic point of view to ensure they are bound to modifiable images, and not to stable models that would hinder the student's conceptual acquisition.

We propose a classical primary school example of this path that leads the pupil towards the conceptualisation, starting from an image and ending with a model, passing through a cognitive conflict.

A grade 1 primary school student has always seen the drawing of a rectangle "lying" on its horizontal base with its height vertical and shorter. He constructed this image of the concept "rectangle" that has always been confirmed by experience. Most textbooks propose this prototypical image:

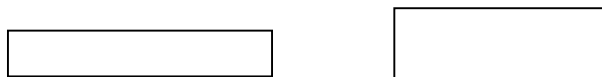

At a certain point the teacher proposes a different image of the rectangle that has the base smaller than its height.

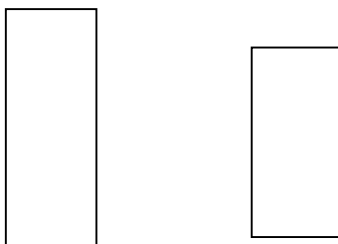

The pupil's spontaneous denomination in order to adapt the concept already assumed is extremely meaningful: he defines this new shape as "standing rectangle", opposed to the former "lying rectangle", which expresses the more inclusive character of this image.

This denomination testifies the positive outcome of a cognitive conflict between a misconception (an improper fixed image of the concept "rectangle") and the new image wisely proposed by the teacher. The student already had an image bound to his embodied sensorial activity and the teacher's new proposal, obliging the student to move to a higher level of generality of this mathematical object.

An example of a misconception bound to a model that hinders the pupil's cognitive development is of a grade 11 high school pupil dealing with second degree equations.

We propose the solution in an assessment of the following equation: $2x^2+3x+5 = 0$

The student behaves as follows: $2x^2 = -3x-5$, $x = \pm\sqrt{(-3x-5)/2}$

At this point, he is unable to go further, even with the teacher's help. We highlight that the solution of second degree equations had already been explained to the class.

In this example, we can see how the procedure for the solution of first degree equations condensed into a strong model that didn't change even after the teacher's further explanations and mathematical activities.

This example shows that a misconception is not a lack of knowledge or a wrong concept, but knowledge that doesn't work in a broader situation.

In this purely psychological perspective, the construction of concepts in mathematics is independent of the semiotic activity. Signs are used only for appropriation and communication of the concept, *after* it has been obtained by other means. In mathematics, both when dealing with the production of new knowledge and with teaching-learning processes, this position is untenable, due to the ontological and epistemological nature of its objects.

In fact, we witness a reverse phenomenon: «Of course, we can always have the “feeling” that we perform treatments at the level of mental representations without explicitly mobilising semiotic representations. This introspective illusion is related to the lack of knowledge of a fundamental cultural and genetic fact: the development of mental representations is bound to the acquisition and interiorisation of semiotic systems and representations, starting with natural language» (Duval, 1995, p. 29).

Duval's semiotic-cognitive approach

Every mathematical concept refers to “non objects” that do not belong to our concrete experience; in mathematics ostensive referrals are impossible, therefore every mathematical concept intrinsically requires to work with semiotic representations, since we cannot display “objects” that are directly accessible.

The lack of *ostensive* referrals led Duval to assign the use of representations, organized in semiotic systems, a constitutive role in mathematical thinking; from this point of view he claims that there *isn't noetics without semiotics*. «The special epistemological situation of mathematics compared to other fields of knowledge leads to bestow upon semiotic representations a fundamental role. First of all they are the only way to access mathematical objects» (Duval, 2006).

The peculiar nature of mathematical objects allows outlining a specific cognitive functioning that characterises the evolution and the learning of mathematics. The cognitive processes that underlay mathematical practice are strictly bound to a complex semiotic activity that involves the coordination of at least two semiotic systems. We can say that conceptualisation itself, in Mathematics, can be identified with this complex

coordination of several semiotic systems.

Semiotic systems are recognizable by:

- Organizing rules to combine or to assemble significant elements, for example letters, words, figural units.
- Elements that have a meaning only when opposed to or in relation with other elements (for example decimal numeration system) and by their use according to the organizing rules to designate objects (Duval, 2006).

Duval (1995a) identifies conceptualisation with the following cognitive-semiotic activities, specific for Mathematics:

- *formation* of the semiotic representation of the object, respecting the constraints of the semiotic system;
- *treatment* i.e. transformation of a representation into another representation in the same semiotic system;
- *conversion* i.e. the transformation of a representation into another representation in a new semiotic system.

The very combination of these three “actions” on a concept can be considered as the “construction of knowledge in mathematics”; but the coordination of these three actions is not spontaneous nor easily managed; this represents the cause for many difficulties in the learning of mathematics.

Duval bestows upon conversion a central role in the conceptual acquisition of mathematical objects:

«(...) registers coordination is the condition for the mastering of understanding since it is the condition for a real differentiation between mathematical objects and their representation. It is a threshold that changes the attitude towards an activity or a domain when it is overcome. (...) Now, in this coordination there is nothing spontaneous» (Duval, 1995b).

The coordination of semiotic systems, through the three cognitive activities mentioned above, broaden our cognitive possibilities because they allow transformations and operations on the mathematical object. When the object is accessible, distinguishing the representative from its representation and recognizing the common reference of several representations bound by semiotic transformations is guaranteed by the comparison between each single representation with the object. In Mathematics the situation is more complicated, because there is no object to carry out the distinction mentioned above and to guarantee the common reference of different representations to the object. The lack of ostensive referrals makes the semiotic activity problematic in terms of production, transformation and interpretation of signs.

From an educational point of view, this is a fundamental issue that leads the student to confuse the mathematical object with its representations and requires a conceptual acquisition of the object itself to govern the semiotic activity that in turn allows the development of mathematical knowledge. This self-referential situation is known as *Duval's cognitive paradox*: «(...) on one hand the learning of mathematical objects cannot be but a conceptual learning, on the other an activity on the objects is possible only through semiotic representations. This paradox can be for learning a true vicious circle. How could learners not confuse mathematical objects if they cannot have relationships but with semiotic representations? The impossibility of a direct access to mathematical objects, which can only take place through a semiotic representation leads to an *unavoidable* confusion. And, on the other hand, how can learners master mathematical procedures, necessarily bound to semiotic representations, if they do not already possess a conceptual learning of the represented objects?» (Duval, 1993, p. 38).

In the example that follows, given by Duval (2006) at the beginning of high school, we can see how the semiotic activity, in this case conversion, is crucial for the solution of the problem. Students encounter difficulties finding the solution because they are stuck on the fractional representation of rational numbers or, worse, they consider fractions and decimal representation different numbers. The mathematical procedure is grounded on the cognitive semiotic activity. The mathematics involved is very simple but the semiotic task is not trivial.

$$1 + 1/2 + 1/4 + 1/5 + \dots = 2$$

The following conversion solves the problem brilliantly, shifting from the fraction representation of rational numbers to the decimal one.

$$1 + 0.5 + 0.25 + 0.20 + \dots = 2$$

Radford's semiotic-cultural approach

Within the semiotic path we follow to understand mathematical thinking, we make a step forward and move on to Radford's semiotic-cultural framework.

Radford's theory of knowledge objectification, considers thinking a *mediated reflection* that takes place in accordance with the mode or form of *individuals' activity* (Radford, 2005):

- The *reflexive* nature refers to the relationship between the individual consciousness and a culturally constructed reality.
- The *mediated* nature refers to the means that orient thinking and allows consciousness to become aware of and understand the cultural reality; Radford calls such means *Semiotic Means of Objectification* (Radford, 2002). The word semiotic is used in a broader sense to include the whole of the individuals embodied experience that develops in terms of bodily actions, use of artifacts and symbolic activity: artifacts,

gestures, deictic and generative use of natural language, kinaesthetic activity, feelings, sensations and Duval's semiotic systems. Semiotic Means of Objectification mustn't be considered as practical and neutral technical tools, but they incarnate historically constituted knowledge. They bare the culture in which they have been developed and used. The semiotic means determine the way we interpret and understand reality that is given through our senses. The mediated nature of thinking is constitutive of our cognitive capabilities and makes thinking culturally dependent.

- *Activity* refers to the fact that mediated reflection is not considered here a solitary purely mental process, but it involves shared practices that the cultural and social environment considers relevant.

Before analyzing the learning process, we need to deal with the notion of mathematical object in Radford's objectification theory. Going beyond realist and empiristic ontologies, the theory of knowledge objectification considers mathematical objects culturally and historically generated by the mathematical activity of individuals. In agreement with the mediated reflexive nature of thinking and from the viewpoint of an anthropological epistemology Radford claims that «(...) Mathematical objects are fixed patterns of activity embedded in the always changing realm of reflective and mediated social practice» (Radford, 2004; p.21).

Learning is an objectification process that allows the pupil to become aware of the mathematical object that is culturally already there, but it is not evident to the student. Ontogenetically speaking, the student carries out a reflection on reality, not to construct and generate the object as it happens phylogenetically, but to make sense of it. Learning is therefore an *objectification* process that transforms *conceptual and cultural* objects into objects of our *consciousness*. In this meaning-making process, the semiotic means of objectification within socially shared practices allow the student's individual space-time experience to encounter the general disembodied cultural object.

The access to the object and its conceptualization is only possible within a semiotic process and it is forged out of the multifaceted dialectical interplay of various semiotic means, with their range of possibilities and limitations. This multifaceted interplay synchronically involves, within reflexive activity, bodily actions, artefacts, language and symbols. At different levels of generality these three elements are always present. For example, at the first stage of generalization in algebra students have mainly recourse to gestures and deictic use of natural language, whereas in dealing with calculus the use of formal symbolism will be predominant, nevertheless without disregarding the kinaesthetic activity or the use of artefacts.

In the objectification process the student lives a conflict between his reflexive activity situated in his personal space-time embodied experience and the disembodied meaning of the general and ideal cultural object. The teaching-learning process has to face the dichotomy between the phylogenesis of the mathematical object and the ontogenesis of the learning process. The cognitive processes phylogenetically and ontogenetically

involve the same reflexive activity, but with a significant difference: in the first case the mathematical object emerges as a fixed pattern; in the second case the object has its independent existence and the didactic engineering has to devise specific practices to allow the student becoming aware of such object.

To heal the conflict between embodied and disembodied meaning, the student has to handle more complex and advanced forms of representation «that require a kind of *rupture* with the ostensive gestures and contextually based key linguistic terms that underpin presymbolic generalizations» (Radford, 2003: p. 37).

The following example proposed by Radford (2005) shows the difficulty students encounter when they have to use algebraic symbolism that cannot directly incorporate their bodily experience. Students were asked to find the number of toothpicks for the n -th figure of the following sequence.

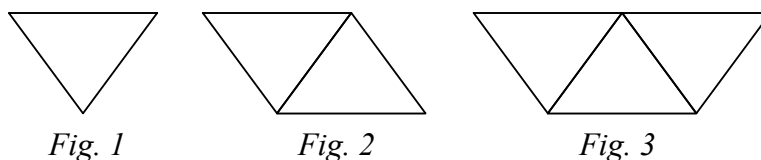

After resorting to gestures, deictic use of natural language, students manage to write the algebraic expression $n+(n+1)$ [n is the number of the figure in the sequence], but they are not ready to carry out the trivial algebraic transformation that leads to $2n+1$. The parentheses have a strong power in relating the algebraic representation to their visual and spatial designation of the figure, disregarding them implies a disembodiment of meaning that it is not easily accepted. Even though $2n+1$ is syntactically equivalent to $n+(n+1)$, the former expression requires a rupture with spatial based semiotic means of objectification and a leap to higher levels of generality.

Misconceptions: a semiotic interpretation

The semiotic approach we have outlined in the previous sections provides powerful tools to understand the nature of misconceptions. From what we said, the path that from weak images leads to strong models can be seen as the interiorisation of a complex semiotic activity; the student has acquired a correct *model* of the concept when he masters the coordination of a *set of representations*, relative to that concept, that is *stable* and effective in facing diverse mathematical situations. The student acquires control of an adequate set of representations, through an adaptation process that enlarges the representations of the set and coordinates them in terms of semiotic activity. From a semiotic point of view an *image*, is a *temporary* set of representations that needs to be developed, both in terms of representations and of their coordination, as the student faces new and more exhaustive solicitations.

A misconception is a set of representations that worked well in previous situations but it

is inappropriate in a new one. If a misconception is relative to a weak image the student is able to enlarge the set of representations and he is also ready to carry out more complex semiotic operations. In this case a misconception is a necessary and useful step the student must go through. If, instead, a misconception is related to a strong model the student will refuse to incorporate new representations and commit himself to more elaborated semiotic transformations. At this point, the pupil's cognitive functioning is stuck and he is unable to solve problems, deal with non standard mathematical situations and broaden his conceptual horizon. His reasoning is bridled in repetitive cognitive paths related to the same representations and transformations. In this case, a misconception is a negative event that must be avoided.

The representations we mentioned above are Radford's Semiotic Means of Objectification, including also Duval's semiotic systems. We can broaden D'Amore's (2003, p.55-56) *constructivist* view point of mathematical knowledge based on Duval's semiotic operations (formation, treatment and conversion) on semiotic systems, to include also bodily activity and artefacts and deal with more general Semiotic Means of Objectification. The positive outcome of the construction of a mathematical concept is therefore the dialectical interplay of Semiotic Means of Objectification that includes also treatments and conversions on semiotic systems. Such positive outcome is not a plain solitary process but it is culturally embedded in shared activity and it must overcome three synchronically entangled turning points that give rise to misconceptions; for sake of clarity we will discuss them separately but to show how entangled they are we will propose always the same example to explicit them.

- The first turning point we discuss is the *cognitive paradox*. The first and only possible approach to the mathematical object the student has is with a particular semiotic means of objectification. It can be an artefact, a drawing or a linguistic expression. He necessarily identifies the object with the first representation he encounters and connecting it with others is not spontaneous and requires a specific didactic action to go through this misconception. The student spontaneously sticks to the first representation that worked well in the situation devised by the teacher, but he is in trouble when a new situation requires to connect the first representation to a new one, because he believes that such representation *is* the mathematical object.

We can take the prototypical example of the rectangle we analyzed in section 2.1. In primary school the first access to the rectangle usually is a drawing with the base longer than the height. The student thinks that the object rectangle is *that* drawing with *those* specific perceptual characteristics. He is in trouble when the teacher proposes the new representation; he calls it "standing rectangle". If the teacher hadn't exposed the student to a new solicitation that first misconception would have condensed into a model, hindering the pupil's further cognitive development.

- The second turning point is the *coordination* of a variety of representations. In terms of Semiotic Means of Objectification the student has to handle a very complicated situation. First of all, the semiotic means can be very different from each other in terms both of their characteristics and the way they are employed. For instance a gesture is

very different from an algebraic expression. The first one is used spontaneously, while the second is submitted to strict syntactic rules. The first one is related to the kinaesthetic activity, whereas the second one is a semiotic system that does not incorporate the students' kinaesthetic experience in a direct manner. An algebraic expression requires treatment and conversion transformations, while these operations are impossible with gestures. The student has to handle a semiotic complexity that leads to misconceptions mainly related to the coordination of semiotic means. The interplay of heterogenous Semiotic Means of Objectification is not spontaneous and it requires a specific didactic action.

Let us turn back to the example of the rectangle. In his cognitive history the student will have to coordinate more and more representations of this object. We have seen that he started with a very simple drawing, perceptively effective. The teacher proposes a treatment that leads the student to consider a new representation that is in conflict with the previous one. This is not enough to construct a model of the rectangle. As the mathematical problems become more complicated he will need to resort, through conversions, to other semiotic systems like natural language, the cartesian system or the algebraic one. We can ask him if a square is a rectangle, at this point he needs to combine his perceptual experience bound to the figural semiotic system with the definition given in natural language. Many students cannot accept that a square is a rectangle. In high school we could ask him to calculate the area of a rectangle obtained by the intersection of four straight lines given as first degree equations. Although the problem is simple from a mathematical point of view, it puzzles the student because of a complex semiotic activity that involves conversions between cartesian and algebraic representations. In this case, conversion is a heavy task to accomplish because of non congruence phenomena (Duval, 2005a, pp. 55-59). The student has to face a misconception that will cause a compartmentalization of semiotic systems, hindering his semiotic degree of freedom.

The coordination of many representations is a source of misconception, also because, as recent researches in the field conducted by (D'Amore, 2006) show, semiotic transformations change the sense of mathematical objects. For the student each representation has its own meaning related to the nature of the semiotic means of objectification and to the shared practices on the object carried out through such representation. The misconception of the rectangle is a good example of this phenomenon. Students bestow different senses upon each representation, at such a point that the child calls them "lying" and "standing" rectangles, as if they were different objects. It turns out that keeping the same denotation of different representations is a cognitive objective difficult to acquire because it demands to handle many representations without accessing what is represented.

- The last turning point we want to discuss regards the *disembodiment of meaning*. We have seen that there is a dichotomy between the space-time situated embodied experience of the pupil and the disembodied general mathematical object. The student lives a conflict between the embodied and situated nature of his personal learning

experience and the disembodied general nature of the mathematical object. The mathematical cognitive activity of the child cannot start but in an embodied manner resorting mainly to Semiotic Means of Objectification related to bodily actions and the use of artefacts. But, when the mathematical activity requires a higher level of generality, the student must also engage in abstract symbols; the toothpicks shows how difficult it is for the student to give up his space situated experience, and how the algebraic language is meaningful to him as long as it describes his contextual activity. The conflict between situated experience and the generality and abstraction of the mathematical object is a source of misconceptions. At present, it is not completely clear how the disembodiment of meaning takes place. We know that the disembodiment of meaning requires the coordination of Duval's semiotic systems, in terms of treatment and conversion, and what we usually do is to expose students to an abstract symbolic activity, aware that we must handle the rise of misconceptions. Turning back to the example of the rectangle, the "lying" rectangle and the "standing" one are symptoms of the embodied meaning bound to the student's perceptual and sensorial experience. The treatment between the two figurative representations implies a disembodiment of meaning that must continue as natural language and other semiotic systems will be introduced so that the pupil can grasp the general and abstract sense of the rectangle.

We have presented a thorough analysis of misconceptions from a semiotic perspective. Anyway, it is possible to single out from what we have said a pivot upon which the issue of conceptualization and misconception turns, i.e. the lack of ostensive referrals of mathematical objects. The inaccessibility of mathematical objects both imposes the use semiotic representations and makes the semiotic activity intrinsically problematic.

A first classification of misconceptions

From what we have said above, on the one hand it seems that misconceptions are somehow a necessary element of the learning of mathematics and on the other the role of the teacher is crucial to overcome them by supporting the student's ability to handle the semiotic activity. We have, hence, divided misconceptions into two big categories: "*unavoidable*" and "*avoidable*" (Sbaragli, 2005); the first *does not depend directly on the teacher's didactic transposition*, whereas the second *depends exactly on the didactic choices and didactic engineering devised by the teacher*. Avoidable misconceptions derive directly from teachers' choices and improper habits proposed to pupils by didactic praxis. Unavoidable misconceptions derive only *indirectly from teachers choices* and are bound to the need of beginning from a starting knowledge that, in general is not exhaustive of the whole mathematical concept we want to present.

We will analyze avoidable and unavoidable misconceptions referring to the three turning points mentioned above.

“Unavoidableness”

“Unavoidable” misconceptions, that do not derive from didactical transposition and didactic engineering, depend mainly on the intrinsic unapproachableness of mathematical objects. Duval’s (1993) paradox is a source of misconceptions that gives rise to an *unavoidable* confusion between semiotic representations and the object itself, especially when the concept is proposed for the first time. Another source of unavoidable misconceptions derives from the conflict between embodied and disembodied meaning of the mathematical concept. When the student learns a new mathematical concept he cannot begin to approach it with Semiotic means of Objectification related to his practical sensory-motor intelligence. These Semiotic Means of Objectification can lead the student to consider relevant “parasitical information”, in contrast with the generality of the concept, bound to the specific representation and the perceptive and motor factors involved in his mathematical activity. The student *unavoidably* misses the generality of the mathematical object and grounds his learning only on his sensual experience.

The following example highlights an unavoidable misconception.

We know from literature (D’Amore and Sbaragli, 2005) that a typical misconception, rooted in the learning of natural numbers is that the product of two numbers is always greater than its factors. When students pass to the multiplication in Q , they do not accept that the product of two numbers can be smaller than its factors. They are stuck to the misconception that “multiplication always increases”. This is true in N and it is reinforced by the embodied meaning enhanced by the array model of multiplication perceptually very strong, effective in the first stages of students’ learning of arithmetic and in strong agreement with the idea of multiplication as a repeated sum. We can see that there is strong congruence between the figural representation and the symbolic one that makes conversion very natural.

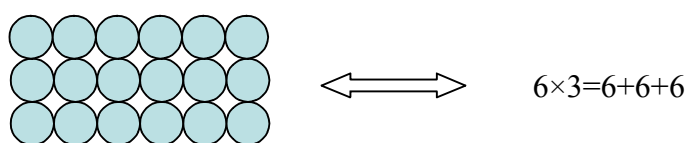

When we pass to Q and consider 6×0.2 what does it mean to sum 6, 0.2 times, and what is an array with 0.2 rows and 6 columns?

We can see how the strong identification of the mathematical object with its representation hinders the development of the concept, and it is also clear that this identification is an unavoidable passage.

This example clearly shows, on the one hand, the rupture that leads from embodied to disembodied general meaning, the student has to go through when he faces rational numbers and how difficult it is to give up the perceptual and sensory evocative power of

the array. On the other hand, it is also evident that we cannot avoid the embodied meaning skipping directly to a general and formal definition of multiplication.

The array is an effective Semiotic Means of Objectification when the student *begins* to learn multiplication in \mathbb{N} , but if there is no *specific didactic action* that fosters the generalizing process towards the mathematical concept, it condensates into a strong model, difficult to uproot. The array image of multiplication is a typical example of a parasitical model. This last remark opens the way for the discussion of avoidable misconceptions.

“Avoidableness”

Avoidable misconceptions derive directly from *didactic transposition and didactic engineering*, since they are a direct consequence of the teachers’ choices.

We have seen that the cognitive paradox and disembodiment of meaning give rise to unavoidable misconceptions. Nevertheless the teacher has an important degree of freedom to intervene in the students’ ability to handle the semiotic activity. Even if misconceptions are unavoidable they must be related to images without becoming stable models. This is possible if the student is supported in handling the complex semiotic activity, within socially shared practices, that fosters the *cognitive rupture*, allowing the pupil to incorporate his kinaesthetic experience in more complex and abstract semiotic means. The student thus goes beyond the embodied meaning of the object and endows it with its cultural interpersonal value. In this perspective, Duval (1995) offers important didactic indications to manage the rupture described above, when he highlights the importance of exposing the student, in a critical and aware manner, to many representations in different semiotic registers, overcoming also the cognitive paradox. Nevertheless didactic praxis is “undermined” by improper habits that expose pupils to univocal and inadequate semiotic representations, transforming avoidable misconceptions in strong models or giving rise to new ones.

An emblematic example of an inadequate semiotic choice that brings to improper and misleading information relative to the proposed concept, regards the habit of indicating the angle with a “little arc” between the two half-lines that determine it. Indeed, the limitedness of the “little arc” is in contrast with the boundlessness of the angle as a mathematical abstract “object”. This implies that in a research involving students of the Faculty of Education, most of the persons interviewed claimed that the angle corresponds to the length of the little arc or to the limited part of the plane that it identifies, falling into an embarrassing contradiction; two half lines starting from a common point determine infinite angles! (Sbaragli, 2005).

An inadequate didactical transposition or didactic engineering can in fact strengthen the confusion, lived by the student, between the symbolic representations and the mathematical object. The result is that «the student is unaware that he is learning signs that stand for concepts and that he should instead learn concepts; if the teacher has

never thought over this issue, he will believe that the student is learning concepts, while in fact he is only “learning” to use signs» (D’Amore, 2003; p. 43).

It thus emerges how often the choice of the representation, is not an aware didactical choice but it derives from teachers’ wrong models. And yet, in order to avoid creating strong misunderstandings it is first required that the teacher knows the “institutional” meaning of the mathematical object that she wants her students to learn, secondly she must direct the didactical methods in a critical and aware manner.

From a didactical point of view, it is therefore absolutely necessary to overcome “unavoidable” misconceptions and prevent the “avoidable” ones, with particular attention to the Semiotic Means of Objectification, providing a great variety of representations appropriately organized and integrated into a social system of meaning production, in which students experience shared mathematical practices.

From what we have said, learning turns out to be a constructive semiotic process that entangles representations and concepts in a complex network, with the rise of misconceptions. Therefore the task of the teacher is to be extremely sensible towards misconceptions that can come out during the teaching-learning process. The teacher must be aware that what the student thinks as a correct concept, it can be a misconception rooted in an improper semiotic activity.

Acknowledgments

The authors thank Prof. Gagatsis for his review of the article and for his precious corrections and suggestions.

George Santi thanks Prof. Raymond Duval and Prof. Luis Radford for the inspiring and wonderful discussions during his visits in Lille and Sudbury.

References

- D’Amore B. (1999). *Elementi di didattica della matematica*. Bologna: Pitagora.
- D’Amore B. (2003). Le basi filosofiche, pedagogiche, epistemologiche e concettuali della Didattica della Matematica. Bologna: Pitagora.
- D’Amore B. (2006). Oggetti metematici e senso. Le trasformazioni semiotiche cambiano il senso degli oggetti matematici. *La matematica e la sua didattica*. 4,557-583.
- D’Amore B., Sbaragli S. (2005). Analisi semantica e didattica dell’idea di “misconcezione”. *La matematica e la sua didattica*. 2, 139-163.
- Duval R. (1993). Registres de Représentations sémiotiques et Fonctionnement cognitif de la Pensée. *Annales de didactique et de sciences cognitives*. 5, 37-65.
- Duval R. (1995a). *Sémiosis et pensée humaine*. Ginevra: Peter Lang

- Duval R. (1995b). Quel cognitif retenir en didactique des mathématiques ? Actes de l'École d'été 1995.
- Duval R. (2006). Le trasformazioni semiotiche cambiano il senso degli oggetti matematici.. *La matematica e la sua didattica*. 4, 558-619.
- Radford L. (2002). The seen the spoken and the written: a semiotic approach to the problem of objectification of mathematical knowledge. *For the Learning of Mathematics*. 22(2), 14-23.
- Radford L. (2003). Gestures, Speech, and the Sprouting of Signs: A Semiotic-Cultural Approach to Students' Types of Generalization. *Mathematical Thinking and Learning*. 5(1), 37-70.
- Radford L. (2004) . Cose sensibili, essenze, oggetti matematici ed altre ambiguità. *La matematica e la sua didattica*. 1, 4-23.
- Radford L. (2005). La generalizzazione matematica come processo semiotico. *La matematica e la sua didattica*. 2, 191-213.
- Sbaragli S. (2005). Misconcezioni “inevitabili” e misconcezioni “evitabili”. *La matematica e la sua didattica*. 1, 57-71.



Greek students' ability in statistical problem solving: A multilevel statistical analysis

Sofia Anastasiadou

University of Western Macedonia, Greece

Abstract

In this study, Greek students' ability in statistical problem solving related to the concept of average was investigated. Three different kinds of tasks in a test for sixth grade were given to Greek students. Principal Components Analysis and Implicative Statistical Analysis were used for the analysis of the data. Both statistical analyses suggest the same grouping of students' responses and confirm the absence of high cognitive competence in statistical problem solving and flexibility related to translation of different representation modes of statistical notions.

Introduction

Nowadays probability and statistics are part of mathematics curricula for primary and secondary schools in many countries. The reasons for this development are related to the usefulness of statistics for daily life (Chadjipadelis, 2003), its instrumental role in other disciplines, the need for basic stochastic knowledge in many professions, and its key role in developing critical reasoning (Batanero et al., 2004).

Understanding of statistical concepts does not appear to be easy, given the diversity of representations associated to this concept, and the difficulties inherent in the processes of articulating systems of representation involved in probabilistic and statistical problem solving (SPS) (Anastasiadou, 2007). Statistical notions are difficult to teach for various reasons, including disparity between intuition and conceptual development even regarding apparent elementary concepts (Chadjipadelis & Gastaris, 1995).

The need for a variety of semiotic representations in the teaching and learning of probability is usually explained through reference to the cost of processing, the limited representation affordances for each domain of symbolism and the ability to transfer knowledge from one representation to another (Duval, 1987; Gagatsis, Elia, I. & Mougi, 2002; Gagatsis, & Elia, 2004). A representation is any configuration (of characters, images, concrete objects, etc.), that can denote, symbolize, or otherwise "represent" something else (Palmer, 1978; DeWindt-King & Goldin, 2003; Goldin, 1998; Kaput, 1985). DeWindt-King & Goldin (2003) mentioned that according to Goldin & Kaput (1996) and Vergnaud (1998) such representing relationships are often two-way, so that

the depiction or symbolization can be interpreted in either direction, In the last decades, great attention has been devoted to the concept of representation and its role in the learning of mathematics (Gagatsis, & Elia, 2004; 2005; Gagatsis, Elia, I. & Mougi, 2002; Elia, & Gagatsis, 2006). A basic reason for this emphasis is that representations are considered as an “integral” part of mathematics (Kaput, 1987). In certain cases, specific representations are so closely connected to a mathematical concept that it is difficult for the concept to be understood and acquired without the use of these representations. Students experience a wide range of representations from their early childhood years. A main reason for this is that most mathematics textbooks today use a variety of representations in order to enhance understanding. Greeno & Hall (1997) maintain that representations may be considered useful tools for constructing understanding and for communicating information. They underline how it is important to engage students in activities like choose or construct representations in such forms that help them to see patterns and perform calculations, taking advantage of the fact that different forms provide different support for inference and calculation. Similarly, Kalathil & Sheril (2000) describe ways in which representations may be useful in providing information on how students think about a mathematical issue, and serve as classroom tool for the students and the teacher. In mathematics instruction representations get a crucial role as teachers can improve conceptual learning if they use or invent effective representations (Cheng, 2000).

The use of multiple representations, such as pictures and text combined, is a main feature of mathematics education, which deals with a wide range of representations of ideas in order to enhance understanding. Generally, there is strong support in the mathematics education community that students can grasp the meaning of mathematical concepts by experiencing multiple mathematical representations (Lesh, Post, & Behr 1987; Sierpinska, 1992). Principles and standards for school mathematics (NCTM, 2000) include a standard referring exclusively to representations and emphasize their value for understanding. Learning from verbal and pictorial information has generally been considered beneficial for learning (Carney & Levin, 2002; Schnotz, 2002). For example, Ainsworth, Wood, & Bibby (1997) suggest that the use of multiple representations may help students develop different ideas and processes, constrain meanings, and promote deeper understanding. Furthermore, a second representation may be provided to support the interpretation of a more complicated or less familiar representation (Gagatsis & Michaelidou, 2002).

Students may have very different representations and, as Kendal and Stacey (2000) stated, representations which are emphasized in the teaching influence on the construction of students’ internal representations. According to Goldin (1998) representation systems are proposed to develop through three stages, so that first, new signs are taken to symbolize aspects of a previously established system of representation. Then the structure of the new representation system develops in the old system and finally the new system becomes autonomous.

Janvier introduced the notion of “translation” between two different representations. By a translation process, we denominate the psychological processes involved when

moving from one mode of representation to another (Janvier, 1987). Janvier (1987) mentioned that translation is an activity, one where the naive interpretation is of 'preservation of meaning', but anyone who has seriously attempted to translate a text will be aware of needing to work simultaneously on the three major components of language: the forms, the functions and the meanings. Similarly, changing representation requires attention to all three of these aspects.

Several researchers in the last two decades addressed the critical problem of translation between and within representations, and emphasized the importance of moving among multiple representations and connecting them (Elia & Gagatsis 2006; Gagatsis, & Elia, 2004; Hitt, 1998; Yerushalmy, 1997). Duval (2002) mentioned that there is a key distinction for analysing mathematical activity from a learning and teaching perspective rather than a perspective of mathematical research by mathematicians. There are two types of transformation of semiotic representations which are radically different: treatments and conversions. Treatments are transformations of representations which happen within the same register. Conversions are transformations of representation which consist of changing a register without changing the objects being denoted (Duval 2002). According to Elia & Gagatsis (2006), the role of representations is a central issue in the teaching of mathematics. The most important aspect of this issue refers to the diversity of representations for the same concept, the connection between them and the conversion from one mode of representation to others. Gagatsis & Shiakalli (2004) and Ainsworth (2006) suggest that different representations of the same concept complement each other and contribute to a more global and deeper understanding of it.

Understanding a mathematical concept presupposes the ability to recognise this concept when it is presented by a series of qualitatively different representation systems (registers), the ability to flexibly handle this concept in the specific representation systems, and finally, the ability to translate the concept from one system to another (Dufur-Janvier, Bednarz & Belanger, 1987; Lesh, Post, & Behr, 1987). Duval (2002) suggested that it is the decompartmentalization of registers which constitutes one of the conditions for access to mathematical comprehension and not vice versa. As Gray and Tall (2001) underline it's very important to connect perceptual representations to symbolic representations.

There are four main ideas in order to conceptualise representation. Firstly, within the domain of mathematics, representation may be a thought of internal- abstraction of mathematical ideas or cognitive schemata that are developed by the learner through experience (Pape & Tchoshanov, 2001). Secondly, representation can be explicated as "mental reproduction of a former mental state". Thirdly, "a structurally equivalent presentation through pictures, symbols and signs" (also means to representation). Finally, it is also known as "something in place of something" (Seeger, 1998).

Recent research tried to examine the role of representations in Statistics learning, teaching and instruction.

Anastasiadou and Gagatsis (2007) tried to identify students' abilities to handle various representations, and to translate among representations related to the same statistical

relationship across three age levels in primary education. Their findings provide a strong case for the role of different modes of representation on students' performance to tasks on basic statistical concepts such as frequency. At the same time, these findings enable a developmental interpretation of students' difficulties in relation to representations of frequency. Students' success was found to increase with age. But despite the improvement of students' performance from third to fifth grade, students in both grades encountered difficulties in the understanding of statistical concepts and more specifically in moving flexibly from one representation to another. Sixth grade students' success was found to be independent of the initial or the target representation of the tasks. Their high and consistent outcomes in all of the conversion tasks indicate that they have developed the understanding of the relations among representations and the skills of representing and handling flexibly basic statistical knowledge in various forms. The above findings are in line with the results of a similar study of Anastasiadou, Elia and Gagatsis (2007).

The main objective of Anastasiadou (2008) study was to contribute to the understanding of the role of different types of representations and translations in statistical problem solving (SPS) when the concept of average is involved in Greek primary school. Specifically, this study investigates the abilities of 3rd, 5th and 6th grade primary school indigenous students and immigrants in using representations of basic statistical concepts and in moving from one representation to another. The results of this study reveal that indigenous students have not acquired sufficient abilities for transformation from one representation system to another. Results reveal the differential effects of each form of representation on two groups of students' performance and the improvement of performance with age of indigenous students.

This study analyzes the role of different modes of representation on understanding of some basic probabilistic concepts. Teachers' performance is investigated in two aspects of probabilistic understanding: the flexibility in using multiple representations and the ability to solve the problems posed.

Tasks

The test included 12 tasks covering the concepts of average, its estimation, and its relation to bar charts, diagrams and predictions, and more generally, its application to solving everyday problems. Students' responses to the tasks comprise the variables of the study which are codified by an uppercase letter followed by the number of the item and two letters. The uppercase letters denote the concept involved in the task; V stands for tasks, the number followed stands for the exercise number. The lower case letters following denote the type of representation: b = bar chart, g = graphic/ diagram, v = verbal, a= average. Correct answers are encoded as 1, wrong or no answers as 0, and partial solutions are encoded as 0.5. For example, V2ba and V3ga tasks are the following:

V2ba: in the diagram (bar chart) below the financial profits of a supermarket during a week. Which is the average of financial profits of the supermarket daily?

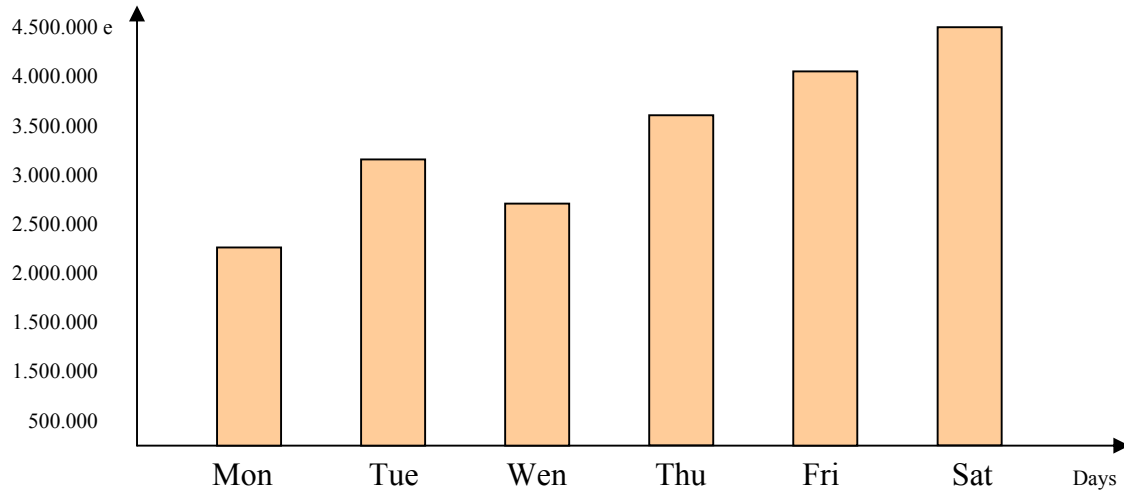

V3ga: I observe and write down the temperature development during the day of Friday.

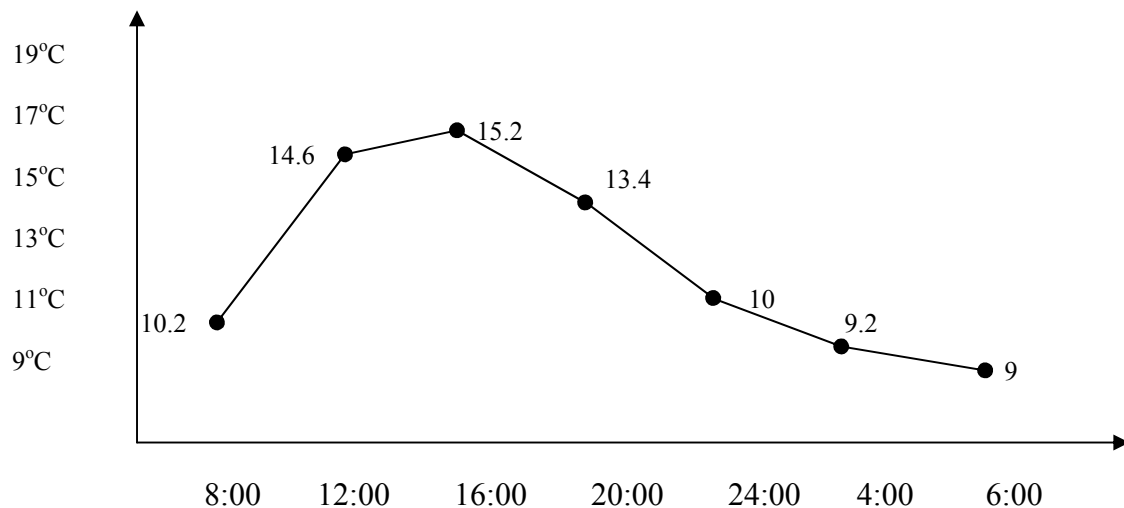

Find the average of the temperature of the day of Friday. Put up it in the diagram with a red pencil.

Participants – Research methodology

The sample was 120 sixth grade Greek primary school students from the region of Western Macedonia. For the analysis of the collected data we use a multilevel statistical analysis, a combination of two statistical methods, Principal Components Analysis and statistical implicative analysis.

Principal Components Analysis: Principal Components Analysis was applied in order to test the structure or construction of the proposed test. Axes rotation was carried out by using the Varimax method. This means that the factors (components) that were

extracted are linearly uncorrelated. The criterion of the eigenvalue or characteristic root (Eigenvalue) ≥ 1 was used to determine the number of factors that were maintained.

The following measures of sampling adequacy were used: a) Kaiser-Meyer-Olkin (KMO), and b) Bartlett's test of sphericity which tests whether the correlation matrix of the variables participating in the analysis presents significant differences, in terms of statistics, compared to the unit matrix, and therefore data analysis would be useful.

In order to determine whether the construction of the measurement tool actually follows the theoretical model, three criteria are taken into consideration: Questions with high factor loadings are taken into consideration upon the construction and interpretation of axes. Questions with factor loadings over 0.30 are used and taken into consideration upon the construction and interpretation of axes. Questions with high factor loadings on two factors are excluded.

Implicative Statistical Analysis: The research data analysis was based on Gras's (Gras et al., 1997) and Lerman's (1981) implicative analysis, which enables the distribution and classification of variables as well as the implicative identification among variables or variable categories. The resulting relations are not cause relations, but a quality indicator, which advocates that the answer to a question entails the answer to another question related to the first one.

The similarity was adopted from Gras's implicative analysis. In the similarity tree, the questions (V1va, V2va, V3va, V4va, V1ba, V2ba, V3ga, V4ga, V1ap, V2ap, V3ap, and V4ap) that were employed in the research are grouped according to the subjects' answer similarity. The implicative statistics data analysis was made by employing CHIC software (Classification Hierarchique Implicative et Cohesive) (Bodin, 2000).

The results of the research

The $KMO=0.825 > 0.60$ measure of sampling adequacy showed that the sample data were adequate in order to undergo factor analysis and Bartlett's test of sphericity ($sign < 0.01$) also showed that principal components analysis is useful.

Based on the analysis (Table 1), 3 uncorrelated factors occurred, which explain 78.94% of the total data inactivity, and which are described separately further on. Lastly, the values of common factor variance (Communality) for each question shows that most have a value greater than 0.50, a fact that indicates the satisfactory quality of measurements by the component model – three-factor model.

More specifically, based on student attitudes as presented by the factor analysis, variables V1va, V2va, V3va and V4va load mainly on the first axis-factor F1, which explains, following Varimax rotation, 38.92% of the total dispersion. Factor F1 represents the tasks-variables related to the verbal form of the problem data, in which the average was asked to be measured. This factor highlights the students' way of handling verbal problems in a discrete way.

Greek students' ability in statistical problem solving

Tasks V1ba, V2ba, V3ga and V4ga load on the second factor (F2), which explains 21.43% of the total dispersion. The second factor consists of the tasks related to graphical form of the problem data, in which the average was asked to be estimated.

Table1: Principal Components Analysis' Results

Tasks-Variables	Factors			Communality
	F1	F2	F3	
V1va	0.762			0.712
V2va	0.731			0.698
V3va	0.711			0.613
V4va	0.676			0.569
V1ba		0.745		0.704
V2ba		0.716		0.687
V3ga		0.683		0.654
V4ga		0.657		0.572
V1ap			0.687	0.623
V2ap			0.658	0.593
V3ap			0.532	0.518
V4ap			0.508	0.534
Eigenvalue	3.345	2.657	1.503	
Variance Explained %	38.92%	21.43%	18.59%	
Total Variance Explained %	78.94%			
Mean score per Factor	8.65	7.91	6.36	
Standard Deviation per Factor	4.546	3.183	4.167	
Kaiser-Meyer-Olkin Measure of Sampling Adequacy = 0.825 Bartlett's Test of Sphericity: $\chi^2=1231.342$, $p=0.000$				

It must be noted that none of the tasks of the test have factor loading on any other factor except of the one mentioned above, and therefore the factors are not interrelated. This suggests that the tasks-variables related to verbal form of the problem data, in which the average was asked to be measured, affected students in such way that they treated the task differently compared to the tasks.

The fourth factor (F3), which explains 18.59% of the total data inactivity, is constructed and interpreted by tasks V1ap, V2ap, V3ap, and V4ap. The third factor consists of variables that concern predictions given the average of the data.

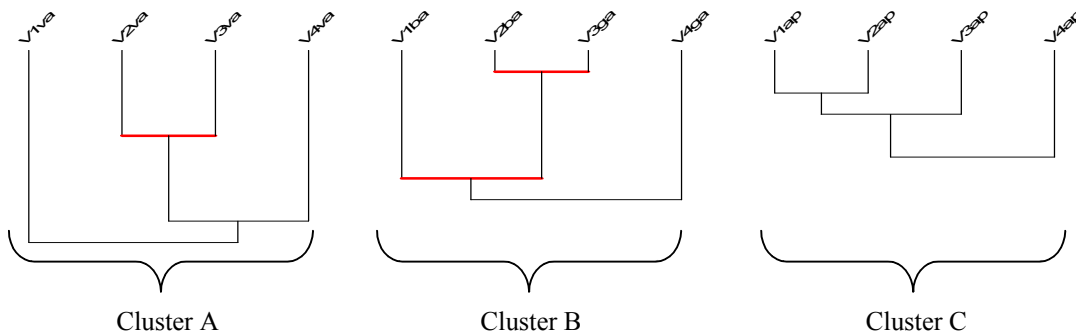

Figure 1: Similarity tree

Figure 1 illustrates the similarity diagram of the test. Students' responses to the tasks (V1va, V2va, V3va, V4va, V1ba, V2ba, V3ga, V4ga, V1ap, V2ap, V3ap, and V4ap) are responsible for the formation of three clusters (i.e. groups of variables) of similarity. The similarities in bright red have a significance level of 99%.

The first group (Cluster A) consists of tasks V1va, V2va, V3va, V4va, which represent students' efficiency in solving the problem tasks, specifically in estimating the average value and using verbal representations. The strongest similarity occurs between variables V2va and V3va (Almost 1) in the first Cluster. It is suggested that students employed similar processes to construct a problem solving strategy estimating the average value by calculating the given data.

The second similarity group (Cluster B) consists of tasks V1ba, V2ba, V3ga, V4ga, and it suggests that students employed similar processes to estimate the average of a data set represented in a bar chart or another kind of graph. The strongest similarity occurs between variables V2ba and V3ga (0.87) in the second Cluster that verifies the above assertion. The similarity connection of those variables to the variables V1ba and V4Pga reveals students' consistency with regard to their performance in evaluating the concept of average by drawing information from the graph, interpreting it algebraically and making computations.

Lastly, the following similarity group (Cluster C) is made up of tasks V1ap, V2ap, V3ap, and V4ap. The similarity connection of those reveals students' consistency with regard to their performance in evaluating the meaning of average and making significant predictions.

The similarity Cluster A is disconnected from the other similarity clusters, Cluster B and Cluster C, demonstrating students' compartmentalized ways of handling average and recognizing this concept when it is presented by a series of qualitatively different representation systems. The absence of students' flexibility that means the inability of concept recognition in various representations systems and its translation from one system to another is an indicator of students' cognitive incompetence. This conclusion

was resulted with the application both of the analysis to principal components and through implicative statistical analysis.

Conclusions

The multidimensional analysis of the preset study reveals that the results of both statistical analyses used, Principal components analysis and Implicative statistical analysis, are in line. Both methods indicate that sixth grade students' performance on average tasks that it was differentiating, depending on where the task gave the data in verbal form, or in graphic form of predictions base on the average value was asked to be made. At the same time, the findings enable a developmental interpretation of students' difficulties in relation to predictions establishment based on average. Lack of connections among different modes of representations in the similarity diagram indicates the difficulty in handling two or more representations of the same concept. Statistics instruction needs to engage students in activities including translations between different modes of representation. As a result, students will be able to overcome the compartmentalization difficulties and develop flexibility in understanding and using the most basic concept of average and others within various contexts or modes of representation and in moving from one mode of representation to another. It seems that there is a need for further investigation into the subject with the inclusion of a more extended qualitative and quantitative analysis. In the future, it would be interesting to compare strategies and modes of representations students use in order to solve the problems. Besides, longitudinal investigations might reveal new insights on how the flexibility in using the multiple representations grows.

References

- Ainsworth, S.: 2006, DeFT: A conceptual framework for considering learning with multiple representations. *Learning and Instruction* 16, 183–198.
- Ainsworth, S.E., Wood, D.J., & Bibby, P.A.: 1997, Evaluating Principles for Multi-Representational Learning Environments. Paper presented at the 7th EARLI Conference. Athens.
- Anastasiadou, S.: 2008, The effects of representational systems on the learning of statistics between Greek primary school students and immigrants Proceeding of the 5th International Mathematics Education and Society Conference (MES 5) Albufeira, Portugal, pp167-176.
- Anastasiadou, S.: 2007, The phenomenon of compartmentalization in students' processing of statistical concepts. *International Symposium Elementary Mathematics Teaching SEMT 06 Prague*, 61–68.
- Anastasiadou S., Elia I., Gagatsis A. 2007. Le rôle des représentations dans l'apprentissage des concepts de statistique des étudiants de l'école primaire de Grèce. In Regis Gras, Pilar Orus, Bruno Pinaud, Pablo Gregori Eds, 4nd International Conference Implicative Statistic Analysis, Castellon, Spain, 135-144.

- Anastasiadou, S., Gagatsis A.: 2007. A review of the effects of representation in statistics problem solving in Greek primary school. In the Fifth Conference of the European Society for Research in Mathematics Education (CERME 5), Nikosia, Cyprus, 90-100.
- Batanero C., Codino D. J., Roa R.: 2004, Training teachers to teach probabilities. *Journal of Statistics Education*, vol 12(1). Online <http://www.amstat.org/publications/jse/v12n1/batanero.html> .
- Bodin, A., Coutourier, R. & Gras, R. : 2000, CHIC : Classification Hierarchique Implicative et Cohésitive-Version sous Windows – CHIC 1.2, Association pour le Recherche en Didactique des Mathematiques, Rennes.
- Carney, R. N. & Levin, J. R.: 2002. Pictorial illustrations still improve students' learning from text. *Educational Psychology Review* 14(1), 101–120.
- Chadjipadelis T.: 2003. Data, methods and results. *Proc. 16th Panhellenic Conference on Statistics*, Kavala, 37–44
- Chadjipadelis, T. & Gastaris, P.: 1995, Difficulties of understanding and misconceptions in Probabilities and in Statistics. *Euclides C'* 43, 35–68.
- Cheng, P.C.H.: 2000, Unlocking conceptual learning in mathematics and science with effective representational systems. *Computers and Education* 33, 109–130.
- DeWindt-King, A. M. & Goldin, G. A.: 2003, Children's visual imagery: Aspects of cognitive representation in solving problems with fractions. *Mediterranean Journal for Research in Mathematics Education* 2(1), 1–42.
- Dufur-Janvier, B., Bednarz, N., & Belanger, M.: 1987, Pedagogical Considerations Concerning the Problem of representation. In Janvier, C. (Ed.), *Problem of Representation in the Teaching and Learning of Mathematics*, Lawrence Erlbaum, Hillsdale, NJ, 57–63.
- Duval, R.: 1987. The role of interpretation in learning mathematics. *Dimension*, 2, 56–74.
- Duval, R.: 2002. The cognitive analysis of problems of comprehension in the learning of mathematics. *Mediterranean Journal for Research in Mathematics Education* 1(2), 1–16.
- Gagatsis, A. and Elia, I. 2004. 'The effects of different modes of representations on mathematical problem solving', in M. Johnsen Hoines and A. Berit Fuglestad (eds.), *Proceedings of the 28th Conference of the International Group for the Psychology of Mathematics Education*, Vol. 2, Bergen University College, Bergen, Norway, pp. 447-454.
- Gagatsis, A., and Elia, I. 2005. A review of some recent studies on the role of representations in mathematics education in Cyprus and Greece. In M. Bosch (Ed.), *Proceedings of the Fourth Congress of the European Society for Research in Mathematics Education: Working Group 1, The role of metaphors and images in the*

- learning and understanding of mathematics (pp. 102-111). Saint Feliu de Guixols, Spain: ERME, <http://ermeweb.free.fr/CERME4/>.
- Gagatsis, A., Elia, I. and Mougi, A. 2002. 'Multiple Representations in Developing Mathematical Relationships', *Scientia Paedagogica Experimentalis XXXIX* (1), 9–24.
- Elia, I. and Gagatsis, A. 2006. 'The effects of different modes of representation on problem solving: Two experimental programs', in J. Novotná, H. Moraová, M. Krátká and N. Stehlíková (eds.), *Proceedings of the 30th Conference of the International Group for the Psychology of Mathematics Education, Vol. 3*, Prague, Czech Republic, pp. 3-25.
- Gagatsis, A., and Michaelidou, E. 2002. Le relazioni tra le diverse rappresentazioni del concetto di funzione e la comprensione del concetto stesso. Una ricerca riferita a gli studenti della scuola secondaria superiore. *La matematica e la sua didattica*, 4, 411-429.
- Gagatsis, A. and Shiakalli, M. 2004. 'Ability to translate from one representation of the concept of function to another and mathematical problem solving', *Educational Psychology* 24(5), 645-657.
- Goldin, G.A. 1998. Representational systems, learning, and problem solving in mathematics. *Journal of Mathematical Behavior*, 17(2), 137-165.
- Gras, R., Peter, P., Briand, H., Philippé, J. (1997). Implicative Statistical Analysis. In C. Hayashi, N. Ohsumi, N. Yajima, Y. Tanaka, H. Bock, Y. Baba (Eds.). *Proceedings of the 5th Conference of the International Federation of Classification Societies* (Volume 2, pp. 412-419). Tokyo, Berlin, Heidelberg, New York: Springer-Verlag.
- Gray, E. & Tall, D. 2001. Relationships between embodied objects and symbolic procepts: an explanatory theory of success and failure in mathematics. In Heuvel-Panhuizen, M. (Ed.) *Proceedings of the 25th conference of the international group for the psychology of mathematics education, Utrecht, 2001*, Vol.3, 65-72.
- Greeno, J. G., & Hall, R.P. 1997. Practicing representation: Learning with and about representational forms, *Phi Delta Kappan*, 78, 361-367.
- Hitt, F. 1998. 'Difficulties in the articulation of different representations linked to the concept of function', *Journal of Mathematical Behavior* 17(1), 123-134.
- Janvier, C.: 1987. 'Representation and understanding: The notion of functions as an example', in C. Janvier (ed.), *Problems of representation in the teaching and learning of mathematics*, Lawrence Erlbaum Associates, Hillsdale, N.J., pp. 67-72.
- Kalathil, R. R., and Sheril, M. G. 2000. Role of students' representations in the mathematics classroom. In B. Fishman, & S. O'Connor-Divelbiss (Eds.), *Fourth International Conference of the Learning of Sciences*, pp. 27-28. Mahwah, NJ: Erlbaum.

- Kaput, J. 1987. Representation and problem solving: methodological issues related to modelling. In E.A. Silver (Ed.), *Teaching and Learning Mathematical Problem Solving: Multiple Research Perspectives* (pp. 381-398). Hillsdale, NJ: Erlbaum.
- Kendal, M. & Stacey, K. (2000.) Acquiring the concept of the derivative: Teaching and learning with multiple representations and CAS. In Nakahara, T. & Koyama, M. (Ed.) *Proceedings of the 24th conference of the international group for the psychology of mathematics education, Hiroshima, 2000*, Vol. 3, 127-134.
- Lesh, R., Post, T. and Behr, M.: 1987. 'Representations and translation among representations in mathematics learning and problem solving', in C. Janvier (ed.), *Problems of Representation in the Teaching and Learning of Mathematics*, Lawrence Erlbaum, Hillsdale, NJ, pp. 33-40.
- Lerman, I. C.: 1981. 'Classification et analyse ordinale des données', Dunod, Paris.
- NCTM.: 2000. '*Principles and standards for school mathematics*', NCTM, Reston, Va.
- Palmer, S.E 1978. Fundamental aspects of cognitive representation. In E. Rosch and B. Lloyd (Eds.), *Cognition and Categorization*. Hillsdale, NJ: Erlbaum, pp. 259-303.
- Pape, S. J., & Tchoshanov, M. A. (2001). The role of representation(s) in developing mathematical understanding. *Theory into Practice*, 40(2), 118-125.
- Schnotz, W. 2002. towards an integrated view of learning from text and visual displays. *Educational Psychology Review*, 14(1), 101-120.
- Seeger, F. (1998). Discourse and beyond: on the ethnography of classroom discourse. In A. Sierpiska (Ed.), *Language and communication in the mathematics Classroom*. Reston: National Council of Teachers of Mathematics.
- Sierpiska, A. 1992. On understanding the notion of function. In E. Dubinsky & G. Harel (Eds.), *The concept of function: Aspects of epistemology and pedagogy* (pp. 25-28). United States: The Mathematical Association of America.
- Vergnaud, G (1998). A comprehensive theory of representation theory for mathematics education. *Journal of Mathematical Behavior* 17(2), 167-181.
- Yerushalmy, M. 1997. 'Designing representations: Reasoning about functions of two variables', *Journal for Research in Mathematics Education* 27(4), 431-466.



Fractions, decimal numbers and their representations: A research in 5th and 6th grade of elementary school

Anna Menelaou, Athanasios Gagatsis & Sergios Sergiou

Department of Education, University of Cyprus

Abstract

The present study investigates the ability of primary school pupils to use external representations and move flexibly from one system of representation to another in the context of fractions and decimals. The understanding of fractions and decimals does not appear to be easy, given the diversity of representations associated with these concepts. Streefland (1991, p. 6) suggests that fractions and decimals "are without doubt the most problematic area in mathematics education".

Introduction

Fractions and rational numbers are considered the most complex mathematical domains in school mathematics (Mack, 1990). The above concepts admit a variety of representations and consequently have the capability of being taught using diverse representations, each of which offers information about particular aspects of the concepts without being able to describe them completely. The use of multiple representations (Kaput, 1992) and the conversions from one mode of representation to another have been strongly connected with the complex process of learning in mathematics, and more particularly, with the seeking of students' better understanding of important mathematical concepts (Duval, 2002; Romberg, Fennema, & Carpenter, 1993). Some researchers interpret students' errors as either a product of a deficient handling of representations or a lack of coordination between representations (Duval, 2002; Greeno & Hall, 1997).

The role of representations in mathematical understanding and learning is a central issue of the teaching of mathematics. The most important aspect of this issue refers to the diversity of representations for the same mathematical object, the connection between them and the conversion from one mode of representation to others. This is because unlike other scientific domains, a construct in mathematics is accessible only through its semiotic representations and, in addition, one semiotic representation by itself cannot lead to the understanding of the mathematical object it represents (Duval, 2002).

In mathematics teaching and problem solving, five types of external systems of representations are used: Texts, concrete representations/models, icons or diagrams, languages and written symbols. These external representations are associated with

internal representations (Lesh et al., 1987; Duval, 1987; Kaput, 1987; Janvier, 1987; Even, 1998; Hitt, 1998; Gagatsis et al., 2001). By a translation process, we mean the psychological process involving the movement from one representation to another (Janvier, 1987). Mathematics teaching, school textbooks and other teaching materials in mathematics submit children to a wide variety of representations. The representational systems are fundamental for conceptual learning and determine, to a significant extent, what is learnt (Cheng, 2000). Understanding an idea entails: (a) the ability to recognize an idea, which is embedded in a variety of qualitatively different representational systems; (b) the ability to flexibly manipulate the idea within given representational systems and (c) the ability to translate the idea from one system to another accurately (Gagatsis & Shiakalli, 2004). This is due to the fact that a construct in mathematics is accessible only through its semiotic representations and, in addition, one semiotic representation by itself cannot lead to the understanding of the mathematical object it represents (Duval, 2002). Understanding any concept entails the ability to coherently recognize at least two different representations of the concept and the ability to pass from the one to the other without falling into contradictions (Duval, 2002; Gagatsis, & Shiakalli, 2004; Griffin, & Case, 1997).

Kaput (1992) found that translation disabilities are significant factors influencing mathematical learning. Strengthening or remediating these abilities facilitates the acquisition and use of elementary mathematical ideas. To diagnose a student's learning difficulties or to identify instructional opportunities teachers can generate a variety of useful kinds of questions by presenting an idea in one representational mode and asking the student to illustrate, describe or represent the same idea in another mode. An important educational objective in mathematics is for pupils to identify and use efficiently various forms of representation of the same mathematical concept and move flexibly from one system of representation of the concept to another (Hitt, 1998; Janvier, 1987). Despite this fact, many studies have shown that students face difficulties in transferring information gained in one context to another (e.g. Gagatsis, Shiakalli, & Panaoura, 2003; Yang, & Huang, 2004). In the last two decades, several researchers have addressed the critical problem of translation between and within representations, and emphasized the importance of moving among multiple representations and connecting them (Goldin, 1998). Researchers have also found that the translations among representations are important for students' learning (Lesh, Post & Behr, 1987), since each representation yields its own insights into mathematical concepts (Confrey & Smith, 1991). Yerushalmy (1997) showed that most students do not take into consideration the transition from one type of representation to another and thus are unable to generalize the concept. In some cases, students identify a mathematical concept with its representations but do not seem to abstract the concept from them (Vinner & Dreyfus, 1989).

In the present study we examined 5th and 6th grade students' ability to recognize fractions and decimal numbers in different representation systems, their ability to flexibly manipulate these concepts within a representational system and their ability to translate from one system of representation to another. More specifically, the research

questions were the following:

- a) Is there a compartmentalization of the tasks based on the cognitive subject that is being examined: recognition, flexible manipulation and translation of fractions and decimal numbers? b) Are the 5th and 6th grade students encountering difficulties in solving verbal problems of translation from one form of rational number to another? c) Does age (5th or 6th grade) influence the degree and type of response to representation systems? and d) Where are the 5th and 6th grade students more successful: in fractions or in decimal numbers?

Method

The participants were 105 students of the 5th grade and 105 students of the 6th grade from schools in the city of Pafos, during the 2006-2007 school year.

Four tests were administrated to all the participants (Test A, B, C and D). In test A the students were asked to recognize fractional and decimal numbers that were presented in a variety of different representations. Test A had a multiple choice format and included four recognition exercises, two exercises of recognizing fractional numbers and two exercises of recognizing decimal numbers. In exercise one, a fraction that was smaller than 1 was presented, while in exercise two, the fraction was larger than 1. The same was applied on exercises three and four for decimal numbers.

Choose the write answer in each column (A, B, C)

$\frac{3}{4}$		
A	B	C
α) $\frac{6}{8}$ β) $\frac{6}{12}$	α) 0, 75 β) 3, 4	

Test B aimed to examine students’ ability to flexibly manipulate fractions and decimal numbers through a representational system. The test was consisted of four equations: two additions of dissimilar fractions, in the first of which the denominators are multiple numbers while in the second they aren’t, and two additions of decimal numbers.

$$\frac{1}{2} + \frac{1}{6} = \quad \frac{2}{3} + \frac{1}{4} = \quad 0,8 + 0,1 = \quad 1,1 + 0,9 =$$

Test C included exercises dealing with translation from one representation system to another (symbolic, diagrammatic, and verbal representation). The first three exercises involved fractional numbers and the other three decimal numbers. In the first exercise, the students were given a symbolic representation and they were asked to translate it to its diagrammatic and verbal expression. In the second exercise the students were asked to present the symbolic and verbal representations where the source was presented in diagrammatic form. In the third exercise the verbal form was given and the students

were asked to translate it to its diagrammatic and symbolic expressions. The decimal number exercises were presented in the same form and order as the exercises involving fractions. All these exercises were equivalent and isomorphic, which means that the degree of difficulty in the corresponding exercises of each part was the same.

Symbolic form	diagrammatic form	verbal form
$\frac{1}{2} + \frac{1}{6} =$		

The collection of quantitative data was completed with Test D. Test D included two word problems which involved conversion from decimal to fractional numbers and vice versa. The purpose of this test was to examine whether the students were capable of performing conversions from decimal to fractional numbers and vice versa, through problem-solving situations.

e.g. Miss Maria, works in a bakery. She bought 10Kg flavor. She used $4\frac{2}{5}$ Kg flavor for the cakes and 4,4 Kg for biscuits. In which case she used more flavor?

For the analysis of the collected data the similarity statistical method was conducted using a computer software called C.H.I.C. (Classification Hiérarchique, Implicative et Cohésitive). A similarity diagram and an implicative diagram of students' responses at each task or problem of the four tests were constructed. The similarity diagram, which is analogous to the results of the more common method of cluster analysis, allows the arrangement of the tasks into groups according to the homogeneity by which they were handled by the students. This aggregation may be indebted to the conceptual character of every group of variables. The implicative diagram, which is derived by the application of Gras's statistical implicative method, contains implicative relations that indicate whether success to a specific task implies success to another task related to the former one. The statistical program SPSS was also used.

Variables of the study

The first letter, which is capitalized, represents the type of exercise. The recognition exercises are labeled with an R (Test A), the treatment exercises are labeled with an O (Test B), the translation exercises are labeled with an M (Test C) and the verbal exercises are labeled with a P (Test D). For Test A, the second letter, which is in lower case, shows whether it is a fraction (f) or a decimal number (d). The third letter represents the type of recognition (d-decimal number, f-fraction and p-diagram). In those cases where the number is larger than 1, the letter u is used. The number of the exercise is added to the end. For example, Rfdu2 refers to a recognition exercise (R) of a fraction (f) which will be translated to a decimal number (d) which is larger than 1 in exercise 2. In Test C the capital letters D, S, L refer to the type of initial representation, while the lower case letters d, s, l refer to the final-target representation. The fourth letter, which is also in lower case, shows whether the exercise is about fractional (f) or decimal (d) numbers. For example MDsf2 refers to an exercise of translation (M), to a

symbolic representation starting from a diagram (Ds), second exercise with the addition of dissimilar fractions (f2).

Results

The similarity diagram allows for the grouping of students' responses at the tasks based on their homogeneity. This means that the subjects succeed or fail in their grouped exercises together.

In diagram 1 four similarity groups are formed for the 5th grade. The first group consists of two subgroups and includes exercises Rff1, MSlf1, MSdf1, Rfd2, Rdf4 and Rdpu4. These are all exercises that require recognition (Rff1, Rfd2, Rdf4, Rdpu4) and translation (MSlf1, MSdf1) and reflect both conceptual fields that are being examined (fractions, decimals). We can observe that children of the second subgroup display similar behavior during the recognition of fractions and decimal numbers that are larger than 1 (Rfd2, Rdf4, Rdpu4).

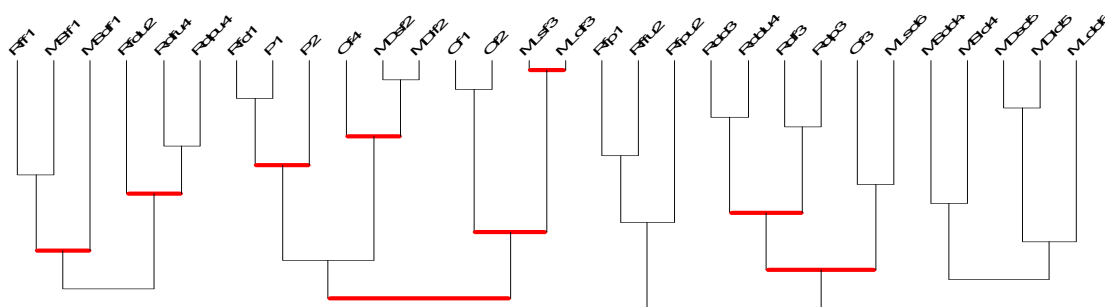

Diagram 1: Similarity diagram for the 5th grade

In the second group, it is obvious that the responses of the students to the four tests have been split into two subgroups, in which there is no compartmentalization according to the cognitive subject, since in each subgroup exercises from different tests appear (recognition, flexible handling, translation). There is a strong connection between exercise MLsf3 which involves the translation of a verbal expression to a symbolic expression (addition of dissimilar fractions) and exercise MLdf3 which concerns the translation of a verbal expression to a diagrammatic expression (addition of dissimilar fractions) from the same source and conceptual field. A significant correlation is also observed between exercises P1 and P2 which are verbal exercises of conversion from one form of rational number to the other.

The third group comprises of exercises that mainly examine the ability of recognizing fractional and decimal numbers (Rfp1, Rffu2, Rffu2, Rdd3, Rdd4, Rdf3, Rdp3), while there are only two exercises that involve flexible handling (Of3) and translation from one representation form to the other (MLsd6).

The fourth group comprises of exercises from Test C, which are exercises of translation from one representation system to the other (MSdd4, MSld4, MLdd6, MDld5 και MDsd5). This particular group consists of two subgroups which are not very closely connected. In the first group there is a grouping of exercises with a symbolic source,

while in the second group there is a grouping of exercises that mainly start with a diagrammatic representation. This fact obviously underlines a compartmentalization towards the two representations.

The implicative diagram in Figure 2 derived from the implicative analysis of the data and contains implicative relations, indicating whether success to a specific task implies success to another task related to the former one. The implicative relationships that arise through the translation exercises are intra-relational or intra-representational. The intra-relational implicative relationships are about the same concept, while the intra-representational relationships are about the same representation field. The inferences in bright red color are statistically significant at the 99% level of significance, while those in blue are significant at the 95% level of significance. Based on the implicative diagram we can see that almost all of the variables are correlated.

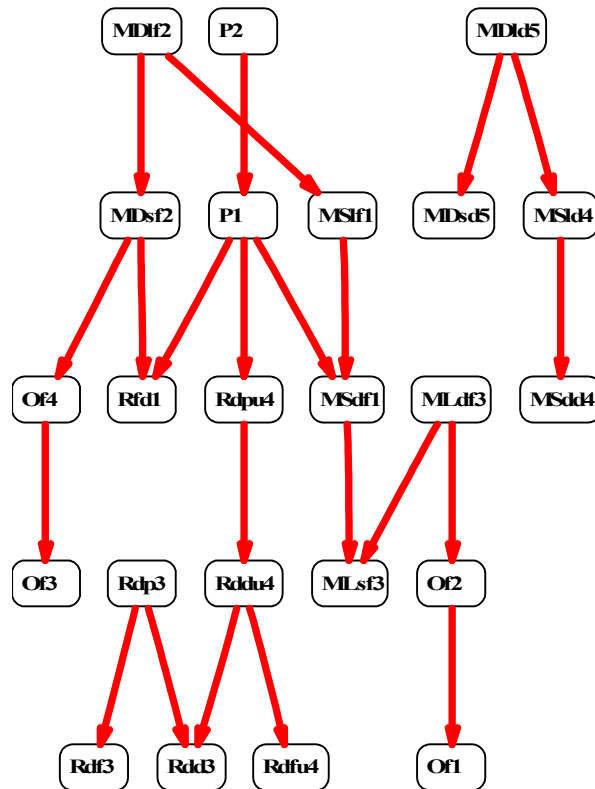

Diagram 2: Inferential diagram for the 5th grade

At the peak of the implicative diagram (diagram 2) exercises of Tests C and D are presented, which are exercises of translation from one representation system to the other and verbal exercises of conversion from one form of rational number to the other respectively (P1, P2, MDIf2, MDsf2, MSIf1). A fact that outlines the difficulty that students encounter both in exercises of translation and in exercises of conversion from fractional to decimal numbers and vice versa, in problem-solving situations. At the base

of the inferential diagram we can see exercises of recognition and flexible handling of fractions and decimal numbers, a fact that underlines an ease of handling these particular fields by the students (Rdf3, Rdd3, Rdfu4, Of1).

For the 6th grade (diagram 3), the responses of the students in the four tests have been split into two groups, in both of which, however, there is no compartmentalization of cognitive subjects, since in each group we can see exercises from different tests (recognition, flexible handling, and translation).

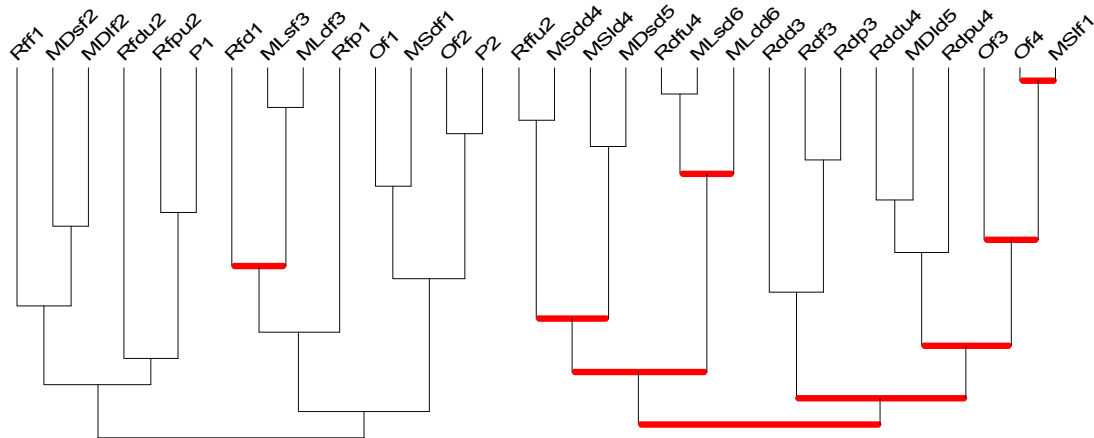

Diagram 3: Similarity diagram for the 6th grade

At the peak of the implicative diagram of the 6th grade (diagram 4) we can see exercises from tests C and D, which are exercises on the ability to translate from one representation system to another and verbal exercises of translation from one form of rational number to the other respectively (P1, P2, MLdd6, MDf2, MSdd4, MSld4). A fact that underlines the difficulty that students are having in both exercises of translation and exercises of conversion from fractional to decimal numbers and vice versa, through problematic situations. At the base of the implicative diagram we can find exercises of recognition and flexible handling of fractions and decimal numbers, a fact that underlines the ease that students have when dealing with these fields (Of1, Of3, Of4, Rdd3, Rddu4, Rdf3).

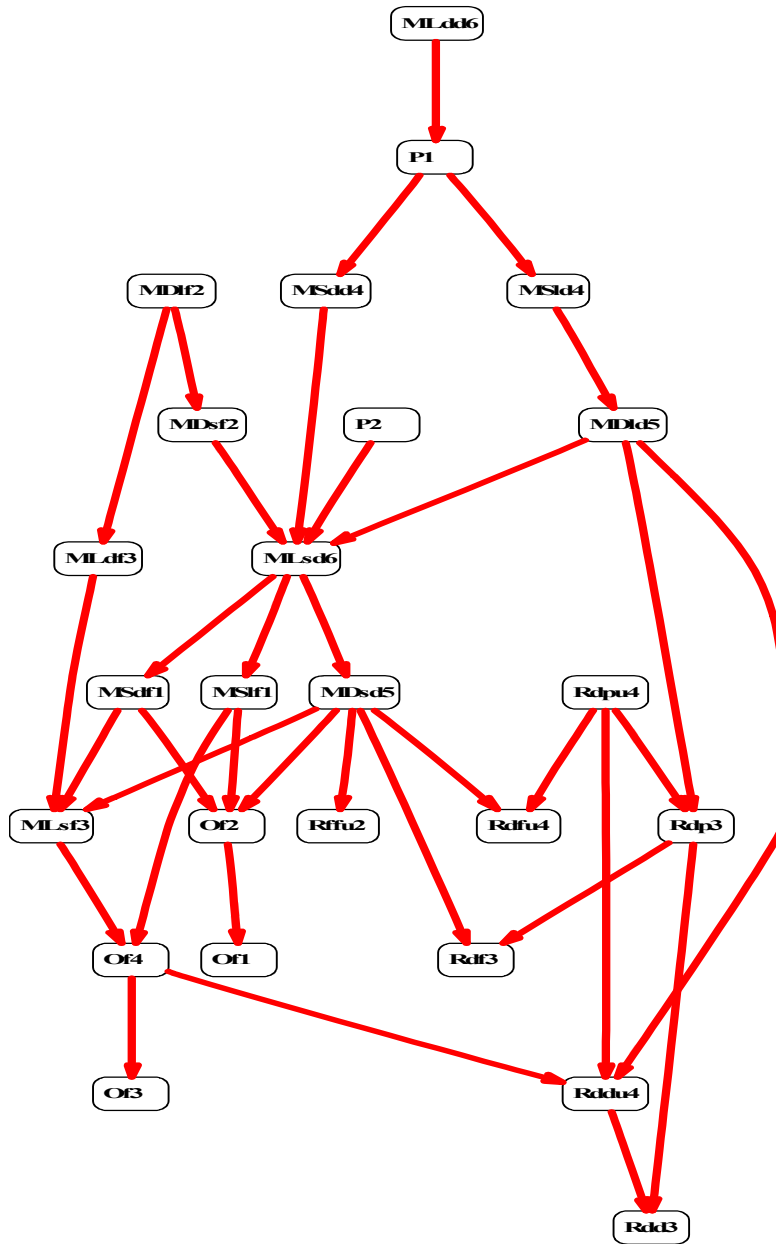

Diagram 4: Inferential diagram for the 6th grade

Below we shall answer the questions that were addressed at this phase using the proper statistical methods from the SPSS software.

What is the reliability index of these tests?

Gronbach’s Alpha Model was used to examine the reliability index. In order to establish reliability, which would be defined as internal consistency in the statements of the test, that index would have to be $\alpha > 0.70$. The reliability index of the tests which were used in

the present study was $\alpha=0.89$ for the 5th grade and $\alpha=0.91$ for the 6th grade respectively, both of which show high reliability.

Table 1: Success rate in the four types of tests according to grade.

Test parts	Test content	5th Grade	6th Grade
Test A	Recognition	72%	75%
Test B	Flexible handling	77%	76%
Test C	Translation	42%	31%
Test D	Exercises	30%	22%
Total performance		55%	51%

Table 2: Comparison of average success rates by type of test.

Test parts	Importance indicator 5th – 6th (p)
Test A: Recognition	0,144
Test B: Flexible handling	0,479
Test C: Translation	0,734
Test D: Exercises	0,625
Total performance	0,108

The highest success rates are observed in table 1, in tests A and B which measure the ability to recognise fractions and decimal numbers within different representation systems, and the flexible handling of fractions and decimal numbers within a representation system. The lowest success rates are observed in tests C and D, which test the ability to translate from one representation system to another and in the exercises with fractions and decimal numbers. It is worth mentioning that the total performance rate in the 5th grade was 55%, as compared to 51% in the 6th grade.

Based on the results presented in table 1, it is clear that 5th grade students present only slightly superior success rates in all the tests, with the exception of test A (recognition). A comparison of average success rates of students in the two grades (table 2) did not yield statistically significant differences in any of the four tests, nor in the students' total performance ($p>0.05$).

Table 3: 5th and 6th grade success rates in fractions and decimal numbers (Tests A, B and C).

	5 th Grade	6 th Grade
Total fraction performance	65%	61%
Total decimal number performance	63%	60%

A comparison of the total performance in fractions and decimal numbers reveals that students of both the 5th and 6th grade present almost identical performances.

Conclusions

Based on the research results a compartmentalisation in terms of the cognitive subject in 5th grade tests was shown. Compartmentalisation in terms of the cognitive subject was not shown in 6th grade tests. Students in both grades handle initial representation-source exercises as different problems without the ability to recognise that the three different types of representation (symbolic, diagrammatic, verbal) comprise different types of expression of the same concept.

These results yielded only intra-relational relationships in both grades, relationships relating to the same concept, a fact which shows that the ability to translate to different representation fields has not been established.

Furthermore, it is worth mentioning that at the top of the co-inferential diagram in both grades 5 and 6 we find exercises from tests C and D, which are exercises that relate to the ability to translate from one representation system to another, and verbal conversion exercises, converting from one type of rational number to another, respectively. This shows the students' difficulty in translation exercises, as well as in exercises that relate to the conversion from fractional to decimal numbers (and vice versa) in problematic situations. At the base of the inferential diagram we find exercises of recognition and flexible handling of fractions and decimal numbers, which suggests that these particular fields are handled by the students with more ease. Rates of success in the four tests of the two grades lead to the same conclusions. Tests A and B yielded the highest success rates, while tests B and C yielded the lowest success rates. This result confirms previous findings, according to which the algorithmic approach and the emphasis on procedural knowledge with reference to the teaching of fractions and decimal numbers presents difficulties in the comprehension of rational numbers, since the rules and processes are implemented mechanically (Philippou & Christou, 1994).

The students had difficulty in solving verbal conversion exercises from one type of rational number to the other. It was shown that students of both grade 5 and 6 do not realise the need to convert the two types of rational numbers into one in order to successfully complete the exercise. In many cases they tried to complete the exercises by implementing qualities of whole numbers. This result is in accordance with research

results, according to which the implementation of rules and algorithms which have no meaning results in a superficial comprehension of the concept of rational numbers and the difficulty in finding solutions to exercises with rational numbers (Ball, 1993; Philippou & Christou, 1994).

In terms of success in the four tests, no statistically significant differences were observed in the vast majority of the exercises between the two grades, a fact which suggests that de-compartmentalisation of the different representation fields has not been established in the progression from one grade to the next.

A comparison of the total performance in fractions and decimal numbers revealed that students of the 5th and 6th grade presented the same results. This shows that these two mathematical concepts (fractions and decimal numbers) are taught and comprehended on an equal basis.

Comprehension of a mathematical concept is achieved in 3 different stages at least: the recognition of a mathematical concept through different representational systems, the flexible handling of the concept within a representational system and the ability to translate from one representational system to another (Janvier, 1987). Therefore, the concept of fractions and decimal numbers must be presented to students in all the different fields of expression (symbolic, verbal and diagrammatic) in order to avoid a segmental approach to the various representations of the concepts. Teachers should aim to achieve similar success rates on the part of the students, regardless of the representation system used in the exercises. The representations performed by the children comprise an integral part of their mathematical comprehension. It is possible for the teacher to ascertain what the students comprehend by watching and conversing with the students about their mathematical representations.

This study was limited to the examination of fractions and decimal numbers with reference mainly to the addition of dissimilar fractions and decimal numbers. Therefore, research into all the algorithmic operations, as well as percentages, would be very interesting. It is possible that such research might yield significant differences between the two grades.

References

- Ball, D.L. (1993). Halves, pieces and twos: Constructing and using representational contexts in teaching fractions. In T.P. Carpenter, E. Fennema and T.A. Romberg (eds.), *Rational Numbers: An Integration of Research*, Lawrence Erlbaum, Hillsdale, NJ, 157-195.
- Cheng, P.C.H. (2000). Unlocking conceptual learning in mathematics and science with effective representational systems. *Computers and Education*, 33, 109-130.
- Confrey, J. (1994). Splitting, similarity, and the rate of change: A new approach to multiplication and exponential functions. In G. Harel & J. Confrey (Eds.), *The*

development of multiplicative reasoning in the learning of mathematics (pp. 291-330). Albany: State University of New York Press.

- Duval, R. (2002). The cognitive analysis of problems of comprehension in the learning of mathematics. *Mediterranean Journal for Research in Mathematics Education*, 1 (2), 1-16.
- Evangelidou, A., Spyrou, P., Elia, I., & Gagatsis, A. (2004). University students' conceptions of function. In M. Johnsen Høines & A. Berit Fuglestad (Eds.), *Proceedings of the 28th Conference of the International Group for the Psychology of Mathematics Education* (Vol. 2, pp. 351-358). Bergen, Norway: Bergen University College.
- Even, R. (1998). Factors involved in linking representations of functions. *The Journal of Mathematical Behavior*, 17(1), 105-121.
- Griffin, S., & Case, R. (1997). Re-thinking the primary school math curriculum: an approach based on cognitive science. *Issues in Education*, 3(1), 1-49.
- Gagatsis, A., & Shiakalli, M. (2004). Ability to translate from one representation of the concept of function to another and mathematical problem solving. *Educational Psychology*, 24 (5), 645-657.
- Gagatsis, A., Shiakalli, M., & Panaoura, A. (2003). La droite arithmétique comme modèle géométrique de l'addition et de la soustraction des nombres entiers. *Annales de didactique et de sciences cognitives*, 8, 95-112.
- Gagatsis, A., Michaelidou, E., & Shiakalli, M. (2001). *Representation theories in mathematics learning* (in greek). Nicosia: Erasmus IP1.
- Greeno, J. G., & Hall, R.P. (1997). Practicing representation: Learning with and about representational forms, *Phi Delta Kappan*, 78, 361-367.
- Hitt, F. (1998). Difficulties in the articulation of different representations linked to the concept of function. *The Journal of Mathematical Behavior*, 17(1), 123-134.
- Janvier, C. (1987). Representation and understanding: The notion of function as an example. In C. Janvier (Ed.), *Problems of Representation in the Teaching and Learning of Mathematics* (pp.67-71). Hillsdale, NJ: Lawrence Erlbaum.
- Kaput, J. (1992). Technology and mathematics education. In D. A. Grouws (Ed.), *Handbook of research on mathematics teaching and learning* (pp. 515-556). New York: Macmillan.

- Kaput, J. J. (1987). Representation systems and mathematics. In C. Janvier (Ed.), *Problems of representation in the teaching and learning of mathematics* (pp. 159-195). Hillsdale, NJ: Lawrence Erlbaum.
- Lesh, R., Post T, & Behr, M. (1987). Representations and translations among representations in mathematics learning and problem solving. In C. Janvier (Ed.), *Problems of representation in the teaching and learning of mathematics* (pp. 33-40). Hillsdale, N.J.: Lawrence Erlbaum Associates.
- Lummis, M., & Stevenson, H.W. (1990). *Gender Differences in Beliefs and Achievement: A Cross-Cultural Study*. *Developmental Psychology*, 26(2), 254-263.
- Mack, N. K. (1990). Learning fractions with understanding: Building on informal Knowledge. *Journal for Research in Mathematics Education*, 21(1), 16-32.
- Philippou, G.N. & Christou, K. (1994). *Prospective elementary teachers' conceptual and procedural knowledge of fractions*. In J.P Ponte & J.P Matos (Eds), *Proceedings of the PME 18, (Conference of the International Group of the Psychology of Mathematicw Education)*, Vol. IV, 33 – 40.
- Romberg, T. A., Fennema, E., & Carpenter, T. P. (Eds.). (1993). *Integrating research on the graphical representation of functions*. Hillsdale, NJ: Erlbaum.
- Yang, D., & Huang, F. (2004). Relationships among computational performance, pictorial representation, symbolic representation and number sense of sixth-grade students in Taiwan. *Educational Studies*, 30(4), 373-389.
- Vinner, S., & Dreyfus, T. (1989). Images and definitions for the concept of function. *Journal for Research in Mathematics Education*, 20(4), 356-266.

CHAPTER 2

Teaching and Learning of Geometry



Spatial abilities in relation to performance in items involving net-representations of geometrical solids

Georgia Panaoura & Athanasios Gagatsis

Department of Education, University of Cyprus

Abstract

In this paper we (a) empirically test and validate a model which identifies three subcomponents of spatial ability (image manipulation, mental rotation, and coordination of perspectives and frames of reference) and (b) examine the relation between primary (grades 4 and 6) and secondary school (grade 8) students' spatial abilities and their performance in tasks involving net-representations of geometrical solids. Path analysis revealed that “spatial ability”, described by the three aforementioned constructs, constitutes a good predictor of students' performance in geometry tasks involving net-representations of solids. The similarity analysis revealed that, while 4th graders work with tasks involving nets of geometrical solids in a different way than with spatial ability tasks, this is not the case for the older students. The findings imply that 6th and 8th graders begin to realize that the same cognitive processes underlie spatial abilities tasks and manipulation of items involving net-representations of geometrical solids.

Introduction

Geometry and spatial reasoning are important as a way to interpret and reflect on the physical environment. As Bishop (1983) has noted, geometry is the mathematics of space. Mathematics educators, therefore, are concerned with helping pupils gain knowledge and skills in the mathematical interpretations of space.

Research in geometry and spatial thinking has evolved from studies in psychology, when in the 1970s some researchers were interested in the relationship of spatial abilities to mathematical learning and problem solving (Owens & Outhred, 2006). Research on spatial ability as a single component has indicated that it has a strong connection with achievement in mathematics (Clements and Battista, 1992). However, researchers now agree that spatial ability is not a unitary construct, so it would be useful to investigate how clearly defined subcomponents of spatial ability are related to students' performance in certain geometry tasks.

A number of studies in geometry education have focused on the ways in which children visualize and represent their space and, especially, on the representations of geometrical solids on a plane (Potari & Spiliotopoulou, 2001). In this paper we chose to study three

spatial ability subcomponents (Demetriou & Kyriakides, 2006) i.e. image manipulation, mental rotation, and coordination of perspectives and frames of reference, in relation to students' performance in tasks involving net-representations of geometrical solids. The subject 'net-representations of solids' appears in mathematics curricula in the geometry section. However, it is a subject which by nature, we could say, seems to be related to spatial abilities, since it involves processes like folding, rotating, transforming. This study aims to examine students' performance in the specific subject in relation to their spatial abilities.

Theoretical background and research questions

Spatial abilities

When mathematics educators consider geometry from a theoretical perspective, the key role of spatial abilities is universally accepted. In many countries the development and improvement of spatial ability is regarded to be one of the basic aims of geometry in elementary school (Reinhold, 2002), since "spatial understandings are necessary for interpreting, understanding, and appreciating our inherently geometric world" (NCTM, 1989, p. 48). Furthermore, for many mathematics educators, spatial ability is regarded an important prerequisite for geometry problem solving in particular, and by some researchers even for mathematics learning in general. High levels of spatial abilities have frequently been linked to high performance in mathematics in general, but little is known about the relation of spatial abilities and students' performance in different geometry tasks. But, what is the meaning of the term "spatial abilities"?

According to Demetriou's theory (Demetriou & Kazi, 2001), the spatial-imaginal specialized structural system of the human mind is directed to those aspects of reality which can be visualized by the "mind's eye" as integral wholes and processed as such. Generally speaking, the concept of spatial ability is used for the abilities related to the use of space and implies the generation, retention, retrieval, and transformation of well-structured visual images (Lohman, 1996) or visuo-spatial information (Colom, Contreras, Botella, & Santacreu, 2001). Psychologists as well as mathematics educators have contributed to the discussion of how spatial ability may be understood. But, as Wheatley (1998) has noted, the way the term spatial ability (and other related terms) have been defined and the instruments used to collect data are nearly as varied as the number of studies using this term.

Nevertheless, researchers agree that spatial ability is not a unitary construct. Different components of "spatial ability" have been identified as a result of a number of analytic studies, each emphasizing different aspects of the process of image generation, storage, retrieval, and transformation. The three dimensions of spatial ability that are commonly addressed are spatial visualization, spatial relations and spatial orientation. Spatial visualization involves the ability to imagine the movements of objects, and spatial visualization tasks (e.g. paper folding tasks) require mental manipulation of images. Spatial relations tasks involve manipulations such as mental rotations. Spatial orientation tests are designed to engage the self-to-object representational system.

In the present study, we follow Demetriou and Kyriakides (2006) argument that there are three components related to the spatial-imaginal specialized structural system of the human mind: image manipulation, mental rotation, and coordination of perspectives and frames of reference.

Net-representations of geometrical solids

In attempting to investigate how space is perceived and interpreted by individuals, researchers examine the two-way relation between three-dimensional objects and their two-dimensional representations (Hershkowitz, 1990). A number of studies in geometry education have focused on the representations of geometrical solids on a plane (Potari & Spiliotopoulou, 2001). One might think of many different plane representations of solids, such as orthogonal, isometric or, by layers. In this paper we study net-representations of geometrical solids, i.e. the two-dimensional figures which can be folded to form a solid. A net has been described by Borowski and Borwein (1991) as a diagram of a hollow solid consisting of the plane shapes of the faces so arranged that the cut-out diagram could be folded to form the solid.

In the case of nets of solids, children's conceptions can be considered as mental representations rather than iconic. The whole process of developing solids is a mental construction that requires the child not only to "see" the objects and recognize their elements, but also to combine the latter in a transformed position and probably take into consideration the reverse process (Potari & Spiliotopoulou, 2001). This procedure implies that a manipulation and analysis of the single components of the object (faces, vertices and edges) takes place. Such geometrical thinking requires the total fusion of the conceptual and figural aspects of the concept.

In the literature one can identify two main strands of articles referring to nets of solids. On the one hand, researchers explore students' strategies and reasoning when they work with tasks involving net-representations of solids. For example, in a study conducted by Stylianou, Leikin, & Silver (1999) with eighth grade students, the researchers focused on students' problem-solving strategies when constructing different types of nets of cube. Potari & Spiliotopoulou (1992, 2001) attempted to study the process of developing physical objects and explore the characteristics of children's representations. On the other hand, there are articles where series of lessons are described and useful suggestions are provided for the teaching of net-representations of solids (e.g., Mistretta, 2000; Woodward & Brown, 1994).

The present study

The aim of the present study is twofold. First, we investigate the structures of primary and secondary school students' spatial ability. To this end, we test a theoretically driven model about the constructs of spatial ability using empirical data to validate it. Second, we examine whether and how students' spatial abilities are related to their performance in tasks involving net-representations of geometrical solids. The second aim is analyzed into the following research questions:

- Is students' spatial ability a predictor to their performance in tasks involving net-representations of geometrical solids?
- Do primary and secondary school students confront spatial ability tasks and items involving nets of geometrical solids in a similar or in a different way?
- Do implicative relations exist amongst spatial ability tasks and geometry tasks involving net-representations of geometrical solids?

So, in this study we investigate the relation between students' spatial abilities and their geometry performance in tasks involving net-representations of geometrical solids, trying to extend the research on geometry and spatial thinking in three ways: First, we accept that spatial ability is not a unitary construct and we propose a model which integrates three spatial ability subcomponents: image manipulation, mental rotation, and coordination of perspectives. Second, in our model we propose that students' spatial ability is a possible predictor of students' performance in tasks involving net-representations of geometrical solids. Third, we make a further step towards the relation of spatial abilities and geometry performance trying to gather information on the tasks' level investigating the existence of similarity and implicative relations amongst spatial ability tasks and geometry tasks involving net-representations of geometrical solids. At this point, we should clarify that students' performance in geometry tasks involving net-representations of geometrical solids is described here across two dimensions: (a) performance in tasks involving net-representations of a cube, and (b) performance in tasks involving net-representations of other geometrical solids.

Method

Participants

The participants were 1000 primary and secondary school students (488 males and 512 females). Specifically, 332 were 4th graders (10 years old), 333 were 6th graders (12 years old) and 335 were 8th graders (14 years old).

Materials and Procedure

Data were collected through a written test which was administered to all students of the three age groups and consisted of spatial ability tasks and geometry items. The test was administered in two parts during normal teaching.

The choice of the geometry tasks involving nets of geometrical solids was based on some previous research work we did about children working with nets (Panaoura & Gagatsis, 2003). Additionally, the choice of the tasks was made taking into consideration the geometry curriculum in Cyprus and the net-representations tasks presented in mathematics books at the primary education level. The geometry test included tasks referring to nets of cube and to nets of other geometrical solids: net-of-cube drawing task, net-of-cube completing task, nets-of-solids recognition tasks, and problems involving both the drawing and the net of a solid. Examples of the items used can be found in the Appendix.

The spatial ability battery test administered consisted of tasks used by Demetriou and his associates in their studies of mind (for full description of the tasks, see Demetriou & Kyriakides, 2006). It included tasks addressed to image manipulation (*paper folding* task), mental rotation (*cubes* task and *clock* task), and coordination of perspectives (*tilted bottle* task and *car* task). Each item involved was scored on a pass (1) / fail (0) basis. The total task score equaled the number of items passed by the participant.

Statistical Analyses

With the use of the Extended Logistic Model of Rasch (Rasch, 1980), an interval scale presenting both item difficulties and students' performance was created (a) for the net-representations test and (b) for the spatial abilities test. Data analysis revealed that the two batteries of tests had satisfactory psychometric properties, namely construct validity and reliability.

The assessment of the proposed model was based on a confirmatory factor analysis (CFA). Specifically, the data was first analyzed by using CFA to assess the fit of the hypothesized a-priori model about the three components of spatial ability (image manipulation, mental rotation and, coordination of perspectives) to the data. Path analysis was used to investigate the relation between students' spatial abilities and their performance in net-representations tasks.

EQS computer program (Bentler, 1995) was used to test the proposed models and three fit indices were examined, in order to evaluate the extent to which the data fit the models tested: the chi-square to its degrees of freedom ratio (χ^2/df), the comparative fit index (CFI), and the root mean-square error of approximation (RMSEA). The observed values for χ^2/df should be less than 2, the values for CFI should be higher than 0.9, and the RMSEA values should be lower than 0.08 to support model fit (Marcoulides & Schumacker, 1996). Additionally, the factor parameter estimates for the model with acceptable fit were examined to help interpret the model.

Gras's similarity and implicative statistical analyses were conducted by using the computer software CHIC (Classification Hiérarchique Implicative et Cohésitive) (Bodin, Coutourier, & Gras, 2000). For the purposes of this paper, we refer to the similarity diagrams and implicative graphs produced by CHIC when conducting similarity and implicative analysis of the data. A similarity diagram allows for the arrangement of tasks into groups according to their homogeneity. An implicative graph contains implicative relations, which indicate whether success to a specific task implies success to another task related to the former one. A similarity diagram and an implicative graph were produced for each age group. Due to space limitations, we do not present all six diagrams here, but we sum up the observations that arise from them.

Results

The main findings of this study are presented in two sections. In the first section, we present the findings of confirmatory factor analyses which were conducted to assess the proposed model. The second section elaborates on the similarity and implicative

statistical analysis conducted based on students' performance in spatial ability and net-representations tasks.

The three constructs of spatial ability and the relation to performance in net-representations tasks

In this study we proposed a theoretically driven model about the components of spatial ability: image manipulation, mental rotation, and coordination of perspectives. This model consisted of three first-order factors and one second-order factor. The first-order factors represented the components of spatial ability: image manipulation (F1), mental rotation (F2), and coordination of perspectives (F3). The above three factors were hypothesized to construct a second-order factor "spatial abilities" (F4) that is postulated to account for any correlation or covariance between the first-order factors. The spatial ability model is presented on the left-hand side of Figure 1.

The fit of the spatial ability model was very good. The descriptive-fit measures indicated support for the hypothesized first and second order latent factors [$\chi^2(42)=59.99$; CFI=0.996; RMSEA = .019 (.001, .030)].

After validating the model describing spatial ability as a construct of the three aforementioned factors, path analysis was used to investigate the relation between students' spatial abilities and their performance in net-representations tasks. The proposed model incorporated the spatial ability factor as described in the previous model and a second-order net-representations performance latent factor. The model hypothesized that the variables of the net-representations test would be explained by two first-order factors. In particular, we assumed that one of the first-order factors would be measured by the tasks involving net-representations of cube (F5). This assumption was based on previous research findings (Panaoura & Gagatsis, 2003) suggesting that 4th and 6th graders confront different net-of-cube representation tasks in a similar way. We assumed that the other first-order factor (F6) would correspond to the scores of the tasks involving net-representations of geometrical solids other than the cube. So, the validity of a model where the second-order latent variable "net-representations performance" (F7) is regressed on the second-order latent factor "spatial abilities" (F4) was tested, assuming a causal effect between spatial ability and net-representations performance (Figure 1).

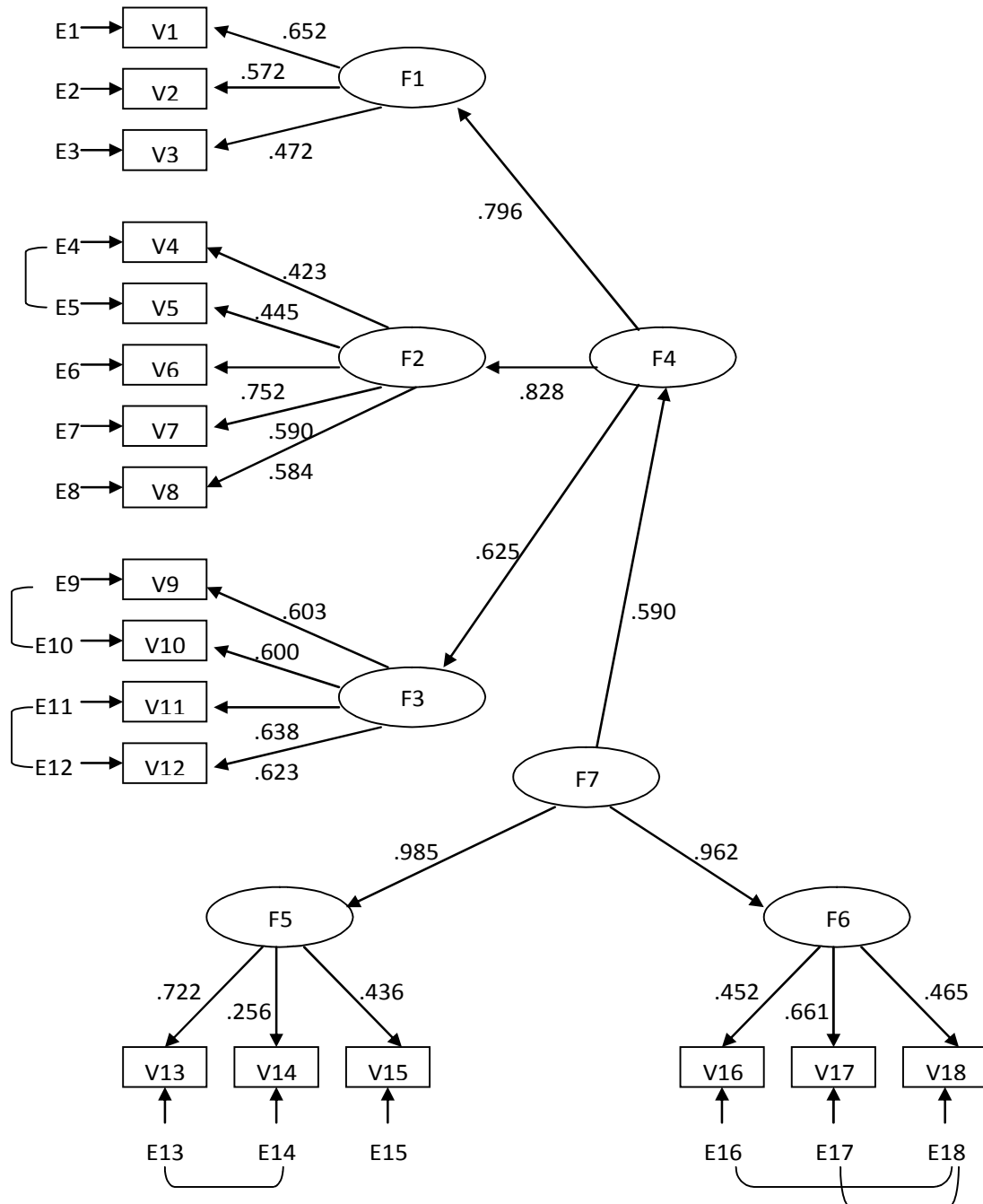

*Figure 1: The structure of the proposed model**

*V1-V12 refer to the spatial ability tasks, V13-V18 refer to the net-representations tasks, F1=Image Manipulation, F2=Mental Rotation, F3=Coordination of Perspectives, F4=Spatial Abilities, F5=Performance in tasks involving net-representations of cube, F6=Performance in tasks involving net-representations of other solids, F7=Net-representations Performance

The model fitted the data and fitting indices were adequate to provide evidence that supported the relation implied in it [$\chi^2(118)=188.708$; CFI=0.985; RMSEA =.024 (.018, .031)]. The regression coefficient of spatial ability on net-representations performance gave evidence to the assumption that spatial ability is a predictor of net-representations performance.

Similarity and Implicative Analyses Results

The objective of conducting Gras's similarity analysis was to examine whether students of the three different age groups confronted spatial ability tasks and net-representations tasks in a similar or in a different way.

Figure 2 illustrates the similarity diagram of all variables (tasks involving net-representations of geometrical solids and spatial abilities items) for the 4th grade students. Students' responses to the tasks are responsible for the formation of four clusters (i.e. groups of variables) of similarity. The two first groups consist of geometry tasks involving nets, while the third and fourth group consists of spatial abilities items. The first cluster is formed by the tasks involving nets of cube. Cube is perhaps the most familiar geometric solid to the students of this age, and it is the one widely used in geometry lessons to introduce the concept of nets of solids. So, all the tasks involving net-representations of cube were confronted by the 4th graders in a similar way. The second cluster is formed by all the other tasks involving nets of geometrical solids.

No relation is observed between nets-representations clusters and spatial abilities clusters. This implies that 4th grade students confront tasks involving nets of geometrical solids in a different way than with spatial abilities items. They do not see any similarity in the cognitive processes that underlie these two kinds of tasks. This is partly the case for 6th grade students, as revealed from the similarity analysis. Most of the tasks involving nets of geometrical solids were confronted in a different way than spatial abilities tasks. But, in the corresponding similarity diagram some net-representations items appeared in the same group of variables with spatial abilities items. Specifically, two items involving nets of cube were confronted in a similar way as spatial items referring to folding figures, while two other nets-of-cube tasks were confronted in a similar way to spatial tasks involving rotation. So, 6th grade students begin to realize that the same cognitive processes underlie certain spatial abilities and manipulating net-representations of cube.

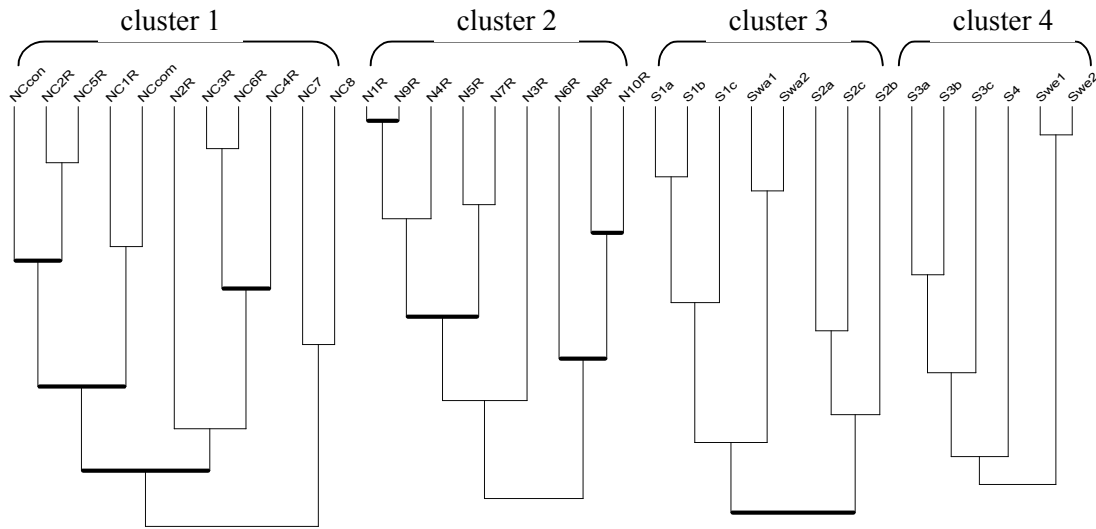

Figure 2: Similarity diagram of the variables of net-representations test and spatial abilities test for the 4th grade students

Note: Items with ‘N’ as a first index refer to net-representations tasks. Items with ‘S’ as a first index refer to spatial abilities tasks.

In Figure 3, all the similarity relations of the net-representations tasks and the spatial abilities items which refer to the responses of the 8th grade students are illustrated. As in Figure 2, four distinct similarity groups are formed. But in this figure, in contrast to the previous one, only the fourth cluster consists of tasks of the same category, namely spatial abilities tasks. What is interesting in this similarity diagram is the fact that the other three clusters of similarity consist of both spatial abilities and net-representations items, indicating that these students have confronted net-representations tasks in a similar way to spatial abilities items.

The way students have confronted spatial ability tasks in relation to the geometry tasks involving nets of solids differentiated in relation with their age. More specifically, in the case of 4th graders, tasks involving nets of solids were confronted in a totally different way than the spatial ability items. The young students could not see any similarity in the underlying geometrical concepts. But in the case of 6th graders and more clearly in the case of 8th graders the involvement of spatial ability tasks in the same clusters with net-representations items provided evidence that the older students realize to a bigger extent that the same cognitive processes underlie spatial abilities and manipulating net-representations of geometrical solids.

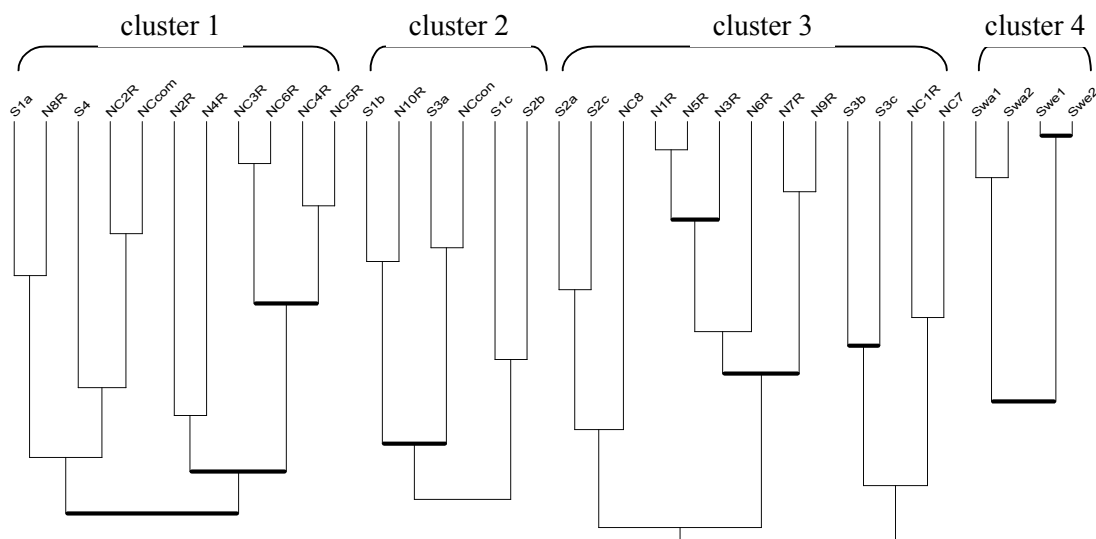

Figure 3: Similarity diagram of the variables of net-representations test and spatial abilities test for the 8th grade students

Note: Items with ‘N’ as a first index refer to net-representations tasks. Items with ‘S’ as a first index refer to spatial abilities tasks.

The objective of conducting Gras’s implicative analysis was the investigation of the presence of any implicative relations between spatial ability and net-representations tasks. As mentioned above, the implicative graphs produced contain implicative relations, which indicate whether success on a specific task implies success on another task related to the former one.

Though in the case of the younger students (4th graders), no implicative relations were observed between nets items and spatial ability tasks, this was not the case for the older students. Apart from intra-categorical relations, the analysis revealed a number of implicative relations between tasks from the two different categories: nets items leading to spatial ability tasks and spatial ability tasks leading to tasks referring to nets. In the older students’ minds, we might think, there are not only intra-categorical relations, but it seems that successful performance on tasks involving nets of geometrical solids implies success on spatial ability tasks and vice versa.

Discussion

In this paper we have tried to extend the research on geometry and spatial ability. Specifically, confirmatory factor analysis has been employed to explore the structural organization of three distinct dimensions of spatial ability, as proposed by Demetriou and Kyriakides (2006) (image manipulation, mental rotation and coordination of perspectives), and we investigated how spatial abilities are related to primary (grade 4

and grade 6) and secondary (grade 8) students' geometry performance in tasks involving net-representations of geometrical solids.

First, the proposed model proved to be consistent with the data, leading to the conclusion that image manipulation, mental rotation, and coordination of perspectives mediate students' spatial ability. Additionally, path analysis revealed a causal effect between students' spatial ability and their performance in tasks involving net-representations of geometrical solids, indicating that spatial ability constitutes a good predictor of students' performance in this kind of tasks. This finding suggests that an improvement of students' aforementioned spatial abilities may result to an improvement of their specific geometrical performance.

Furthermore, we made a further step towards the relation of spatial abilities and geometry performance by investigating the existence of similarity and implicative relations between spatial ability tasks and geometry tasks involving net-representations of geometrical solids. The similarity and implicative analyses conducted in the study provided evidence that only the students in grade 4 considered the tasks involving nets of geometrical solids totally different from the spatial abilities tasks. Younger students did not recognize any similarities between those two categories of tasks, while the older students in the study confronted a number of tasks involving nets similarly to spatial abilities tasks. This implies that the older students could realize that the same cognitive processes underlie spatial abilities such as image manipulation and mental rotation on the one hand, and manipulating net-representations of geometrical solids on the other. This finding is in line with Potari's and Spiliotopoulou's proposition that the whole process of developing solids and handling their net-representations requires the student not only to "see" the objects and recognize their elements, but also to mentally "combine the latter in a transformed position and probably take into consideration the reverse process" (Potari & Spiliotopoulou, 2001, p. 41).

In addition to extending the research literature on the relation of students' spatial abilities and their performance in net-representations tasks, this research may enhance information available to curriculum designers and teachers. Working with nets means that a student activates cognitive processes also used when confronting spatial ability tasks involving folding or rotating abilities. But, additionally, working with nets involves geometrical knowledge concerning, for example, the shape and numbers of the faces of a certain geometrical solid. So, some useful instructional implications can be drawn from this study's findings. In most mathematics curricula there is not explicit focus on teaching and developing students' spatial abilities. Although it was not our intent in this paper to make claims about specific aspects of an instructional program, the results of this study provide preliminary evidence that the cognitive processes of image manipulation, mental rotation and coordination of perspectives can be used in mathematics classroom in a way that may enhance students' geometrical performance. Our findings make us consider once again the idea that systematic training in spatial abilities should be one of the aims of teaching geometry. The challenge is for curriculum designers and classroom mathematics teachers to devise strategies for helping students improve the state of connectedness of their abilities; in this case, to

help them see the relation of spatial abilities to net-representations of geometrical solids and other subjects of geometry.

References

- Bentler, P.M. (1995). *EQS Structural Equations Program Manual*. Encino, CA: Multivariate Software Inc.
- Bishop, A. (1983). Space and geometry. In R. Lesh and M. Landau (Eds.), *Acquisition of mathematics concepts and processes* (175-203). New York: Academic Press.
- Bodin, A., Couturier, R., & Gras, R. (2000). *CHIC: Classification Hierarchique Implicative et Cohesive – Version sous Windows*. Rennes: Association pour le Recherche en Didactique des Mathématiques.
- Borowski, E., & Borwein, J. (1991). *The Harper Collins Dictionary of Mathematics*. New York: Harper Collins Publishers.
- Clements, D. H. & Battista, M. (1992). Geometry and spatial reasoning. In D. A. Grouws (Ed.), *Handbook of research on mathematics teaching and learning* (pp.420-464). New York: MacMillan.
- Colom, R., Contreras, M.J., Botella, J., and Santacreu, J. (2001). Vehicles of spatial ability. *Personality and Individual Differences*, 32, 903-912.
- Demetriou, A., & Kazi, S. (2001). *Unity and Modularity in the Mind and the Self*. London: Routledge.
- Demetriou, A., & Kyriakides, L. (2006). The functional and developmental organization of cognitive developmental sequences. *British Journal of Educational Psychology*, 76, 209-242.
- Hershkowitz, R. (1990). Psychological aspects of learning geometry. In P. Nesher & J. Kilpatrick (Eds.), *Mathematics and Cognition: A Research Synthesis by the International Group for the Psychology of Mathematics Education* (pp. 70-95). Cambridge: Cambridge University Press.
- Lohman, D.F. (1996). Spatial ability and g. In I. Dennis & P. Tapsfield (Eds.), *Human abilities: their nature and measurement* (pp.97-116). Mahwah: Lawrence Erlbaum Associates.
- Marcoullides, G. A., & Schumacker, R. E. (1996). *Advanced structural equation modeling: Issues and techniques*. Mahwah, NJ: Lawrence Erlbaum Publishing.
- Mistretta, R. (2000). Enhancing geometric reasoning. *Adolescence*, 35 (138), 365-379.
- National Council of Teachers of Mathematics (1989). *Curriculum and Evaluation Standards for School Mathematics*. Reston, VA: NCTM.

- Owens, K., & Outhred, L. (2006). The complexity of learning geometry and measurement. In A. Gutiérrez and P. Boero (eds.), *Handbook of Research on the Psychology of Mathematics Education* (pp. 83-115). Rotterdam: Sense Publishers.
- Panaoura, G., & Gagatsis, A. (2003). From three-dimensional space to the space of two dimensions. The representations of geometrical shapes. In A. Gagatsis & I. Elia, (Eds.), *Representations and Geometrical Models in the Learning of Mathematics: Vol. II* (pp. 153-178). Nicosia: Intercollege Press (in Greek).
- Potari, D., & Spiliotopoulou, V. (1992). Children's representations of the development of solids. *For the Learning of Mathematics*, 12(1), 38-46.
- Potari, D. and Spiliotopoulou, V. (2001). Patterns in children's drawings and actions while constructing nets of solids: the case of conical surfaces. *Focus on Learning Problems in Mathematics* 23(4), 41-62.
- Rasch, G. (1980). *Probabilistic Models for Some Intelligence and Attainment Tests*. Chicago: University of Chicago Press.
- Reinhold, S. (2002). Topology in elementary school mathematics – a contribution to the improvement of children's spatial ability? YERME Summer School Klagenfurt.
- Stylianou, D., Leikin, R., & Silver, E. (1999). Exploring students' solution strategies in solving a spatial visualization problem involving nets. In O. Zaslavsky (Ed.), *Proceedings of the 23rd International Conference for the Psychology of Mathematics Education*, 4 (pp.241-248). Israel: University of Haifa.
- Wheatley, G. H. (1998). Imagery and mathematics learning. *Focus on Learning Problems in Mathematics*, 20(2/3), 65-77.
- Woodward, E., & Brown, R. (1994). Polydrons and three-dimensional geometry. *Arithmetic Teacher*, 41 (8), 451-458.

Appendix : Examples of tasks used

(A) Net-representation item

Which of the following represent(s) a net of cube?
Circle your answer(s).

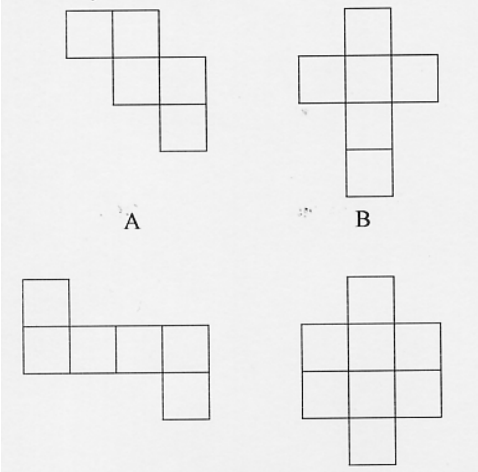

The image shows four different arrangements of six squares, labeled A, B, C, and D. Net A consists of a horizontal row of four squares, with one square attached to the top of the second square and one square attached to the bottom of the third square. Net B is a cross shape with a horizontal row of three squares, one square attached to the top of the middle square, one square attached to the bottom of the middle square, and one square attached to the bottom of the bottom square. Net C is a horizontal row of five squares, with one square attached to the top of the first square and one square attached to the bottom of the fifth square. Net D is a cross shape with a horizontal row of three squares, one square attached to the top of the middle square, one square attached to the bottom of the middle square, and one square attached to the bottom of the middle square.

A B C D

(B) Spatial ability item (image manipulation)

What will the piece of paper look like if it is folded around the axis?



The image shows an isosceles triangle with a vertical dashed line through its apex, representing an axis of symmetry. A curved arrow above the apex indicates a fold along this axis.

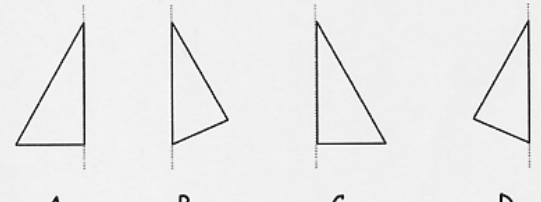

The image shows four possible resulting shapes, labeled A, B, C, and D, each with a vertical dashed line representing the axis of symmetry. Shape A is a right-angled triangle with the right angle at the bottom-left corner. Shape B is a right-angled triangle with the right angle at the bottom-right corner. Shape C is a right-angled triangle with the right angle at the bottom-left corner, but the hypotenuse is on the left side. Shape D is a right-angled triangle with the right angle at the bottom-right corner, but the hypotenuse is on the right side.

A B C D



Students’ motivational beliefs, metacognitive strategies and the ability to solve volume problems in different representations

Paraskevi Sophocleous, Eleni Michael & Athanasios Gagatsis

Department of Education, University of Cyprus

Abstract

The goal of this study was to investigate the relationships between students’ motivational beliefs: self-efficacy, task value and goal orientation, metacognitive strategies use and the volume measurement performance. A group of sixth grade students (N=173) completed a self-report questionnaire and solved six volume measurement of cuboid tasks given in different modes of representations (text, diagram of 3-D cube array, net diagram). Perceived efficacy to solve mathematical and volume measurement tasks was found to be a strong predictor of the general volume measurement performance. Further, students’ metacognitive strategies use predicted only their performance on the verbal volume measurement tasks. The factor of students’ self - representation of spatial ability was a statistically significant predictor of the achievement in one of the verbal tasks which required high spatial abilities to solve it. We also found statistically significant differences of self-efficacy beliefs among students who have high and low volume measurement performance. Many of the students used wrong strategies to volume measurement tasks with diagram of 3-D cube array or net diagram: counting the cube faces shown in the diagram or doubling that number.

Introduction

Research on mathematics teaching and learning has recently moved away from purely cognitive variables (Panaoura, 2007) and focused on affective variables, which were found to play essential role that influences behaviour and learning (Bandura, 1997). A number of researchers have examined thoroughly the connections and the relationship among affect and mathematics learning (Ma & Kishor, 1997; Philippou & Christou, 2001). However, although much work has been done in this area, little attention has been given to the relationship between affective variables, the use multiple representations in mathematics in general (e.g. Patterson & Norwood, 2004) and in specific areas of mathematics in particular.

Motivation is an important factor of students’ classroom learning and achievement, because numerous studies indicated that students who are more highly motivated tend to provide greater effort and persist longer at academic tasks than students who are less motivated (Pintrich & Schunk, 1996; Pintrich & Schrauben, 1992). Weiner (1990) claimed that various beliefs, attitudes and perceptions of the student affect his/her

motivation. Especially, task value beliefs, students' perceived self-efficacy, and the goals orientation beliefs comprise components of the motivational beliefs system (Wolters & Rosenthal, 2000).

Additionally, metacognitive knowledge is another important factor for successful performance on mathematical problem solving. Students benefited from training that was sensitive to the metacognitive demands of the task, that is from learning when and how to apply learning strategies (Mayer, 1998). Specifically, metaskills involves knowledge of when to use, how to coordinate, and how to monitor various skills in problem solving (Mayer, 1998).

In this paper we try to investigate the relationships between motivational beliefs to solve mathematics problems generally and volume measurement tasks specifically, metacognitive strategies employed to solve mathematical problems and performance on volume measurement of cuboid tasks which are given in different modes of representations: text, diagram of three dimensional cube of array and net diagram. In this end, section two presents the theoretical background, including a discussion on the relationship between motivational beliefs, metacognitive strategies and mathematics performance, and a brief review of students understanding of three dimensional rectangular arrays of cubes. Section three gives information about the sample of the study, the test used and the analysis employed. The results are presented in section four and section five discusses these results.

Theoretical background

Motivational beliefs, metacognitive strategies and mathematics performance

The affective domain has in recent years attracted much attention from mathematics research community; empirical data seem to increasingly support experts' opinion that affect plays a decisive role in the process of cognitive development (Philippou & Christou, 2002). Except that, the National Council of Teachers of Mathematics (1989) stressed the necessity to create educational goals which connect with affective domain: interesting, confidence and understanding of the meaning of mathematics. Also, indicated from the same organization the necessity to examine cognitive and affective variables during the analysis of teaching.

Motivational beliefs: task value, goal orientation and self-efficacy, are a part of affective domain that play an essential role in students classroom learning and achievement. Task value beliefs refer to students' evaluation about the usefulness and importance of the task (Eccles & Wigfield, 1995). Goal orientation refers to students reasons adopted when they engage in academic tasks (Pintrich & Schunk, 1996). Students' perceived self-efficacy for a task, are defined as their judgments about their ability to complete a task successfully (Bandura, 1997).

A number of studies have found a positive relationship between students' motivational beliefs, especially students' self-efficacy beliefs and mathematics performance (Pajares, 1996). More specifically, Pajares and Miller (1994) reported that self-efficacy in solving math problems was more predictive of that performance than sex, math background,

Students' motivational beliefs and the ability to solve volume problems

math anxiety, math self-concept and perceived usefulness of mathematics. Additionally to this, Pajares and Kranzler (1995) found that self-efficacy made as strong a contribution to the prediction of problem-solving as did general mental ability, an acknowledged powerful predictor and determinant of academic outcomes. In this line, Mayer (1998) stressed that students who improve their self efficacy will improve their success in learning to solve problems.

Researchers have also indicated that high-ability students have stronger self-efficacy and have more accurate self-perceptions (e.g. Pajares & Kranzler, 1995; Zimmerman, Bandura, & Martinez-Pons, 1992). Schunk and Hanson (1985) found that students who expected to be able to learn how to solve the problems tended to learn more than students who expected to have difficulty. In other words, students understand mathematics better when they have high self-efficacy than when they have low self-efficacy.

Also, students' motivational beliefs correlate with metacognitive strategies use. Researchers found a positive relation between students' valuing of academic tasks and their use of metacognitive strategies (Pintrich & DeGroot, 1990; Wolters & Pintrich, 1998). Especially, Wolters and Pintrich (1998), found that middle school students who expressed greater valuing of the material in a subject area were more likely to also report using self-regulatory strategies (a kind of metacognitive strategies) with regard to that subject area. Wolters, Yu, and Pintrich (1996) found that students' having a learning goal orientation predicted their self-reported use of both cognitive and self-regulatory strategies in mathematics. Pintrich and De Groot (1990) found strong correlations between students' self-efficacy and their use of active learning strategies in various classes.

Motivational beliefs, especially self-efficacy beliefs have already been studied in relation to a lot of aspects of mathematics learning, such as arithmetical operations, problem solving and problem posing (Nicolau & Philippou, 2007). However, these beliefs haven't been examined in relation to volume measurement tasks and this study tries to investigate these relationships.

Students understanding of three dimensional rectangular arrays of cubes

The ability to understand and manipulate three dimensional figures is very important in mathematics education. Mitchelmore (1980) stressed that it is of great value to be able to visualize and represent three dimensional configurations and to comprehend the geometrical relations among various parts of a figure. Although, Mariotti (1989) hypothesized that the manipulation of three dimensional figures implies coordination of a comprehensive mental representation of the object with the analysis of the single components.

A number of researchers studied students understanding of three dimensional rectangular arrays of cubes, using interviews or test (Ben – Chaim, Lappan & Houang, 1985, 1989; Battista & Clements, 1996; Battista, 1999). In particular, Ben – Chaim et al. (1985) indicated four types of errors that students in grades 5-8 made on the volume

measurement tasks with three dimensional cube array. The first error was the estimate the number of faces of cubes shown in a given diagram, while the second error was identified from doubling that number. The third error was counting the number of cubes shown in the diagram and the fourth error was doubling that number. In this study, researchers asked students to determine how many cubes it would take to build such prisms and they found that only 46% of students gave correct answer, while most of them made the errors of type 1 or 2 (Ben-Chaim et al., 1985). These results indicated from a recent work of Battista and Clements (1996) where they found that 64% of the third graders and 21% of the fifth graders double-counted cubes. These types of errors students made are clearly related, according to Ben-Chaim et al. (1985), to some aspects of spatial visualization. Addition on this explanation, Battista and Clements (1996) stressed that many students are unable to correctly enumerate the cubes in such an array, because their spatial structuring of the array is incorrect. In particular, they found that for some students the root of such errant spatial structuring seemed to be their inability to coordinate and integrate the views of an array to form a single coherent mental model of the array. However, Hirstein (1981) believes that these errors caused from confusion between volume and surface area.

The present study

The purpose of the study

This study has two main objectives. First, we set out to explore the relationships between students' motivational beliefs, metacognitive strategies use and volume measurement performance. Second, we examined the solutions strategies and errors of students in dealing with three dimensional cube arrays and net diagram. More specifically, the present study addresses the following questions: (a) Are there differences at performance of students on verbal problems, problems with 3-D cube array diagram and problems with net diagram?, (b) What are the relationships between motivational beliefs, metacognitive strategies use and volume measurement performance? (c) Can self efficacy beliefs and generally motivational beliefs be strong predictors of students' volume measurement of cuboids performance? (d) Are there differences at self-efficacy beliefs between students of varied abilities? (e) Which strategies did students use to calculate the volume of cuboids in problems with different modes of representations?

Sample

In the present study data was collected from 173 sixth grade students (84 females and 89 males) ranging from 11 to 11.5 years old. These students were from 10 primary schools in Cyprus from rural and urban areas.

Test

All participants completed a two part test in a period of 40 minutes in March 2008. The first part was a self-report questionnaire which assesses the three types of *motivational beliefs* (MB): *self efficacy beliefs* (SE) (e.g. "I am very good in 3-D geometry", "Compared with others students in this class, I think I am a good student in

Students' motivational beliefs and the ability to solve volume problems

mathematics”), *task value beliefs* (TV) (e.g. “I like 3-D tasks that I’ll learn from, even if I make a lot of mistakes”, “I like math problems best when it really makes me think”), *goal orientation* (GO) (e.g. “I would feel really good if I were the only one who could answer the teacher’s questions in math class”), the *metacognitive strategies use* (S) (e.g. “Before I begin solving a mathematical problem, I often decide how to organize its solution”, “When I don’t understand a mathematical problem, I read it again”), the *self-representation of spatial ability* (SA) (e.g. “I can easily imagine the picture which is on a deflated balloon”, “I find it difficult to imagine how a three-dimensional geometric figure would exactly look like when rotated”) and the *preference of students for the use of representations in problem solving* (R) (e.g. “I prefer solving problems that present the data with diagrams or tables”, “In order to explain an idea to my classmates I use a picture or a diagram”). This 22-item questionnaire was based on the MSLQ questionnaire (see Pintrich, Smith, Garcia & McKeachie, 1993) and the Patterns of Adaptive Learning Survey (PALS; see Middleton & Midgley, 2002) to measure motivational beliefs and metacognitive strategies use. Items from OSIQ questionnaire used to measure the self-representation of spatial ability (see Blajenkova, Kozhevnikov & Motes, 2006) and measures of the preferences for the use of representations taken from the questionnaire of the study of Panaoura (2007). Responses were recorded on a 4 point Likert scale with 1 indicating total disagreement and 4 total agreement. Ratings 2 to 3 indicated intermediate degrees of agreement/disagreement. The second part of the test was six volume measurement tasks which were given in different modes of representations: text, diagram of 3-D cube array and net diagram (see table 1).

Table 1: Volume Measurement Tasks.

MODE OF REPRESENTATIONS	TASKS
Verbal tasks	<p>1. Mary tries to put 28 unit-sided cubes (1 cm edge) in a rectangular box with dimensions 2 cm x 5 cm x 3 cm. Is this possible? Explain your answer. (VPr1)</p> <p>4. Four friends went to the cinema. They decided to buy some bags of nuts during the movie. The vendor said to them that there were two size bags of nuts, where:</p> <ul style="list-style-type: none"> • The price of small bag was €1. • The large bag’s dimensions were two times the small bag’s dimensions and its price was €6. <p>The dimensions of the small bag were 20 cm, 10 cm and 5 cm.</p> <p>One child suggested to his friends that it was better to buy and share one large size bag, instead of buying four small bags. Do you agree? Explain your answer. (VPr4)</p>

Tasks with diagram of three dimensional cube array

Find the volume (the number of cubes) of the following cuboids:

2a.

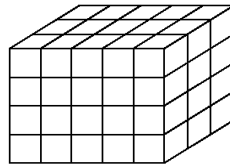

(SPr2a)

2b.

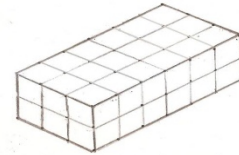

(SPr2b)

Which one of these cuboids has the greatest number of cubes? Explain your answer. (SPr2Ans)

Tasks with net diagram

The figures below show the nets of cuboids with on its sides missing. Find the volume (number of cubes) of these nets when folded:

3α.

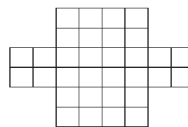

(NPr3a)

3β.

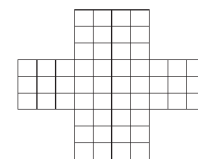

(NPr3b)

Which one of these nets when folded can carry the minimum number of cubes? Explain your answer. (NPr3Ans)

Firstly, students completed the self-report questionnaire and then they solved the tasks, because according to Bandura (1997), the time between these two measures must be short.

The coefficient of reliability Gronbach's Alpha of the two part of test was very high. Specifically, we found that the reliability of students' answers in the questionnaire was $\alpha=0.746$ and the reliability of their answers in volume measurement tasks was $\alpha=0.810$.

Data analysis

Students correct responses in volume measurement tasks were marked with 1 and the incorrect response with 0. However, the marks to the responses in the questions "Which one of these cuboids has the greatest number of cubes? Explain your answer" and "Which one of these nets when folded can carry the minimum number of cubes? Explain your answer" were 1 to fully correct response, 0.5 to partly correct response (wrong explanation) and 0 to incorrect answer. To examine the strategies students use to

Students' motivational beliefs and the ability to solve volume problems

find the volume in 3-D cube array diagram and net diagram, categories from previous studies (Ben Chaim et al., 1985; Battista & Clements, 1996) were used.

To explore the relationships between motivational beliefs, metacognitive strategies and volume measurement performance, we employed regression analysis, Pearson correlation and one way ANOVA. Gras's Implicative Statistical Model (Bodin, Coutourier & Gras, 2000) was used to examine the performance of students in volume measurement tasks in different modes of representations. It is a method of analysis that determines the similarity connections and the implicative relations of factors. Finally, descriptive statistics were used to present the strategies students use to find the volume in 3-D cube array diagram and net diagram.

Results

The section of results has two parts. In the first part we examined the relationships between motivational beliefs, metacognitive strategies use and volume measurement performance and in the second part we described the strategies students use to volume measurement tasks in different modes of representations.

Relationships between motivational beliefs, metacognitive strategies use and volume measurement performance

Firstly, we presented the students' performance in volume measurement tasks. According to table 2, a large number of students gave correct answer to the question of task 2 where 54, 3% of students indicated correctly the 3-D cube array diagram which has the greatest number of cubes.

Table 2: The means and the standard deviations of students' performance in volume measurement tasks.

Tasks	Mean (\bar{X})	Standard deviation (SD)
Verbal task 1	0,529	0,460
Task 2a with 3-D cube array diagram	0,301	0,460
Task 2b with 3-D cube array diagram	0,289	0,455
Task 2 answer	0,543	0,323
Task 3a with net diagram	0,156	0,364
Task 3b with net diagram	0,145	0,353
Task 3 answer	0,356	0,336
Verbal task 4	0,307	0,368

N = 173

However, only 30% of students gave the correct number of cubes of cuboids which given in 3-D cube array diagrams (tasks 2a and 2b). At verbal tasks, 52,9 % of students explained correct that 28 unit-sided cubes can be placed in a rectangular box with dimensions 2 cm x 5 cm x 3 cm (task 1) and 30, 7% of students gave correct answer to task 4. Also, only 15% of students counted correct the number of cubes (tasks 3a and

3b) of nets folded and 37% of them indicated the cuboid which has the minimum number of cubes. These tasks require from students to imagine in their minds the cuboids created when the given nets are folded and count their volume. It is a very complex mental procedure (Mariotti, 1989) and that is why many of the students gave wrong responses.

We used the Gras model to determine the similarity connections of students' responses to volume measurement tasks which were given in different modes of representations. The similarity diagram (figure 1) identified a cluster which has all tasks of test. The way to solve verbal volume measurement tasks are statistically similar to the way to solve the tasks with 3-D cube array diagram and net diagram. But figure 1 shows that the verbal tasks grouped in a different cluster from other tasks.

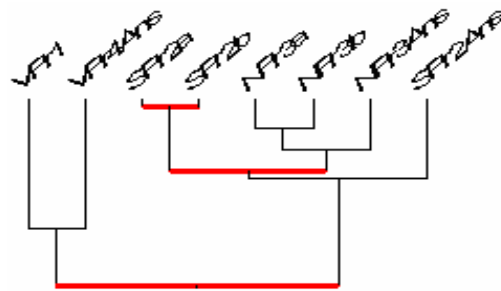

Figure 1. Similarity diagram of students' responses to volume measurement tasks in different representations.

Using Pearson correlation, we examined the relations between the factors: Self-Efficacy, Motivational Beliefs, Self-representation of Spatial Ability, Metacognitive Strategies use and preference for the use of representation in problem solving. We found that there are statistically significant correlations between students' self-efficacy beliefs to solve mathematics problems generally and volume measurement problems specifically, and metacognitive strategies use, preference for the use of representation and self-representation of spatial ability (see table 3).

Table 3: Coefficients Correlations between the factors SE, MB, SA, S, R.

	Self-Efficacy Beliefs	Motivational Beliefs
Self - representation of spatial ability	0.32*	0.38*
Metacognitive strategies use	0.26*	0.50*
Preference for the use representations in problem solving	0.17*	0.34*

* $p < 0.05$, $N = 173$

In other words, students which have high self-efficacy beliefs, they stated more than others that they used often metacognitive strategies to solve a mathematical problem,

Students' motivational beliefs and the ability to solve volume problems

they preferred to use representation in problem solving and they had high spatial abilities. Also, we found statistically significant correlations between students' motivational beliefs and other factors (see table 3). Specifically, students who are more highly motivated, they stated more than others that they use metacognitive strategies, they have high spatial abilities and they preferred to use representations in problem solving.

We used regression analysis with independent variables students' self-efficacy beliefs and students' motivational beliefs and dependent variable the general volume measurement performance at test. According to table 4, students' self-efficacy beliefs and students' motivational beliefs can be statistically significant predictors of general volume measurement performance. Specifically, students' self-efficacy beliefs predicted 14,2 % of the general volume measurement performance, while students' motivational beliefs predicted only 3% of the general volume measurement performance.

Table 4: Regression analysis of Self-efficacy beliefs and Motivational beliefs with dependent variable total achievement.

Independent Variables	R	R ²	F	B
Self-Efficacy beliefs	0.38	0.142	28.200*	0.977*
Motivational beliefs	0.172	0.03	5.202*	0.529*

*p<0.05

To examine the predictive role of students' self-efficacy beliefs, motivational beliefs, self-representation of spatial ability and preference for the use of representations in problem solving to verbal volume measurement tasks performance, volume measurement tasks with 3-D cube array diagram performance and volume measurement tasks with net diagram performance, regression analysis used. We found that students' self-efficacy beliefs can be a statistically significant predictor of volume measurement performance in every task, expert the performance at task 2a (see table 5). Students' motivational beliefs can be a statistically significant predictor of volume measurement performance only at verbal tasks (3%) and at task 2Ans (3%), where students indicated the cuboid which has the greatest number of cubes. The factor of self-representation of spatial ability predicted only the performance at verbal task 1 and specifically 5% of that. The verbal task 1 required from students to imagine a rectangular box with given dimensions and 28 one sided cubes to put in that box. Spatial abilities such as mental rotation of figure and spatial relations of cubes in the box, were necessary to successful performance at that task. Also, metacognitive strategies use can be a statistically significant predictor of the volume measurement performance at verbal tasks only (3%). The factor of metacognitive strategies was used to refer to students' strategies in problem solving which were given in text form. That is probably the reason for the predictive role of metacognitive strategies to the verbal tasks performance only.

Table 5: Regression Analysis of SE, MB, SA, S with dependent variables the performance on tasks.

Dependent Variables		Independent Variables	R	R ²	F	β
Verbal task 1 performance		Self-Efficacy beliefs	0.320	0.102	19.475*	0.239*
		Motivational beliefs	0.176	0.031	5.489*	0.156*
		Self-representation of spatial ability	0.221	0.049	8.778*	0.175*
		Metacognitive strategies use	0.160	0.026	4.499*	0.128*
Task 2 with 3-D cube array diagram performance	b	Self-Efficacy beliefs	0.198	0.039	6.740	0.163
	Ans	Self-Efficacy Beliefs	0.216	0.047	8.059*	0.125*
		Motivational beliefs	0.172	0.030	5.244*	0.107*
Task 3 with net diagram performance	A	Self-Efficacy beliefs	0.197	0.039	6.674*	0.129*
	B	Self-Efficacy beliefs	0.179	0.032	5.462*	0.114*
	Ans	Self-Efficacy beliefs	0.250	0.063	11.044*	0.151*
Verbal task 4 Performance		Self-Efficacy beliefs	0.369	0.136	25.790*	0.243*
		Motivational beliefs	0.197	0.039	6.837*	0.139*
		Metacognitive Strategies use	0.194	0.038	6.662*	0.124*

*p<0.05

The sample of this study was clustered into three groups according to their volume measurement performance at tasks of the second part of the test. Specifically, the first group had the students with the lowest performance, the second group had the students with medium performance and the third group had the students with highest performance. The performance of the three clusters of students was examined in respect to their students' self-efficacy beliefs. The comparison of the means by one way ANOVA indicated statistically significant differences between these groups ($F_{(2,163)}=8.155, p=0.000$) at self-efficacy beliefs. Using Bonferroni procedure, we found only statistically significant differences of self-efficacy beliefs between students with

Students' motivational beliefs and the ability to solve volume problems

the lowest performance ($\bar{X} = 3.0182$) and highest performance ($\bar{X} = 3.5490$) at volume measurement tasks.

Also, the students were divided into three groups according to their self-efficacy beliefs. The first group had the students with low self-efficacy beliefs, the second group had the students with medium self-efficacy beliefs and the third group had the students with high self-efficacy beliefs. The self-efficacy of the three clusters of students was examined in respect to their general volume measurement performance. The comparison of the means by one way ANOVA indicated statistically significant differences between these groups ($F_{(2,163)}=8.257$, $p=0.000$) at volume measurement performance. Using Bonferroni procedure, students with high self-efficacy beliefs ($\bar{X} = 2.1747$) and students with medium self-efficacy beliefs ($\bar{X} = 1.2177$) differed significantly in their general volume measurement performance.

Strategies students use to volume measurement tasks

The second aim of this study was to examine the solutions, strategies and errors of students in dealing with three dimensional cube arrays and net diagram. To examine this, the types of errors from previous studies (Ben – Chaim et al., 1985; Battista & Clements, 1996) were used. We found that only fifty two students in the task 2a and forty nine students in the task 2b, counted correctly the number of cubes of cuboids (which given in 3-D cube array diagram). Also, according to table 6, many of the students who gave wrong answers, counted the number of faces of cubes shown in the 3-D cube array diagram and doubled that number or used other wrong strategy which can't be categorized. Thirteen students in the task 2a and fourteen students in the task 2b, counted the number of faces of cubes shown in 3-D cube array diagram and gave wrong answer.

Table 6: Students Strategies use to volume measurement tasks with 3-D cube array diagram.

Students Strategies use	Number of students	
	2a	2b
Correct answer	52	49
Count the number of faces of cubes shown in the 3-D cube array diagram	13	14
Count the number of faces of cubes shown in the 3-D cube array diagram and double that number	48	58
Other wrong strategy	42	31
No answer	18	21

In the question “Which of cuboids (given in the 3-D cube array diagram) has the greatest number of cubes?”, ninety five students answered correctly counting the volume of cuboids, while thirty seven students gave correct answer using their “optic feeling”. In some words, these students compared the two 3-D cube array diagrams without counted the number of cubes of cuboids and gave their answer.

Table 7, shows students’ strategies use to volume measurement tasks with net diagram. Many of students gave wrong responses or didn’t answer those tasks. Fifty seven students in the task 3a and fifty three students in the task 3b, counted the number of faces of cubes in net diagram and gave wrong answers. Also, twenty one students in the task 3a and twenty in the task 3b, counted the number of faces of cubes shown in net diagram and added the number of faces of cubes of base. A small number of students counted the number of faces of cubes shown in net diagram and doubled that number (see table 7).

Table 7: Students Strategies use to volume measurement tasks with net diagram.

Students Strategies use	Number of students	
	3a	3b
Correct answer	27	25
Count the number of faces of cubes shown in net diagram	57	53
Count the number of faces of cubes shown in net diagram plus the number of faces of cubes of base	21	20
Count the number of faces of cubes shown in net diagram and double that number	13	15
Other wrong strategy	7	13
No answer	48	47

In the question “Which of the given nets when folded can carry the minimum number of cubes?”, forty six students gave correct response counting the volume of cuboids from net diagram, while forty four students answered correctly using their “optic feeling”. In some words, these students compared the two net diagrams without counting the number of cubes of cuboids and gave their answer.

Discussion

The first aim of the present study was to investigate the relationships between students’ motivational beliefs, metacognitive strategies use and volume measurement performance. We found statistically significant correlations between students’ motivational beliefs and students’ self-efficacy beliefs especially, and metacognitive strategies use. Previous studies confirm these findings (Pintrich & De Groot, 1990; Pintrich, 1999). Specifically, students with strong self-efficacy beliefs, goal orientation

and high task value, employ different kinds of cognitive and metacognitive learning strategies more actively (Pintrich, 1999).

Also, we found that students' self-efficacy beliefs was a strong predictor of the general volume measurement performance and the volume measurement performance in every task. The predictive role of self-efficacy beliefs was indicated from various studies in different concepts of mathematics (Pajares & Miller, 1994; Pajares & Kranzler, 1995; Mousoulides & Philippou, 2005; Nicolaou & Philippou, 2007). Specifically, we found that the confidence with which students approach maths problem solving and volume measurement problems had stronger direct effects on their volume measurement performance than did their self-representation of spatial ability, metacognitive strategies use and preference for the use of representation in problem solving.

On the contrary, we found that students' metacognitive strategies predicted only the performance on the verbal volume measurement tasks. We particularly expected to find a positive relationship between volume measurement performance and students' metacognitive strategies. A possible reason for this may be the fact that students used metacognitive strategies in mathematical problems which were given in text form and maybe they didn't know how to use them in the tasks with diagram of 3-D cube array or net diagram. They probably considered that these tasks with the diagram of 3-D cube array or net diagram were not mathematical problems.

Additionally, we found that students' self-representation of spatial ability was a statistically significant predictor of the performance on the verbal task where students were asked to make a decision: 28 one sided cubes can be placed in a rectangular box with given dimensions. The task was not simple and required high spatial abilities (mental rotation and spatial relations).

We found statistically significant differences of self-efficacy beliefs between students with high-ability (high volume measurement performance) and students with low ability (low volume measurement performance). This finding is in agreement with other researchers' findings (e.g. Pajares & Kranzler, 1995; Zimmerman, Bandura, & Martinez-Pons, 1992) who found that high-ability students have stronger self-efficacy and have more accurate self-perceptions. Also, we found statistically significant differences at volume measurement performance between students with high self-efficacy and medium self-efficacy. Specifically, students who have high self-efficacy understand the volume measurement tasks better than the students who have medium self-efficacy. The study of Schunk and Hanson (1985) confirmed this finding.

The second aim of this study was to examine the strategies students use to volume measurement tasks in different modes of representations. We found that many of the students gave wrong answer using the two strategies in the main: (a) count the number of faces of cubes shown in diagram (net or 3-D cube array) and (b) count the number of faces of cubes shown in diagram (net or 3-D cube array) and double that number. These strategies were also used by many of the students of the sample of the study of Ben-Chaim et al. (1985). A number of students of the research of Battista and Clements (1996) used the strategy b. These errors are caused, according to Gutiérrez (1996), from

the difficulty of reasoning of flat representations of three dimensional figures to three dimensional figures because some information are lost. Hirstein (1981) stressed that students confuse the concepts of the volume and the surface area. Battista and Clements (1996) claimed that students' spatial structuring of the array is incorrect. Specifically, the mental procedure which is required in that task is very complex (Mariotti, 1989) because students must be able to coordinate and integrate the views of an array to a single coherent mental model of the array (Battista & Clements, 1996).

In conclusion, the findings of the present study suggest that developing efficacy beliefs in mathematical problems generally, should be an integral part of mathematics teaching and learning.

References

- Bandura, A. (1997). *Self– Efficacy: The exercise of control*. New York: Freeman.
- Battista, M.T. (1999). Fifth graders' enumeration of cubes in 3D arrays: Conceptual progress in an inquiry - based classroom. *Journal for Research in Mathematics Education*, 30 (4), 417 - 448.
- Battista, M.T. & Clements, D.H. (1996). Students' understanding of three-dimensional rectangular arrays of cubes. *Journal for Research in Mathematics Education*, 27 (3), 258 -292.
- Ben-Chaim, D., Lappan, G., & Houang R.T. (1985). Visualizing rectangular solids made of small cubes: Analyzing and effecting students' performance. *Educational Studies in Mathematics*, 16, 389 – 409.
- Ben-Chaim, D., Lappan, G., & Houang R.T. (1989). Adolescents' ability to communicate information: Analyzing and effective students' performance. *Educational Studies in Mathematics*, 20(2), 121-146.
- Blajenkova, O., Kozhevnikov, M., & Motes, M. A. (2006). Object-Spatial Imagery: A New Self-Report Imagery Questionnaire. *Applied Cognitive Psychology*, 20, 239-263.
- Bodin, A., Coutourier, R. and Gras, R.: 2000, *CHIC : Classification Hiérarchique Implicative et Cohésive-Version sous Windows – CHIC 1.2*, Association pour la Recherche en Didactique des Mathématiques Rennes.
- Eccles, J., & Wigfield, A. (1995). In the mind of the actor: The structure of adolescents' achievement task values and expectancy-related beliefs. *Personality and Social Psychology Bulletin*, 21, 215-225.
- Gutiérrez, A. (1996). Children's ability for using different plane representations of space figure. In A.R. Batturo, (Ed.), *New directions in geometry education* (pp. 33-42). Centre for Math. and Sc. Education, Q.U.T.: Brisbane, Australia

- Hirstein, J.J.(1981). The second national assessment in mathematics: Area and volume. *Mathematics and Teacher*, 74, 704 – 708.
- Ma, X. & Kishor, N. (1997). Assessing the relationship between attitude toward mathematics and achievement in mathematics: a meta - analysis. *Journal for research in mathematics education*, 28(1), 26-47.
- Mayer, R.E. (1998). Cognitive, metacognitive, and motivational aspects of problem solving. *Instructional Science*, 26, 49-63.
- Mariotti, M. A. (1989). Mental images: some problems related to the development of solids. *Actes de la 13 conference internationale, psychology of mathematics education* (Vol. 2). Paris (France).
- Middleton, M.J. & Midgley, C. (2002). Beyond Motivation: Middle school students' perceptions of press for understanding in math. *Contemporary Educational Psychology*, 27, 373-391.
- Mousoulides, N. & Philippou, G. (2005). Students' motivational beliefs, self-regulation strategies and mathematics achievement. In H.L. Chick, & J.L. Vincent (Eds.), *Proceedings of the 29th Conference of the International Group for the Psychology of Mathematics Education* (Vol. 3, pp. 321 - 328). Melbourne: PME.
- Nicolaou, A.A. & Philippou, G.N. (2007). Efficacy beliefs, problem posing, and mathematics achievement. In D. Pitta-Pantazi, & G. Philippou (Eds.), *Proceedings of the V Congress of the European Society for Research in Mathematics Education* (pp. 308 – 317). Larnaca, Cyprus: Department of Education, University of Cyprus.
- NCTM. (1989). *Curriculum and evaluation standards for school mathematics*. Reston, VA: The Council.
- Pajares, F. (1996). Self-Efficacy beliefs and mathematical problem-solving of gifted students. *Contemporary Educational Psychology*, 21, 325-344.
- Pajares, F. & Kranzler, J. (1995). Self – efficacy beliefs and general mental ability in mathematical problem solving. *Contemporary Educational Psychology*, 20, 426 – 443.
- Pajares, F. & Miller, M. D. (1994). Role of self-efficacy and self-concept beliefs in mathematical problem solving: A path analysis. *Journal of Educational Psychology*, 86 (2), 193 – 203.
- Panaoura, A. (2007). The impact of recent metacognitive experiences on preservice teachers' self – representation in mathematics and its teaching. In D. Pitta-Pantazi, & G. Philippou (Eds.), *Proceedings of the V Congress of the European Society for Research in Mathematics Education* (pp. 329 – 338). Larnaca, Cyprus: Department of Education, University of Cyprus.
- Patterson, N. & Norwood, K. (2004). A case study of teacher beliefs in students' beliefs about multiple representations. *International Journal of Science and Mathematics Education*, 2 (1), 5 – 23.

- Pintrich, P.R. (1999) The role of motivation in promoting and sustaining self – regulated learning. *International Journal of Educational Research*, 31, 459 – 470.
- Pintrich, P.R. & De Groot, E. (1990). Motivational and self-regulated learning components of classroom academic performance. *Journal of Educational Psychology*, 82 (1), 33-50.
- Pintrich, P. R. & Schrauben, B. (1992). Students' motivational beliefs and their cognitive engagement in classroom tasks. In D. Schunk, & J. Meece (Eds.), *Student perceptions in the classroom: Causes and consequences* (pp. 149-183). Hillsdale, NJ: Lawrence Erlbaum Associates.
- Pintrich, P. & Schunk, D. (1996). *Motivation in education: Theory, research, and applications*. Englewood Cliffs, NJ: Prentice-Hall.
- Pintrich, P., Smith, D.A.F., Garcia, T., & McKeachie, W.J. (1993). Reliability and predictive validity of the motivated strategies for learning questionnaire (MSLQ). *Educational and Psychological Measurement*, 53, 801-813.
- Philippou, G. & Christou, C. (2002). A study of the mathematics teaching efficacy beliefs of primary teachers. In G.C. Leder, E. Pehkonen, & G. Törner (Eds.), *Beliefs: A hidden Variable in Mathematics Education?* (pp. 211-231). Netherlands: Kluwer Academic Publishers.
- Philippou, G. & Christou, C. (2001). *Educational texts: Affective factors and mathematics learning* (Κείμενα Παιδείας: Συναισθηματικοί Παράγοντες και μάθηση των Μαθηματικών). Athens: Atrapos Publishers.
- Schunk, D.H. & Hanson, A.R. (1985). Peer models: Influences on children's self-efficacy and achievement. *Journal of Educational Psychology*, 77, 313–322.
- Weiner, B. (1990). History of motivational research in education. *Journal of Educational Psychology*, 82(4), 616-622.
- Wolters, C.A. & Pintrich, P.R. (1998). Contextual differences in student motivation and self-regulated learning in mathematics, English, and social studies classrooms. *Instructional Science*, 26, 27-47.
- Wolters, C.A. & Rosenthal, H. (2000). The relation between students' motivational beliefs and their use of motivational regulation strategies. *International Journal of Educational Research*, 33, 801-820.
- Wolters, C., Yu, S., & Pintrich, P. (1996). The relation between goal orientation and students' motivational beliefs and self-regulated learning. *Learning and Individual Differences*, 8, 211-238.
- Zimmerman, B.J., Bandura, A., & Martinez-Pons, M. (1992). Self-motivation for academic attainments. The role of self-efficacy beliefs and personal goal setting. *American Educational Research Journal*, 29, 663-676.



Investigating the structures of students' geometrical performance

Georgia Panaoura & Athanasios Gagatsis
Department of Education, University of Cyprus

Abstract

The present study examined the structure of primary (grades 4 and 6) and secondary (grade 8) students' geometrical knowledge and abilities referring to tasks involving different geometrical figures. Based on the assumption that students' ability to solve tasks involving different geometrical figures is not a unitary construct, we developed in the structural equation modelling a framework to investigate its subcomponents. Confirmatory factor analysis affirmed the existence of three constructs of this geometrical ability: (a) students' ability to work with tasks involving 2D geometrical figures, (b) the ability to work with tasks involving 3D geometrical figures and (c) the ability to work with net-representations of 3D geometrical figures. Multiple group analysis results supported the invariance of this structure across the three age groups of students.

Introduction

The study of geometry helps students represent and make sense of both the world in which they live and the world of mathematics. The importance of studying and teaching geometry is well established in the literature and is stressed in contemporary mathematics curricula, not only as an autonomous mathematics field, but also as a means to develop other mathematical concepts. As Duval (1998) has noted, geometry can be used to discover and develop different ways of thinking. The content of geometry can be used to develop lower mathematical reasoning, such as recognizing figures, and higher mathematical reasoning, such as discovering the properties of figures, inventing geometrical patterns, or solving problems (NCTM, 1989). Additionally, geometric ideas are useful in representing and solving problems in other areas of mathematics as well as in real-world situations (NCTM, 2000).

During the past twenty years, several mathematics educators have investigated students' geometrical reasoning based on different theoretical frames, such as Van Hiele's model referring to levels of geometric thinking (Van Hiele, 1986), Fischbein's theory of figural concepts (Fischbein, 1993), Duval's cognitive analysis of geometrical thinking (Duval, 1998). Considering the importance of geometrical reasoning in mathematics education, there is a need for a framework of abilities that could be used in fostering students' geometrical performance. Although there are many studies on different aspects of geometrical reasoning, in the literature, there are no structural models describing the

way students' experiences arising from geometry teaching at school are built into meaningful structures. This is what the present study aims to do.

Theoretical considerations

Geometry consists of ways of structuring space (for example, when we conceptualize it in terms of lines, angles, polygons, and polyhedra) and analyzing the consequences of that structuring (Battista, 1999). As a mathematical domain, geometry is to a large extent concerned with specific mental entities, the geometrical figures. Through the study of geometry, students learn "about geometrical shapes and structures and how to analyze their characteristics and relationships" (NCTM, 2000, p. 41).

Teaching geometry so that students learn it meaningfully requires an understanding of how students construct their knowledge of various geometric topics (Battista, 1999). This means it is necessary that mathematics educators investigate and mathematics teachers understand how students construct knowledge as a result of their learning experiences in school.

The problem of how mathematical knowledge is acquired and understood and how the mathematical structure is built have been described and studied from several points of view. Sfard's theory of reification (Sfard, 1989), Sierpinska's theory of understanding (Sierpinska, 1994), the suggestion of procepts (Gray & Tall, 1994) are some examples that illustrate this effort. It is generally accepted that students acquire, as a result of the experiences they have during their geometry education, pieces of geometrical knowledge, which are initially stored as isolated events, or images (Hejny, 2002). The obtained isolated models of a creating piece of knowledge are later organized, and put into hierarchies to create a structure (Hejny, 2003).

Demetriou's model (Demetriou, 1998; Demetriou, 2004; Demetriou & Kazi, 2001) about the dynamic organization and development of mind postulates that the mind involves systems oriented to the understanding of the environment and of itself, in addition to general processing functions. The development of each of the systems involves both system-specific and system-wide mechanisms of development and learning. The idea about a hierarchical and multisystem mind which involves structures that deal with different types of problems in the environment suggests that learning may be either domain-specific or domain-free. Domain-specific or modular learning springs from particular domains in the environment and it affects the functioning of the corresponding domain-specific modules. Using Demetriou's model about the architecture of mind as a "departure point framework", we consider the set of geometrical abilities developed by an individual as a specific domain which deals with its own types of problems and, we investigate students' geometrical knowledge and abilities related to tasks involving different geometrical figures.

The present study

The present study was based on the assumption that students' geometrical knowledge and abilities related to tasks involving different geometrical figures is a multifaceted

construct, with subcomponents which are probably related to the students learning experiences in geometry lessons throughout their schooling years. Therefore, the main purpose of the study was to propose and validate a framework which describes the components of students' (age 10, 12 and 14) abilities to solve tasks involving different geometrical figures and to investigate its factorial structure across students of three different grades.

We know that primary school students acquire, through geometry teaching at school, knowledge referring to two-dimensional and three-dimensional geometrical figures, as well as the net-representations of geometrical solids. What we do not know is whether and how these pieces of knowledge are connected or related to each other. As mentioned earlier, the major aim of this study was to prescribe a framework of students' geometrical knowledge and abilities related to tasks involving different geometrical figures. In other words, examining the knowledge base that students acquire through their learning experiences in geometry lessons during their primary school years, we investigated to what extent and how various pieces of geometrical knowledge referring to different geometrical figures are built into meaningful structures.

In the present study, we initially focused on the geometrical knowledge and abilities related to tasks involving different geometrical figures of students at the end of primary school (6th graders), just before entering the secondary school. Considering that students in Cyprus experience difficulties which are evident in their mathematics performance during the transition from elementary to secondary school (Meletiou-Mavrotheris & Stylianou, 2003), we sought to compare the aforementioned geometrical knowledge and abilities structure of the 6th graders with the corresponding one of secondary school students. So, finally we chose to gather data from three different school grades: students terminating primary school education (6th graders – age 12), primary school students in grade 4 (age 10) and students which have been in secondary school for two years (8th graders – age 14). Apart from suiting our aim of comparing the geometrical structures of students from two educational levels, the choice of the three age groups participating in our study, was based on the idea that changes in the cognitive system of children between the age of 10 and 14 are of major importance (Demetriou, Christou, Platsidou, & Spanoudis, 2002).

Method

Participants

Participants were 1000 primary and secondary school students (488 males and 512 females) from 29 existing classes of 9 elementary schools and 12 classes of 8 secondary schools in four different districts of Cyprus. Specifically, the sample involved students from three grades (fourth grade – primary school: 332, sixth grade – primary school: 333 and, eighth grade – second grade of secondary school: 335). The mean age of the three grades was as follows: fourth grade, 9.8 years; sixth grade, 11.7 years; eighth grade, 13.9 years. The school sample is representative of a broad spectrum of

socioeconomic backgrounds. In each intact class there were students of different levels of achievement.

Instrument and Procedure

Geometrical performance in tasks involving different geometrical figures was determined using a test that was constructed for the purpose of the present study. One of the requirements for the development of the test was its alignment with the national curriculum followed in Cyprus in all primary schools. A content analysis of the curriculum and the textbooks employed in the three upper primary grades (grade 4 to grade 6) was undertaken. The analysis revealed that tasks involving 2D geometrical figures occupy a predominant place both in the curriculum and the mathematics textbooks.

In the construction of the test we took into consideration Duval's framework analyzing geometrical thinking (Duval, 1998) and therefore included in the test a number of tasks involving two cognitive processes described in his framework, naming 'visualization' and 'reasoning'. Additionally, for the tasks involving 2D figures, we used items that could be solved either based on visual perception indicating students working in the Natural Geometry paradigm, or based on the properties of figures indicating students working in the Natural Axiomatic Geometry paradigm (Houdement & Kuzniak, 2003).

The geometrical-figures performance test consisted of tasks involving 2D geometrical figures, 3D figures and nets of geometrical solids. The 2D geometrical figures tasks included recognition items in simple and complex geometrical figures, problem solving items which involved the use of geometrical reasoning to be solved, multiple choice items examining declarative knowledge of geometric concepts and properties of figures and items involving analysis of geometrical figures and area calculation. The 3D geometrical figures tasks included recognition items, multiple choice items referring to the faces or other properties of 3D figures, items demanding analysis of a three-dimensional figure to its consisting parts. The net-representations tasks included items referring to constructing and recognizing nets of a cube, items involving a net of a specific cube and its corresponding drawing and items referring to recognition of nets of other geometrical solids. Examples of the geometry items used can be found in the Appendix.

The items of the test were content and face validated by two experienced primary school teachers, two university tutors of Mathematics Education and, one university tutor of Cognitive Psychology. Based on their comments, minor revisions were made.

The test was administered in two parts during normal teaching, either by the first author or by students in Mathematics Education at the University of Cyprus, who followed specific instructions concerning the test administration. Administration time was 40 minutes per part. The first part of the test was administered to all schools in the same week, while the second part of the test was administered one week later.

Recognition items and multiple choice items were scored on a pass (1) / fail (0) basis. The problem solving items were scored using a scale from 0 to 2 as follows. No answer or a wrong answer was marked with 0. Complete right answers were marked with 2. In the cases that the students followed a correct solution process but gave a wrong answer, the item was marked with 1.

Statistical Analyses

With the use of the Extended Logistic Model of Rasch (Rasch, 1980), an interval scale presenting both item difficulties and students' performance was created for geometrical test. Data analysis revealed that the test had satisfactory psychometric properties, namely construct validity and reliability.

The assessment of the proposed model was based on a confirmatory factor analysis, which is part of a more general class of approaches called structural equation modeling. EQS computer software (Bentler, 1995) was used to test model fitting. In order to evaluate model fit, three fit indices were calculated by the maximum likelihood method (Bentler, 1995): the chi-square to its degrees of freedom ratio (χ^2/df), the comparative fit index (CFI), and the root mean-square error of approximation (RMSEA). These indices recognized that the following needed to hold true in order to support model fit: The observed values for χ^2/df should be less than 2, the values for CFI should be higher than 0.9, and the RMSEA values should be lower than 0.08 (Marcoulides & Schumacker, 1996). Additionally, the factor parameter estimates for the model with acceptable fit were examined to help interpret the model.

Results

For the analysis of the data we reduced the number of raw scores by conducting exploratory factor analysis (the factors extracted were treated as entering variables in the confirmatory factor analysis). This was done to increase the reliability of the measures fed into the analysis and hence to facilitate the identification of latent variables (Bentler, 1995).

In order to refute the assumption that students' geometrical-figures performance is a unitary construct, a first-order model was examined within the structural equation modeling framework. This model involved only one first-order factor, which associated all of the items involved and could be taken to stand for students' general ability to work with geometry tasks involving different geometrical figures. As reflected by the iterative summary [$\chi^2/df=22.46$; CFI=0.530; RMSEA= .147], this model did not have a good fit to the data and therefore, could not be considered appropriate for explaining students' aforementioned ability.

At this point, we tested a model consisting of six first-order factors, representing six processes involved in manipulating tasks with different geometrical figures: representations of 3D geometrical figures (F1), analysis of 3D geometrical figures (F2), measuring and recognition abilities in 2D geometrical figures (F3), problem solving

involving 2D geometrical figures (F4), manipulation of tasks involving net-representations of cube (F5) and manipulation of tasks involving net-representations of geometrical solids other than the cube (F6). The six factors F1-F6, appearing on the left hand side of Figure 1, are described below.

F1: Representations of 3D geometrical figures. Four variables (V1-V4) construct F1. V1 refers to different representations of a cube, V2 refers representations of pyramids, V3 refers to representations of other geometrical solids and V4 refers to the ability to identify non-representations of 3D figures. Therefore, F1 is called “representations of 3D geometrical figures”.

F2: Analysis of 3D figures. F2 consists of three variables, which refer to students’ ability to analyze 3D figures. V5 refers to the shape of the faces, while V6 refers to the number of the faces of a geometrical solid. V6 refers to analyzing a 3D figure to smaller parts which have been used for its construction.

F3: Measuring and recognition abilities in 2D geometrical figures. Three variables (V8-V10) construct F3. V8 refers to area calculation of simple 2D geometrical figures. V9 refers to the ability to recognize simple 2D geometrical figures, while V10 refers to recognizing simple 2D geometrical figures in complex diagrams.

F4: Problem solving involving 2D geometrical figures. F4 consists of three variables (V11-V13), which refer to students’ abilities to solve geometrical problems involving 2D geometrical figures. V11 refers to area calculation of complex 2D geometrical figures, while V12 and V13 refer to students’ ability to solve problems presenting 2D geometrical figures using geometrical reasoning strategies.

F5: Manipulation of tasks involving net-representations of cube. This factor consists of three variables (V14-V16), which refer to students’ ability to work with different tasks involving net-representations of cube: recognizing different nets of cube (V14), corresponding the drawing with the net of specific cube (V15) and, constructing the net of a cube (V16).

F6: Manipulation of tasks involving net-representations of geometrical solids other than the cube. Three variables (V17-V19) construct F6. V17 refers to the ability to identify net-representations of geometrical solids excluding the non-representations. V18 refers to recognizing simple net-representations (in which the faces of the solid are arranged around the base), while V19 refers to recognizing complex net-representations.

The six first-order factors model did not have a good fit to the data [$\chi^2/df=6.18$; CFI=0.906; RMSEA= .069], so we decided to test a higher order factor model. The proposed framework consisted of the six first-order factors described above, three second-order factors, and one third-order factor. The six first-order factors [recognizing representations of 3D geometrical figures (F1), analysis of 3D geometrical figures (F2), measuring and recognition abilities in 2D geometrical figures (F3), problem solving involving 2D geometrical figures (F4), manipulation of tasks involving net-representations of cube (F5) and manipulation of tasks involving net-representations of geometrical solids other than the cube (F6)] were hypothesized to construct three

second-order factors: ability to work with tasks involving 2D geometrical figures (F7), ability to work with tasks involving 3D geometrical figures (F8), ability to work with net-representations of geometrical solids (F9). These second-order factors are postulated to account for any correlation or covariance between the first-order factors. Finally, the three second-order factors (F7, F8 and F9) were hypothesized to construct a third-order factor “geometrical performance in tasks involving different geometrical figures” (F10) that was assumed to account for any correlation or covariance between the second-order factors.

Figure 1 outlines the structural equation model with the latent factors (F1 – F10) and their indicators. The fit of the model was very good and the descriptive-fit measures indicated support for the hypothesized first, second and third-order latent factors [$\chi^2/df=1.66$, CFI=0.958; RMSEA = .045 (.040, .051)].

This finding indicated that recognizing different representations of 3D geometrical figures, analyzing 3D geometrical figures, measuring and recognizing 2D geometrical figures, solving problems which involve 2D geometrical figures, manipulation of tasks involving net-representations of cube and, manipulation of tasks involving net-representations of geometrical solids other than the cube can represent six distinct functions of students' performance in geometry tasks involving different geometrical figures. Furthermore, it is obvious that ‘recognizing different representations of 3D geometrical figures’ (F1) and ‘analyzing 3D geometrical figures’ (F2) share some common characteristics which can be captured by the second-order factor called “students' ability to work with tasks involving 3D geometrical figures (F7). In the same way, the results indicate that ‘measuring and recognizing 2D geometrical figures’ (F3) and ‘solving problems which involve 2D geometrical figures’ (F4) can be captured by the second-order factor called “students' ability to work with tasks involving 2D geometrical figures (F8), while the second-order factor called “students' ability to work with net-representations of geometrical solids” (F9) is analyzed into two distinct (but with common characteristics) sets of abilities referring to the ability to work with net-representations of cube (F5) and the ability to work with net-representations of other geometrical solids (F6). The presence of a third-order factor in the validated model indicates that, although “students' ability to work with tasks involving 2D geometrical figures”, “students' ability to work with tasks involving 3D geometrical figures” and, “students' ability to work with net-representations of geometrical solids” are To test for possible differences between the three age groups in the structure described above, multiple-group analysis was applied where the third order model was fitted separately on each age group. The model was first tested under the assumption that the structure of students' performance in tasks involving different geometrical figures is the same across the three age groups. The fit of this model was good [$\chi^2/df=1.86$, CFI=0.905; RMSEA = .040 (.039, .042)].

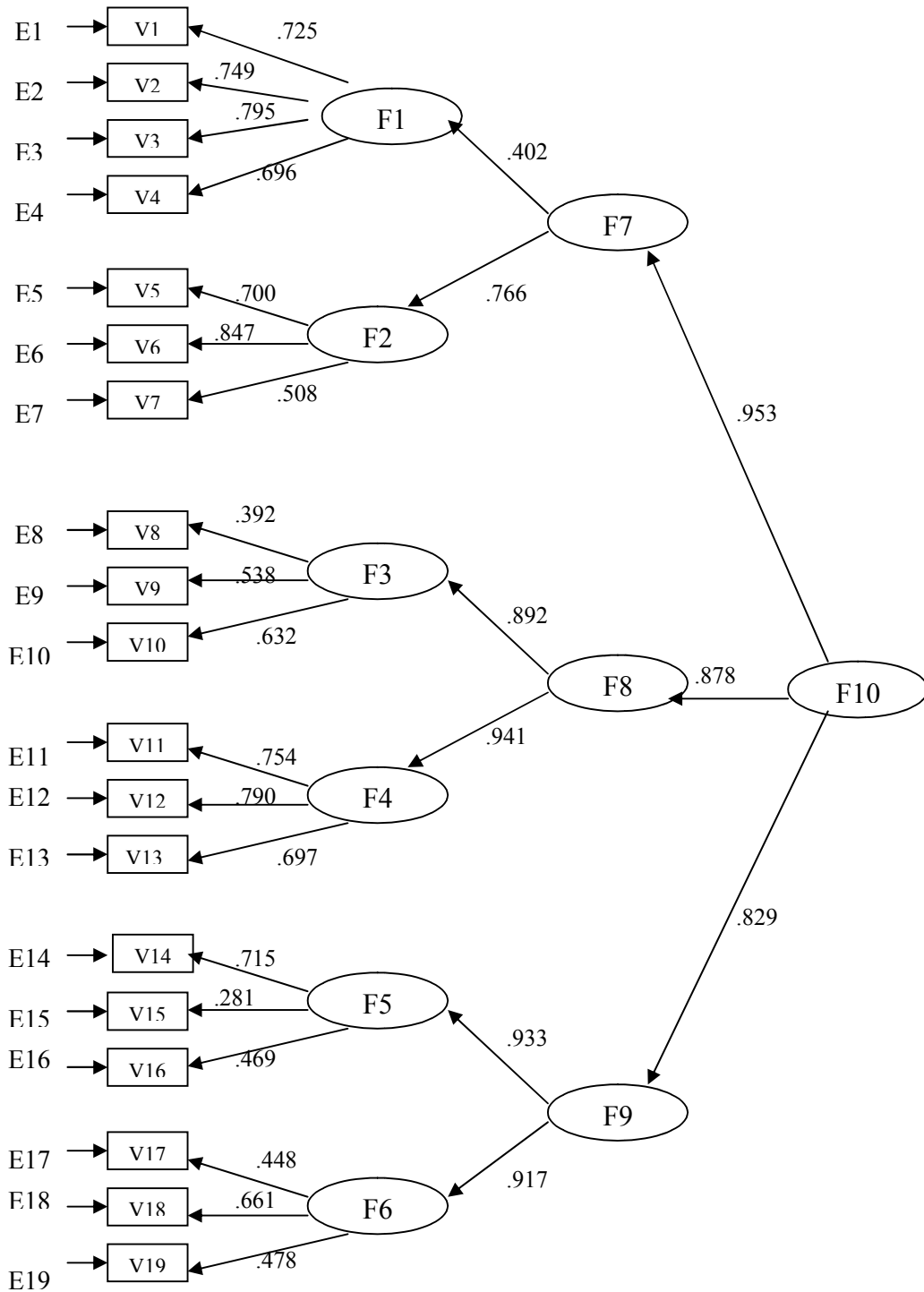

Figure 1: A hierarchical model of students' abilities in tasks involving geometrical figures *

*V1-V19 refer to the factors extracted from exploratory factor analysis conducted using the study's raw data, F1= Representations of 3D geometrical figures, F2= Analysis of 3D figures, F3= Measuring and

recognition abilities in 2D geometrical figures, F4= Problem solving involving 2D geometrical figures, F5= Manipulation of tasks involving net-representations of cube, F6= Manipulation of tasks involving net-representations of geometrical solids other than the cube, F7=ability to work with tasks involving 2D geometrical figures, F8=ability to work with tasks involving 3D geometrical figures, F9=ability to work with net-representations of geometrical solids, F10=geometrical performance in tasks involving different geometrical figures

Subsequent model tests referred to equality constraints on the factor parameter estimates. A model tested under the assumption that all the relations of the variables to the six first-order factors, the first-order factors to the three second-order factors and the second-order factors to the third order factor would be equal across the three age groups was rejected, since the fitting of this model to the data was poor. This finding indicated that some of the equality constraints were not to hold. Holding the equality constraints for the three age groups in the case of the second-order factor “students’ ability to work with tasks involving 3D geometrical figures” (F7) and its subcomponents F1 and F2 and, releasing the constraints for the other factors, the iterative summary reflected that such a model had a good fit to the data [$\chi^2/df=1.87$, CFI=0.905; RMSEA = .041 (.039, .042)].

Obviously, the three fit indices we used to evaluate model fit were very much alike in the case (a) of a model assuming that the structure of students’ performance in tasks involving different geometrical figures is the same across the three age groups and (b) of a model assuming that the structure is the same and additionally the parameters of the factor describing students’ ability to work with 3D geometrical figures are equal. Calculating the difference of chi-square we found that the addition of the equality constraints, which essentially leads us to a simpler model, resulted to statistically significant improvement of the model fit [$\Delta \chi^2(10)=20.922$, $p<0.001$]. Concluding, the second model, which assumes that the structure of students’ performance in tasks involving different geometrical figures is the same across the three age groups and additionally holds for equal parameters of the factor describing students’ ability to work with 3D geometrical figures, is the best model describing our data.

Discussion

The present study was based on the assumption that students’ geometrical knowledge and abilities related to tasks involving different geometrical figures is a multifaceted construct, with subcomponents which are related to the students learning experiences in geometry lessons throughout their schooling years. Although considerable research has been devoted to localized studies on geometrical reasoning or performance, less attention has been paid to the wider picture. The importance of this study lies in the fact that it purported to capture a more holistic view of students’ geometrical performance.

The study aimed to empirically test a model formulated to identify and classify the subcomponents of students’ geometrical performance related to the manipulation of different geometrical figures. The proposed model was validated through data obtained from 4th, 6th and 8th grade students in Cyprus. Confirmatory factor analysis affirmed the existence of six first-order factors (recognizing representations of 3D geometrical figures, analysis of 3D geometrical figures, measuring and recognition abilities in 2D

geometrical figures, problem solving involving 2D geometrical figures, manipulation of tasks involving net-representations of cube and, manipulation of tasks involving net-representations of geometrical solids other than the cube), three second-order factors indicating students' abilities to work with 2D geometrical figures, 3D geometrical figures and, net-representations of geometrical solids respectively and one third-order factor representing the general ability to solve tasks involving different geometrical figures. This framework indicates that students' system of geometrical abilities referring to manipulation of tasks involving different geometrical figures is harmonized with students' learning experiences in such a way that experiences related to a specific domain are embedded into common structures. In other words, this system is constructed so that it processes in different structures the information related to different geometrical figures. The findings of the present study are in line with the results of previous research work which have empirically shown that experiences related to a specific domain are embedded into common structures (Demetriou, 1998; Demetriou 2004; Demetriou & Panaoura, 2006).

Multiple group analysis results provided support for the invariance of the structure described above across the three age groups of students who participated in the study, as well as equality constraints related to the factor describing students' ability to work with 3D geometrical figures. These results indicate that the basic structure of students' abilities to manipulate different geometrical figures begins to be built from the upper classes of elementary school and remains the same until the end of the second year of secondary school. Additionally, the result indicating lack of differences across the three age groups of students on the factor describing their performance in tasks involving 3D geometrical figures means that students' learning experiences in geometry lessons do not result in obvious differentiation of their corresponding abilities. The specific finding is in line with the results of a long-term research started by Hejný and Jirotková showing that the structure related to solids is built in students' minds mainly through visual and tactile perception and depends mostly on their life experience rather than the school mathematics curriculum and geometry classroom teaching (Jirotková & Littler, 2005).

The present study has extended research literature on students' geometrical performance providing, through the proposed model, a framework of students' performance in tasks involving different geometrical figures. This framework provides a theoretical foundation for curriculum designers and for assessment programs in geometry education. It also provides teachers with useful background on students' geometrical reasoning. Accordingly, further research is needed to evaluate the viability of using the proposed framework for informing geometrical instruction in regular classroom situations.

A concluding remark. In classrooms students have the opportunity to learn. But 'the opportunity to learn' may be conceived of as having two major dimensions: (a) the amount of exposure, which includes enrolment, rate, and length, and (b) the quality of exposure, which includes intensity and accessibility (Kilgore & Pendleton, 1993). It is obvious that teachers and students make decisions about these two dimensions. Further

research is needed to investigate how these dimensions affect students' geometrical performance and abilities.

References

- Battista, M. T. (1999). The importance of spatial structuring in geometric reasoning. *Teaching Children Mathematics*, 6(3), 170-177.
- Bentler, P.M. (1995). *EQS Structural Equations Program Manual*. Encino, CA: Multivariate Software Inc.
- Demetriou, A. (1998). Cognitive development. In A. Demetriou, W. Doise, & C.F.M. van Lieshout (Eds.), *Life-Span Developmental Psychology* (pp. 179-270). New York: John Wiley & Sons Ltd.
- Demetriou, A. (2004). Mind, intelligence, and development: A general cognitive, differential, and developmental theory of the mind. In A. Demetriou & A. Raftopoulos (Eds.), *Developmental change: Theories, models and measurement* (pp. 21-73). Cambridge: Cambridge University Press.
- Demetriou, A., & Kazi, S. (2001). *Unity and Modularity in the Mind and the Self*. London: Routledge.
- Demetriou, A., & Panaoura, A. (2006). The development of mathematical reasoning: Its interplay with processing efficiency, self-awareness and self-regulation. In L. Verschaffel, F. Dochy, M. Boekaerts & S. Vosniadou (Eds.), *Essays in honor of Erik de Corte – Advances in learning and instruction* (pp. 19-37). EARLI.
- Demetriou, A., Christou, K., Spanoudis, G., & Platsidou, M. (2002). The development of mental processing: efficiency, working memory, and thinking. *Monographs of the Society for Research in Child Development*, 67 (1). Serial No. 268.
- Duval, R. (1998). Geometry from a cognitive point of view. In C. Mammana & V. Villani (Eds.), *Perspectives on the teaching of geometry for the 21st century* (pp.37-52). Dordrecht: Kluwer Academic.
- Fischbein, E. (1993). The theory of figural concepts. *Educational Studies in Mathematics*, 24 (2), 139-162.
- Gray, E.M., & Tall, D.O. (1994). Duality, ambiguity and flexibility: a perceptual view of simple arithmetic. *Journal for Research in Mathematics Education*, 25(2), 115-141.
- Hejný, M. (2002). Creating mathematical structure. In J. Novotná (Ed.), *Proceedings of CERME2* (pp. 14-24). Prague, Pedf UK.
- Hejný, M. (2003). Understanding and structure. In M. Mariotti (Ed.), *Proceedings of CERME3*. Bellaria, Italy. [On line] National Council of Teachers of Mathematics, (2000). *Principles and Standards for School Mathematics*. Reston, VA: NCTM.

- Houdement, C., & Kuzniak, A. (2003). Elementary geometry split into different geometrical paradigms. In M. Mariotti (Ed.), *Proceedings of CERME 3*. Bellaria, Italy.[On line] [http://www.dm.unipi.it/~didattica/CERME3/draft/proceedings draft](http://www.dm.unipi.it/~didattica/CERME3/draft/proceedings_draft)
- Jirotková, D., & Littler, G. (2005). Classification leading to structure. In M. Bosch (Ed.), *European Research in Mathematics Education IV* (pp. 321-331). Saint Felin de Guixols, Spain: ERME.
- Kirgore, S. B., & Pendleton, W. (1993). The organizational context of learning: Framework for understanding the acquisition of knowledge. *Sociology of Education*, 66 (1), 63-87.
- Marcoullides, G. A., & Schumacker, R. E. (1996). *Advanced structural equation modeling: Issues and techniques*. Mahwah, NJ: Lawrence Erlbaum Publishing.
- Meletiου-Mavrotheris, M., & Stylianou, D. (2003). Advancing from elementary to secondary school mathematics in Cyprus: a step or a leap? In L Rogers and J. Novotná (Eds.), *Effective learning and teaching of mathematics form primary to secondary school* (pp.53-81). Bologna, Italy: Pitagora.
- National Council of Teachers of Mathematics (1989). *Curriculum and Evaluation Standards for School Mathematics*. Reston, VA: NCTM.
- National Council of Teachers of Mathematics, (2000). *Principles and Standards for School Mathematics*. Reston, VA: NCTM.
- Rasch, G. (1980). *Probabilistic Models for Some Intelligence and Attainment Tests*. Chicago: University of Chicago Press.
- Sfard, A. (1991). On the dual nature of mathematical conceptions: reflections on processes and objects as different sides of the same coin. *Educational Studies in Mathematics*, 22, 1-36.
- Shierpinska, A. (1994). *Understanding in Mathematics*. London: Palmer Press.
- van Hiele, P. (1986). *Structure and Insight: A Theory of Mathematics Education*. Orlando, FL: Academic Press.

Appendix: Examples of the tasks used in the study

On the figure sketched freehand here (the real lengths are written in cm), are represented a rectangle ABCD and a circle with center A, passing through D. Find the length of segment EB.

Task involving 2D geometrical figures

← Task involving net-representations of geometrical solids

Task involving 3D geometrical figures

Which of the following represent(s) a net of cube?
Circle your answer(s).

How many small cubes  do we need to construct the following solid?

CHAPTER 3:

Proportionality and Pseudo-Proportionality



Proportional reasoning in elementary and secondary education: Moving beyond the percentages

Modestina Modestou & Athanasios Gagatsis

Department of Education, University of Cyprus

Abstract

This study extends our previous study on proportional reasoning and explores students' behavior on the solution of proportional and non-proportional situations that respond to the routine proportionality and meta-analogical awareness aspect of proportional reasoning, respectively. This was impelled with the help of two written tests involving the recognition and handling of proportional and non-proportional situations, that were administered to elementary and secondary school students from Grade 5 to Grade 9. The results indicate a great discrepancy in students' achievement scores at the two aspects of proportional reasoning, indicating their different nature. A more thorough analysis of students' responses at the items of the two aspects revealed that, irrespectively of their age group, students handled certain tasks similarly but due to the application of different solution strategies.

Introduction

From very early, proportionality has been proved to be a universal mathematical tool of explaining and mastering phenomena in different fields of human activity (Freudenthal, 1973). Proportionality's fundamental importance for everyday life resulted in early systematic attempts towards the definition of the concept. Today however, gaps appear in defining those elements that are directly connected with the ability to use proportions and therefore apply proportional reasoning (Lamon, 1999).

Proportional reasoning is much more complex than often thought (Tourniare & Pulos, 1985), something that makes even more difficult the adequate elaboration of the term “proportional reasoning”. In most of the cases, the way that the concept of proportional reasoning is being perceived is indirectly implied through the tasks that are included in relevant researches (Misailidou & Williams, 2003), as well as in mathematical textbooks. We can assume that the majority of textbook examples and tasks used by researchers constitute the image of the concept of proportionality which is not formally defined but learned to be recognized through experience and usage in relevant contexts (Tall & Vinn, 1981). In particular, proportional reasoning has been traditionally considered synonymous with the ability to solve proportional missing-value problems (Cramer, Post, & Currier, 1993). Therefore, missing-value problems have been naively assumed to provide a valid measure of proportional reasoning.

However, recent research on the illusion of linearity (De Bock, Verschaffel, & Janssens, 1998; Modestou & Gagatsis, 2007; Van Dooren, De Bock, De Bolle, Janssens, & Verschaffel, 2003) suggests that this typical approach of proportional reasoning is not accompanied with understanding of the concept of proportion itself. Pupils, irrespective of age, even though succeeding in solving typical proportional problems, fail to distinguish between proportional and non-proportional situations (De Bock et al, 1998; Modestou & Gagatsis, 2007). Consequently, an illusion of the existence of linearity is created in pupils, resulting in the erroneous use of proportional strategies for the solution of non-proportional situations.

Therefore, a proportional thinker cannot be identified as someone who can mechanically solve a proportion (Cramer et al., 1993). In fact the wide use of rote algorithms, such as the cross multiplication, or even primal additive solution methods, indicates that not all persons who solve correctly a problem involving proportions necessarily use proportional reasoning (Lesh, Post & Behr, 1988; Lamon, 1999). On the contrary, it is the ability to decide whether a problem is being solved by applying direct proportion, inverse proportion, additive reasoning or any other numerical relationship that is essential for proportional reasoning (Karplus, Pulos & Stage, 1983).

Consequently, the implicit model that considers proportional reasoning as identical with the ability to solve routine proportional problems does not prove to be adequate. In fact new research on proportional reasoning (Modestou & Gagatsis, in press) has shown that proportional reasoning is not a one component process but encompasses wider and more complex spectra of cognitive abilities and it can be described better by a three-aspect model. In this model, the aspect of routine proportionality, representing the ability for solving routine proportional tasks has still an indispensable part, but the model is completed with the inclusion of two other aspects. These aspects refer to the handling of verbal and numerical analogies of the form $a:b::c:d$ (analogical reasoning), as well as to the awareness of discerning non-proportional situations (meta-analogical awareness).

The present study expands on the data of the research of Modestou and Gagatsis (in press) by focusing on the way primary and secondary school students handle the proportional and the non-proportional tasks that were used to measure the different aspects of the presented model of proportional reasoning. In particular, the main aim of this study is to explore students' behavior while handling proportional reasoning tasks, by means of finding similarities or disparities between different ages and between tasks themselves. This exploration does not take into account only students' achievement scores in the different tasks but also the strategies applied for the solution of each task.

Theoretical framework

Throughout the literature the ability to construct and algebraically solve proportions is implicitly considered as a fundamental component of proportional reasoning (Lamon, 1999). This aspect of proportional reasoning includes second-ordered relations that involve an equivalent relationship between two ratios (Demetriou, Platsidou, Efklides, Metallidou, & Shayer, 1991). The existence of a relation between two relations and the

recognition of this structural similarity is according to Piaget (Piaget & Inhelder, 1958) the essential characteristic of proportionality. Every proportional relation involves the same pattern of relations or operations and the components are multiplicatively related (Lesh et al., 1998). It can be represented graphically by a straight line passing through the origin and therefore, at the same time refers to the linear function of the form $f(x) = ax$ (with $a \neq 0$) (Van Dooren et al., 2003).

Vergnaud (1983) suggests that there is essentially one situation model involved in the understanding of simple proportional relationships: the isomorphism of measures model. In this model, parallel transformations can be carried out within or between the variables-measures maintaining their values proportional. These transformations reflect the different methods-strategies that can be used to solve the problems and indicate the type of comparison preferred by the pupils (Karplus et al., 1983). For example, consider the following problem: “If 5 pencils cost 40 cents, how much do 15 pencils cost?”. There are two measure spaces in this problem: The first one contains the set of the cardinalities of the two sets of pencils and the other contains the cardinalities of the two sets of cents. The within measures strategy compares the number of pencils to the number of pencils and the amount of money to the amount of money. These two relations form the ratios $5/15$ and $40/x$. The between measures strategy compares the number of pencils to the corresponding amount of money and form the ratios $5/40$ and $15/x$.

Proportional tasks can also be assigned to different categories according to their linguistic structure. The basic linguistic structure for problems involving proportionality is that of missing-value, like the one given above, which is presented with three numbers a , b , and c and the task is to find the unknown x such as $a/b=c/x$ (Tourniare & Pulos, 1985). However, this format is not always accompanied with multiplicative solution methods, as numerous pupils are inclined towards using primitive additive strategies. In addition, the missing-value format has been linked with pupils’ tendency to use the mnemonic “cross-multiply” rule, which in most cases precludes the use of proportional reasoning (Lest et al., 1988; Lamon, 1999). This rule is especially popular in Cyprus, as it is formally presented through 6th and 8th Grade mathematic textbooks. In addition to the cross multiplication strategy, Cypriot students use also “the rule of three”, according to which, in order to solve a missing-value proportional problem one just had to multiply the second quantity presented in the problem with the third one and divide it by the first. Therefore, the connection between the missing-value format and mechanical methods for solving proportional tasks is something well cultivated in Cyprus.

The comparison tasks, a different kind of tasks for studying pupils’ proportional reasoning, are not accompanied with the “problem” of the application of a rote rule, but are more rarely used. These tasks are presented with four numbers a , b , c , and d and pupils are asked to determine whether they form a proportion. For example, a reformulation of the previous missing-value task into a comparison task would be: “A set of 5 pencils cost 40 cents. A set of 15 pencils cost €1.10. In which set the pencils are cheaper?”.

The missing-value format is not only associated with the application of superficial rote rules in proportional tasks. Greer (1997) points out that multiplicative missing-value structure is also connected with the inappropriate invocation of proportionality, as a result of an unconscious reaction to linguistic form. In fact recent research on the phenomenon of the illusion of linearity has shown that students, irrespective of age, fail to distinguish between proportional and non-proportional situations with similar linguistic characteristics. Thereafter they handle the non-proportional situations as proportional, by applying the same strategies.

We can claim that this behavior indicates students' lack of a fundamental aspect of proportional reasoning that lies in the success of analyzing the quantities in a given situation in order to establish whether or not a proportional relation exists (Karplus et al., 1983; Lamon, 1999). This aspect defined as meta-analogical awareness (Modestou & Gagatsis, in press) is closely related with the illusion of linearity as it refers to the awareness of situations which appear proportional but are not. For example, students' response that a five year old boy of 83cm of height will be 1.66m when he gets to the age of ten is characteristic of this lack of meta-analogical awareness and consequently of the illusion of linearity. Students fail to determine the non-proportional nature of the task and therefore apply proportional strategies for its solution, without taking into consideration its realistic constraints.

Another well known example, indicating students' limited meta-analogical awareness appears in the field of geometry and it concerns relations between the side's length and the reduced or enlarged figure's area or volume. Different studies (De Bock et al., 1998; Modestou & Gagatsis, 2007; Van Dooren et al., 2003) have revealed that the majority of students (even 16 year old) fail in handling non-proportional problems in this field because of the created "illusion" that the area and volume of a geometrical figure is enlarged x times when the dimensions are enlarged x times. These tasks are included in the study of the meta-analogical awareness aspect of proportional reasoning.

Method

Participants

The sample of the study consisted of 982 students of Grades 5- 9 (10-14 year olds) of different elementary and secondary schools covering all provinces of Cyprus. In particular, 184 students attended the 5th Grade, 199 the 6th Grade, 221 students the 7th Grade, 186 the 8th Grade and the remaining 155 students attended the 9th Grade. These grades were chosen as suitable for the study as they enable the study of students' transition from elementary to secondary education and at the same time mark the end of the mandatory education in Cyprus. Therefore, it was intended to explore the way students' proportional reasoning is reflected between ages that students are obliged to change scenery in education.

Test Batteries

The items used in this study addressed the routine proportionality and meta-analogical awareness aspects of proportional reasoning. These items were organized

into two tests that included tasks addressing both aspects, in order to avoid any possible influence of the task category on the participants. It must be noted here that one could claim that even though a pupil proves able to discern proportional from non-proportional items will not necessarily discern them in all cases. Although this is possible, the whole design of this study is based on the fact that the items used in tests provide clear indications for students' abilities in the two different aspects of proportional reasoning.

Table 1: Example of the Items Included in Test I –Direct Measures

Part A	<p>“If a 9 year-old boy is 1.23m tall then at his 18th birthday will be 2.46m” The statement is correct/incorrect, because.....</p> <p><u>Cod.</u> <i>Complete only if the statement is incorrect</i> <u>st1-st6</u></p> <p>Can the statement be corrected by changing only one number? If yes, in what way? If no, explain why.....</p> <p style="text-align: right;">(Lamon, 1999)</p>
Part B	<p>Recipe for chocolate cake for three 120g chocolate 9 spoons of cream 3 eggs 4 spoons of coffee liqueur 4 spoons of sugar</p> <p><u>Cod.</u> <u>pmv1-</u> <u>pmv3</u></p> <p>“Mother wants to bake the cake for four persons instead of three. How much sugar will she need?”</p> <p style="text-align: right;">(Misailidou & Williams, 1998)</p>
Part C	<p>“John makes concentrate by using 6 spoonfuls of sugar and 12 cups of lemon juice. Mary makes concentrate by 4 using spoonfuls of sugar and 7 cups of lemon juice.</p> <p><u>Cod.</u> <u>pc1-pc3</u></p> <p>John/ Mary has the sweeter lemonade because..... In order both children have the same lemonade.....</p> <p style="text-align: right;">(Karplus et al., 1983)</p>

The first test (Test I) consisted of three parts that required students to:

(a) Recognise if a statement is correct or not and to change it, if possible, in order to become mathematically acceptable. Six statements were included in this section, each of which included four quantities. The relation between these quantities was proportional (proportional statements) or constant, additive or unknown (non-proportional statements). The four non-proportional statements were formulated in such a way that they could easily mislead pupils to treat them as proportional and therefore state that they are correct (see for example Table 1, part A). Therefore, in order to handle these

tasks pupils should have been able first to discriminate the proportional from the non-proportional statements and then correct them if possible.

(b) Solve proportional missing-value tasks which were given in the context of a cake recipe that needs to change in order to be suitable for more persons (see Table 1, part B) and

(c) Solve proportional comparison tasks that concerned the sweetness of two lemonades (see Table 1, part C). In sections (b) and (c), the proportional missing-value and comparison tasks were direct, in the sense that the relation between the two quantities in each task was directly proportional (Van Dooren et al., 2003).

The second test (Test II) comprised four proportional and four non-proportional tasks that were also presented in a missing-value and comparison format (see Table 2). These tasks were geometrical. That is, the proportional tasks referred to the linear enlargement of the perimeter of rectangular and circular figures and the non-proportional tasks referred to the square enlargement of the area of respective figures. All the tasks involved indirect measures for indicating the perimeter and the area of the figure (Van Dooren et al., 2003). For instance the ribbon that was going to be sewed around a tablecloth was used as an indirect measure of perimeter, while the paint for covering the interior of a picture was used as an indirect measure for area.

Table 2: Example of the Items Included in Test II –Indirect Measures

Missing- value format Non-proportional Area <u>Cod. npmv1, npmv2</u>	If 8ml of paint are needed in order to fill the inside of a square picture with 4cm of length, how much paint is needed for an enlargement of the same picture with 12cm of length?
Comparison format Proportional Perimeter <u>Cod. ppc3, ppc4</u>	Ann needs 5 minutes in order to sew a ribbon around a square towel of 30cm length. She calculated that it will take her 30 minutes to sew the same ribbon around a square tablecloth of 180cm of length. Are Ann's calculations correct? If not, how much time will she need for the tablecloth?

Methods of data analysis

Students' answers to the tasks of the tests were not simply codified as correct or wrong. On the contrary, depending on the degree and the way each student handle each task, a different mark could be assigned ranging from 0 (wrong answer) to 1 (completely correct answer). The in-between marks were 0.25 (presenting a number with no justification), 0.5 (conducting one from two steps) and 0.75 (indicating correct reasoning but with errors in the application of the procedure). It must be noted that the explanations given in brackets are indicative and were adjusted depending on the task itself.

For the analysis of the collected data two different analyses were conducted: An Implicative Statistical Analysis, with the use of the computer software CHIC (Bodin, Coutourier, & Gras, 2000) and a Multivariate Analysis of Variance (MANOVA). The multivariate analysis of variance (MANOVA) was performed to specify the possible influence of students' age on their performance on tasks representing different aspects of proportional reasoning.

The implicative statistical analysis enables the distribution and classification of variables, as well as the implicative identification among the variables or variable categories (Modestou & Gagatsis, 2007). It generated two similarity diagrams of students' responses at the tasks of both tests, referring to the two different aspects of proportional reasoning, examined here. The similarity diagram, which is analogous to the results of the more common method of cluster analysis, allows the arrangement of the tasks into groups according to the homogeneity by which they were handled by students.

Results

The results of this study are organised into two parts based on the method of analysis they derived from. The first part focuses on an exploration of students' achievement scores at the tasks included in the two aspects of proportional reasoning described in previous sections, in relation to grade. The second part deals with possible similarities in the way students handled the different tasks, similarities that cannot be derived only through the study of students' success percentages at the different tasks.

Exploration of the routine proportionality and meta-analogical awareness aspect of proportional reasoning in relation to grade

Routine proportionality aspect. Pupils' mean achievement scores in the four categories of proportional tasks did not differentiate in the same way in relation to pupils' age (see Figure1). A multivariate analysis of variance was used with dependent variables pupils' mean achievement scores at the categories of the missing-value proportional tasks with direct measures, comparison proportional tasks with direct measures, missing-value proportional tasks with indirect measures and comparison proportional tasks with indirect measures. This analysis was applied in order to examine whether the observed differences between the five age groups were statistically significant. Pupils' grade was used as an independent variable. The results of the analysis showed that statistically significant differences exist (Pillai's $F_{(4,937)} = 11.52$, $p < .001$) between the five age groups for the different categories of proportional tasks.

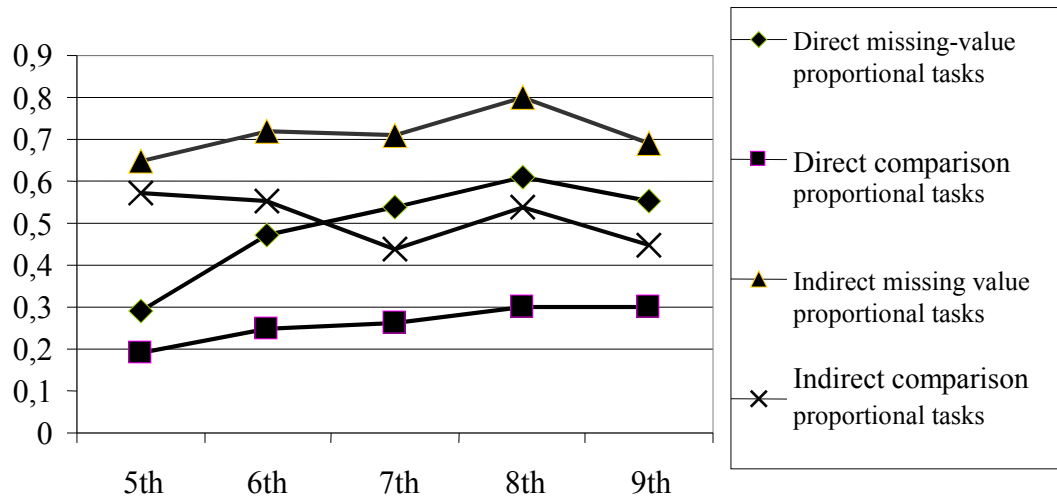

Figure 1. Students' mean achievements scores at the proportional tasks (routine proportionality aspect)

The polynomial contrast post hoc analysis revealed the grades amongst which statistically significant differences exist for the categories of the proportional tasks with direct and indirect measures. Pupils presented statistically significant improvement on all proportional tasks presented with direct measures when passing from Grade 5 to Grade 6 ($t_{mv}=5.25$, $p<.001$; $t_c=4.08$, $p<.001$), as well as when passing from Grade 7 to Grade 8 ($t_{mv}= 2.43$, $p<.05$; $t_c=2.39$, $p<.05$). Similar results were observed and in the case of the proportional tasks with indirect measures. In particular, students' mean achievement scores in the missing value tasks were improved when passing from Grade 5 to Grade 6 ($t_{mv}=2.00$, $p<.05$), as well as when passing from Grade 7 to Grade 8 ($t_{mv}= 2.71$, $p<.01$). However, in the case of the comparison tasks with indirect measures statistically significant improvement was observed only among Grade 7 and Grade 8 ($t_c=2.39$, $p<.05$).

These results provide strong indications of the fact that students' ability to solve routine proportionality tasks is affected by teaching. In fact all the statistically significant improvements of students' mean achievement scores can be explained if we considered the fact that 6th and 8th graders receive systematic teaching in proportional relations through mathematics' textbooks. This teaching is in its majority based on solving similar proportional tasks with the use of mechanical strategies, something that can justify 6th and 8th graders better performance compared to 7th and 9th graders, respectively.

Meta-analogical awareness aspect. The majority of the non-proportional tasks referring to the aspect of meta-analogical awareness created substantial difficulties to all pupils, irrespectively of their grade, compared to the proportional tasks of the routine proportionality aspect (see Figure 2). Within this aspect of meta-analogical awareness pupils' achievement scores in the categories of the non-proportional items with indirect

measures and of the non-proportional statements appeared to be static in all grades of the elementary school (Grade 5 and 6) as well as the first two grades of the secondary education (Grade 7 and 8). An improvement was only observed in the achievement scores of the 9th Grade. The results of the multivariate analysis of variance showed the age groups for which statistically significant differences exist (Pillai's $F(4,937) = 13.72$, $p < .001$) for the tasks belonging to the aspect of meta-analogical awareness.

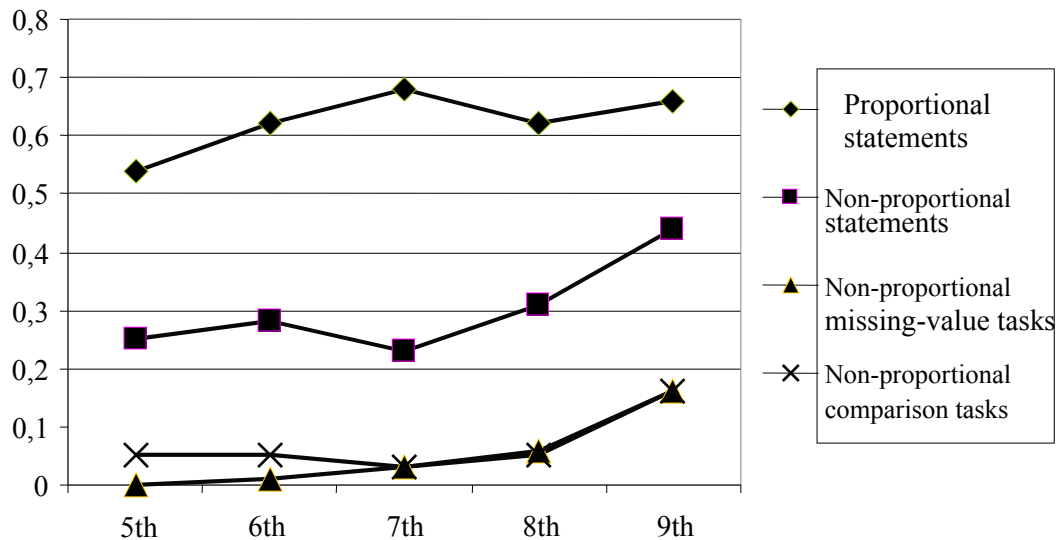

Figure 2. Students' mean achievements scores at the non-proportional tasks (meta-analogical awareness aspect)

The polynomial contrast post hoc analysis showed that in the case of the proportional statements statistically significant differences exist only at students' transition from 5th to 6th Grade ($t_p=2.72$, $p<.01$). On the contrary, in the case of the non-proportional tasks statistically significant differences were mostly observed amongst the 8th and 9th Grade for both tasks that involve the recognition of the non-proportional statements ($t_{npst}=4.92$, $p<.001$), as well as the solution of the non-proportional situations presented either in a missing value ($t_{nmpv}=3.97$, $p<.001$) or a comparison format ($t_{npc}=6.10$, $p<.001$). These patterns may suggest that the meta-analogical awareness aspect of proportional reasoning begins to develop only by the end of the compulsory secondary education.

Exploration of the relations among the tasks of the different aspects of proportional reasoning revealed by the implicative statistical analysis

A different analysis by means of the computer software CHIC (Bodin, et al., 2000) was conducted in order to provide insights regarding the relations between the tasks themselves. These relations are revealed by the formulation of different groups of tasks, in respect to students' way of handling these tasks. Figure 3, illustrates the similarity

diagram of all proportional and non-proportional tasks included in Tests I and II, for Grades 5 and 6 (elementary education). Students' responses at each task form the different variables. All the statistically significant relations are indicated with a thick red line.

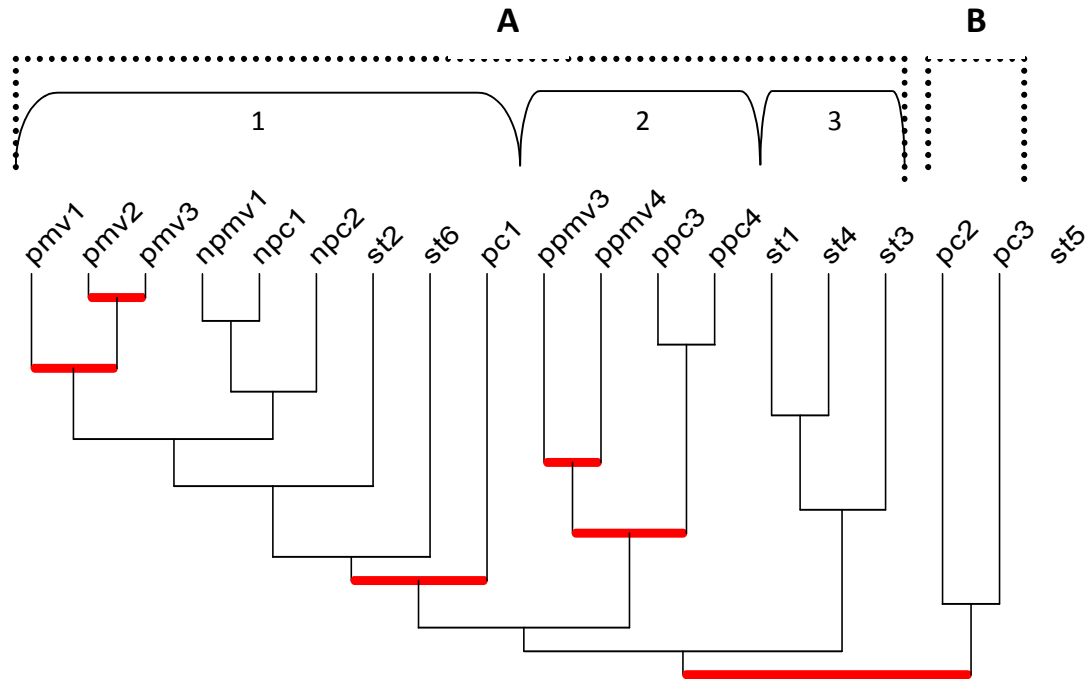

Figure 3. Similarity diagram amongst the routine proportionality and meta-analogical awareness tasks, handled by 5th and 6th graders of the elementary education.

Students' responses to the tasks form two clusters (i.e., groups of variables) of similarity, where the smaller one (B) consists only of the two proportional comparison tasks of Test I that refer to the sweetness of lemonade (pc2, pc3). The third comparison task of the same category (pc1) is part of the first and larger sub-cluster of similarity (A1). This sub-cluster consists of elementary school students' responses at the proportional missing-value tasks (pmv1, pmv2, pmv3) of Test I, at the non-proportional tasks (npc1, npc2, npmv1) of Test II and finally at the proportional statements of Test I (st2, st6). In this sub-cluster of similarity the stronger relations lie among tasks pmv1, pmv2 and pmv3, where the statistically significant similarity index of 1 indicates that elementary school students handled these tasks as identical, irrespectively of the existence of an integer or a non-integer ratio among the quantities.

In particular, the majority of the 5th and 6th graders that successfully solved the specific tasks applied the unit-rate strategy. This strategy constitutes the factor contributing the most at the formation of the specific sub-cluster. This is something very much expected if we consider the fact that this is the strategy emphasized the most in elementary school teaching, and in the respective mathematical textbooks. According to this strategy, in order to determine the total unknown quantity you divide the total given

quantity by the quantity per unit to obtain the number of units and then multiply the number of units by the corresponding quantity per unit (Christou & Pilippou, 2002).

Very strong similarly relations are also observed in the second sub-cluster of similarity (A2) which is formed by students' solutions at the indirect proportional tasks of Test II (ppmv3, ppmv4, ppc3, ppc4). The statistically significant relations indicate that students' solutions were not affected by the linguistic formulation of the tasks (missing-value and comparison) and handled the tasks similarly. In fact for the solution of these tasks the majority of students preferred the application of a within measures strategy. This strategy is based on finding the ratio between the quantities of one measure and then applying it to the other measure in order to find the unknown quantity.

It must be noted here that the within measures strategy also reflected students handling of the non-proportional items (sub-cluster A1). This provides a clear indication of students' inability to discriminate these non-proportional situations and apply proper strategies for their solution. Elementary school students' responses at the non-proportional statements of Test I (st1, st3, st4) did not participate in the formation of the same similarity cluster as the non-proportional items. These statements constituted a different similarity sub-cluster (A3), something that indicates that elementary school students could not eliminate the specific characteristics that made all the items belonging to the meta-analogical awareness aspect of proportional reasoning, similar.

When applying the same method of analysis to secondary students' responses at the same tasks, similar clusters of similarity arise, but due to the application of different strategies (see Figure 4). One large cluster of similarity is presented which is formulated by five similarity sub-clusters. These sub-clusters include exclusively either proportional (Clusters 1, 3, 4, 5) or non-proportional tasks (Cluster 2), but not a combination of both. In particular, Cluster 2 is formed by all tasks related with the meta-analogical awareness aspect of proportional reasoning. These tasks include the recognition of the non-proportional statements (st1, st3, st4) as well as the solution of non-proportional tasks presented either in a comparison (npc1, npc2), or missing-value format (npmv1, npmv2). The grouping of these tasks indicates that students' handled the non-proportional tasks in a similar manner irrespectively of the context that were presented, recognizing their common non-proportional character. In particular, this similar handling lies in the application of a correct strategy for the solution of the non-proportional situations. According to this strategy, students solved the non-proportional items with indirect reference to the area, by first finding the area of the given shape and then applying direct proportionality in relation the known measure (i.e. side's length).

This however, is not the case with the tasks belonging to the routine proportionality aspect of proportional reasoning. These tasks are grouped into four different similarity clusters based on their linguistic and context formulation. In particular, Cluster 4 is created by students' responses at the two proportional statement items (st2, st6). Cluster 1 is formulated by the direct missing-value proportional tasks of Test I (pmv1, pmv2, pmv3), whereas Cluster 3 is formed by secondary school students' responses to the

respective direct comparison proportional tasks of Test II (pc1, pc2, pc3). In the case of the indirect proportional tasks of Test II (ppmv3, ppmv4, ppc3, ppc4), their linguistic formulation into comparison and missing-value tasks did not affect students' way of handling. Therefore, these tasks are included in the same similarity cluster (Cluster 5) with a very high similarity index (0.9859). Behind the formation of these clusters of similarity with proportional items (Clusters 1, 3 and 5) lies the application of the cross multiplication strategy, a strategy widely used in the secondary education and especially in the 8th Grade.

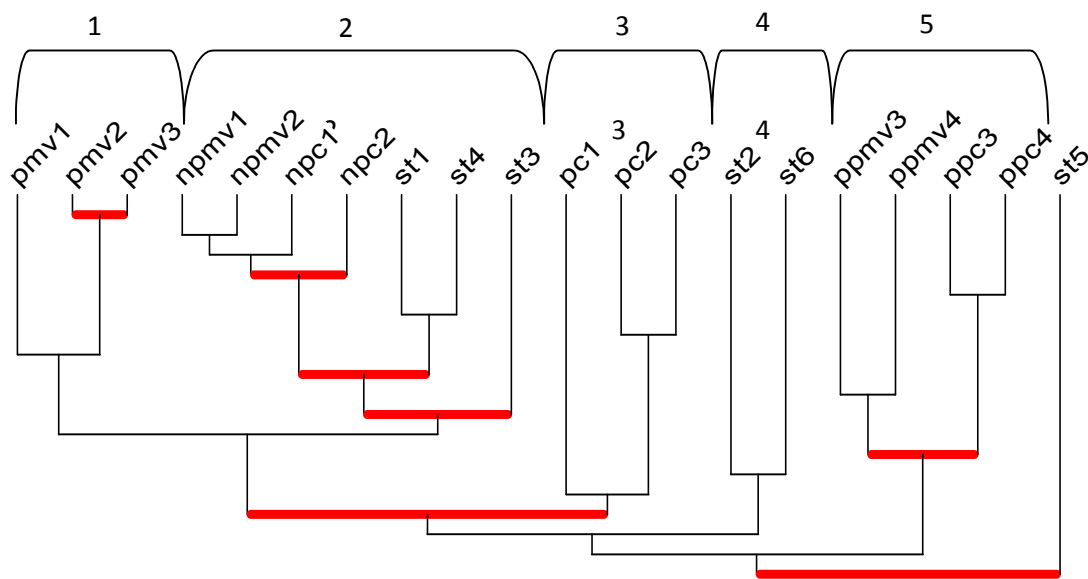

Figure 4. Similarity diagram amongst the routine proportionality and meta-analogical awareness tasks, handled by 7th, 8th and 9th graders of the secondary education.

When we compare the two similarity diagrams (Figures 3 and 4), deriving from the responses of elementary and secondary students respectively, we find a lot of common elements. In fact all the similarity sub-clusters described above can be found both in elementary and secondary education but in different places and with different connections between them. This however does not indicate that elementary and secondary school students handled these tasks in the same way. Behind the same sub-clusters of similarity lie different factors in the elementary and secondary education that affected students in handling certain tasks in the same way. These factors are the different strategies that students applied for solving the items included in both Tests. Therefore, while in the elementary school the factors contributing the most to the formation of the proportional clusters of similarity are the within measures and the unit-rate strategy, in the secondary education students prefer the cross-multiplication strategy. In the case of the similarity clusters with the non-proportional items, significant differences arise as their similar handling by elementary school students is due to the application of an improper proportional strategy due to students' inability to

discriminate them from the proportional ones. On the other hand in secondary education, students, especially in the 9th Grade, begin to recognize the non-proportional situations and therefore apply proper strategies for their solution.

Discussion

The main aim of the present study was to explore students' behavior while handling proportional reasoning tasks referring to two different aspects of proportional reasoning, the routine proportionality and meta-analogical awareness aspects. This was achieved by means of finding similarities or disparities between different ages and between tasks themselves. The results confirmed the great discrepancies in students' achievements scores in tasks belonging to different aspects of proportional reasoning, irrespectively of students' grade (De Bock et al, 1998; Van Dooren et al., 2003). In fact pupils' achievement scores at the non-proportional tasks were extremely low compared to their respective performance at the tasks of the routine proportionality aspect, especially at Grades 5, 6, 7 and 8. The implicative statistical analysis also revealed that especially in the case of the elementary school, students handled the non-proportional items in the same way as proportional by erroneously applying the same proportional strategies.

These results confirm previous arguments (Modestou & Gagatsis, 2007) according to which pupils' ability to handle non-proportional situations, and therefore their meta-analogical awareness, is influenced by the epistemological obstacle of linearity. This obstacle is not a difficulty or a lack of knowledge but it occurs because of the appearance of the concept of linearity. Linearity produces responses which are appropriate within the context of proportional situations but outside this context, in the case of non-proportional situations that are included in the meta-analogical awareness aspect, it generates false responses (Modestou & Gagatsis, 2007). Consequently the aspect of meta-analogical awareness is attained with a more epistemological character and it begins to appear only by the end of the compulsory secondary education.

When dealing with the proportional tasks of the routine proportionality aspect of proportional reasoning, students displayed a rather bazaar behavior. Students' mean achievement scores even though improving significantly from grade to grade, they decreased when passing from Grade 6 to Grade 7 and from Grade 8 and Grade 9. This can be considered as a result of the systematic teaching that 6th and 8th graders receive in proportional relations. In fact students in these grades become expert in solving proportionality problems quickly and accurately with the help of automatized procedures. In Grade 6, students focus on the use of the unit-rate strategy whereas in Grade 8 on the application of the cross multiplication strategy. Therefore, students apply the same exclusive strategy for the solution of all the proportional tasks depending from the grade they study in and the strategies taught in that grade.

However, the exclusive use of one strategy (i.e. unit rate in elementary school and cross multiplication in secondary education) without a meaningful understanding of multiplicative reasoning becomes a procedurally oriented operation that disembodies from students' initial sense making of proportional reasoning. Students' expertise is

proved to be only routine and not adaptive as it was not accompanied with understanding of how and why procedures work and how these procedures can be modified to suit the constraints of a problem (Hatano, 1988). Therefore, the rote use of these automatized procedures appears to be responsible for the occurrence of high achievement scores in these grades that do not represent pupils' real abilities in solving proportional tasks. These results show that the teaching of mathematics is not a simple transfer relation from the teacher to the student. The students in the 7th and 9th Grade disregard in some degree the mechanical strategies being taught in earlier years and use primal additive strategies, being this way more prone to mistakes (Modestou & Gagatsis, in press). Therefore, it is evident that the aspect of routine proportionality is affected by teaching together with age, factors that do not affect in the same way the meta-analogical awareness aspect of proportional reasoning.

References

- Bodin, A., Coutourier, R., & Gras, R. (2000). *CHIC : Classification Hierarchique Implicative et Cohesive-Version sous Windows – CHIC 1.2*. Rennes: Association pour le Recherche en Didactique des Mathematiques.
- Christou, C., & Philippou, G. (2002) Mapping and development of intuitive proportional thinking. *Journal of Mathematical Behavior*, 20, 321-336.
- Cramer, K., Post, T., & Currier, S. (1993). Learning and teaching ratio and proportion: Research implications. In D. T. Owens (Ed.), *Research ideas for the classroom: Middle grades mathematics* (pp. 159-178). New York: Macmillan.
- De Bock, D., Verschaffel, L., & Janssens, D. (1998). The predominance of the linear model in secondary school students' solutions of word problems involving length and area of similar plane figures. *Educational Studies in Mathematics*, 35, 65-85.
- Demetriou, A., Platsidou, M., Efklides A., Metallidou, Y., & Shayer, M. (1991). Structure and sequence of the quantitative-relational abilities and processing potential from childhood and adolescence. *Learning and Instruction*, 1, 19-44.
- Freudenthal, H. (1973). *Mathematics as an educational task*. Dordrecht: Reidel.
- Greer, B. (1997). Modeling reality in mathematics classroom: the case of word problems. *Learning and Instruction*, 7 (4), 293-307.
- Hatano, G. (1988). Social and motivational bases for mathematical understanding. In G. B. Saxe & M. Gearhart (Eds.), *Children's mathematics* (pp. 55–70). San Francisco: Jossey-Bass.
- Inhelder, B., & Piaget, J. (1958). *The growth of logical thinking from childhood to adolescence*. New York: Basic Books.
- Karplus, R., Pulos, S., & Stage, K. E. (1983). Proportional reasoning of early adolescents. In R. Lesh & M. Landau (Eds.), *Acquisition of mathematical concepts and process* (pp. 45-90). New York: Academic Press.

- Lamon, J. S. (1999). *Teaching fractions and ratios for understanding: Essential content knowledge and instructional strategies for teachers*. Mahwah, NJ: Lawrence Erlbaum Associates.
- Lesh, R., Post, T., & Behr, M. (1988). Proportional reasoning. In J. Hiebert & M. Behr (Eds.), *Number concepts and operations in the middle grades* (pp. 93- 118). NCTM: Lawrence Erlbaum Associates.
- Misailidou, C., & Williams, J. (2003). Diagnostic assessment of children's proportional reasoning. *Journal of Mathematical Behaviour*, 22, 335-368.
- Modestou, M., & Gagatsis, A. (in press). Cognitive and metacognitive aspects of proportional reasoning. *Mathematical Teaching and Learning*.
- Modestou, M., & Gagatsis, A. (2007). Students' improper proportional reasoning: A result of the epistemological obstacle of "linearity". *Educational Psychology*, 27 (1), 75-92.
- Tall, D., & Vinn, S. (1981). Concept image and concept definition in Mathematics with particular reference to limits and continuity. *Educational Studies in Mathematics*, 12, 151-169.
- Tourniare, F., & Pulos, S. (1985). Proportional reasoning: A review of the literature. *Educational Studies in Mathematics*, 16, 181-204.
- Van Dooren, W., De Bock, D., De Bolle, E., Janssens, D., & Verschaffel, L. (2003). Secondary school students' improper proportional reasoning: The role of direct versus indirect measures. *Mediterranean Journal for Research in Mathematics Education*, 2, 1-18.
- Vergnaud, G. (1983). Multiplicative structures. In R. Lesh & M. Landau (Eds.), *Acquisition of mathematical concepts and process* (pp.127-174). Academic Press.



Prospective teachers' application of the mathematical concept of proportion in real life situations

Charalambos Lemonidis

University of Western Macedonia, Greece

Abstract

This paper aims to examine if the undergraduate students of the Department of Education, University of Cyprus, are able to transfer their mathematical knowledge and to contextualize it in everyday life. More specifically, their ability to connect the mathematical concepts of direct and inverse proportion with everyday life examples was investigated. Generally speaking, the results show that it is not easy for the students to make connections between mathematical concepts and real life and that knowing the mathematical concept itself is not sufficient to enable connections. It was evident that prospective teachers propose a limited range of everyday examples for proportional situations and they consider many situations that are not proportional as being proportional.

Introduction

A modern tendency in mathematics teaching is the effort to bridge the gap between school mathematics and everyday life mathematics. Therefore, innovative curricula have been applied internationally, for example Standards 2000 in the U.S.A, Numeracy program in England, Realistic Mathematics in Holland, Everyday Mathematics in the University of Chicago (Isaacs, et al., 1998), "Nature and Life Mathematics" in Greece, (Lemonidis, Ch., 2005) etc.

This new perception of Mathematics teaching according to which a greater connection between school Mathematics and everyday life situations, student's experiences and preexisting knowledge should exist, teachers are expected to have certain skills. They should be able to make connections between school mathematics and real life mathematics. In a constructivist and discovery-orientated teaching, where we move from concrete to abstract, what usually happens is the decontextualization of empirical situations and, by means of successive abstractions, a movement towards formal mathematical concepts which are the lesson objectives. A necessary condition to reach these objectives is the teacher's ability to contextualize mathematical concepts that he/she already knows. That is to say he/she is able to find and select the suitable applications to teach the mathematical concepts of a lesson.

There is limited research concerning teachers' or future teachers' abilities to transfer mathematical knowledge in real contexts.

A case concerning the education of future schoolteachers within the frame of "Nature and Life Mathematics" is presented by Lemonidis (Lemonidis Ch., 2005). The conclusions drawn in that paper indicate that the connections between mathematical

concepts and everyday situations are not made automatically by the prospective teachers. A special intervention is essential, so that they become able to use richer and more profound activities from everyday routine when teaching. In this paper I try to examine the ability of prospective teachers to transfer and to connect the mathematical concept of proportional and inversely proportional quantities with applications in everyday life.

Theoretical background

The issue of **transfer of learning**, from a psychological, sociological and educational point of view, has recently been debated in the research community, but important aspects concerning the process of transfer of learning itself in relation to everyday life and realistic situations have not been clarified. Many researches about the importance of transfer of learning in different contexts have been conducted. However, according to the research, the way the transfer process works and the ways it can emerge and be facilitated are not found yet (Royer et al, 2005).

Moreover, there is only limited research that examines the transfer of knowledge in general, and in mathematics in particular, from the school class in everyday life situations or vice versa (Pugh and Bergin, 2005).

This transfer can take the following forms: Use of a school subject (eg. mathematics) in a different context (e.g. physics or economics), application of knowledge from a pedagogical context (e.g. school) in workplace or everyday life, harnessing of out of school activities to facilitate learning in school.

From a cognitive point of view, transfer is defined by Hammer et al. (2005) and other researchers, as the knowledge/capability that an individual acquires in a certain context and the transfer of this knowledge/capability in another context. Evans (2000, p. 5) agrees with this definition and he mentions that the transfer is the use of ideas and knowledge from a context (region or field) in another.

Researchers who are interested in a re-development of the idea of transfer or in the development of different mechanisms in order to explain the obvious continuity of in and out-of school experience, tend to shift the responsibility of the process of transfer from the individual and transmit it to the communities (Boaler, 1993, reference in Lobato and Siebert, 2002).

Placing emphasis in this point, in the effect of the social and cultural environment, it is remarkable that this effect seems to be more intense when it is about the transfer of mathematical knowledge and skills to out-of-school situations, everyday life or vice versa (Stanic and Lester, 1989). Often, in real life situations, the individuals understand mathematical concepts and use mathematical processes in a different way than taught and learned at school (Stanic and Lester, 1989; Masingila et al., 1996).

According to Masingila et al. (1996) there should be a constant interaction between in and out-of school mathematical experience, in order to bridge the gap that keeps apart classroom practices and everyday life. Boaler (1993) as well as Stanic & Lester (1989) agree with Masingila et al. and add that maths should have a special important meaning for children, so as to solve the problem of transfer and to bridge the gap between school

and real life. Schoenfeld (Hung, 2000) claims that the knowledge on how to use maths also includes understanding the meaning of real life situations. Moreover, Lemire (2002), despite his previous opposition, points out that since mathematics are taught at school, it should be taught properly, incorporating mathematical theory into the real world students live in.

What seems to be even more necessary, according to Masingila et al. (1996), is the process of transfer from school teaching into real life, as they mention that the individuals need the school experiences, but even more outside of it, in everyday life, in order to help learning have real meaning. Fuchs et al. (2002) agree and they stress that children learn better when they comprehend and are aware of what they learn and why they learn it through real life situations.

Primary and middle education curricula place great emphasis to the proportional relations that form a basic model with which we can easily and quickly approach various problematic situations. This model is the linear function $f(x) = ax$ (where $a \neq 0$) which can mathematically describe any proportional relation. This linear model is used, almost spontaneously, via various methods, in all situations that fulfil certain informal "conditions", leading however to many errors. This happens because the linear model is so powerful that creates a hallucination that there exists a proportion in a problematic situation, without this being essentially right. This phenomenon of wide use of the linear model $f(x) = ax$ to situations that are not proportional is mentioned in literature as «illusion of linearity», «linear trap», «linear obstacle» or «linear misconception» (De Bock, Verschaffel, & Janssens, 1998).

Many researches have tried to examine and to face student's tendency to handle not proportional problems as proportional. (Van Dooren, De Bock, Hessels, Janssens, and Verschaffel, 2005; Modestou & Gagatsis, 2007; Modestou, Gagatsis and Pitta-Pantazi, 2004).

The results of all these researches show that the linear model appears to be deeply rooted in the intuitional knowledge of students and to be used spontaneously, making the proportional approach look natural and unquestioned (De Bock et al., 2002). Modestou (2007) claims that the linear model, as it intervenes in the solution of proportional problems, is an epistemological obstacle for handling pseudo-proportion and she proposes the concept of meta-proportional awareness, which has a metacognitive character and concerns the skill to distinguish and solve no-proportional situations.

The research

Aim

In this paper we would like to see teacher-students' ability to transfer the proportional and inversely proportional quantities concept in real life and to mention examples of application. More precisely the questions posed are the following:

1. Are the students capable to mention a variety of everyday life examples where the concepts of proportional and inversely proportional quantities are applied?

2. Do they make mistakes in the examples they mention? That is to say do they mention examples where the situations do not describe proportional quantities?
3. Do they use a wide range of examples of everyday situations?
4. Is it easier for them to mention examples of proportional rather than inversely proportional quantities?
5. Does the ability to transfer the proportion concept in real life contexts depend on their mathematical knowledge or on their general performance in mathematics?

Methodology

During an official written intermediate student examination in mathematics course, the following exercise was given: *“You should mention all everyday life phenomena you know where proportional and inversely proportional quantities exist. In each of your examples of proportional quantities (apart from the cost, kilos, price of kilo) you should find the formula, the value table and the graph. In each example that you give you should describe the phenomenon precisely”*.

Seventy seven undergraduate students of 1st year from the Department of Sciences of Education participated in the research. Fifteen of them were boys and 62 were girls. The answers of students were recorded in Excel and were analyzed with SPSS.

Results

Answers for proportional quantities

Table 1: Right and wrong examples concerning proportional quantities

Number of right examples	Frequency of students	Percentage %	Number of wrong examples	Frequency of students	Percentage %
0	1	1,3	0	33	42,9
1	18	23,4	1	24	31,2
2	26	33,8	2	12	15,6
3	27	35,1	3	5	6,5
4	4	5,2	4	1	1,3
5	1	1,3	6	2	2,6
TOTAL	77	100,0		77	100,0

According to the table 1 presented above, less than half of the students (33 students, 42,9%) give examples of proportion without making mistakes. When we say mistakes we mean examples in which the quantities mentioned are not really proportional. The majority of students mentions two or three right examples. The average of right examples is 2,23. Eighteen students (23,4%) mention a right example, 26 students (33,8%) mention two right examples and 27 students (35,1%) mention three right examples.

The errors

Forty four students (57,1%) mention erroneous examples of proportion. The majority of these students mention one or two erroneous examples. The average of erroneous examples is 1,03. Twenty four students (31, 2%) mention an erroneous example, 12 students (15,6%) mention two erroneous examples.

The variety of examples

The students mentioned a total of 173 right examples of proportional quantities in which 23 different types of examples existed. Four were the most popular examples, 130 from the 173 that were totally given: Forty one students (53,2%) mentioned the example “hours of work - wage”. Thirty eight students (49,3%) mentioned “quantity of products - price”. This was an example also mentioned in the instructions for the exercise. Twenty nine students (37,6%) mentioned “travel distance - cost” and 22 students (28,5%) mentioned “distance - time”. Generally speaking, we can say that the themes were very limited in the examples mentioned by the students. Very few students mentioned examples from the area of geometry. The geometrical examples mentioned were: “increase of the side of a square or rectangle- increase of area”. In this example however the proportion is not described by the relation $y=ax$ but $y=a^2x$.

The students mentioned 79 wrong examples in which 58 different types of situations existed. The errors the students made were usually pseudo-proportional situations, that is to say situations where the quantities were increased or decreased simultaneously but no proportionally. For example: Eighteen students (23,3%) mentioned “increase of demand - increase of cost”, 7 students (9%) “Increase of length of the side of a square or rectangle - increase of area”, 8 students (6,5%) “increase of quantity of food - increase of weight”. We see that in the wrong examples of proportion the students use a wider variety of examples (58 types of examples in 79 answers) than they do in the right examples (23 types of examples in 173 answers). It seems that the students make mistakes easily when trying to give examples from everyday life that are different than usual.

Answers for inversely proportional quantities

Table 2: Right and wrong examples concerning inversely proportional quantities

Number of right examples	Frequency of students	Percentage %	Number of wrong examples	Frequency of students	Percentage %
0	8	10,4	0	40	51,9
1	21	27,3	1	23	29,9
2	38	49,4	2	8	10,4
3	10	13	3	2	2,6
			4	2	2,6
			5	2	2,6
TOTAL	77	100,0		77	100,0

In table 2 above we see that the 51,9% of students mention examples of inversely proportional quantities without being mistaken. Most students (38 students, 49,4%) mention two right examples, 21 students (27,3%) mention one right example and 10 students (13%) mention three right examples. On average, they mention 1,65 right examples of inversely proportional quantities.

The errors

Thirty seven students (48,1%) mention examples of inversely proportional quantities which are wrong. Most students that make a mistake mention one or two wrong examples. Twenty three students (29,9%) mention one wrong example and 8 students (10,4%) mention two wrong examples. Also 8 students (10,4%) cannot mention any example at all for inverse proportion.

The variety of examples

In total, the right examples of inversely proportional quantities mentioned by the students were 127, but there were only 9 different types of examples. Three were the most popular (118 out of 127): Fifty three students (68,8%) mentioned the example “Increase of car speed - reduction of time needed”. When the distance is the same. Forty eight students (62,3%) mentioned the example “Increase of number of workers - Reduction of time to complete the work” and 17 students (22%) mentioned the geometrical example “Increase of length of the rectangle side - Reduction of width”. When the area remains the same. We therefore see that the majority of students propose very limited range of examples on the concept of inversely proportional quantities. These situations are limited in the three examples above.

There were 63 wrong examples, which included 50 different situations, while in the 127 right examples there were only 9 different situations. Therefore we could say that, for the inversely proportional as well as for the proportional quantities, students make lots of mistakes when they try to avoid the cliché examples by giving their own examples from everyday life.

The most frequent wrong situation mentioned by 17 students (22%), concerned the issue of offer and the price of products: “Increase of offer - reduction of product price” or “Increase of product price- reduction of demand”. Certain other remarkable wrong examples are: “Increase of age - reduction of output”, “Increase of quantity - reduction of quality”, “Increase of production - reduction of natural resources”, etc.

Comparison between examples of proportion and inverse proportion

The average of right examples of proportional quantities ($[M]=2,23$, $SD=0,95$) and inversely proportional quantities ($[M]=1,65$, $SD=0,83$) differ considerably ($t=4,45$ $DF=76$, $p=0,000$ double size). That means that the students mention more examples of proportional quantities than of inversely proportional. It is also interesting that there is not cross-correlation between the student answers in the two tasks (proportional and

inversely proportional examples), ($X^2 = 1,73$, $DF=1$, $p=0,18$). It seems that these two situations are not connected for the students.

Comparison between mathematical knowledge on proportion and the ability to create examples

The ability of students to mathematically handle proportional quantities was examined by answering the following question:

“For one of the examples with proportional quantities (apart from the cost, kilos, price of kilo) you should find the formula, the value table and the graph”.

At this mathematical task students performed really well: 92,2% of the students wrote the right formula, 81,8% the value table and 89,6% the graph. 77,9% of the students gave the right answers for all three things (formula, table and graph).

We compare student success in the three mathematical tasks with the success in mentioning examples of proportional quantities ($X^2 = 0,51$, $DF=1$, $p=0,47$), or with the success in mentioning examples of inversely proportional quantities ($X^2 = 0,79$, $DF=1$, $p=0,37$), or with the simultaneous success in both proportional and inversely proportional quantities examples ($X^2 = 1,30$, $DF=1$, $p=0,25$). We can see that the performance of students in mathematical task is not connected with the success in mentioning examples of proportional or inversely proportional quantities neither with the success in finding examples of both situations.

According to the final semester evaluation in this mathematic course, where the intermediary examination but also the final examination was included, we divided students in two groups: in those that had good performance in the course and in those that did not.

Below the final performance of students in mathematics is compared with:

- the simultaneous success in the three questions of the mathematical task given (formula, table, graph) ($X^2 = 8,60$, $DF=1$, $p=0,003$)
- The success in mentioning examples of proportional quantities ($X^2 = 1,56$, $DF=1$, $p=0,21$)
- The success in mentioning examples of inversely proportional quantities ($X^2 = 0,11$, $DF=1$, $p=0,73$)
- The simultaneous success in mentioning examples of proportional and inversely proportional quantities ($X^2 = 0,34$, $DF=1$, $p=0,55$).

It's evident that there is a statistically important correlation between the final performance of students in the mathematics course and the success in answering the questions of mathematic task on proportion given to them. On the contrary there is not correlation between the performance of students in the mathematics course and the success in finding examples of proportional or inversely proportional quantities as well as the simultaneous success in mentioning proportional and inversely proportional quantities examples. Based on these findings we can conclude that the ability of students to connect their mathematical knowledge on proportion with examples from

everyday life does not seem to correlate with their general ability in maths. That means that students who are good at mathematics and understand proportion are not supposed to be able to find right examples of proportion in real life. And vice versa, students that do not perform well in mathematics and in proportion are not supposed to be unable to find right examples of proportion in real life

Conclusion

According to the results presented so far we can conclude that the sample of prospective teachers examined during their second year in university, cannot transfer the concept of proportion and give examples from everyday situations, even if they are familiar and they understand proportion as a mathematical concept. More specifically, these students when asked to provide with examples of everyday routine concerning proportional and inversely proportional situations, they use very limited range of examples that are classic and taught. When they try to give their own examples from everyday life they are mistaken by pseudo-proportion for proportional and inversely proportional quantities. This means that they consider proportional the quantities which are simply increased and decreased simultaneously and inversely proportional the quantities which are increased and decreased inversely.

Students are capable to propose much more right examples of proportional quantities rather than inversely proportional. It seems that finding right examples of proportional quantities and inversely proportional quantities are not related situations for the students. Also not related situations seem to be, the students' ability to mathematically handle proportion efficiently or to perform well in mathematics and the ability to find examples of proportional and inversely proportional quantities and to connect these concepts with the reality.

This shows that prospective teachers of our sample have two unconnected abilities, mathematical knowledge on the one hand and application of this knowledge in reality on the other. This means that the transfer of mathematical knowledge in reality is not easy.

Teachers, when teaching mathematics, should be capable to transfer mathematical concepts in real life, in rich and meaningful contexts for the students. Therefore prospective maths teachers should perhaps receive special teaching of many examples and applications of mathematic concepts in reality during their studies.

References

- Boaler, J. (1993). Encouraging the transfer of “school” mathematics to the “real world” through the integration of process and content, context and culture. *Educational Studies in Mathematics*, 25, 341-373.
- De Bock, D., Van Dooren, W., Janssens, D., & Verschaffel, L. (2002). Improper use of linear reasoning: An in-depth study of the nature and the irresistibility of secondary school students' errors. *Educational Studies in Mathematics*, 50, 311-314.

- De Bock, D., Verschaffel, L., & Janssens, D. (1998). The predominance of the linear model in secondary school students' solutions of word problems involving length and area of similar plane figures. *Educational Studies in Mathematics*, 35, 65-85.
- Evans, J. (2000). The transfer of mathematics learning from school to work not straightforward but not impossible either!, In Bessot & Ridway (eds.), *Education for mathematics in the workplace*, United States: Kluwer Academic Publishers, 5-15.
- Fuchs, L.S., Fuchs, D., Hamlett, C.L., & Appleton, A.C. (2002). Explicitly teaching for transfer: effects on the mathematical problem solving performance of students with mathematics disabilities. *Learning Disabilities Research & Practice*, 17 (2), 90-106.
- Hammer, D., Elby, A., Scherr, R.E., & Redish, E.F. (2005). Resources, Framing, and Transfer. In Mestre, J.P. (ed.), *Transfer of Learning from a Modern Multidisciplinary Perspective*, p.p. 90-91. Information Age Publishing Inc: United States.
- Hung, D.V.L. (2000). Some insights into the generalizing of mathematical meanings. *Journal of Mathematical Behavior*, 19, 63-82.
- Isaacs, A. C., Carroll, W. M., & Bell, M. (1998). A research-based curriculum: The research foundations of the UCSMP Everyday Mathematics curriculum. Chicago: UCSMP. [Available online at <http://everydaymath.uchicago.edu/educators/references.shtml>.]
- Lobato, J. and Siebert, D. (2002). Quantitative reasoning in a reconceived view of transfer. *Journal of Mathematical Behavior*, 21, 87-116.
- Lemire, D. (2002). Commentary: Math problem solving and mental discipline-the myth of transferability. *Journal of College Reading and Learning*, 32 (2), 229-238.
- Lemonidis Ch. (2005). Les mathématiques de la nature et de la vie: une conception pour l'enseignement des mathématiques. Présentation d'un exemple extrait de la formation des enseignants. Colloque COPIRELEM 30, 31- Mai, Strasbourg 2005.
- Masingila, J.O., Davidenko, S., & Prus-Wisniowska, E. (1996). Mathematics learning and practice in and out of school: a framework for connecting these experiences. *Educational Studies in Mathematics*, 31, 175-200.
- Modestou, M., & Gagatsis, A. (2007). Students' improper proportional reasoning: A result of the epistemological obstacle of "linearity". *Educational Psychology*, 27 (1), 75-92.
- Modestou, M., Gagatsis, A., Pitta-Pantazi, D. (2004). Students' improper proportional reasoning: The case of area and volume of rectangular figures. In M. J. Hoines & A. B. Fuglestad (Eds.), *Proceedings of the 28th Conference of the International*

Group for the Psychology of Mathematics Education (Vol. 3, pp. 345-352). Bergen: Norway.

- Μοδεστίνια, Μ., (2007). *Μαθηματική αναλογική σκέψη: Ένα πολυδιάστατο γνωστικό και μεταγνωστικό μοντέλο*. Διδακτορική διατριβή. Πανεπιστήμιο Κύπρου. Τμήμα Επιστημών της Αγωγής.
- Pugh, K.J., & Bergin, D.A. (2005). The effect of schooling on students' out-of-school experience. *Educational Researcher*, 34 (9), 15-23.
- Royer, J.M., Mestre, J.P., & Dufrense, R.J. (2005). Framing the transfer problem. In Mestre, J.P. (ed.), *Transfer of Learning from a Modern Multidisciplinary Perspective*, p.p. vii-xxvi. Information Age Publishing Inc: United States.
- Stanic, G.M.A., & Lester, F.K. (1989). Mathematical problem solving in and out of school. *Arithmetic Teacher*, 37 (3), 33-35.
- Van Dooren, W., De Bock, D., Hessels, A., Janssens, D., & Verschaffel, L. (2005). Ups and downs' is students' over-reliance on proportional methods. *Cognition and Instruction*, 23 (1), 57-86.

CHAPTER 4:

Problem Solving in Mathematics Education



An ICT environment to assess and support students’ mathematical problem-solving performance in non-routine puzzle-like word problems¹

Angeliki Kolovou*
Marja van den Heuvel-Panhuizen*#
Arthur Bakker*
Iliada Elia^x

*FIsme, Utrecht University, the Netherlands
#IQB, Humboldt University Berlin, Germany
^xDepartment of Education, University of Cyprus

Abstract

This paper reports on a small-scale study on primary school students’ problem-solving performance. In the study, problem solving is understood as solving non-routine puzzle-like word problems. The problems require dealing simultaneously with multiple, interrelated variables. The study employed an ICT environment both as a tool to support students’ learning by offering them opportunities to produce solutions, experiment and reflect on solutions, and as a tool to monitor and assess the students’ problem solving processes. In the study, 24 fourth-graders were involved from two schools in the Netherlands. Half of the students who belonged to the experimental group worked in pairs in the ICT environment. The analysis of the students’ dialogues and actions provided us with a detailed picture of students’ problem solving and revealed some interesting processes, for example, the bouncing effect that means that the students first come with a correct solution and later give again an incorrect solution. The test data collected before and after this “treatment” did not offer us a sufficient basis to draw conclusions about the power of ICT environment to improve the students’ problem-solving performance.

Introduction

Problem solving is a major goal of mathematics education and an activity that can be seen as the essence of mathematical thinking (Halmos, 1980; NCTM, 2000). With problems tackled in problem solving typically defined as non-routine (Kantowski, 1977), it is not surprising that students tend to find mathematical problem solving challenging and that teachers have difficulties preparing students for it. Despite the growing body of research literature in the area (Lesh & Zawojewski, 2007, Lester & Kehle, 2003,

¹ Paper presented in TSG19 at ICME11, 6-13 July, 2008

Theme (d): *Research and development in problem solving with ICT technology*

Schoenfeld, 1985), there is still much that we do not know about how students attempt to tackle mathematical problems and how to support students in solving non-routine problems.

In order to get a better understanding of Dutch primary school students' competences in mathematical problem solving, the POPO study started in 2004. In this study, 152 fourth-grade students who are high achievers in mathematics were administered a paper-and-pencil test on non-routine problem solving. In a few items, students were asked to show their solutions strategies. The results were disappointing. Students did not show a high performance in problem solving, despite their high mathematics ability (Van den Heuvel-Panhuizen, Bakker, Kolovou, & Elia, in preparation). Although the students' scribbling on the scrap paper gave us important information about their solution strategies, we were left with questions about their solution processes. Moreover, after recognizing that even very able students have difficulties with solving the problems, we wondered what kind of learning environment could help students to improve their problem solving performance. The POPO study thus yielded a series of questions. To answer these questions we started the iPOPO study which – in accordance with the two main questions that emerged from the POPO study – implied a dual research goal.

First, the iPOPO study aimed at gaining a deeper understanding of the primary school students' problem solving processes, and, second, it explored how their problem-solving skills can be improved. For this dual goal of assessing and teaching, the study employed ICT both as a tool to support students' learning by offering them opportunities to produce solutions, experiment and reflect on solutions, and as a tool to monitor and assess the students' problem solving processes. In particular, we designed a dynamic applet called *Hit the target*, which is based on one of the paper-and-pencil items used in the POPO study. Like several of these items, it requires students to deal with multiple, interrelated variables simultaneously and thus prepares for algebraic thinking.

This paper focuses on the following two research questions: Which problem-solving strategies do fourth-grade students deploy in this *Hit the target* environment? Does this ICT environment support the students' problem-solving performance?

Theoretical background

Mathematical problem solving

The term “problem solving” is used for solving a variety of mathematical problems, ranging from real-life problems to puzzle-like problems. Our focus is on the latter. We consider problem solving as a cognitive activity that entails strategic thinking, and that includes more than just carrying out calculations. An episode of problem solving may be considered as a small model of a learning process (D'Amore, & Zan, 1996). In problem solving, the solution process often requires several steps. First the students have to unravel the problem situation. Subsequently, they have to find a way to solve the problem by seeking patterns, trying out possibilities systematically, trying special cases, and so on.

An ICT environment and students' non-routine puzzle-like mathematical problem-solving

While doing this they have to coordinate relevant mathematical knowledge, organize the different steps to arrive at a solution and record their thinking. In sum, in our view problem solving is a complex activity that requires higher order thinking and goes beyond standard procedural skills (cf., Kantowski, 1977).

An example of a mathematical problem used in the POPO study is shown in Figure 1. Someone who knows elementary algebra might use this knowledge to find the answer to this problem by, for example, solving the equation $2x - 1(10 - x) = 8$. Fourth-grade students, however, have not yet learned such techniques, but can still use other strategies such as systematic listing of possible solutions or trial and error. Grappling with such problems might be a worthwhile experiential base for learning algebra in secondary school (cf., Van Amerom, 2002).

Quiz

In a quiz you get two points each time an answer is correct.
In case a question is not answered or the answer is false one point is subtracted from the score.
The quiz contains 10 questions.
Tina received 8 points in total.
How many questions did Tina answer correctly?

 **Answer** _____

 **Show how you found your answer**

Figure 1: Problem used in the POPO Study

Within the complexity that characterizes problem-solving activity, D'Amore and Zan (1996) identify the involvement of three interrelated discrete variables, as follows: the subject who solves the task; the task; and the environment in which the subject solves the task. This study primarily focuses on the third variable, referring to the conditions, which may help a subject to improve his problem solving abilities.

The research questions stated in Section 1 address two different aspects that are closely related: monitoring learning and supporting that learning. We have chosen to use ICT for both of these aspects, because – as Clements (1998) recognized – ICT (1) can provide students with an environment for doing mathematics and (2) can give the possibility of tracing the students' work.

ICT as a tool for supporting mathematical problem solving

A considerable body of research literature has shown that computers can support children in developing higher-order mathematical thinking (Suppes, 1966; Papert, 1980; Clements &

Meredith, 1993; Sfard & Leron, 1996; Clements, 2000; Clements, 2002). Logo programming, for example, is a rich environment that elicits reflection on mathematics and one's own problem-solving (Clements, 2000). Suitable computer software can offer unique opportunities for learning through exploration and creative problem solving. It can also help students make the transition from arithmetic to algebraic reasoning, and emphasize conceptual thinking and problem solving. According to the Principles and Standards of the National Council of Teachers of Mathematics (NCTM, 2000) technology supports decision-making, reflection, reasoning and problem solving.

Among the unique contributions of computers is that they also provide students with an environment for testing their ideas and giving them feedback (Clements, 2000). In fact, feedback is crucial for learning and technology can supply this feedback (NCTM, 2000). Computer-assisted feedback is one of the most effective forms of feedback because "it helps students in building cues and information regarding erroneous hypotheses"; thus it can "lead to the development of more effective and efficient strategies for processing and understanding" (Hattie & Timperley, 2007, p.102). More generally, computer-based applications can have significant effects on what children learn because of "the computer's capacity for simulation, dynamically linked notations, and interactivity" (Rochelle, Pea, Hoadley, Gordin, & Means, 2000, p. 86).

This learning effect can be enhanced by peer interaction. Pair and group work with computer software can make students more skilful at solving problems, because they are stimulated to articulate and explain their strategies and solutions (Wegerif & Dawes, 2004). Provided there is a classroom culture in which students are willing to provide explanations, justifications, and arguments to each other, we can expect better learning.

ICT as a window onto students' problem solving

Several researchers have emphasized that technology-rich environments allow us to track the processes students use in problem-solving (Bennet & Persky, 2002). ICT can provide mirrors to mathematical thinking (Clements, 2000) and can offer a *window* onto mathematical meaning under construction (Hoyles & Noss, 2003, p. 325). The potential of computer environments to provide insight into students' cognitive processes makes them a fruitful setting for research on how this learning takes place.

Because software enables us to record every command students make within an ICT environment, such registration software allows us to assess their problem solving strategies in more precise ways than can paper-and-pencil tasks. Therefore, computer-based tasks as opposed to conventional paper-and-pencil means have received growing interest in the research literature for the purposes of better assessment (Clements 1998; Pellegrino, Chudowsky, & Glaser, 2001; Bennet & Persky, 2002; Burkhardt & Pead, 2003; Threlfall, Pool, Homer, & Swinnerton, 2007; Van den Heuvel-Panhuizen, 2007).

Where early-generation software just mimicked the paper-and-pencil tasks, recent research shows that suitable tasks in rich ICT environments can also bring about higher-order problem solving. For example, Bennet and Persky (2002) claimed that technology-rich environments tap important emerging skills. They offer us the opportunity to describe performance with something more than a single summary score.

An ICT environment and students' non-routine puzzle-like mathematical problem-solving

Furthermore, a series of studies indicated that the use of ICT facilitates the assessment of creative and critical thinking by providing rich environments for problem solving (Harlen & Deakin Crick, 2003).

By stimulating peer interaction we also expect that students will articulate more clearly their thinking than when working individually. Thus, student collaboration has a twofold role: it helps them shape and broaden their mathematical understandings and it offers researchers and teachers a nicely bounded setting in order to observe collaboration and peer interaction (Mercer & Littleton, 2007).

Method

Research design and subjects

The part of the iPOPO study described in this paper is a small-scale quasi-experiment following a pre-test-post-test control group design. In total, 24 fourth-graders from two schools in Utrecht participated in the study. In each school, 12 students who belonged to the A level according to the Mid Grade 4 CITO test – in other words to the 25% best students according to a national norm – were involved. Actually, the range of the scores that correspond to level A of the Mid Grade 4 CITO test is between 102 and 151 points. In both schools, the average mathematics CITO score of the class was A and the average “formation weight” of the class and the school was 1. This means that the students were of Dutch parentage and came from families in which the parents had at least secondary education. First, of each school six students were selected for the experimental group. Later on, the group of students was extended with six students to be in the control group. These students also belonged to the A level, but, unfortunately, their average score was lower than that of the experimental group. The teacher obviously selected the more able students first.

An ICT environment was especially developed for this study to function as a treatment for the experimental group. Before and after the treatment, a test was administered as pre-test and post-test. The control group did the test also two times, but did not get the treatment in between. The quasi-experiment was carried out in March-April 2008. The complete experiment took about four weeks: in the first week the students did the test, in the second week the experimental group worked in the ICT environment and in the fourth week the students did again the test.

Pre-test and post-test

The test that was used as pre-test and post-test was a paper-and-pencil test consisting of three non-routine puzzle-like word problems, titled Quiz (see Figure 1), Ages, and Coins. The problems are of the same type and require that the students deal with interrelated variables. The test sheets contain a work area on which the students had to show how they found the answers. The students' responses were coded according to a framework that was developed in our earlier POPO study. The framework covers different response

characteristics including whether the students gave specific strategy information, how they represented that strategy and what kind of problem-solving strategies they applied.

Applet used as treatment

The treatment consisted of a Java applet called *Hit the target*.² It is a simulation of an arrow shooting game. The screen shows a target board, a score board featuring the number of gained points, and the number of hit and missed arrows, a frame that contains the rules for gaining or loosing points, and an area in which the number of arrows to be shot can be filled in. A hit means that the arrow hits the yellow circle in the middle of the target board; then the arrow becomes green. A miss means that the arrow hits the gray area of the board; in that case, the arrow becomes red.

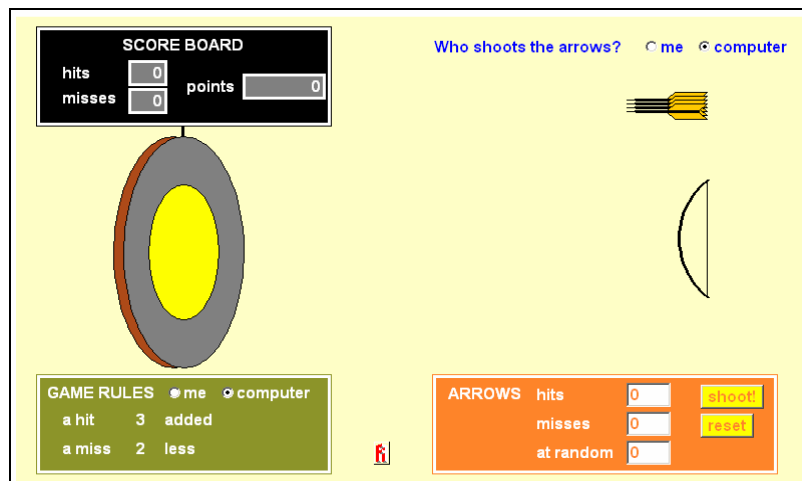

Figure 2: Screen view of applet in the computer-shooting mode

The applet has two modes of shooting: a player shoots arrows by him or herself or lets the computer do the shooting (see Figure 2). In case the player shoots, he or she has to drag the arrows to the bow and then draw and unbend the bow. The computer can do the shooting if the player selects the computer-shooting mode and fills in the number of arrows to be shot. Regarding the rules for gaining points there are also two modes: the player determines the rules or the computer does this. The maximum number of arrows is 150 and the maximum number of points the player can get by one shot is 1000.

As the player shoots arrows or lets the computer do so, the total score on the scoreboard changes according to the number of arrows shot and the rules of the game. The player can actually see on the scoreboard how the score and the number of hits and misses change during the shooting. The player can also remove arrows from the target board, which is again followed by a change in the total score. When the player wants to start a new shooting round, he or she must click on the reset button. The player can change the shooting mode or the rules of the game at any time during the game.

² The applet has been programmed by Huub Nilwik.

The aim of the applet is that the students obtain experience in working with variables and realize that the variables are interrelated (see Figure 3); a change in one variable affects the other variables. For example, if the rules of the game are changed, then the number of arrows should be also changed to keep the total points constant.

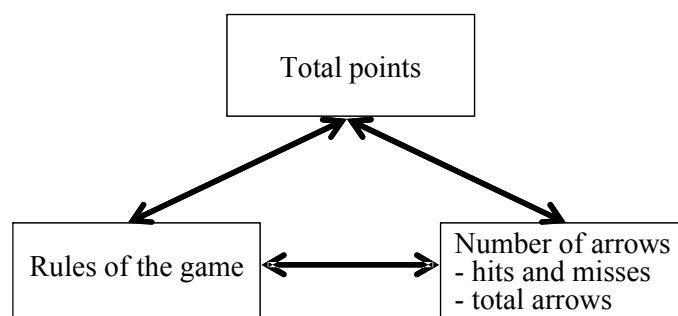

Figure 3: Variables involved

The 12 students of the experimental group worked for about 30 minutes in pairs with the applet. The pairs were chosen by the researcher in such a way that all of them would have about the same average CITO score and consisted of a boy and a girl. The dialogue between the students and their actions on the applet were recorded by Camtasia software, which captures the screen views and the sound in a video file. Scrap paper was also available to the students. Before the students started working, it was explained to them that they should work together, use the mouse in turns, explain their thinking to each other, and justify their ideas.

The work with the applet started with five minutes of free playing in which the students could explore the applet. Then, they had to follow a pre-defined scenario containing a number of directed activities and three questions (see Table 1). The first two questions (A and B) are about the arrows while the rules of the game and the gained points are known. In the third question (C), which consists of two parts, the rules of the game are unknown.

Table 1: Questions in the pre-defined scenario

Arrows	Rules	Gained points
A. How many hits and misses?	Hit +3 points, miss –1 point	15 points
B. How many hits and misses? 15 hits and 15 misses	Hit +3 points, miss +1 point	15 points
	C1. What are the rules? C2. Are other rules possible to get the result 15 hits-15 misses-15 points?	15 points

The directed activities were meant to assure that all the students had all the necessary experiences with the applet. During these activities, the students carried out a number of assignments in order to become familiar with the various features of the applet: the player-shooting mode, the computer-shooting mode, the rules of the game, and the total score. First, the students had to shoot one arrow, followed by shooting two arrows and then a few more, in order to get five arrows on the target board. Their attention was then drawn to the scoreboard; they had five hits and zero misses and their total score was zero since the rules of the game had been initially set to zero. After that, the rules were changed so that a hit meant that three points were added. Then, the students had to shoot again five arrows in both shooting modes, each resulting in a total score of 15 points. Afterward, the rule was changed again. A miss then meant that one point had to be subtracted. At this point, Question A was asked, followed by Questions B and C.

Results

The students' problem-solving strategies in the ICT environment

All pairs were successful in answering the Questions A, B, and C. The solutions were found based on discussions and sharing ideas for solutions. In all cases, explanations were provided and the talk between the students stimulated the generation of hypotheses and solutions. However, some students provided more elaborate explanations and suggested more successful problem-solving strategies than others.

In order to identify the problem-solving strategies the students applied, we analyzed all dialogues between the students. In this paper, however, we will only discuss our findings with respect to Questions C1 and C2, which triggered the richest dialogues.

Characteristic for Question C is that the number of hits and misses, and the number of points were given, but that the students had to find the rules. All pairs were able to answer Questions C1 and C2, and most of them could generalize to all possible solutions ("It is always possible if you do one less"), albeit on different levels of generalization. The Tables 2 and 3 show which strategies the pairs used when solving Questions C1 and C2. Each pair of students is denoted with a Roman numeral. Pairs I, II, and III belong to school A, while Pairs IV, V, and VI belong to school B.

When answering Question C1 (see Table 2), four out of the six pairs directly came up with a correct solution. Pair VI found the correct solution in the third trial. The most interesting strategy came from Pair IV. This pair found the correct solution in the second trial. The pair started with a canceling-out solution (+1 -1) resulting in a total score of zero and then changed the solution to get 15 points in total.

Table 2: Problem-solving strategies when solving C1

Strategy		Pairs					
		I	II	III	IV	V	VI
		Average CITO score per pair					
		111	111	114	11	111	10
					0		7
1a	Directly testing a correct solution (+2 -1 or +1 +0)	1*	1	1		1	
2a	Testing incorrect <i>canceling-out solution</i> (+1 -1)				1		
2b	Testing other incorrect solution(s)						1
3	Adapting the rules of the game until a correct solution is reached				2		2
Number of trials		1	1	1	2	1	3

* The numbers in the cell indicate the order in which the strategies were applied

Table 3 shows that having found a correct solution in C1 did not mean that the students had discovered the general principle (or the correct solution rule) of getting “15 hits-15 misses-15 points”. Even after finding the correct solution rule and generating a series of correct solutions, some students tested wrong solutions again (we could call this the “bouncing effect”). Perhaps they were not aware that there is only one correct solution rule; the difference between the number of points added for every hit and the number of points subtracted for every miss (or vice versa) should be 1, or the difference between the number of hit-points and miss-points should be 15 points. The highest level of solution was demonstrated by Pair VI, who recognized that the difference between the points added and the points subtracted should be 15 (and that explains why the difference between the number of points added for every hit and the number of points subtracted for every miss – or vice versa – should be 1). A clever mathematical solution came from the Pairs I and II. These students just used the correct solution to C1 in the reverse way to get the required result of 15 points in total.

Besides strategies that directly or indirectly lead to a correct solution or rule, some other characteristics were found in the solution processes (see Table 4). Four pairs altered or ignored information given in the problem description. It is noteworthy that during subsequent attempts to answer Question C2, some students insisted on keeping the rules constant and changing the number of hits and misses in order to get a total of 15 points. Pair V, for example, changed the problem information (15 hits and 15 misses) and started C2 with trying out the solution 1 hit is 15 point added and 1 miss is 15 points subtracted. The total score then became zero; subsequently, they set the number of hits to 30 and the number of misses to 15, which resulted into a high score. Even though at that point the researcher repeated the correct problem information, the students ignored it persistently. In their third attempt, they changed the number of hits and misses to 1 and 0 respectively and the total score became 15 instead of the reverse (15 hits and 15 misses resulting in 15 points). Only when the researcher repeated the

question they considered the correct information and tried out the solution +4 –2 with 15 hits and 15 misses.

Table 3: Problem-solving strategies when solving C2

Strategy		Pairs					
		I	II	III	IV	V	VI
		Average CITO score per pair					
		111	111	114	11	111	10
					0		7
4a	Repeating the correct solution to C1					2	
4b	Reversing the correct solution to C1 to find another correct solution (–1 +2 or –0 +1/+0 +1)	1*	1/3				
5a	Generating a correct solution rule based on testing of (a) correct solution(s) for which the difference between the number of points added for every hit and the number of points subtracted for every miss (or vice versa) is 1	2	4	6	1	4	
5b	Generating a correct solution rule based on understanding that the difference between hit-points and miss-points is 15						1
5c	Generating a general correct solution rule (“the difference of 1 also applies to 16-16-16”)			8			
6	Testing more correct solutions from a correct solution rule	3		7	2		2
2b	Testing other incorrect solution(s)	4	2	1/3/ 5		1/3/ 5	
7	Generating an incorrect solution rule (keeping ratio 2:1 or using rule +even number –odd number) based on correct solution(s)			2/4			

* The numbers in the cell indicate the order in which the strategies were applied

However, the total score was 30 points and they suggested doubling the number of misses to 30 so that the number of total points would be halved. This is clearly an example of a wrong adaptation. Another example is from Pair VI. After having +3 and –1 as the rule of the game, resulting in a total of 30 points, the students change the number of hits into 10 in order to get 15 points as the result but forgetting that the number of hits should be 15.

Table 4: Other characteristics of the solution processes

Characteristics	C1						C2					
	Pairs						Pairs					
	I	II	III	IV	V	VI	I	II	III	IV	V	VI
Altering or ignoring information			X				X	X				X
Exploring large numbers (≥ 1000)								X	X	X	X	X

Another characteristic of the solution processes was testing rules including large numbers. Four of the six pairs tried out numbers bigger than 1000. These explorations all took place when answering the second part of Question C. The students found this working with large numbers quite amusing, since they then could get a large amount of total points. That the students worked with numbers larger than 1000 was quite remarkable, because it was not possible to fill in numbers of this size in the applet. Consequently, the students had to work out the results mentally. It is also worth noting that some students understood that one could go on until one million or one trillion (Pair IV). This means that several students knew that there are infinite solutions, as it was made explicit by one pair (see Pair II). Furthermore, most of the students used whole numbers and no one used negative numbers. In one occasion, a student (from Pair II) suggested adding $1\frac{1}{2}$ points for a hit, but the applet does not have the possibility to test solutions with fractions or decimals.

Observing the students while working on the applet revealed that the students demonstrated different levels of problem-solving activity. For example, there were students that checked the correctness of their hypotheses by mental calculation, while others just tried out rules with the help of the applet. None of them questioned the infallibility of the applet; when they used the applet after they had found out that a rule was wrong, they did this to make sure that they were *really* wrong. Furthermore, the students also showed differences in the more or less general way in which they expressed their findings. One of the students articulated that the general rule “a hit is one point more (added) than the number of points (subtracted) by a miss” also applies to other triads such as 16 hits-16 misses-16 points and in general to all triads of equal numbers.

To conclude this section about the ICT environment, we must say that observing the students while working with the applet gave us quite a good opportunity to get closer to the students' problem-solving processes.

Does the ICT environment support the students' problem-solving performance?

In this section, we discuss the results from the pre-test and the post-test in the experimental and control group. Figure 4 shows the average number of correct answers per student in both groups in school A and school B.

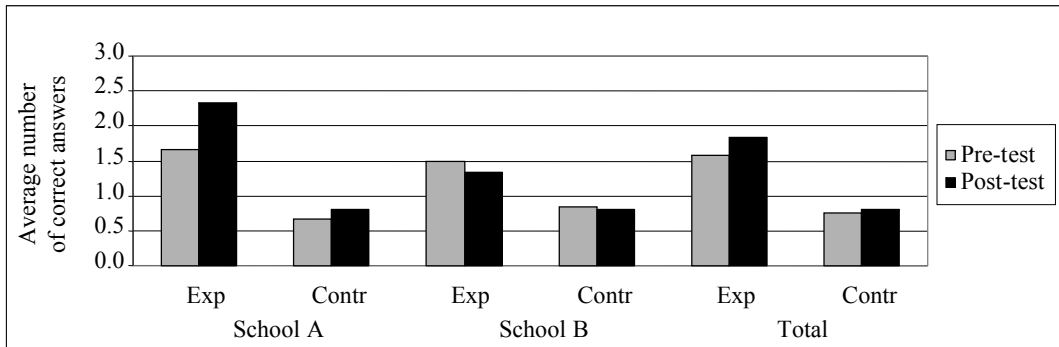

Figure 4: Average number of correct answers per student in the pre and the post-test in both groups

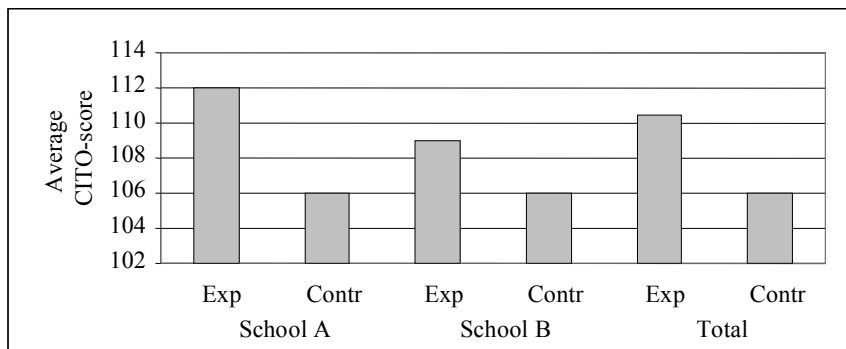

Figure 5: Average CITO score of the experimental and control group

As can be seen in Figure 4, if the group of students is taken as a whole, the experimental group gained slightly from the treatment. However, we have too few data to give a reliable answer to the research question. Only 12 students from school A and 12 students from school B were involved in this study and among these schools, the results were quite different. Only in school A, there is a considerable improvement in the scores of the post-test. Another issue is the mismatch between experimental and control group (see also Section 3.1). In both schools, the control group scored lower than the experimental group. This mismatch was more evident in school A. A plausible explanation for these differences could be that although all students had an A score in mathematics, the average CITO scores of the experimental group and the control group were different in school A and school B (see Figure 5).

In fact, the differences between the average CITO score of the experimental and control group in each school, presented in Figure 5, are similar to the differences between the average scores of these groups in the paper-and-pencil test. In school A, the control group has a lower CITO score than the experimental group. The same holds for school B, but there the difference is smaller than in school A.

Discussion

We started this study with two questions that emerged from the earlier POPO study. To investigate these questions, we set up, as a start, a small-scale study in which an ICT environment played a crucial role. The dialogues between the students and their actions when working in the ICT environment gave us a first answer to the first research question. The collected data provided us with a detailed picture of students' problem solving and revealed some interesting processes, for example, the bouncing effect and the making of wrong adaptations.

Our second question is difficult to answer. The sample size, and the number of the test items were not sufficient to get reliable results and the time we had at our disposal was not enough to gather and analyze more data. Moreover, the time that the experimental group worked in the ICT environment was rather limited to expect an effect. Despite these shortcomings, we decided to carry out a small-scale study in order to try out the test items and the ICT environment with a small group of students first.

Clearly, more data (more students, more schools and more problems) are needed to confirm or reject our conjecture that having experience with interrelated variables in a dynamic, interactive ICT environment leads to an improvement in problem solving performance. For this reason, we will extend our study to larger groups of students, involving students of higher grades and different mathematical ability levels as well. Moreover, to see more of an effect we will enlarge the working in the ICT environment substantially. In addition, we will extend the study by analyzing the students' problem-solving strategies when solving paper-and-pencil problems. Our experiences from the present study will serve as a basis for doing this future research.

References

- Bennett, R. E., & Persky, H. (2002). Problem solving in technology-rich environments. In C. Richardson (Ed.), *Assessing gifted and talented children* (pp. 19-33). London: Qualifications and Curriculum Authority.
- Burkhardt, H., & Pead, D. (2003). Computer-based assessment: a platform for better tests? In C. Richardson (Ed.), *Whither Assessment?* (pp. 133-148). London: Qualifications and Curriculum Authority, UK. Retrieved from <http://www.nottingham.ac.uk/education/MARS/papers/whither/index.htm>.
- Clements, D. H., & Meredith, J. S. (1993). Research on Logo: Effects and Efficacy. *Journal of Computing in Childhood Education*, 4(3-4), 263-290.
- Clements, D. H. (1998). Computers in Mathematics Education Assessment. In G. W. Bright & J. N. Joyner, *Classroom Assessment in Mathematics: Views from a National Science Foundation Working Conference* (pp. 153-159). Lanham, MD: University Press of America.

- Clements, D. H. (2000). From exercises and tasks to problems and projects. *Journal for Research in Mathematics Education*, 19(1), 9-47.
- Clements, D. H. (2002). Computers in Early Childhood Mathematics. *Contemporary Issues in Early Childhood*, 3(2), 160-181.
- D'Amore, B., & Zan, R. (1996). Italian research on problem solving 1988-1995. In A. Gagatsis & L. Rogers (Eds.), *Didactics and History of Mathematics* (pp. 35-51). Thessaloniki: Erasmus ICP-95-G-2011/11.
- Halmos, P. (1980). The heart of mathematics. *American Mathematical Monthly*, 87(7), 519-524.
- Harlen, W., & Deakin Crick, R. (2003). A systematic review of the impact on students and teachers of the use of ICT for assessment of creative and critical thinking skills. London: EPPI-Centre, Social Science Research Unit, Institute of Education, University of London. Retrieved from <http://eppi.ioe.ac.uk>.
- Hattie, J., & Timperley, H. (2007). The Power of Feedback. *Review of Educational Research*. 77(1), 81-112.
- Hoyles, C., & Noss, R. (2003). What can digital technologies take from and bring to research in mathematics education? In A. J. Bishop (Ed.), *Second International Handbook of Mathematics Education* (pp. 323-349). Dordrecht; Boston: Kluwer Academic Publishers.
- Kantowski, M. G. (1977). Processes Involved in Mathematical Problem Solving. *Journal for Research in Mathematics Education*, 8(3), 163-180.
- Lesh, R., & Zawojewski, J. S. (2007). Problem solving and modeling. In F. K. Lester (Ed.), *Second Handbook of Research on Mathematics Teaching and Learning* (Vol. 2, pp. 763-804). Charlotte, NC: Information Age Publishing.
- Lester, F. K., & Kehle, P. E. (2003). From problem solving to modeling: The evolution of thinking about research on complex mathematical activity. In R. Lesh & H. H. Doerr (Eds.), *Beyond Constructivism: Models and Modeling Perspectives on Mathematics Problem Solving, Learning and Teaching* (pp. 501-518). Mahwah, NJ: Erlbaum.
- Mercer, N., & Littleton, K. (2007). *Dialogue and the Development of Children's Thinking: a Sociocultural Approach*. London and New York: Routledge.
- National Council of Teachers of Mathematics (2000). *Principles and Standards for School Mathematics*. Reston, VA: Author.
- Papert, S. (1980). *Mindstorms: Children, Computers, and Powerful Ideas*. New York: Basic Books.
- Pellegrino, J. W., Chudowsky, N., & Glaser, R. (2001). *Knowing What Students Know: The Science and Design of Educational Assessment*. Washington, DC: National Academy Press.

An ICT environment and students' non-routine puzzle-like mathematical problem-solving

- Roschelle, J. M., Pea, R. D., Hoadley, C. M., Gordin, D. N., & Means, B. M. (2000). Changing how and what children learn in school with computer-based technologies. *The Future of children* 10(2), 76-101.
- Schoenfeld, A. H. (1985). *Mathematical Problem Solving*. New York: Academic Press.
- Sfard, A., & Leron, U. (1996). Just Give me a Computer and I will Move the Earth: Programming as a Catalyst of a Cultural Revolution in the Mathematics Classroom. *International Journal of Computers for Mathematical Learning*, 1(2), 189-195.
- Suppes, P., & Morningstar, M. (1969). Computer-assisted instruction. *Science* 166(903), 343-350.
- Threlfall, J., Pool, P., Homer, M., & Swinnerton, B. (2007). Implicit aspects of paper and pencil mathematics assessment that come to light through the use of the computer. *Educational Studies of Mathematics* 66(3), 335-348
- Van Amerom, B. A. (2002). *Reinvention of early algebra: developmental research on the transition from arithmetic to algebra*. Utrecht: CD-β Press, Center for Science and Mathematics Education, Utrecht University.
- Van den Heuvel-Panhuizen, M. (2007). Changes in purpose, content and format: Trends in assessment in mathematics education. In B. Choksi & C. Natarajan (Eds.), *The epiSTEME Reviews, Vol. 2, Research Trends in Science, Technology and Mathematics Education* (pp. 241-266). New Delhi, India: Macmillan.
- Van den Heuvel-Panhuizen, M., Bakker, A., Kolovou, A., & Elia I. (in preparation) *Mathematical problem solving by high achieving primary school students*.
- Wegerif, R., & Dawes, L. (2004). *Thinking and Learning with ICT. Raising Achievement in Primary Classrooms*. London and New York: Routledge Falmer.



Approaching the inequality concept via a functional approach to school algebra in a problem solving context

Petros Verikios & Vassiliki Farmaki

Department of Mathematics, University of Athens, Greece

Abstract

This paper is a part of wider study on teaching and learning of school algebra. We used a functional approach to school algebra in order to teach basic mathematical concepts, such as equation and inequality. In this paper we are interested with the inequality concept and our aim is to investigate if and how a functional approach can facilitate students to understand the inequality concept and to solve inequality problems. In order to examine these questions we analyze students' answers given during their problem solving processes at individual interviews. Results are encouraging and show that students who were taught these concepts via this approach can use function representations as problem solving strategies and they appear to prefer mainly the graphs and the values tables and secondly the symbolic representations in problem solving. Students could use one representation in order to minimize a disadvantage of another. In addition, they gave meaning to symbols, through the problem context, and developed important actions of inequality understanding.

Introduction

Equations and inequalities play an important role in mathematics. This paper deals mainly with *inequalities* which is a difficult subject for students and a subject scarcely considered till now by researchers in mathematics education (Boero and Bazzini, 2004). While there is enough research on equations, the same does not happen with inequalities (Sokolowski, 2000). In most countries (Greece included), inequalities are taught in secondary school as a subordinate subject (in relationship with equations), dealt with in a purely algorithmic manner. This approach implies a 'trivialisation' of the subject, resulting in a sequence of routine procedures, which are not easy for students to understand, interpret and control. As a consequence of this approach, students are unable to manage inequalities which do not fit the learned schemas (Boero & Bazzini, 2004; Tsamir, Almog & Tirosh, 1998). According to Sackur (2004, p 151) an important and indeed crucial question is the apparent similarity among finding the solutions of equations and of inequalities. Emphasis is given to formal algebraic methods and generally graphic heuristics are not exploited; and algebraic transformations are performed without care for the constraints derived from the fact that the inequality sign ($>$) does not behave like the equality sign ($=$) (Tsamir & Almog, 1999; Sackur, 2004). The NCTM Standards recommends that all students should learn to represent situations that involve (equations and) inequalities, and that

they should understand the meaning of equivalent forms of expressions, equations and inequalities and solve them fluently (NCTM, 2000). To put into practice these recommendations it is crucial to analyze students' ways of understanding of the concepts of equations and inequalities after a concrete didactical approach.

Theoretical framework

As many teachers and researchers point out, the presentation of algebra almost exclusively as the study of expressions and equations can pose serious obstacles in the process of effective and meaningful learning (Kieran, 1992). As a result, mathematics educators recommend that students use various *representations* from the very beginning of learning algebra (NCTM 2000). Using *verbal, numerical, graphical* and *algebraic* representations has the potential of making the process of learning algebra meaningful and effective (Friedlander & Tabach, 2001, p 173). Although each representation has its disadvantages, their combined use can cancel them out and prove to be an effective tool (Kaput, 1992). Ainsworth, Bibby and Wood (1998) mention two ways that multiple representations may promote learning; (a) it is highly probable that different representations express different aspects more clearly and that, hence, the information gained from combining representations will be greater than that which can be gained from a single representation, (b) multiple representations constrain each other, so that the space of permissible operators becomes smaller. Similarly, Duval (2002) suggests that a representation cannot describe fully a mathematical concept and each representation has different advantages, so the use of various representations for the same concept is at the core of mathematical understanding. But, Friedlander and Tabach (2001) point out, we cannot expect the ability to work with a variety of representations to develop spontaneously, therefore, when students are learning algebra, their awareness of and ability to use various representations must be promoted actively and systematically. Kieran (2004) points out “the positive role that graphical representations can play in helping students to better conceptualize the symbolic form of inequalities, as well as the pitfalls involved in attempting to apply to the solving of inequalities some of the transformational techniques employed with equations [...] Despite its foray into graphical representations, this same body of research has been quite narrow in emphasis with its almost exclusive focus on the manipulative/symbolic aspects of inequalities”.

Concerning the content and the teaching of mathematics, Klein (1945), a great mathematician, from the beginning of 20th century, had strongly supported the idea of introducing functions early in the secondary school as a basis for development of mathematics. Klein advocated the introduction of the notion of function “not as a new abstract discipline but as an organic part of the total instruction, starting slowly ... with simple and concrete examples ... [and] the teacher must take account of the psychic processes in the boy in order to grip his interest; and he will succeed only if he presents things in a form intuitively comprehensible. A more abstract presentation will be possible only in the upper classes”. Other researchers support this view, as Thorpe (1989) who supports that “functions are basic in algebra and in mathematics more general, so we do not teach functions in algebra, let's make functions the epicentre of

teaching of algebra” (p. 18), and Schwartz & Yerushalmy (1993) who point out that “the concept of function is central in mathematics [...] it is the fundamental object of algebra and it ought to be present with a variety of representations in teaching and learning of algebra from the beginning (1993, p. 41). We believe that function is pivotal, central and the synthesis of many topics students traditionally learns in isolation in elementary school. Functions are important in the development of mathematical knowledge and knowledge in other subject areas in school curriculum.

The research (Bednarz, Kieran & Lee, 1996; Stacey, Chick & Kendal, 2004) proposes various approaches in school algebra; between these, this that uses the multiple representations and extends the meaning of algebraic thinking is the functional approach. A functional approach assumes the function to be a central concept around which school algebra can be meaningfully organized. This means that representations of relationships can be expressed in modes suitable for functions and that the letter-symbolic expressions are one of these modes. Thus, algebraic thinking can be defined as the use of a variety of representations in order to handle quantitative situations in a relational way (Kieran 1996, p.275).

In this paper we research students’ understanding of inequality concept and its relation with equation concept, and more specifically we try to answer the following questions: which ways students, who were introduced to algebra via a functional approach in a problem solving context, (a) realized the conceptual transition from equation to inequality? (b) used multiple representations for problem solving strategies? (c) used multiple representations in order to control their solutions?

Method

The research has argued that the traditional approach to algebra (based on equation with an abstract and formal way) creates various obstacles to the students, in order to understand basic mathematic concepts as function, equation, inequality and to solve problems of linear equations and inequalities. Adopting a functional approach in a problem solving context we planned a research project (*reconceptualizing* of school algebra) which concerned linear equations and inequalities for novice student to school algebra. Our instructional design is constituted by (a) planning of activities; (b) realisation in a real conditions class (23 students), grade 8, in a public school of Athens (a course of 26 lessons); and (c) its evaluation; (see Farmaki, Klaoudatos, Verikios, 2004; Farmaki, Klaoudatos, Verikios, 2005; Verikios, Farmaki, 2006). The goals of our wider research were to examine if and in which level the students were capable to: develop a conceptual *comprehension* for variable, function, equation and inequality; to *connect* those concepts; *mathematize* a situation using function representations and use these representations for *solve* problems of linear equations and inequalities. In the Greek curriculum for the second class of 13⁺-year-old students in junior high school, equations precede the functions and in the students’ textbook they are found in two different chapters. The solution of equations $ax+b=c$ and $ax+b=cx+d$ is presented in a typical way, concentrating on symbol manipulations, while, as a final paragraph, the solution of the inequalities $ax+b<c$ and $ax+b<cx+d$ follows as a subor-

dinate subject (in relationship with equations). In functions' chapter the linear one of the form $y=ax+b$ is the main subject. So the students are taught to solve equation only with a typical algebraic way. The inequality is solved in a similar way as happens for the equation.

Our course replaced the course on equations and the one on functions in the curriculum. Initially, we taught intuitively the concept of function, giving accent to graphic representations. At the same time, we tried to expand the notion of function from its view of an abstract object to an understanding that functions describe real-world phenomena. While there was not formal teaching of definition of function, function notation (e.g. $y=3x-2$) and the notion of a relationship between a dependent and an independent variable is used. Algebraic letters stand primarily for variables and we restrict ourselves to use representations more as mathematical tools (and less as means of communication). Generally we viewed function from a coordinated perspective (Monoyiou and Gagatsis, 2007), that combines the algebraic and the graphical approach. The teaching was almost all set in the context of real world problems which were familiar to the students (Freudenthal, 1991), because young children understand the notion of a contingency relationship between two quantitative variables when they see this relationship demonstrated in a concrete, physical *context* (Piaget, Grize, Szeminska, & Bang, 1968) and students who were working with context problems are helped to 'relate things and to produce answers which make sense' (Bardini, Pierce & Stacey, 2004). The functional orientation enabled us to connect various problem situations to graphs, tables and letter-symbolic representations as well as to connect these representations to the notions of equation and inequality. In the beginning of the solution of a problem, attention was paid to the graphic representation of it, where x was seen as a variable rather than an unknown quantity. In this way the symbols as letters, lines or tables, acquired a meaning from the situational context of the problem. In contrary to traditional course that focuses on algebraic solutions of equations and inequalities, our algebra courses focuses on '*ways to solve a problem*' rather than '*the way to solve a problem*' so as to equip students with multiple solution strategies..

A functional approach to algebra with emphasis on multiple representations of concepts is drastically different from the traditional methods in which symbolic algebra is emphasized and the concepts are studied in isolation from one another. For many teachers this new approach to teaching is often complex and difficult. This is for several reasons. On the one hand, this new approach to content is drastically different from the "mathematics" they know and experienced as learners themselves. On the other hand, the instructional techniques are, for the most part, unfamiliar to them. Thus, a major challenge associated with reforming school algebra and this study is, between others, to help teachers to implement reformed algebra in their classrooms.

For evaluation of our research project we selected data in three different ways: from class observations, from works and tests given to students, and mainly from interviews; unstructured interviews were used in order to develop an explanation concerning student understanding. More concretely, eight students were interviewed indi-

vidually (four interviews every student) and asked to solve a related task in each interview, covering essentially all the subjects taught in the course. The interviews were audiotaped and the protocols were analyzed to document student conceptions. Our paper can be viewed on two levels: It can be considered as an overview of the course and also as a research report about the progress and the obstacles that students met under the specific course.

The tasks of interviews

The units, which the interviewer (1st author) gives to the students, begin with stories about a taxi and a parking. The cost of a route (distance) is set up as a function of how much kilometres it does, first in a table, on a graph and in a formula. The cost in the parking is set up as a function of how much hours the car will parking. Students graph the function and read various information related to the problem setting, from the graph. The given tasks, in the interviews, were the following:

The taxi problem: When we use a taxi we pay a standard charge 0.80€ and 0.30€ per kilometer. Questions: 1. If we pay y € for a route of x kilometers, express y as a function of x . Describe how you can construct the graph of this function. 2. Two friends, George and Tom, are in the center of Athens, in Omonia square. George takes a taxi for his house. He pays for this route 3.5€. How many kilometers is his house from Omonia square? 3. Tom takes also a taxi for his house. For this route, he gives the taxi driver 5€ and takes change. How many kilometres can be his house from Omonia square?

The parking problem: Mr. Georgiou goes by car every work day to the centre of Athens, where his office is located. Nearby there are two car parks. The first demands 4 euros to enter and 2 euros per hour. The second demands only 3 euros per hour. Mr. Georgiou does not have a regular timetable. So, his choice about where he parks his car depends on how many hours he will stay at his office. Questions: 1. Express the amount of money as a function of time for both car parks. Describe how you can construct the graphs of these functions. 2. For how many hours can he park his car and pay the same amount of money at each car park? 3. Which parking you believe that it is more economic for Mr Georgiou, in order to park his car?

We are interested for the answer to the last question of each problem. The students, working in the previous questions of the problems, already had constructed the model of the situation by the functions $y=0.3x+0.8$ (taxi), $y=2x+4$ and $y=3x$ (parking) or by their graphs, and had answered question 2, using a values table or a graph or solving an equation ($0.3x+0.8=3.5$ for the taxi and $0.3x+0.8=3.5$ for the parking). Both problems are formulated in such way that is facilitated a functional approach; but, the first is more instructive from the second, which is more open. Concerning the structure with regard to graphs the two problems are different. In taxi we have only a graph and it appears rather difficult for students to suppose the equation $y=5$ as the constant function and to compare the two graphs. In opposite, in parking we have two graphs that describe with a whole way the situation; so, students can compare the graphs as concern their positions. It should be noted that in the class less time was devoted for the inequality than for the equation and the students had not completely constructed a cognitive scheme for this concept. So, we can suppose that during the inter-

view the students were trying to develop and evolve an adequate cognitive scheme through problem solving for the inequality concept.

Data Analysis

Approaching the inequality $ax+b<c$ in a problem solving context

Via the **taxi problem** we can investigate the way that students approach the inequality of the form $ax+b<c$ using multiple representations. All the interviewed students realized the difference between the question 2, which is referred to equation, and 3. The situation context and more concretely the word *change* is *crucial* and constitutes a *bridge* from equation to inequality, as it appears from the students' answers. Precisely, we received the following answers:

Olivia: *we will proceed as before... $5=x \cdot 0.3+0.8$ based on formula $y=x \cdot 0.3+0.8$ with $y=5\text{€}$... ok, he did not pay **precisely** 5€, **almost** 5€.*

Helen: *he takes changes ... $5-y$... there are **a lot of** solutions.*

Sia: *it doesn't look to me like an equation, but more like an **inequality**, isn't it?*

Sotiris: *we know that he gave 5€... we don't know the final cost, it is hard, it is not as before, because it does not give us, e.g. 3.5€ ... the cost precisely.*

The situation context helped students to realize the difference between situations that from the expert's perspective, involve the concepts equation or inequality, respectively; as a result the students realised the first step to transition from equation to inequality. The students were encouraged to use any mode in order to solve the problem. When a student gave an answer to the question, the interviewer encouraged him to think of an alternative method. Only one student adopted from the beginning the algebraic way of solving, while all the others used the already constructed graph of the function $y=0.3x+0.8$; of them, two students used the values table. So the strategies used were: the values table, the graph, and the algebraic mode. Only Andrea, a performer above average, answered from the beginning to question with an algebraic way. She answered the question constructing the inequality $y<5$ and then the equivalent $x \cdot 0.30+0.80<5$, solving it without difficulty. Then, she was encouraged by the interviewer to provide an answer using the graph representation. There, she faced an obstacle concerning how to interpret the inequality $y<5$, as it appears in the following extract from her interview:

Andrea: *if we go up to some value less than 5 ... and continue in straight line with all the values until... [She brings a 'mental' line parallel to x-axis, beginning a little before 5, with her pencil] ... 12 appear [in x-axis].*

Interviewer: *can we also get to 12.5?*

Andrea: *yes, if we continue ... how to find it with **precision**?*

Interviewer: *up to what can we continue?*

Andrea: *up to 4.5 [she shows in the y-axis].*

Interviewer: *can we up to 4.9?*

Andrea: yes, and up to 4.9.

Interviewer: can we go to 5?

Andrea: ... no, because he took some change.

Then, based on her 'algebraic' answer, she observed that the value $x=14$ results for the value $y=5$, and she drew the suitable lines (figure 1), determining 14 on the x-axis and saying: 'to 5 and ... hence from 14 ... under 14'. When the researcher asked from her to show on the x-axis the solutions, she pointed out the numbers from 1 up to a little before 14 on the x-axis (figure 1). So, with this defect she means that 14 is not included in the solutions. It will now be observed that she is gradually succeeding in building and developing a cognitive scheme for inequality; and that intuitively she approaches the concept of *limit*, trying to interpret the genuine inequality $0 < x < 14$, via the graphic representation.

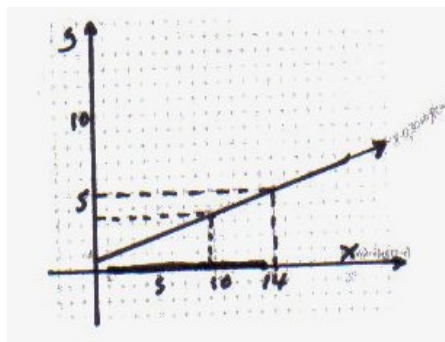

Figure 1

On the other hand Helen, an average performer, answered the question using the graph without difficulty. She overcomes an initial difficulty in order to understand the meaning of the word *change* and she begins to conceive a main difference between inequality and equation; that there are, more than one, solutions for the inequality:

Helen: ... if we gave 5€ we would go 14 kilometres (she did it using the graphic representation, as figure 2) ... he gave us exchange ... if we gave him 4.5€ we would do 13.5 kilometres... there are **many** solutions.

Contrary to Andrea, the fact that the cost of way was not precisely 5€, did not prevent Helen to bring, from 5 on y-axis, the suitable line in order to determine the corresponding value of x. Also, with her phrase *there are many solutions* show that she comprehends a basic conceptual difference between equation and inequality, and she starts to build a bridge between these two concepts, as it appears in the following extract:

Helen: we can pay various cost of money... with bigger the 5€ that corresponds to 14 kilometres...we can pay and half € and 2€... we can do also 13 and 12 and 10 and 11 kilometres... 14 cannot, that is to say the kilometres are **less** than 14.

An inequality is equivalent with 'many' equations

When Helen was encouraged by the interviewer to answer with an alternative way, she developed a very interesting approach to inequality, based on the notion of equation, namely via a *collection of equations*, whose solutions as a totality is equivalent to the inequality solution. Specifically she reported:

Helen: ...we find it with examples... or with the formula [she shows $y=0.3x+0.8$]... 5€ gives 14 kilometres [it had been found graphically]... $0.3x+0.8$... 14 kilometres ... we can do the same also with 4€ and 3€ and ... **equation**... there are many solutions.

She comprehends that the taxi fare is a number less than 5 and in order to find each route corresponding to such a fare she should solve the corresponding equation. Thus in order to find the routes for 4€ or 3€, she has to solve the equations $x \cdot 0.30 + 0.80 = 4$ and $x \cdot 0.30 + 0.80 = 3$, respectively, and in general for each fare less than 5, in order to find the route, the same procedure is to be used. According to Helen's thought all the solutions of these equations are possible answers to the question and hence possible answers to the inequality $x \cdot 0.30 + 0.80 < 5$. So the inequality represents the collection of all these equations. This idea, closely related to her initial conclusion that '*there are many solutions*', is an important action of understanding inequality, in that it locates a basic difference between inequality and equation, and so creates a 'bridge' between the two concepts, extending the equation concept. Speaking mathematically, Helen's idea is an intuition approach of the inequality solution set, that is: $\{x \in \mathbb{R} / 0.3x + 0.8 < 5\} = \{x \in \mathbb{R} / 0.3x + 0.8 = a, a < 5\}$.

The **values table mode** substantially constitutes a numerical, informal method, with trials for various values of x until $y=5$ come out, as developed for example from Helen:

Helen: 5 minus y , I want to see how many possibilities are there for the change he has taken ... there are a lot of solutions ... I will find them with a values table ... I will consider examples [Then she completed the values table with various values, until 6 € appeared and concluded] as it appears here, when he pays 5 euros he does 14 kilometres... well, we knew it before... however he takes back some change that is to say he pays less than 5... then he will do less than 14 kilometres ... as we see for example for 4.7 euros we do 13 km, more than 5 euros more than 14 kilometres

We believe that the values table strategy constitutes a fine and understandable first approach to the inequality, before its formal teaching.

Difficulties in constructing the inequality $ax+b < c$

Let us see the **obstacles** that students faced in order to give an **algebraic solution** to the problem. Two students (Sia and Sotiris under average performers) had difficulties to construct the inequality. For example:

Sia: '*y equals ... ok y is equal less ... can I say y equals less than 5 and to continue... because euros are less than 5... $y < 5$* '.

Sia could not make the transition from the inequality $y < 5$ to the equivalent inequality $0.80 + 0.30x < 5$ and thereby find the x values. Similarly, **Sotiris** had many difficulties in constructing the inequality. Although he realized that the cost paid is less

than 5 euros and reported the word *inequality*, understanding intuitively that the situation was not an equality relation, he presents an obvious disability to mathematize the situation formulating the inequality $5-y>0$, or the equivalents $5>y$ or $5>0.3x+0.8$. These two students' symbolizations are interesting, however the transition to inequality was an important problem and they were able to represent correctly only a part of the situation. It is possible that the formula $y=0.80+0.30x$ constituted an obstacle for them, because they could not identify the representation of the cost y with the expression $0.80+0.30x$. Only with the important and decisive interventions of researcher, these students '*achieved*' to construct the inequality. Without these essential interventions it was impossible that they could '*mathematize*' the problem constructing the inequality. The difficulty of the inequality construction was clearly formulated:

Sia: '*the equation and the inequality ok, I can solve them ... I can not easily construct them*'.

Olivia, an average performer, faced a different kind of difficulty for the inequality construction. The context of the problem helps her to distinguish that the situation is not exactly equation, but it requires a critical step, one more action of understanding in order to abandon the framework of equation and to realise the inequality:

Olivia: *we will do that as before ... $5=x \cdot 0.3+0.8$ based on the formula $y=x \cdot 0.3+0.8$ with $y=5€$... ok, he did not pay precisely 5€, almost 5€.*

With the word *almost*, she appears to comprehend the difference between the two situations. But the translation in mathematical code requires one more step, a push. The critical push for this passage is given by the researcher:

Interviewer: *more or less?* Olivia: *less... that is to say we should not use equality... it should be $5>x \cdot 0.3+0.80$.*

The intervention of the researcher ('*more or less*') was essential in her attempt to mathematize the situation and to construct the inequality. Firstly, the word *almost* and then the more concretely *less* make the difference between the equation (=) and the inequality (>). So, Olivia realise the transition from equation to inequality.

Difficulties in solving the inequality $ax+b<c$

In this point we should identify the obstacles that students faced in order to solve the inequality. The students solved algebraically the inequality using the same procedures as in the algebraic solution of the equation. Olivia and Sotiris reported it clearly from the beginning: '*the solution of the inequality will be as in the equation*'. This powerful identification, in solving equation and inequality, gives the impression to the students that the only difference is on the sign. That **misunderstanding** leads to faults, because algebraic transformations are performed without taking into consideration the constraints deriving from the fact that the $>$ sign does not behave like the $=$ sign (Tsamir et al., 1998). For example, **Sotiris**, solving the inequality $0.3 \cdot x+0.8<5$, wrote the equivalent $0.3x<4.2$ and continued dividing by 0.3 both sides. He did not appear sure about the inequality sign and lastly he concluded that:

S: *'I have to change the symbol ... it always changes in the end'* [and he wrote $0.3x/0.3 > 4.2/0.3$].

Similarly, **Helen** solving the inequality $5 > 0.8 + 0.3x$, wrote the equivalent $-0.3x > -4.2$. She divided with -0.3 both sides without changing the sign $>$ and found as solution $x > 14$. Observing this answer with her answer from the graph strategy, she understood that something wasn't going right, so she changed the sign $>$ with $<$ and justified it: *'it changes because it is negative'*. Here appears that the combined use of the different solution ways can use as a metacognitive process, and also, one representation can cancel out the disadvantage of another and prove to be an effective tool (Kaput, 1992). Although her explanation seems adequate, in another interview, solving the inequality $-1x < -4$, she acted without deeper understanding:

Helen: *I don't remember... I believe that it changes because in the right side there is a negative'*.

Also, when **Olivia** was solving the inequality $5 > 0.3x + 0.8$, and wrote the equivalent $4.2 > 0.3x$ she divided with 0.3 writing $x = 14$ (the erased equation, 2nd line in figure 3). The dialogue with the interviewer is characteristic:

Interviewer: *why the sign $>$ changed and became $=$?*

Olivia: [she changes her solution $x = 14$ and write $x \geq 14$].

Interviewer: *x was in the right side, why did you put it in the other side?*

Olivia: *aaa ...yes* [she erases the previous $x \geq 14$ and writes $14 \geq x$].

Interviewer: *why did you put the equal sign here? ... Could we have equality here?*

Olivia: *... if he gave 5 euros he would do 14 ... he takes change ... no it can't* [and she erases the sign $=$ and write $14 > x$].

She handled the unequal sign almost like the sign of the equation. This misunderstanding allows her to consider equivalent the inequalities $14 > x$ and $x > 14$, as it happens for the equations $x = 14$ and $14 = x$. The context of the problem helped him to check her solution and to correct the sign in $14 \geq x$ writing $14 > x$.

How to read the inequality $x < 14$?

Three students read the inequality $x < 14$ as follows: *'x equal less than 14'*. One possible interpretation is that these students are still thinking in terms of equation and make a corresponding mental transfer to inequality considering that the solution is 14. Another possible interpretation is that *'equal'* is used with the meaning of *'is'*, that is to say x *is* (a number) *less* than 14. In favor of the second interpretation is our observation that many students when they wish to represent by symbols the element requested in solving a problem, such as *'the number of the days'*, write *'x = days'* instead of the typical correct expression *'x is the number of days'*. The interpretation intended requires further investigation.

An obstacle in handling zero

Sotiris solving inequality transports all the terms to the right side and he observes that does not remain anything on the left side and concludes:

S: *we cannot continue because here there isn't anymore inequality.*

Sotiris, after moving the sole term from the left side to the other side, was unable to continue the solving process, because he considered that on the left side nothing remains and it was now an inequality that did not have one side. As such situation did not conform to his *concept image* (Vinner & Tall, 1981) for equation / inequality, he decided, finding himself in an impasse, that *I can not continue the process*. In this behaviour we detect an obstacle in handling symbols, specifically *student's weakness in handling or accepting zero as a number*⁷.

Approaching the inequality $ax+b < cx$ in a problem solving context

The graphs as problem solving strategy

Via the **parking problem** we can investigate the way that students approach the inequality of the form $ax+b < cx$ using multiple representations. From the beginning, *all* the students of the study use the graphs (visual representations) in order to answer the question. Firstly, they interpret them intuitively:

Helen: *both are economic, proportionally with the hours*

Step by step they concluded correctly which parking is *better proportionally with the hours*. Their explanations are based (a) on the spatial place of two lines (*this one is over the other*), or (b) finding the corresponding costs for concrete number of hours; taking values on x-axe less and great 4 (4 is the x-coordinate of the common point of lines) and then comparing the values of functions bringing vertical lines to axes x until they meet the graphs (figure 2). Students intuitively conceive the *rate of change* of functions observing the lines:

Panagiotis: *it goes up faster from this or*

Sotiris: *it begins from tally but as hours go up they are not a lot of money*

Then, interpreting them based on the situation context. All the students could use the graph as an important strategy of solving the inequality $ax+b < cx$ problem.

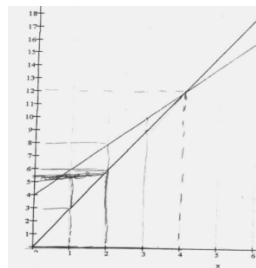

Figure 2. The values tables as problem solving strategy

Three students used the **values tables** of function to answer the question. They comprehend that the initial tables have few pairs of variable values and they should be supplemented (a) with as much as possible more pairs and (b) to give same values to independent variable in two tables. From the previous question (equation) they have found the common pair (answer to equation $2x+4=3x$) and now they supplement with other pairs until they can conclude when each parking is cheaper, as for example:

Helen: *we see that for 4 hours we pay the same... less than 4 the 2nd parking is more economic, for more than 4 is the 1st*

The inequality as problem solving strategy

The students tried to answer the question algebraically, only after interviewer prompt:

Interviewer: *can you answer the question in another way ... using symbols for example?*

Then they attempted to use the functions formulas in order to construct a model of the situation, in this case to write an **inequality**. The variable y in the two formulas appeared to create an obstacle for some students, for example:

Olivia: *I can't do something as before [mean equation] ... I have two unknowns*

The interventions of researcher and the problem context facilitated them to realize the situation, as for example it appears in the following extract:

Andrea: *for the first parking ... to be more interest this amount $[2x+4]$ should be smaller than it $[3x]$, and then to write the inequality $2x+4<3x$*

For low performance students there are more important obstacles in algebraic resolution of inequality. For example their solving processes are exactly similar to corresponding equations with result, among others, the following misunderstandings: (a) to divide with an negative number without change the inequality sign; (b) to write $4>x$ as $x>4$, because they consider that these inequalities are equivalent as the equations $4=x$ and $x=4$. The last misunderstanding is a result of the difficulty to interpret the inequality $4>x$ based on the situation. Generally, in the solution of the inequality of the parking problem the students faced analogous problems and obstacles as they referred in the taxi problem.

Discussion

The situation context and the use of function representations helped students to develop multiple solution ways. The transition, from one to another way of resolution, constituted a support for the students in order to improve their thought developing control processes. In addition, situation context was proved decisive for meaning construction with regard to inequality concept and the corresponding symbolisms. A characteristic example is the inequality approach as a collection of infinity equations, something that recommends an important energy of comprehension. The functional approach gave them a tool to distinguish the two concepts in contrary to the traditional way that creates misunderstanding that equation and inequality are 'same', only the symbol changes.

The graphic representations as models of problems give a more clear view of the situations which has as a result the students to have a deeper comprehension of problem solving processes. Representations acted complementary. One representation could cancel the disadvantages of another (Kaput, 1992). This was decisive for controlling the problem solving processes; for example when the algebraic solution did not agree with the graphic solution student should seek out the ‘error’.

Also, the tables constitute a numerical, not formal, but however understandable approach from students. And we agree with Meyer (2001), who considers that it is preferable for student to use a less formal strategy with comprehension rather than a most formal without comprehension.

Symbolic representations and their handlings (algebraic inequalities) create a lot of obstacles in novice understanding. We consider that this approach must be the final level of approach of concept, contrary to that it happens with the traditional way of teaching the inequality. An obstacle with regard to the inequality comprehension is the uniqueness of solutions. For example linear equation $0.8+0.3x=3.5$ has the number 9 as solution, while in inequality $0.8+0.3x<5$ (in problem context) has the open interval $(0, 14)$, a concept very difficult even for older students.

Generally, we observed that this approach to beginning algebra, based on function and their multiple representations in a problem solving context, facilitated students: to develop a deeper understanding on basic concepts as variable, function, equation and inequality; to connect these concepts and to use function representations as strategies for solving problems of linear equations and inequalities. But, we consider that is required moreover research on students who have not any previous experience with algebra (equations, rational numbers, algebraic expressions) in order to realised her effect in novices, who imported in algebra via function representations for a long time period.

References

- Ainsworth, S., Bibby, P., Wood, D. (1998). Analysing the Coasts and Benefits of Multi-Representational Learning Environments. In *Learning with Multiple Representations*, edited by M. W. van Someren, P. Reimann, H. P. A. Boshizen and T. de Jong, pp. 120-34. Oxford, U. K.: Elsevier Science.
- Bednarz N., Kieran C., and Lee L. (eds), (1996). *Approaches to Algebra: Perspectives form Reserch and Teaching*, Dordrecht, Netherlands: Kluver Academic Press.
- Boero P., Bazzini L. (2004). Inequalities in Mathematical Education: The need for complementary perspectives, *Proc. of PME28*, Bergen, Norway, I, 137-139.
- Bardini, C., Pierce, R. & Stacey, K. (2004). Teaching linear functions in context with graphics calculators: students’ responses and the impact of the approach on their use of algebraic symbols. *International Journal of Science and Mathematics Education*, 2, 353-376

- Duval, R. (2002). The cognitive analysis of problems of comprehension in the learning of mathematics. *Mediterranean Journal for Research in Mathematics Education*, 1(2), 1-16.
- Farmaki, Klaoudatos & Verikios (2004). From functions to equations: introduction to algebraic thinking to 13 year-old students, *Proc. of PME28*, Bergen, Norway, IV, 393-400.
- Farmaki, Klaoudatos & Verikios. (2005). Introduction to Algebraic thinking: Connecting the Concepts of linear Function and linear equation. In *Scientia Paedagogica Experimentalis*, vol. XLII nr.2, pp.231-254.
- Freudenthal, H. (1991). *Mathematics as a New Educational Task*. Dordrecht, Netherlands: Kluwer Academic Publishers.
- Friedlander A., Tabach M. (2001). Promoting Multiple Representations in Algebra. In *The Roles of Representation in School Mathematics*, eds. Cuoco A., Curcio, F. R., Reston V.: NCTM.
- Kaput, J. (1992). Technology and mathematics education. In D. A. Grouws (Ed.), *Handbook of research on mathematics teaching and learning* (pp. 515-556). New York: Macmillan.
- Kieran, C. (1992). The learning and teaching of school algebra. In D. Grouws (Ed.), *Handbook of Research on Mathematics Teaching and Learning* (pp. 390-419). New York: McMillan & National Council of Teachers of Mathematics.
- Kieran C. (1996). The changing face of school algebra. In *8th international congress on mathematical education, selected lectures*, S.A.E.M. 'THALES', 271-286.
- Kieran C. (2004). The equation/inequality connection in constructing meaning for inequality situations, *Proc. of PME28*, Bergen, Norway, Vol. I, 143-147.
- Klein, F. (1945). *Elementary mathematics from an advanced standpoint: Arithmetic, algebra, analysis*. Translation of the 3rd edition in German. New York: Dover Publications. Kluwer academic publisher.
- Meyer, M. (2001). Representations in Rerealistic. In *The Roles of Representation in School Mathematics*, eds. Cuoco A., Curcio, F. R. Reston V.: NCTM.
- Monoyiou and Gagatsis, 2007. *A coordination of different representations in function problem solving*, preprint.
- National Council of Teachers of Mathematics (NCTM) (2000). *Principles and Standards in School Mathematics*. Reston, Virginia.
- Piaget, J., Grize, J.B., Szeminska, A., & Bang, V. (1968). *Epistemologie et psychologie de las fonction*. Paris: Presses Universitaires de France. (English version published in 1997 by D. Reidel publishing).
- Sackur, C. (2004). Problems related to the use of graphs in solving inequalities, *Proc. of PME28*, Bergen, Norway, I, 148-152.

- Schwartz & Yerushalmy (1993). Seizing the opportunity to make algebra mathematically and pedagogically interesting. T. Romberg, E. Fennema, T. Carpenter (eds) Integrating research on the graphical representation of functions. Lawrence Erlbaum Associates.
- Sokolowski C., 2000. The variable in linear inequality: college students' understandings. *22nd Annual Meeting of the International Group for the Psychology of Mathematics Education*, Tucson, Arizona October 7-10, 2000
- Stacey, Chick & Kendal, (Eds), (2004). *The Future of the Teaching and Learning of Algebra: the 12th ICMI Study*. Kluwer Academic Publishers.
- Tall, D. & Vinner, S. (1981). Concept Image and Concept Definition in Mathematics, with Particular Reference to Limits and Continuity. *Educational Studies in Mathematics 12*. pp. 151-169.
- Tsamir P., Almog N., Tirosh D. (1998). 'Students' solutions of inequalities', *Proc. of PME 22*, Stellenbosch, South Africa, VI, 129-136.
- Tsamir, P., Almog, N., 1999, "No answer" as a problematic response: The case of inequalities. *Proceedings of PME 23*, Haifa, Israel, Vol. I, 328.
- Thorpe, J. (1989). What should we teach and how should we teach it? In Wagner, S & Kieran, C (eds), *Research issues in learning and teaching of algebra (vol. 4)*. Lawrence Erlbaum Associates, NCTM. pp11-25.
- Verikios, P., Farmaki, V. (2006). *Introducing algebraic thinking to 13 year-old students: The case of the inequality*. *Proc. of PME 30*, Prague, Czech Republic, V, 321-328.

CHAPTER 5:

History and Philosophy of Mathematics



The anthyphairetic interpretation of Zeno’s fragments B2, B1 and B3

Stylianos Negrepontis* & Ioannis Salonikides**

*Department of Mathematics, University of Athens

**Department of Education, University of Cyprus

Abstract

*The interpretation of Zeno’s three fragments B2, B1 B3 has been traditionally considered as difficult and opaque. These fragments have been studied by distinguished scholars, especially Frankel and Vlastos, who are responsible for the dominant interpretation. However, existing interpretations present serious weaknesses, including (a) that they are in no position to explain exactly how Zeno’s arguments helped the basic philosophical thesis of his teacher Parmenides on the existence of intelligible beings, separate from the sensibles, (b) that they are in no position to interpret Simplicius’ extensive and significant scholia on Zeno’s fragments in his work *eis Phusika*, the only ancient work which presents verbatim a small part of the philosopher’s own work, (c) that they are forced to change the (logical) order in which these fragments-arguments are presented, (d) that they are forced to take refuge in the questionable and indeed erroneous hypothesis that Zeno himself makes rather gross logico-mathematical errors, and (e) that they are in no position to connect Zeno’s thought to Plato’s dialectics in the *Parmenides*, despite Frankel’s fundamental intuition that the two are strongly related. In this paper we present a novel interpretation of Zeno’s fragments, based upon the anthyphairetic interpretation (of the Pythagorean philosophy and) of Plato’s dialectics in the *Parmenides*, given earlier by S. Negrepontis, and on the strong connection between Plato’s dialectics in the *Parmenides* and Zeno’s fragments, that has none of the aforementioned weaknesses. In this paper we concentrate on the presentation of our interpretation, in a preliminary and self-contained form and so existing interpretations are not systematically analyzed.*

1. The order of Zeno’s arguments

Simplicius, in his work *eis Phusika*, mentions and comments on three fragments by Zeno concerning plurality-division, which are symbolised (according to Diels-Kranz (1964)) with B2 for fragment 139.11-15, B3 for fragment 140.29-33, and B1 for fragment 141.2-8. According to the analysis which follows, B1 organically includes B1.0=139.18-19 (=denoted S1 by Vlastos) [References to Simplicius’ *eis Phusika* will be made using page and line numbers]. It is important to define the correct order in which Zeno develops those arguments, which Simplicius mentions, as this order partly

reveals the overall logic of these arguments (described in the next section 2). Fortunately, Simplicius offers enough information from which it is possible to determine with accuracy the order of Zeno's arguments B1, B2 and B3.

The infinite according to magnitude, i.e. the infinite in argument B1, is, according to Simplicius, 'first' ('proteron') established by the same process (140,34-35), that the infinite multitude, i.e the infinite in argument B3, is established. But the infinite in argument B3 follows from dichotomy (140,34), hence the infinite in argument B1, following by the same process (140,35), follows from dichotomy. We conclude that not only the argument of fragment B3, as Simplicius explicitly mentioned in 140,34, but also the argument of fragment B1, is a dichotomy argument. Consequently B1 precedes B3, and both are arguments of dichotomy.

In order to explain (the explanatory nature of the sentence being deduced from the presence of the term 'gar') the fact that B1 precedes B3, Simplicius adds "For, having first shown ("prodeixas gar") (141,1) B2, he "induces" ('epagei') B1. Here the word "induces" has the sense of "proceeds directly with", so that after the argument of B2, he transfers directly to argument B1, and it is for that for that reason that B3 follows B1. Consequently B2 precedes B1.

Furthermore B1 consists of two parts: (a) each one ('hekaston') of the many has no magnitude and (b) each one ('hekaston') of the many has magnitude, indeed there are infinite in magnitude. Simplicius informs us that Zeno proves the second one (b), having first proven ('prodeixas') (139,18-19) the first (a). The conclusion to B1 is formulated in the same order ("small so...great so as"), as opposed to the order in the preliminary description "are both large and small". In B3, which also consists of two parts, the two parts have correspondingly the same order: "the same things are both finite and infinite" (140,28-29, and 140,31)).

Thus the sequence in which Zeno develops his arguments is now clearly defined: first fragment B2, then the two dichotomy arguments in the fragments B1 and B3, initially fragment B1 (the first part of which, B1.0=S1=139,18-19 is the argument of "no magnitude", not explicitly stated as such, the second that of the infinite), and finally fragment B3 (first with the argument of the Finite ('peras'), then with the argument of the Infinite).

2. The logical structure of Zeno's arguments

The argument of fragment B2 is a direct argument, while the arguments (from dichotomy) of B1, B3 are arguments of *reductio ad absurdum*. The origin of this type of arguments must be credited to the Pythagoreans and is related to the proof of the incommensurability, according to the arguments given by S. Negrepontis (preprint a).

Such an argument is based in the logical acceptance that for any statement (A), the double logical denial, denoted $\sim(\sim(A))$, of (A), is logically equivalent to statement (A), and thus in order to prove the validity of (A) it is enough to prove that statement $\sim(A)$ false. Thus, in such an argument we presume the logical negation, denoted $\sim(A)$, of statement (A) which we want to prove, and with this assumption, i.e. $\sim(A)$, we attempt to deduce something false, impossible and absurd.

In the case of Zeno, "if $\sim(A)$ " is the statement "if there are many". The question is what is the meaning of this statement ("if there are many") and what exactly statement (A) is, which Zeno wanted to establish. In this direction there is some evidence which could help us. First, Simplicius explains with clarity and invoking Eudemus, that "the many" are "the sensibles" (*eis Phusika* 97, 13-15 and 138,29-139,5). Second, Zeno was a pupil of Parmenides. Parmenides believed that there were two separate ways, the way of opinion ("doxa"), characterized by continuous unceasing phenomenal but deceptive change, and the way of truth, which is characterized by unity, stability and lack of change. It is clear that the sensibles are identical to the way of opinion (30.14-16). With such dogma, Parmenides appears to be the first thinker in the history of humanity, who expressed the existence of beings beyond the sensibles, separated from the sensibles, i.e. expressed the existence of "intelligible", as Plato named them later, beings. Simplicius (*eis Phusika* 88,24-27), expresses with clarity the difference between the sensible and the intelligible: "the sensible fragmentation..." ('o aisthetos diasposmos') does not accept the "intelligible union" ('noeten henosin'), and it is not possible to observe "in the sensibles" ('en tois aisthetois'), "the complete unification of the one", which comprises the characteristic "in the intelligible", that "the unified existence"..."embraces"..."multiple division".

Furthermore, according to Plato, in the *Parmenides* 128c5-d6, and to Simplicius, *eis Phusika* 134.2-4, Parmenides' contemporaries ridiculed his philosophical views about the existence of intelligible beings. Zeno tried to construct arguments which ridiculed the views of Parmenides opponents, those that is who did not believe in the existence of beings separate from the sensibles.

Hence we can accept with confidence that statement (A) which Zeno tried to prove was "there are intelligible beings separate from the sensibles". Then the statement $\sim(A)$, the logical negation of (A), must state that "there are no beings separate from the sensibles", i.e. in Zeno's words, "there are no beings separate from the many". But Zeno's hypothesis $\sim(A)$ is "ta polla hestin", the many are. We conclude then, that the Zenonian hypothesis $\sim(A)$ is the statement "the many, the sensibles, are identical to the true intelligible beings".

3. The basic methodology for the interpretation of Zeno's fragments

At this point we might ask in which way, from this statement $\sim(A)$, sensible=intelligible, Zeno could reach something illogical and ridiculous, and thus succeed in defeating Parmenides' opponents. Apparently he must have possessed a model for the intelligible beings, which are not accessible to us, to compare with the sensible familiar to us. How then could we obtain the knowledge of this model for

intelligible beings, which Zeno had? Based on the fact that from Zeno's beliefs, the only authentic word for word arguments preserved are the three short fragments B2, B1, B3, it is clear that we can have a chance of success only if we attempt to escape the narrow confines of these fragments and seek relations between these and the arguments of other subsequent thinkers, who have a philosophical affinity to Zeno. We find this affinity in Plato, especially in his dialogue *Parmenides*: indeed, as we shall see in subsequent sections, careful study reveals remarkable similarities between Zeno's fragments and passages from Plato's *Parmenides*.

The use of the *Parmenides* for the interpretation of Zeno's fragments was conceived by Fraenkel (1975), p.124, who, however, failed to follow through his correct intuition. This is so because the exploitation of the *Parmenides* as the base for the interpretation of Zeno's fragments must be preceded by the correct and true interpretation of Plato's dialogue, and generally of Plato's dialectics; Fraenkel and probably subsequent researchers might well be in a position to locate the remarkable linguistic similarities between Zeno's fragments and the *Parmenides* (although we have no explicit evidence of that), but they were in no position to use these similarities, as long as the *Parmenides* itself remained inaccessible to an essential interpretation, based on the philosophical analogue of the geometrical method of periodical anthyphairesis and its resulting self-similarity.

The bare outline of such an interpretation of the *Parmenides* is as follows: in the *Parmenides*, after an important introduction (126a-137c), where the basic philosophical questions related with the nature of intelligible beings and their relation with the sensibles are posed (including the separation of the intelligibles from the sensibles and the participation of the sensibles in the intelligibles), Plato first, in the "first hypothesis" (137c-142a), deals with the absolute One, the One itself, which has a negative character, and then, in the "second hypothesis" (142b-157b), with the One Being, the One which is not the One itself, but that One which characterizes the intelligible beings.

The interpretation of Division and Collection, the basic method of Plato's dialectics in his trilogy *Theaetetus-Sophistes-Politicus* and in the dialogues the *Phaedrus* and the *Philebus*, as the philosophical analogue of the geometrical method of periodical anthyphairesis, has been developed by S. Negreontis in a sequence of articles (1999), (2000), (2005), (preprints b, c), who proves in (preprint b) that the intelligible Platonic Being, described in the second hypothesis of the *Parmenides* (142b-157b), is the philosophical version of a pair of opposing species ('indefinite dyad') with the power of periodical anthyphairesis and resulting self-similar Oneness; the plethora of the seemingly contradictory claims in the second hypothesis turn into fully consistent and logically true statements, under this interpretation.

We will see that fragment B2 is closely related to the first hypothesis of the *Parmenides*, and that Fragments B1 and B3 to the second, and thus to the philosophic analogue of periodic anthyphairesis and resulting self-similar Oneness.

4. The interpretation of Fragment B2

4.1. *The translation of Fragment B2 (139,9-15)*

“Now in this [work] he proves that what has neither magnitude, nor mass, nor bulk, would not even exist”. “For”, he says, “if it were attached to something else that exists, it would not make it larger; for if it is of no magnitude but is attached, that thing cannot increase at all in magnitude. And in this way what is attached will thereby be nothing. And if, when it is detached, the other thing is no smaller, and, when it is attached again, it will not grow, it is clear that what is attached is nothing, and likewise what is detached. [Barnes (1986), p. 238]

4.2. *The interpretation of Fragment B2*

Fragment B2 is an absolute statement with a true conclusion, and not one under the hypothesis “if there are many”, aiming at a *reductio ad absurdum*. The statement of B2 is simple: if an entity is an intelligible being, then this entity cannot be absolutely partless, on the contrary it must have parts.

Zeno's fragment B2 fully agrees with Plato's belief about the intelligible being in the first hypothesis of the *Parmenides* (137c-142a) and in passage 244b-245d in the *Sophistes*. We ascertain that the One of the first hypothesis in the *Parmenides* completely lacks parts (137c-d), and hence is identical with the One itself in the significant passage in the *Sophistes* (245a1-c5), which also has no parts. According to the *Parmenides* 141d-142a the One of the first hypothesis is rejected as intelligible being, and this agrees with the *Sophistes* 245a-c, where the absolutely partless One itself is not the intelligible Being, but on the contrary it is a subjected, passive one (‘*hen peponthos*’), a One subjected to division, passively accepting division, and thus with parts.

In addition Simplicius makes clear that the model for the absolutely partless One itself, described by Zeno's Fragment B2, is the “*stigma*”, the geometrical point (81,36-37; 82,8-9; 97,15; 99,11; 139,1). It must be noted that a similar rejection of ‘*stigma*’ (in favour of the indivisible line) by Plato is reported in Aristotle's *Metaphysika* (992a19-24).

This correlation, of Zenonian Fragment B2 with the first hypothesis in the Platonic *Parmenides*, reveals the probable reasons for which Zeno was obliged to move away from the absolutely partless geometrical point. In the introduction of the *Parmenides*, specifically in the passage 133a11-135c4, the necessity that the intelligibles be participated by the sensibles is dramatically set forth. In the main part of the *Parmenides*, the first hypothesis about the One corresponds to the non communicative absolute partless One, as clearly stated in the final paragraph 141d7-142a8 of the first hypothesis, with the sentences: “nor is there any knowledge or perception or *doxa* of it” and “nor will it be an object of opinion or knowledge, nor does anything among things which are perceive it”.

This appears to be the major difficulty of the Parmenidean intelligible One, the total separation from the sensible, a separation which excessively reduces the world in which we live, and severs it off from something superior. Such a permanent and definite abasement of human nature could not possibly meet with acceptance in the profoundly anthropocentric Greek civilization.

It is then maintained that the arguments developed in the *Parmenides* by Plato, for the necessity of communication, reflect Zeno's thought to reject the non communicating One and to seek another intelligible One, which communicates with the sensibles and hence has magnitude and parts; and that Zeno with his argument in B2 is trying to move away from a non communicating Parmenidean One and to seek this suitable One, which has the power of communication with the sensibles.

5. The interpretation of Fragment B1

5.1. The translation of passage B1.0=S1 (139,16-19) and of fragment B1 (140,34-141,8)

Simplicius' passage B1.0=S1 (139,16-19) is rendered as follows:

'And Zeno says this not in order to reject the One, but to show that each of the many things has a magnitude- and an unlimited one at that (for there is always something in front of what is taken, because of the unlimited division).

And he proves this having first proved that each of the many has no magnitude from the fact that each is the same as itself and one.' [Barnes (1986), pp. 238-239]

Zeno's fragment B1 (140,34-141,8) runs as follows:

'The infinity of magnitude he showed previously by the same process of reasoning. For, having first shown that "if what is had not magnitude, it would not exist at all", he proceeds:' [Lee (1936), p. 20, fr10]

"So if [many] exist, each [existent] must have some size and bulk and some [part of each] must lie beyond ('apechein') another [part of the same existent]. And the same reasoning ['logos'] holds of the projecting [part]: for this too will have some size and some [part] of it will project. Now to say this once is as good as saying it forever. For no such [part—that is, no part resulting from this continuing subdivision] will be the last nor will one [part] ever exist not [similarly] related to [that is, projecting from] another." (Fr. 1, [Zeno B1] first part) [Vlastos (1967), p. 243]

"Thus, if there are many, they must be both small and great: on one hand, so small as to have no size; on the other, so large as to be infinite" (Fr. 1, concluding part). [Vlastos (1967), p. 244]

5.2. Zeno's transition from the position of rejecting B2 to the position of adopting B1

With the argument of fragment B2, Zeno rejected the absolutely partless One, whose model is the geometrical "stigma", as the proper One for the intelligible Being. As discussed above in 4.2, the reason for the rejection must be sought in Zeno's ascertainment that the sensibles are many and divisible, hence they need some kind of unifying power; but the partless One (and the geometrical point), as absolutely partless, is not suitable to unify the sensibles. The quest for the proper unifying power of the intelligible and real Being is undertaken under the all-important condition that this Being is in some kind of communication with the sensibles and that there is no complete lack of communication and participation.

At this crucial point, Eudemos' testimony, which is reported to us repeatedly by Simplicius (97,9-19 and 138,30-139,3), is particularly enlightening about Zeno's thought. According to this testimony, Zeno was perplexed, as to the proper unifying power, which could describe the Being. ("if anyone would explain to him what the one is, he would be able to speak about existent things") [Lee (1936), p.15].

We must realize that Zeno, after and the rejection of the One itself as being with his argument B2, still remains faithful to the basic Parmenidean thesis, that the intelligible is some kind of One; but the condition of communication with the sensibles, which Zeno seems to adopt, leads to the search for some kind of One that has parts. But how could an entity with parts, ever possibly be described as One? Such an entity would then be One and many, something which Aristotle rejects as contradictory in *Phusika* 185b25-186a3 ("could not be at the same time one and many", it is not possible for the same to be both one and many"). It is for this reason, as Simplicius informs us in 138,3-6, that the Aristotelian commentator Alexander believes that Zeno refuted the One as the proper description of the intelligible Being. But Simplicius assures us that this is not the case (141,8-10): Zeno with his argument B2 has absolutely no intention to refute the One as intelligible Being. This results, according to Simplicius, from the fact that Zeno in the next dichotomy argument B1, from the hypothesis that "the many are", i.e. "the many are intelligible Beings", proves that each one of the many

[a] "has no magnitude ('ouden echei megethos'), because it is "self similar " ('heauto tauton') and One, and

[b] "it has magnitude" ('echei megethos').

According to the argument, which we developed in section 2 above, it follows that every intelligible Being, is according to Zeno

[a] "heauto tauton" and One, hence "ouden echei megethos", and

[b] "echei megethos".

As we will argue below, it follows from [a] that the Zenonian intelligible Being is One, in the sense of self similarity (5.3 and 5.4), and from [b] that the Zenonian intelligible Being is many (5.5 and 5.6). Hence it follows, from the dichotomy argument B1, that the Zenonian Being is not ONLY One, but BOTH One and Many. This property, which, as we have seen, is rejected by Aristotle as contradictory, is however valid for the Platonic intelligible One of the second hypothesis in *Parmenides*, as declared explicitly

in 145a2. Simplicius informs us that Zeno was called “speaking both ways” or “double-tongued” (‘amphoteroglossos’), exactly because he argued for an intelligible Being which was One and many (139,4 and 1011,13). Simplicius, in 139,19-23, reinforces this thesis by referring to Themistius’ description of the oneness of the Zenonian Being as being both infinitely divisible (since ‘contiguous’) and indivisible.

5.3. The interpretation of the expression “tauton heauto” (139,18-19)

In order to be able to reach the correct interpretation of the Zenonian “tauton heauto” (in terms of self-similarity, we examine the interpretation of this expression in Plato generally, and especially in the Second hypothesis of the *Parmenides*. At first sight, the statement ‘x is tauton heauto’ could be considered a trivial tautological assertion of the type ‘x=x’. That this is not the case can be realized by the fact that the proof provided that the One of the second hypothesis in *Parmenides* satisfies this property (in 146b2-c4), is a non trivial one, and also by the fact that the One of the first hypothesis DOES NOT satisfy this property (139b4-e6).

From passages 78c1-d9, 80a10-b7 in the *Phaedo*, it results that “heauto homoiotaton” is described as incomposite (‘asuntheton’), indissoluble (‘adialuton’), self similar (‘monoeides’) and according to the same analogously (‘kata tauta hosautos’). These descriptions are consistent with the anthyphairtic interpretation of the *Parmenides*’ passage 146b2-c4, which is given in Negreptis (preprint b), according to which the One of the second hypothesis is “tauton heauto”, in the sense that the One is preserved unchanged, while moving from one stage to the next, and, since this process is anthyphairtic, as it moves from one stage of anthyphairesis to the next, and this preservation and self similarity is achieved because of the periodic nature of the anthyphairesis.

Vlastos (1971), in his attempt to reconstruct the proof that every Zenonian intelligible Being is “heauto tauton”, refers to fragment B9 of Melissus. But (a) the intelligible Being in Melissus’ B9 is absolutely partless, hence is identical to the One of the first hypothesis of *Parmenides*, which, as we have seen in paragraph 4, has been rejected by Zeno’s B2 as an intelligible Being and (b) the intelligible Being in B1.0=S1 (=139,18-19) and generally in Zeno’s B1 fragment, is identical to the One of the second hypothesis of *Parmenides*. So, Vlastos’ reconstruction could be refuted, because it erroneously identifies the One of the first hypothesis with the One of the second hypothesis.

Solmsen (1971), differentiating his interpretation from that of Fraenkel-Vlastos, considers that B1.0=S1 (=139,18-19) is employed, in combination with B2, for the refutation of the One and the support of the many, as follows: (b) from B1.0, if x is “heauto tauton” and one, then x is partless, and (a) from B2, if x is partless then x is not an intelligible Being. Hence, according to Solmsen’s interpretation, the One is not an intelligible Being. Solmsen’s error is similar to Vlastos’: (b) x in B1.0 and generally in B1, is the One of the second hypothesis of *Parmenides* (it is both partless and infinite in

magnitude), while (a) x in B2, is the One of the first hypothesis of *Parmenides* (it is ONLY without magnitude, as absolutely partless).

5.4. The interpretation of the sentence “homoion de touto apax te eipein kai aei legein”

The basic method of Division and Collection, with which the human soul acquires the knowledge of Platonic Beings and Ideas, is presented in the trilogy *Theaetetus-Sophistes-Politicus*, and also in *Phaedrus* and in *Philebus*. An equivalent description of Division and Collection is the “Name and Logos”, where the Name corresponds to Division and the Logos to Collection. The anthyphairctic interpretation of Division and Collection has been described by S. Negrepointis (2000), (preprint c). In the second hypothesis in *Parmenides* 147c1-148d4, there is a significant description of the process Onoma and Logos, in a way closely related to Zeno's fragment B1. We especially examine passage *Parmenides* 147d3-e6; according to it, the “logos”, which is set in the same “tauton” name (particularly in the name other “heteron”), once or many times, is always “tautos”. The anthyphairctic interpretation of this passage of *Parmenides*, according to Negrepointis (manuscript b), is that one “pros ti” being, one “heteron pros heteron”, i.e. one logos of one part- anthyphairctic remainder to the successive part-anthyphairctic remainder, which were born in the division process (Diairesis) of one intelligible Being, is “tauton”, according to the periodic and hence self-similar procedure of Collection to every one “pros ti” being of the same intelligible Being.

We observe that the sentence ‘homoion the touto apax te eipein kai aei legein’ (141,5) in Zeno's fragment B1 presents an irresistible similarity to the passage of *Parmenides* which we examined. It is logical, that from this anthyphairctic interpretation of *Parmenides* 147d3-e6, we can infer the corresponding interpretation of Zeno's B1 fragment. It follows that the word “touto” refers to “heteron” of line 141,3, and that the Zenonian “heteron” has the Platonic meaning of “heteron”, and furthermore that the meaning of the Zenonian sentence under examination is identical to the meaning of the similar Platonic, which has already been interpreted with anthyphairesis.

5.5. In the Zenonian intelligible being, an infinite number of parts is produced

Let us see first how Zeno proves that each of the many is “infinite according to magnitude”.

The part of Argument B1, which is quoted verbatim, is analyzed in the following phrases:

[0] “if (many) exists” (‘ei polla hestin’),

[a] then “each one has magnitude and bulk” (‘hekaston megethos ti echein kai pachos’),

[b] “must lie beyond (‘apechein’) another [part of the same existent]” (‘apechein autou to heteron apo tou heterou’).

[c] “And the same reasoning holds of the projecting [part]” (‘kai peri tou prouchontos o autos logos’);

[d] “for this too will have some size and some [part] of it will protrude” (‘kai gar ekeino exei megethos kai proxei autou ti’)

[e] “Now to say this once is as good as saying it forever.” (‘homoion the touto apax te eipein kai aei legein’).

[f] “For no such [part—that is, no part resulting from this continuing subdivision] will be the last nor will one [part] ever exist not [similarly] related to [that is, projecting from] another.” (‘ouden gar autou toiouton eschaton hestai oute heteron pros heteron ouk hestai’).

As Fraenkel correctly argued, the word “autou” in sentences [b], [d], [f] has the meaning of possession of part (“partitive-possessive”). Thus in [b] it is declared that the “hekaston” of [a] has two parts, both of which are referred to as “heteron” and “hetera”. According to [c], one of these two “hetera” parts is the “proechon” (protruding), i.e. the bigger in relation to the “heteron” part. If a_1 is the initial “hekaston” part, a_2 the protruding part of a_1 , and a_3 the “heteron” non-protruding part of a_1 , then the relation described in [a] and [b] between these parts is precisely the following:

$$a_1 = a_2 + a_3 \text{ with } a_2 > a_3.$$

We recognize that, of course, this is an anthypairetic relation. We note here that Fraenkel (1975), p.118, had initially proposed a clumsy procedure, according to which “the one (part) of it (of the single thing) must be distant from the other”, “the contrasted two parts of it are likely to be opposite sides or surfaces”, which Vlastos (1971) seriously improved on Fraenkel and obtained the above relation. Vlastos however does not realize that the relation is an anthypairetic one. The next part of Vlastos’ interpretation is divisional ad infinitum with the production of infinite number of parts, but it is not anthypairetic, like the one we propose. Before we proceed with our interpretation, we must note a problem which previous scholars, and especially Vlastos, do not appear to have dealt with. How come the divisional relation which we have obtained ($a_1 = a_2 + a_3$ with $a_2 > a_3$) (independently of whether it be anthypairetic or not), and which constantly reproduces itself, while is clearly a division in two UNEQUAL sections, is nevertheless called a dichotomy?

Sentences [c] and [d] signify that exactly the same holds for the protruding part a_2 , as for the initial “hekaston” a_1 , and that the protruding part a_2 is composed also of two parts, one of which is again the protruding, i.e. the bigger one, in relation to the other.

At this point we note that a_3 , the smallest of the two parts of the initial “hekaston”, is equal to a fraction of the protruding part a_2 , and thus we can consider a_3 as part of a_2 . According to [f], there is no final “heteron”, on the contrary every “heteron” will be “heteron” to another following and smaller “heteron”, and thus [f] indicates clearly that the sequence of “heteron” is linear, totally ordered. Hence since a_2 is “heteron” and a_3 is also “heteron” and a fraction of the protruding a_2 , we may reasonably conclude that the protruding part of a_2 is equal to a_3 , and is completed by another “heteron” a_4 , so that we have the second relation:

$$a_2 = a_3 + a_4, \text{ with } a_3 > a_4.$$

Of course, this second relation is the continuation of the anthyphairctic process. From sentences [c] and [e] (which we have already analyzed in 5.4, above), it is clear that the anthyphairesis continues in the same way ad infinitum:

$a_n = a_{n+1} + a_{n+2}$, with $a_{n+1} > a_{n+2}$ for any $n=1,2,3,\dots$

The divisional-anthyphairctic ad infinitum procedure, which is described in B1, is identical to the anthyphairctic process of the One of the second hypothesis in *Parmenides*, especially in passage 142b5-143a3. Indeed S. Negrepointis (preprint b) fully analyzes this passage, shortly described as follows: The One Being of the second hypothesis, consists of the indefinite dyad, whose two initial parts, One and Being, are divisible ad infinitum, so that:

One=Being+One₁, with One₁< Being

Being=One₁+Being₁, with Being₁<One₁

...

One_k=Being_k+One_{k+1}, with One_{k+1}<Being_k

Being_k=One_{k+1}+Being_{k+1}, with Being_{k+1}<One_{k+1},

...

The close connection between the divisional process in Zenonian fragment B1 and the divisional process of the One in *Parmenides*' second hypothesis, is obvious; it is emphasized by the fact that the Platonic argument, which appears as the anthyphairesis of the indefinite dyad of parts One and Being, is described in the immediately succeeding passage *Parmenides* 143a4-b8, exactly like the Zenonian, by means of the term "heteron".

The anthyphairctic interpretation we have reached can be reinforced by the following association: "proechein" also appears in the description of Zeno's second paradox, the so called "Achilleus", by Aristotle in *Phusika* 239b14-29, where Zeno claims to prove that the slower should always protrude ('proechei') in relation to the faster. We could plausibly suppose that the rather unusual word "proechein", which appears in different forms three times in the passage, is Aristotle's loan from Zeno, and that Zeno uses it in the paradox "Achilleus" with the same meaning as in fragment B1. As Zeno's first paradox of dichotomy has an anthyphairctic interpretation, described in Negrepointis (preprint a), and the second is a slight variation of the first, it is reasonably expected that the second paradox has an anthyphairctic interpretation, similar to the first. Thus, fragment B1, related to "Achilleus", because of the presence in both of the word "proechein", could plausibly have an anthyphairctic interpretation as well.

5.6. The meaning of "infinity according to magnitude"

The conclusion of the (divisional) argument, which we analyzed in 5.4, in fragment B1, is summarized as follows: "if there are many...it is necessary for them...to be large, so as to be infinite" ('ei polla hestin...anagke auta...megala [einai], hoste apeira einai'). Simplicius, in 140,34, describes this conclusion as: "ei polla hestin" (if there are many), then "hekaston" (each one) of the many is infinite "according to magnitude". The

meaning of the expression “kata megethos apeiron” (“infinite according to magnitude”) is not clear and requires clarification.

Among scholars on Zeno, the dominant interpretation of “kata megethos apeiron” is ‘a magnitude with infinite extent, e.g. a line with infinite length or a surface of infinite area.

Fraenkel (1975), pp.119-120, suggests that Zeno, in B1.2 and B1.3, deceived his readers consciously, by pretending that the mathematically false statement “every infinite sequence of positive terms diverges” is valid and true, while he knew that the opposite is true, because he needed to reach a contradiction.

Vlastos (1959), pp.169-170, and (1971), pp.233-237, disagrees only with Fraenkel’s interpretation of Zeno’s intentions, arguing that Zeno commits the logical error “every infinite sequence of positive terms diverges”, but without the element of conscious deception. Furley (1967), pp.358-9, also rejects Fraenkel’s opinion and in essence agrees with Vlastos.

So, all three scholars agree that Zeno, consciously or not, commits the logical error that “the sum of every infinite sequence of line segments is infinite in length”; and it is due to this mathematical error that a (seeming and artificial) contradiction is reached.

As will be explained, this conclusion is based on a misconception: these scholars, believed that with the expressions “apeiron megethos” (infinite magnitude), or “apeiron kata to megethos” or “megethei apeiron” (infinite as to magnitude), infinite length is implied in Simplicius’ ancient text. For the rendering of ancient terms, Fraenkel uses Aristotle, *Phusika* 206b34 and 206b7ff.

Simplicius explains that generally the term “apeiron to megethei” means magnitude which is composed of infinitely many magnitudes (“ex apeiron to plethei”- from infinite in multitude, 142,12-15). The similar expression “to megethei apeiron” means “ex apeiron to plethei megethon”-“ from infinite in multitude magnitudes” (575,23-24). Themistius agrees with this explanation in *eis Phusika* 91,29-30: “this which is composed of infinite is infinite according to magnitude”.

Simplicius, proceeding into a clearer description, defines “apeiron to megethos” as “apeira to plethei” “te aphe sunechizomena” (460,2-4), and the “apeiron megethos” as “apeira to plethei” “homogene...haptesthai allelon” (462,3-5). The touch and the continuity of infinite in multitude homogeneous magnitudes, is explained in detail as follows: “apeiron megethos” is created from “ta apeira to plethei te happe sunechizomena all’ouchi te henosei” (the infinite in multitude is infinite in the touch of continuation, but not infinite in union) (458,27-29); and, the “kata megethos” infinite is the infinite “te happe suneches...kai ou te henosei” (infinite by being continuous in touch, but not infinite in union) (459,20-26). After explaining the description of “kata megethos apeiron”, Simplicius adds, in this last passage, that if we have “apeira to plethei” (infinite in multitude) parts “megethos echonta” (having magnitude), which are “homoeide” (homogeneous, i.e. all line segments or all parts of the same circle etc.), and “haptesthai allelon” (touch one another), something possible exactly because they are of the same homogeneous, then an “infinite magnitude” which is “constant to touch” is produced. He also interprets Eudemus’ words, according to whom the “kata to

megethos apeiron” “ouden diapherei” (in no way differs) from “to kata plethos...omoeidei apeira” (the infinite in multitude of homogeneous entities).

The “ouchi te enosei” seems to exclude the interpretation of “apeiron kata to megethos” as magnitude of infinite length, but Simplicius in his attempt to leave no doubt, excludes infinite length in the most explicit way, in passage 508,19-509,20, according to which the infinite according to magnitude CANNOT possibly exceed some fixed given magnitude: “it is not possible to exceed every given magnitude” (‘hupervallein pantos megethos adunaton’), “does not exceed every magnitude”, “without exceeding every specific magnitude”, “it is impossible for it to exceed every specific magnitude”.

The misconception by Fraenkel, Vlastos, Furley among others, of the real meaning of “infinity according to magnitude”, resulted in the serious and persistent misconception that the ancient Greeks, and especially Zeno, erroneously believed that the sum of the infinite sequence of parts, each one of which is a straight segment with (positive) magnitude, has necessarily an infinite length!

We deduce that the notion ‘infinite according to magnitude’, for line segments, does not differ from the notion ‘infinite in multitude’ in any essential way, the only difference being that the infinite according to magnitude results from an infinite multitude of line segments, by attaching the end of the n^{th} line segment to the beginning of the $(n+1)^{\text{th}}$ line segment (for every natural number n) in one continuous line segment (of finite length, of course).

5.7. The anthyphairetic interpretation of fragment B1

Hence fragment B1 is interpreted as follows: If the many (sensible) are identical to the intelligible Beings, then every one of the sensible has magnitude (which is furthermore infinitely divisible) and is partless.

An intelligible Being is an initial whole, composed of two unequal parts. The anthyphairesis of these two parts, precisely because of the necessity for unity according to the initial Parmenidean demand that these parts be “the same” (‘tauta’), “similar” (‘homoia’) and hence “equal” (‘isa’), is characterized by the periodicity of the ratio (logos) of two successive parts. This is the reason why it runs ad infinitum. The infinity of anthyphairesis is described, according to our interpretation in 5.6, as “infinity according to magnitude”, but the periodicity makes the intelligible Being self-similar and “tauton heauto” and “partless”, since a magnitude by itself is certainly not self-similar with any part of itself. Self similarity and equalization of the unequal, as to magnitude, parts of anthyphairetic division, because of the periodicity of “ratio”-“logon”, explains the apparent peculiar appellation of argument B1 as a dichotomy argument.

Here, we must emphasize that the absurd does not consist in the fact that some being has magnitude and at the same time is without magnitude, as erroneously believed by Fraenkel and Vlastos. In fact every INTELLIGIBLE BEING is both infinite according to magnitude and without magnitude, as has been explained. The absurd which Zeno

reaches is that THE SENSIBLE BEINGS have these two qualities, and thus the hypothesis that the sensible are identical to the intelligible, exactly as Parmenides wished, is refuted.

6. The interpretation of Fragment B3

6.1. The translation of fragment B3 (140,27-34)

‘There is no need to labour the point; for such an argument is to be found in Zeno’s own book. For in his proof that, if there is plurality, the same things are both finite and infinite, Zeno writes the following words:’ [Lee (1936), p. 20]

‘If there are many things, they must necessarily be as many as they are, neither more nor less. And if they are as many as they are, they will be limited. If there are many things, the things that are are unlimited. For there are always other things between the things that are, and again other things between those, and thus the things that are are unlimited.’ [Fraenkel (1975), p. 103]

‘Thus he demonstrates numerical infinity by means of the argument from dichotomy.’ [Lee (1936), p. 20, fr11]

6.2. The correct meaning of the word “metaxu” (between) in Zeno’s fragment B3

In order to understand the second half of fragment B3, it is important to understand the sense in which Zeno uses the word between (‘metaxu’). By the most obvious interpretation something is “metaxu” two objects if it is intermediate and separates these two objects, in an implicit arrangement, and hence Zeno’s argument seems to be a “density” argument (e.g. the density of rational numbers means that given any two numbers, there will always be one between them), this which leads to infinite parts. And actually, this is the interpretation which Fraenkel and Vlastos give to the word “metaxu” in B3.

As we will see, the word “metaxu” has another meaning and is critical in the description of genesis in Plato, where one being is between two others, not if it separates these two things, but if this being consists of these two other things, and thus it is an offspring of these two.

In the *Phaedo* 71a12-b4, 71c6-7 two beings ‘enantia allelon’ (against each other), e.g. the major and the minor, (“hetera” in the *Sophistes*), give two “births” (geneseis), between (metaxu) these two beings. It is clear that the things which are “metaxu” initial beings of this birth, hold the role of offspring.

In the *Timaeus* 50c7-d4 the genesis is described as composed of the “other” (from which)-father, of the “en’ho” (in which)-mother and the “metaxu”-offspring produced. Again here we have a clear interpretation of “metaxu” as the offspring of genesis.

In the *Theaetetus* 153e4-a2, 157c6-158b8, 182a3-b7 the two opposite beings are “the active” light (or “swiftness”, quick) and “the passive” eye (or “slowness”, slow),

which fulfill the twin 'genesis' of "vision" and "color", each one of them characterized as "generated" ('gegenemenon', 'genomenon', 'gignomenon'), and "metaxu" the two initial parts.

The process of genesis is anthyphairetic, as has been shown in Negrepointis (2005): the passive part, let us call it a , is the slowness and corresponds to the major, because the major is the passive, as the divided part of anthyphairesis, while the active part, let us call it b , is swiftness, and corresponds to the minor, because the minor is the active, as the dividing part of anthyphairesis. The image, the offspring a_1 , of the intercourse of slow a and quick b , where as we saw $a > b$, is quicker, i.e. $b > a_1$, thus symbolically $a = b + a_1$, with $b > a_1$, an anthyphairetic relation. In the next stage of genesis, b , until then active, becomes passive, with respect to the quicker a_1 , and thus we have again $b = a_1 + b_1$, where $a_1 > b_1$, and b_1 is the offspring color. The twin offsprings, vision a_1 and color b_1 , are "metaxu" the parts of the initial dyad eye a and light b .

The meaning of "metaxu" as offspring of the (anthyphairetic) generation, is preserved by Simplicius, *eis Phusika*, in fragments 186,8-15 (where he explains that in genesis the "metaxu" are "not those separated by the two, but those generated by the two), 186,36-187,9 and 223,24-26 (where he describes "metaxu" exactly as in *Timaius* : "And we may liken the receiving principle to a mother, and the source or spring to a father, and the intermediate nature to a child", *Timaius* 50d, 2-4) (see also 284,9 and 313,16).

This interpretation of the "metaxu" beings, in fragment B3, as anthyphairetic offsprings, is reinforced by the fact that the "metaxu" beings are described as "other between" ('hetera metaxu'). The naming of anthyphairetic offsprings as "hetera", has already been analyzed in paragraph 5, in relation to fragment B1.

We conclude that the production of infinitely many parts in the second part of fragment B3, refers to infinite anthyphairesis, exactly as in fragment B1.

6.3. "tosauta... hosa", "peperasmena"

The first part of B3, attempts to prove that "if the many are (Beings)", i.e. if the sensibles are identical to the intelligible beings, then they must be finitely many in number. The proof is based in the fact that under this hypothesis, the sensibles "must be **just as many as** they are, and neither more nor less". It is not at all clear what exactly may be implied by this enigmatic sentence, and taken on its own will lead us with difficulty to anything substantial. But this changes as soon as we observe that this sentence is found almost identical in a crucial point of the second hypothesis in *Parmenides*, and specifically in 144d4-e3:

"Moreover, what is divisible must be as many as its parts...for it has not been distributed to more parts than unity, but to equally many; for what does not lack unity, and what is one does not lack being; the two are equal through everything."

In this passage, interpreted in Negrepointis (preprint b), Plato defines the dialectics "eiditikoï" numbers, i.e. the numbers which are composed of units which are equal and indivisible species (*Respublika* 522b-526c, *Philebus* 56c10-e6, *Politicus* 257a1-b8,

Aristotle's *Metaphusika* 1083a.17-b.8), especially the number two which is composed of units One and Being, which are clearly unequal because they are subject to anthyphairctic division (according to our examination in 5.5 above). However, Plato can conclude that the two parts One and Being "are equal through everything" ('*exisousthon duo onte aei para panta*'), and the one is not lacking over the other, because the parts of the One are equal to the parts of the other; this happens because the parts of the Being are as many ('*tosauta*') as ('*hosaper*') the parts of the One, and are therefore finite. From the anthyphairctic division of the indefinite dyad One Being, infinitely many parts for The One and also infinitely many parts for the Being can be produced. But, in what sense does Plato maintain that the parts of the One and the Being are finite and equal in number? The answer can be found in another passage of *Parmenides* (in the second hypothesis again), i.e. in passage 148d5-149d7, related with the contacts of units (*hapseis monadon*) in which the "eiditikoï" numbers are defined, as follows: Let $a_1 > a_2 > \dots > a_n > a_{n+1} > \dots$ the sequence of successive parts of Zenonian intelligible Being, as in fragment B1 (paragraph 5), with a_{n+1} the protruding part of a_n for every $n=1,2,\dots$. The parts of a_1 constitute the sequence $a_2 > \dots > a_n > a_{n+1} > \dots$, while the parts of a_2 the sequence $a_3 > \dots > a_n > a_{n+1} > \dots$. Since anthyphairesis is periodic, there is a natural number N so that the ratio (*logos*) a_1/a_2 is equal to the ratio a_N/a_{N+1} . According to the interpretation of passage 148d5-149d7 in *Parmenides*, in Negrepontis (preprint b), one "eiditikos" number consists of the number of contacts-ratio of successive parts of anthyphairesis + 1. Thus the ratio a_1/a_2 defines the "eiditikos" number two, with parts a_1 and a_2 as equalized units. The "logoi" $a_1/a_2, a_2/a_3, \dots, a_N/a_{N+1}$ are $N-1$ in number and hence define the "eiditikos" number N , with parts a_1, a_2, \dots, a_N as equalized units. The next "logos" a_N/a_{N+1} is equal to the initial a_1/a_2 , and thus cannot be employed as an additional unit to create a larger number. Hence the NUMBER of the parts of a_1 is the finite number N , as opposed to the infinitely many of his parts. Respectively, the fact that $N-1$ is the number of ratios different from each other $a_2/a_3, \dots, a_{N-1}/a_N, a_N/a_{N+1}$ proves that the NUMBER of parts of a_2 is also the finite number N . It is in precisely this sense that the parts of a_1 , finite in number, are as many as the parts of a_2 , as the parts of a_3, \dots as the parts of a_n , for every $n=1,2,\dots$.

The fact that "eiditikoï" numbers have been misinterpreted by studies of Plato's dialogue *Parmenides*, is evident, e.g. in Allen's interpretation [(1997), pp.250-260].

6.4. The anthyphairctic interpretation of fragment B3

Hence fragment B3 interpreted as follows:

If the many (sensible) are identical to intelligible beings, then each one of the sensible must have infinitely many parts and be finite.

Here we must emphasize, as in fragment B1, that here the contradiction does NOT lie with the fact that some being is finite and at the same time infinite, as is falsely believed by Fraenkel and Vlastos. Indeed any intelligible being must have the two properties at the same time. The contradiction which Zeno reaches lies with the fact that THE SENSIBLE BEINGS ('the many') are assumed to satisfy the two properties, and thus the hypothesis that the sensibles are identical to the intelligibles is proved to be wrong.

References

- Allen, R.E. (1997). *Plato's Parmenides*, Yale University Press.
- Barnes, J. (1986). *The Presocratic Philosophers*. London: Routledge & Kegan Paul.
- Coxon, A.H. (1986). *The fragments of Parmenides: a critical text with introduction, translation, the ancient testimonia and a commentary*, Assen, Netherlands: Van Gorcum.
- Diels, H. (1964). *Die Fragmente der Vorsokratiker*, Auflage herausgegeben von W. Kranz, Berlin, Druckerei Hildebrand.
- Fraenkel, H. (1975). *Zeno of Elea's attacks on plurality*, in *Studies in Presocratic Philosophy*, Vol. 2 (pp. 102-142), Allen R.E & Furley D.J. (ed.), London: Routledge & Kegan Paul.
- Furley, D. (1967). *Zeno and indivisible magnitudes*, in *Two studies in the Greek Atomists*, pp. 63-78, Princeton, N.J.: Princeton University Press. Reprinted in *The Presocratics*, pp. 353-67, Mourelatos, A.P.D (ed) Princeton, N.J.: Princeton University Press, (1998).
- Lee, H.D.P. (1936). *Zeno of Elea, A text, with translation and notes*, Cambridge University Press.
- Negrepointis, S. (1999). *Plato's dialectic under the anthyphairetic scrutiny*, in *Lectures, academic year 1996-97*, Philosophy Group of the University of Cyprus, edited by V. Syros, A. Kouris, E. Kalokairinou, Nicosia, 1999, pp. 15-58 [in Greek].
- Negrepointis, S. (2000). *The anthyphairetic nature of Plato's dialectics*, *Interdisciplinary approach to Mathematics and its teaching*, *Topics in Mathematics Education*, vol. V, Gutenberg, Athens, pp. 15-77 [in Greek].
- Negrepointis, S. (2005). *The Anthyphairetic Nature of the Platonic Principles of Infinite and Finite*, *Proceedings of the Fourth Mediterranean Conference on Mathematics Education*, 28-30 January 2005, Palermo, Italy, 3-26.
- Negrepointis, S. (manuscript a). *The reconstruction of the Pythagorean geometry and the resulting anthyphairetic interpretation of the Pythagorean philosophy and Zeno's dichotomy paradox*, to appear [in Greek].
- Negrepointis, S. (manuscript b). *The Periodic Anthyphairetic Nature of the One in the Second Hypothesis of the Parmenides 142b1-159b1*.
- Negrepointis, S. (manuscript c), *Plato's theory of Ideas is the philosophic equivalent of the theory of continued fraction expansions of lines commensurable in power only*, preprint, June 2006.
- Solmsen, F. (1971). *The tradition about Zeno of Elea re-examined*, *Phronesis* 16, 116-141. Reprinted in *The Presocratics*, pp. 368-393, Mourelatos, A.P.D (ed) Princeton, N.J.: Princeton University Press, (1993).

- Vlastos, G. (1959). *Review of Fraenkel's Wege und Formen fruhgriechischen Denkens*, Gnomon 31, 193ff. Reprinted in *Studies in Greek Philosophy. Vol.I: The Presocratics*, pp. 164-179, ed. D.W.Graham, Princeton, 1995.
- Vlastos, G. (1967). *Zeno of Elea*, P.Edwards (ed), *The Encyclopedia of Philosophy*, New York: Macmillan, vol. 8, pp. 369-379. Reprinted in *Studies in Greek Philosophy. Vol.I: The Presocratics*, pp.241-251, ed. D.W.Graham, Princeton, 1995.
- Vlastos, G. (1971). *A Zenonian argument against plurality*, J.P.Anton and G.L.Kustas (ed), *Essays in Ancient Greek Philosophy*, New York: S.U.N.Y. Press, pp. 119-144. Reprinted in *Studies in Greek Philosophy. Vol.I: The Presocratics*, pp.219-240, ed. D.W.Graham, Princeton, 1995.



‘Representation *per se*’ vs. ‘Representation as’, a useful Distinction for Mathematics Education

Demetris Portides

University of Cyprus

Abstract

What mathematical concepts represent and how they are represented in a given context are two distinct things that in this paper I argue that keeping them clearly apart is necessary to avoid obscuring mathematical processes. I tried to clarify the distinction and to demonstrate the logical differences between representation per se and ‘representation as’.

Introduction

Much enlightening empirical work in mathematics education has revealed a number of results of utmost interest and of much usefulness for. These include: how different representations of mathematical concepts facilitate problem solving (Elia *et al.* 2006, Elia *et al.* 2007), how students translate from one representation of a mathematical concept to another and the difficulties involved in these translations (Gagatsis & Shiakalli 2004, Artigue 1992, Hitt 1998), how multiple representations of the same mathematical concept is important and often essential to mathematical visualization and understanding (Duval 2002, Dufour-Janvier *et al.* 1987, Greeno & Hall 1997).¹

Despite the usefulness of such results I do want to raise caution regarding their interpretation, particularly my concern is that our interpretations would be much more refined and accurate if an important distinction is clarified. This distinction concerns what a representation *per se* is for mathematical concepts and propositions and how a ‘representation as...’ of a mathematical concept is used for, among other things, conceptualizing or visualizing a mathematical problem. In this paper I try to motivate

¹ In these approaches to the notion of representation, attention is confined to the application of mathematics in modeling physical problems or problems describing possible worldly situations. The problem of representation of a mathematical calculus and of how that affects inferences by manipulating the calculus, e.g. proving a theorem by the use of some axioms or other proven theorems, is not dealt with. Although the latter is, admittedly, a more difficult task, I do think that a correct understanding of the notion of representation is one that is involved in both the application of mathematical languages to different domains and pure derivation from the calculus.

this distinction and clarify some issues regarding the notion of representation in the light of the distinction.

The first element of the distinction concerns the deductive character of mathematics in general, the reference of mathematical propositions, and the nature of mathematical concepts, and it has been an issue for debate among philosophers and logicians for more than a century. The philosophical-logical debate derives its justification from the conviction that a mathematical representation *per se* is a canonical issue, and hence what mathematical terms represent (and the rules for making that representation) is a matter of learning for the mathematics student – in more or less the same manner as the language of mathematics is a matter of learning. In this paper, I shall spare the reader of the arguments of philosophical schools of thought on the issue, and I will restrict myself firstly in explaining what mathematical propositions are true of, hence what without qualifications they represent, and secondly to the less ambitious task of showing what a mathematical representation *per se* is not. By understanding what representation *per se* is not we can make sense of ‘representation as...’. The latter concerns our understanding of mathematical problems, our understanding of the particular mathematical concepts in question, and the particular ways by which we feel most comfortable for conceptualizing or visualizing the mathematical situation at hand. These are not canonical issues, they belong, by and large, to subjective aspects of human intelligence, hence empirical research is most welcome on this issue if it can help identify the different varieties of ‘representing as’, if it can help categorize these varieties and if it can help improve our understanding of how these categories of varieties can function in conceptualizing and visualizing different mathematical situations.

Clarifying the distinction

The distinction manifests its importance once we want to give an answer to two quite different questions: “What a mathematical concept or relation represents?” and ‘How a mathematical concept or relation is –or, more precisely, can be– represented?’ The first question demands an answer to what mathematical representation *per se* is and, it seems to me, it cannot be addressed by means of empirical investigations. Mathematical concepts refer to relations of numbers (or sets, or, more generally, abstract objects) hence whatever is represented by a mathematical concept belongs to the abstract realm of numbers and the relations defined upon numbers, or more generally to the realm of abstract mathematical objects and the relations defined upon those objects. The concept of ‘function’, for instance, represents a mapping from one set of abstract objects onto another such set, in other words what the function represents is the relation defined upon two distinct sets of abstract objects. In this sense ‘representation is a form of interpretation (as logicians would say), that is the function is given by means of a syntax (language) which is interpreted (i.e. its semantics is supplied) by understanding its terms to refer to the mapping between the sets. More accurately, if one is to use the language of logic, a mathematical proposition is satisfied by (i.e. is true of) a mathematical structure, which is another way of saying that it is satisfied by a set of objects and a set

of relations defined upon those objects. The different sets of abstract objects and relations that satisfy the given proposition is what the latter represents. Understanding our mathematical concepts and relations to represent anything other than sets of abstract objects and relations defined upon those sets, obscures the actual reference of mathematical languages and, in a sense, misguides the student of mathematics into thinking that mathematical languages are directly connected to the empirical world.²

The second question, i.e. “How a mathematical concept or relation can be represented?”, on the other hand, invites an answer to how a mathematical concept can be ‘represented as’ and it concerns our attempts to visualize the concept in a particular context for a particular problem solving task. The contextualization involved in this notion of representation implies that a number of features or consequences of the mathematical situation will be abstracted (i.e. ignored) in the ostensible representation. In the process of constructing such representations the goals are simplification and resemblance. We want to simplify the complexities of the concept or of the consequences of a mathematical syllogism by abstracting some features of the concept(s) for the purposes of fitting it to a particular application, and in doing this maintain some sort of resemblance to the initial situation. Both simplification by abstraction and resemblance are key notions to ‘representing as’. Abstraction (i.e. in its Aristotelian sense of subtracting some features of the actual situation at hand) is the conceptual process by which we achieve simplification without losing resemblance in relevant respects. Although it deserves an analysis of its own, I shall not occupy myself with the process of abstraction as it would lead me away from the central thesis of this paper. Analyzing the notion of resemblance is, however, important in order to see the philosophical underpinnings of the distinction I want to motivate.

What Representation per se is not

In much of the literature on representation in mathematics the notion of ‘resemblance’ or ‘similarity’ is considered a replica of some sort of the notion of ‘representation’. Possibly because it is a more mundane notion ‘resemblance’ makes the concept of ‘representation’ simpler to comprehend. However, as I have claimed above resemblance is only related to ‘representing as’ not to representation *per se*. Because the notion of ‘representation’ seems to be a vital component of mathematics (and the physical sciences) its characteristics must be carefully contrasted to its ostensible synonyms, before we can jump to the conclusion that the synonymy actually holds, otherwise we are led to miscomprehensions. It is not difficult to show that representation cannot be grounded in resemblance. For the two notions to be synonymous, and thus for representation to be reducible to the concept of resemblance, the following condition

² It may be the case that mathematics is not strictly speaking an *a priori* science after all, as some philosophical schools of thought would argue, but what is almost certain is that its link to the empirical world is far more complex and intricate than that implied by the naïve view that mathematical terms refer to empirical objects.

must hold: “X represents Y if and only if X resembles Y”. Where, X and Y are any two objects of any kind. This condition can be broken up to the conjunction of the following two conditions: (1) “if X resembles Y then X represents Y” and (2) “if X represents Y then X resembles Y”. Condition (1) expressed as a relation between X and Y states that “resemblance is a sufficient condition for representation” and condition (2) states that “resemblance is a necessary condition for representation”.

Nelson Goodman (1976) has shown that to hold the view that representation is synonymous to resemblance is a naïve view of representation *per se*. His argument shows that resemblance is neither a sufficient nor a necessary condition for representation. It is not a sufficient condition because resemblance is a reflexive and symmetric notion whereas representation is neither reflexive nor symmetric. That is to say, it makes sense to claim that X resembles itself (this is the highest degree of resemblance), but it does not make sense to claim that X represents itself at least not for all X. It also makes sense to claim that X resembles Y implies that Y resembles X, but it does not make sense to claim that X represents Y implies that Y represents X. In other words, when we use the notion of resemblance to make claims such as, Mary resembles her sister Helen we also mean that Helen resembles Mary in much the same way. On the other hand, when we use the notion of representation to make claims such as, Picasso’s Guernica represents the aftermath of the Nazi bombing of Guernica we do not mean that the aftermath of the Nazi bombing of Guernica represents Picasso’s Guernica. One could even extent Goodman’s argument and claim that resemblance is transitive whereas representation is not. That is to say, if X resembles Y and Y resembles Z then it makes sense to claim that X resembles Z. On the other hand, if X represents Y and Y represents Z then it does not imply the claim that X represents Z. Think of a painting depicting the photograph of Helen, of course it represents the photograph but it does not represent Helen. In other words, representing the means of representation of a target does not imply representing the target. Since the logical properties of the two concepts are clearly different it is not logically possible (i.e. without implicitly leading to contradiction) to use resemblance in order to explicate representation. Hence the position that the concept of resemblance provides the foundation for the concept of representation is groundless.

But can we claim that resemblance is a necessary condition for representation? If yes then every representation must appreciably resemble its target. Goodman’s answer is that we do not need any degree of resemblance to achieve representation. He claims, correctly I think, that almost anything can represent anything else. For instance, two stones on the ground can represent two armies ready for battle. That is to say, representation can be achieved even when the means of representing do not resemble in any way their target. I would even add that the mere concept of appreciable resemblance is context dependent, in the sense that it is relative to the domain of discourse. For instance, in the context of the Darwinian theory of Natural Selection ‘man’ appreciably resembles ‘ape’, whereas in the context of Newtonian Mechanics ‘man’ appreciably resembles ‘table’. Thus, the claim that resemblance is a necessary condition for

representation is not an assertion that admits generalization; it is dependent on the context dictated by the given discourse, and the latter's interpretation imposes psychological states from which the resemblances ensue. That is to say, because we interpret within a language that X represents Y we discern resemblance in some respects between the two objects. This conclusion is, I think, congruent with Goodman's conclusion that the core aspect of representation is denotation and thus it is independent of resemblance. It is also congruent with what I have been urging so far, that 'representing as' is correlated to resemblance. Because representing a mathematical concept *as* something of our choice is something we do in order to visualize it, thus resemblance is imposed from our part. Representation *per se* is, however, independent from resemblance; it is a product of our mathematical languages (i.e. any symbolic system) and their interpretation.

The fact that we use iconic (diagrammatic etc.) representations does not counter the above conclusion. Any picture can be described through a sufficiently rich language and not all linguistic expressions can be represented pictorially. The well known saying that "a picture is worth a thousand words" refers to the economy of thought and not to the representational power of the picture. Representationally speaking, "every linguistic expression conveys a thousand pictures". But, as in other domains of discourse, in Mathematics no matter how many pictures we use it is impossible to represent some of the things we do represent using the linguistic expressions of our mathematical concepts.

Some practical consequences of the distinction

Mathematics education researchers are interested (and rightly so), among other things, in understanding mathematical concepts in ways that facilitate practical applications. So far the distinction I have been urging seems to be of interest only for the philosophically minded. However, two characteristics, one attached to 'representation as' and one to 'representation *per se*', are of most valuable practical interest. The characteristic implied by the practice of 'representing as' is that the latter often implies counterfactual representation, i.e. X is represented as Y, could mean that Y acts *as if* it is a representation of X for a particular purpose but actually it is not, and often we know that it is not. That is, we may say that the triangle I drew in my notebook represents the concept of a mathematical isosceles triangle but it does not and, in fact, it cannot be what the concept represents. What we actually mean is that the drawn triangle acts as if it is a representation of the mathematical concept of isosceles triangle, i.e. the mathematical concept of isosceles triangle is represented as a drawn triangle. The drawn triangle acts as a representation because it resembles the mathematical concept in relevant respects and we do this because representing in diagrammatic form is one way by which we can simplify our mathematical syllogisms in particular problem solving tasks. Of course, I would be hesitant to generalize this observation, because there are cases where a particular concept is represented as something seemingly distinct, and the representation relation needs no 'as if' clause. Such is the case when we represent a mathematical function by means of a graph. The function is represented as a graph, and

not as if it is a graph of two variable quantities. The reason that such cases of ‘representation as’ exist, and in particular graphical representation is because what the function actually represents, i.e. a mapping between two sets of objects, can also be represented by the graph. In other words, there is what looks to be a direct translation between the syntactic form of the function and the graphical form which in fact is carried out via what they actually both represent. This, however, is not always as clear in all cases of translations from one ‘representation as’ to another, and this brings us to the characteristic attached to representation *per se*. In many cases we must look closely in order to make sense of how a translation is carried out. Nevertheless, one thing is always clear, that a translation from one ‘representation as’ to another is validated if both represent the same sets of objects and relations. In other words, ‘representation *per se*’ always mediates in translations. I am not claiming, here, that the translating agent consciously uses the representation *per se* to guide his/her translation, but that for a translation to be valid and non-arbitrary this condition must hold.

Both of these observations are, in my view, of practical interest to the mathematics educator. The practical significance stems from the synthesis of the following two things. Firstly that we know that a translation is valid when both representational systems refer to the same things (i.e. the same sets of objects and relations) and secondly we can empirically support the claim that understanding mathematical ideas entails: “(1) the ability to recognize an idea, which is embedded in a variety of qualitatively different representational systems, (2) the ability to manipulate the idea flexibly within given representational systems, and (3) the ability to translate the idea from one system to another accurately” [Gagatsis & Shiakalli 2004, pp. 645-646]. The first and second claims above, i.e. how an idea is embedded in a variety of qualitatively different representational systems, and manipulating the idea flexibly within given representational systems, are abilities that are fully acquired when the student recognizes that often we represent mathematical concepts *as if* they refer to things that actually they do not.

Conclusion

The philosophical underpinnings of the distinction between what mathematical concepts and propositions represent (representation *per se*) and how mathematical concepts can be represented (representation as), has been demonstrated. The distinction, as such, can be of usefulness to the Mathematics Educator, as the kinds of problems that arise in the learning of mathematics can be categorized in the light of this distinction, and treated appropriately. Clearly, the mundane notion of ‘representing as’ is embedded in ordinary thinking, and does not require mathematical maturity in order to comprehend and handle. In order to recognize that it is one thing to ‘represent as’ for the purposes of practical problems and it is another different thing for the abstract concepts of Mathematics to represent something also abstract, requires, however, mathematical maturity. And the question of when and how ‘representation *per se*’ can be taught effectively is a matter also of empirical research.

References

- Artigue, M. (1992), "Functions from an Algebraic and Graphical Point of View: Cognitive Difficulties and Teaching Practices". In E. Dubinsky & G. Harel (Eds.), *The Concept of Function. Aspects of Epistemology and Pedagogy* (pp. 109-132). Washington, D.C.: The Mathematical Association of America.
- Dufour-Janvier, B., Bednarz, N. & Belanger, M. (1987), "Pedagogical Considerations Concerning the Problem of Representation". In C. Janvier (Ed.), *Problems of Representation in the Teaching and Learning of Mathematics* (pp. 109-122). Hillsdale, NJ: Lawrence Erlbaum.
- Duval, R. (2002), "The Cognitive Analysis of Problems of Comprehension in the Learning of Mathematics". *Mediterranean Journal for Research in Mathematics Education*. 1(2), 1-16.
- Elia, I., Panaoura, A., Eracleous, A., and Gagatsis, A. 2006, "Relations Between Secondary Pupil's Conceptions about Functions and Problem Solving in Different Representations". *International Journal of Science and Mathematics Education*, 5, 533-556.
- Elia, I., Gagatsis, A., Demetriou, A. (2007), "The Effects of Different Modes of Representation on the Solution of One-step Additive Problems". *Learning and Instruction*, 17, 658-672.
- Gagatsis, A. & Shiakalli, M. (2004), "Ability to Translate from One Representation of the Concept of Function to Another and Mathematical Problem Solving". *Educational Psychology*, 24:5, 645-657.
- Goodman, N. (1976), *Languages of Art*. Indianapolis: Hackett Publishing Company.
- Greeno, J. G. & Hall, R. P. (1997), "Practicing Representation: Learning With and About Representational Forms. *Phi Delta Kappan*, 78,361-367.
- Hitt, F. (1998), "Difficulties in the Articulation of Different Representations Linked to the Concept of Function". *The Journal of Mathematical Behavior*, 17, 123-134.



Different procedures in argumentation and conjecturation in primary school: An experience with Chinese students

Benedetto Di Paola & Filippo Spagnolo

G.R.I.M. (Research group into the teaching of mathematics)
Department of Mathematics and Applications, University of Palermo

Abstract

As it is possible to read from numerous research studies (Spagnolo, 2005; Nisbet, 2001, 2003) the reasoning schemes and the cognitive process specifically referred to the argumentation, conjecturation and demonstration phases are not possible to be defined in a universal way without taking into consideration the cultural context in which people live and study (linguistic aspects, philosophical aspects, beliefs and values etc.). This characteristic is evident in a clear manner analyzing different cultures as the Italian and the Chinese. The article aims to augment, in an experimental way, as some of the cultural differences verified through the Italian and Chinese cultures (we will refer to the epistemological aspect of the two cultures) tacitly influence the didactical sphere of the discipline, putting in evidence differences in the basic nature of the cognitive process utilized by the students. The didactical experience discussed in this work, conducted in multicultural classes in Palermo, aims to analyze the cognitive behavior of pupils aged 3-10 in resolving pre-algebraic problems. The present work is inserted in a broader research project, conducted within the GRIM of Palermo and essentially dedicated to the analysis of the logical argumentative schemes verified in the Chinese and Italian cultures in the resolution of different task (tips of solution, resolute algorithmic, verifiable errors) structured in diverse mathematical contexts, created ad hoc. As for the research methodology, the activity was conducted according to Brousseau's theoretical framework. The selected concept that constituted the mathematical specific milieu was choice in relation to the arithmetical thought, the algebraic thought, and so to the first approach to the concept of variable and unknown. The collected data have been analyzed in parallel according to a quantitative and qualitative analysis. Quantitative analysis has been conducted using the software CHIC 3.0 for non parametric statistics.

Introduction

What we analyze when we discuss about the binomials *mathematics-culture*, fundamental relation for this work and for a large tradition of research in didactic of mathematics, is not only the presentation of specific techniques through which a certain group of people treat the mathematical knowledge; but a critic discussion of possible correlations between the cultural context on which these people live and the treated mathematical concepts that are elaborated and obtained. This is the approach that we are following, even if in a first approximation, in our work. What we are interesting in is in

fact the analysis of the reasoning schemes adopted by the student and strictly interpreted in relation to particular aspects of their own culture; with particular attention on the logical-linguistic problems.

For what we said before and with the aim to discuss the treated problematic, we think that could be useful to present briefly:

1. the role of the history of mathematics as an instrument of observation and analysis of multicultural learning/teaching situations: the case of the Nine Chapter as canon for the construction of mathematics (1st Cent. B.C.-1st Cent. A.D.);

2. the role of natural language in the development of mathematics in the history of thought. (Spagnolo, 1996, 2002);

3. the role of fuzzy logic (an approach of the linguistic type) as an interpretive instrument for the Chinese students of some problem situations in class correlated to “common sense” (Spagnolo, 2002, 2005). The main references are those of Zadeh, (as regards the fundamental considerations of fuzzy logic of the linguistic approach) and of Kosko (1995) as regards the relationships and analogies identified between fuzzy logic and oriental thinking.

The first of the reference, the *historic and historic-epistemological analysis of mathematical thinking*, according to us, could be useful to study the different patterns of reasoning (deducing, conjecturing, demonstrating) in the European and Chinese cultures. This kind of analysis is conducted with the typical argumentations of history and epistemology and it is the basic reference for all the work. In this specific case we are discussing to the principal reference for mathematics in Chinese education: the “Nine Chapters on Mathematical Procedures”.

The second and the third reference specifically refer to the initial acquisition of “symbols” and variable (in a pre-algebraic sense) in children and so an interpretation of the reasoning scheme referred to this.

The “Nine Chapters on Mathematical Art (Jiuzhang suanshu)”, typical Chinese reasoning schemes and possible East Asian Identity in Mathematics Education.

The *Jiuzhang suanshu* or Nine Chapters on the Mathematical Art is a practical handbook of mathematics consisting of 246 everyday problems of engineering, surveying, trade, and taxation. It played a fundamental role in the development of mathematics in China, not dissimilar to the role of Euclid's Elements in the western mathematics. It is so principal reference for mathematics in Chinese education, a canon both for the construction of mathematics (1st Cent. B.C.-1st Cent. A.D.) and for the teaching/learning of the same in the various historic periods. Among the most notable is the commentary of Liu Hui (263 A.D.) presented in the collection of the Mathematical Canons of the Tang Dynasty (618-907 A.D.). Let us now give a short description of each of the nine chapters of the book.

Different procedures in argumentation and conjecturation in primary school

Chapter 1: Land Surveying.	This consists of 38 problems on land surveying. It looks first at area problems (the types of shapes for which the area is calculated includes triangles, rectangles, circles, trapeziums), at rules for the addition, subtraction, multiplication and division of fractions. The Euclidean algorithm method for finding the greatest common divisor of two numbers is also presented. In the problem number 32 an accurate approximation is given for π .
Chapter 2: Millet and Rice.	This chapter contains 46 problems concerning the exchange rates among twenty different types of grains, beans, and seeds. It possible to find a study of proportion and percentages and an introduction of the rule of three for solving proportion problems. Many of the treated problems apply as simple exercise to give to the reader the practice to work with the calculations with fractions.
Chapter 3: Distribution by Proportion.	There are 20 problems which involve proportion (direct proportion, inverse proportion and compound proportion). In particular arithmetic and geometric progressions are used in some of the problems.
Chapter 4: Short Width.	24 problems (the first eleven problems take the name to the chapter). Problems 12 to 18 involve the extraction of square roots, and the remaining problems involve the extraction of cube roots. Notions of limits and infinitesimals appear also in this chapter.
Chapter 5: Civil Engineering.	28 problems on construction of canals, ditches, dykes, etc. it is possible to find volumes of solids such as prisms, pyramids, tetrahedrons, wedges, cylinders and truncated cones Liu Hui, in his commentary, discusses a "method of exhaustion" that he invented to find the correct formula for the volume of a pyramid.
Chapter 6: Fair Distribution of Goods.	This chapter contains 28 problems involving ratio and proportion. The problems refer to travelling, taxation, sharing etc.
Chapter 7: Excess and Deficit.	20 problems that report the rule of double false position.

<p>Chapter 8: Calculation by Square Tables.</p>	<p>This chapter contains 18 problems which are reduced to solving systems of simultaneous linear equations. However the method given is basically that of solving the system using the augmented matrix of coefficients. The problems involve up to six equations in six unknowns and the only difference with the modern method is that the coefficients are placed in columns rather than rows. The matrix is so reduced to triangular form, using elementary column operations as is done today in the method of <i>Gaussian elimination</i>, and the answer interpreted for the original problem. Negative numbers are used in the matrix and the chapter includes rules to compute with them.</p>
<p>Chapter 9: Right angled triangles.</p>	<p>In this final chapter there are 24 problems which are all based on right angled triangles. The first 13 problems are solved using an application of Pythagoras's theorem, which the Chinese knew as the <i>Gougu</i> rule.</p>

The key concept that organizes the description of the Jiuzhang suanshu is the concept of “class” or “category” (*lei*) that plays a fundamental role in the commentaries. The elements that we find relevant to understand the specificity of the book and so of the related culture are so: the *problems* and so the typology of the problematic situation putted on the book and judged relevant for the Chinese culture for the time of the book, the *modus operandi* described in the book (the “procedure” (*shu*), the algorithmics in the term sense intended by Chemla (2004, 2007) that are useful to classify, understand and so describe the categories), the *calculus instruments*, the *demonstrations* (in the Chinese sense of term), the *epistemological values*.

The structure of the book is gradually articulated from the simple given of a problem (*wen*) related to a particular category, to solve it, “generalizing” step by step, trough an *analogical* reasoning, trough a *variable mutation*¹, the proposed situation and defining hence a general solution strictly connected to the proposed contest in a holistic vision (Nisbet, 2001). So, it is through a work on the procedure that is possible to define the situation classes. The solution process is an abtuitive process where deduction and

¹ According with the Chinese philosophy in which nothing is clear divided in white and black, neither the colors interpreting the circle *Ying e Yang*. “The oriental dialectic welcome the possible contradiction inside on a logic reasoning since only trough these the verity is known. (Nisbett, 2003). The fundamental principles that regulate the oriental dialectic are so verifiable on:

- a) Principle of mutation: the reality is a process subjected to a constant mutation;
- b) Principle of contradiction: since the mutation is constant, the contradiction is also constant;
- c) holistic principle: since all the thing varying continually and it is always in contradiction, nothing, in the human life as

in nature, is possible to understand independently. All is linked.

All gave them the possibility to tolerate the paradox, it isn't absolutely absent in the western culture.

induction are together in a unique reasoning scheme. The perfection is defined in terms of simplicity and generality through a global vision of the problematic.

As Nisbet declares *“The social worlds of East and West today reflect to a substantial degree their origin in Chinese and Greek culture, respectively...the social differences influence cognitive processes...we might expect to find cognitive differences among contemporary peoples that parallel those found in ancient times.*

Some of the differences that Nisbet puts in evidence are:

-the relationship between the field and the object, and the perceived relations among events;

-the organization into categories and covering rules, instead of organizing in terms of similarities and relationships (typical for the Chinese culture);

-apparent contradictions, Westerners resolve the situation by deciding which of the two propositions is correct, whereas Easterners are inclined to find some truth in both propositions. Westerners thus emphasize non-contradiction, whereas Easterners value the “Middle Way.”.

Trying to define an universal identity for the features of the East Asian mathematics education with the underlying values in contrast to features and values in the West, Leung in the ICME-9 in Tokyo/Makuhari, Japan, 2000, defined six interesting dichotomies that, according to us, are strictly linked with the other two aspects presented before about the natural written Chinese language and the role of fuzzy logic (an approach of the linguistic type) as interpretive instrument of some problematic situations correlated to the “common sense:

1. Product (content) versus process;
2. Rote learning versus meaningful learning: *“Understanding is not a yes or no matter, but a process or a continuum”*
3. Studying hard versus enjoying the study *“the East Asian view is that learning or studying is necessarily accompanied by hard work, and a deeper level of pleasure or satisfaction is derived only as an end result of the hard work”*
4. Extrinsic versus intrinsic motivation
5. Whole class teaching versus individualized learning *“Chinese proverb: teaching students in accordance with their aptitude”*
6. Competence of teachers: subject matter versus pedagogy.

Observations on the Chinese written language

For the observations regarding language we are referring to the research works of Chemla (2001), Needman (1981) and Granet (1988).

As Granet declares

“Chinese was able to become a powerful language of civilization and a great literary language without having to worry about either phonetic wealth or graphic convenience, without even trying to create an abstract material of expressions or supplying itself with a syntactic armament. It managed to maintain for its words and sentences a completely concrete emblematic value. It knew how to reserve only for rhythm the care of organizing the expression of thought. As if,

above all, it wanted to liberate the spirit from the fear that ideas can become sterile if expressed mechanically and economically, the Chinese language refused to offer these convenient instruments of specification and apparent coordination which abstract signs and grammatical artifices are. It kept itself obstinately rebellious against formal precisions for the love of the concrete, synthetic adequate expression. Chinese does not seem organized for noting concepts, analyzing ideas or conversationally expressing doctrines. In its completeness, it is constructed for communicating sentimental behaviors, for suggesting conduct, for convincing, for converting.” (Granet, 1988, p.243)

The words are nouns (*ming*) that refer to “existing things” (*wu*) in effective reality (*shi*). As an example we could consider the word that means “old”. It does not exist; in compensation there is a great number of terms which illustrate different aspects of old age, with a full series of subtleties. The Chinese character to express the meaning of “old” is [lǎo] in which . is for . *huà* “change”. . *máo* means “hair”. "The modern form is an extreme corruption of a seal containing . hair . changing (color): old" (Karlgrén, 2002).

The construction of the ideograms are classified in different categories or “*meta-rules*” of composition. The ideogram presented, in the Chinese writing, is one of the composition rules of the fundamental characters. Needham reports the classification in six classes and he discuss them in this way:

a) *Hsiang hsing*, lett. «Forms of imagines» (pictograms): *tree* .; *sun* .; *moon* .; *mountain* .; *horse* .; *bird* .; *crow* □ (it like . “bird”, but missing the dot in the head; the eye is invisible because a crow's eye is black like the feathers);

b) *Chih shih*, lett. «Indicators of situation» (indirect symbols);

c) *Hui i*, lett. «Union of ideas» (composition by association or logic composition). 80% of the ideograms are of the associative kind (Needham, 1981). They represent a sort of mental equations as semantic combinations of two or more characters that are composed by association. We could find different examples for this:

- . [nán] *man* = . (*tián*) “field” + . (*lì*) “strength.

Such equations constitute a semiconscious mental foundation for whoever is acquiring familiarity with the language.” (Needham,

- □ [hǎo] *good* = □ (*nǚ*) “woman” and □ (*zǐ*) “chil

The two components combine to represent the meanings “good” and “like”;

- . [lín] (.. *sēnlín*) forest = *tree* . + *tree* . (plus .). Two . (*mù*) trees side by side.

- . [xiū] *stop, rest* = (. *rén*) + . (*mù*) *tree*. A person stopping to rest under a tree.

d) *Chuan chu*, lett. «Transferable sense» (symbols that is possible to interpret reciprocally).

e) *Hsing sheng*, lett. «Language or sound». These characters are defined in a determinate general manner: the radical is associated to a phonetic sign to indicate the category on which we have to find the meaning of the word. So a lot of words with the same sound are written without confusion. (Needham, 1981, p. 38).

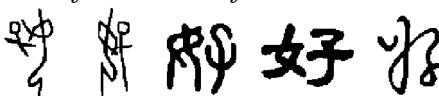

- [yuán] *garden* = . (wéi) “surround”, suggesting a garden fence, and (full form:) . yuán phonetic or (simple form:) . yuán phonetic;
- . yuán or (simple form:) . yuán phonetic, and . (chuò) “go” (to go far) = “far”
- f) *Chia chieh*, lett. «Loan» (caratteri fonetici in prestito). The formation is much similar to the precedent case but the way to construct the character is different.

Equal definition is reported on all the Chinese grammatical in different volumes on the history of Science in China as in the volumes of Enciclopedia Treccani (1977).

Other two transversal interesting observation could be made regarding the reasoning scheme to the written Chinese language:

a) the use of the contradiction in a contemporary of the opposites (From the point of view of Fuzzy Logic²) inside the language:

- . [bēi] *cup*: from . (mù) “wood” and . bù “not” phonetic. From the association of these two characters and so from the idea of “opposition/contrast” born the concept of cup: *Everybody knows that cups are □ (not) made of □ (wood)*.

- From . bù “no” and . kǒu “mouth” we find the character linked with the idea of *not to use the mouth*.

b) the idea of a variable (as thing that varying) and a parametric system inside the composition of many characters. Some simple examples could be:

- *Gǔ* (.) = as unitary ideograms “old” composed by “ten” and “mouth” (in reference to the Chinese philosophy That which has passed through . ten . mouths, i.e. a tradition dating back ten generations) strictly linked to other different characters linked with it by a semantic or phonetic units:

- . = *to harden* (annoyed and hardened), with the radical 31: .

- . = *to fade* (annoyed and done harden) “From . (mù) “tree” and . gǔ (“old”) phonetic. . “old” also it is suggested the meaning, “withered”

- . = *reason, cause* (aged, dried him and fixed him) with the radical 66

- . = *mother-in-law* (elderly woman “dried him”) with the radical 66 to the left.

- . = *solid thing and hardened,*

- (. = *old men*)

Another example in this sense could be with regard to the radical . (tián) “field”. We could find other 138 different characters linked with it:

- . [lǐ] “village”: From □ (tián) ‘field’ and □ (tǔ) ‘earth’. “Village of 25 or 50 families; place of residence; (the length of the side of the said village:) length measure of about 600 meters” Since the adoption of the metric system, a lǐ is exactly 500 meters. The word lǐ meaning ‘inside’ in its full form is written with □ and □ (yī) ‘clothing’, either □, split with □ on top and the rest below, or □, with □(□) on the left side. The simple form is just □ without □ (Karlgren, 2002)

- . [guǒ] “fruit”: field + tree

² A set A and the set not-A have in fuzzy logic an intersection which varies from a minimum to a maximum that depends on the possibility of receiving A and not-A and distinguishing A and not-A.

- [jiè] “boundary”: From 田 (tián) 'field' and 介 jiè 'introduce'. According to Karlgren, 介 jiè is etymologically the same word as 界 jiè, which originally also meant 'boundary'.

- [sī] (.. sīxiǎng) “thought”: The top depicted a brain, now it happens to look like 田 tián 'field'. The bottom is 心 (xīn) 'heart'.

-(F.) [bèi] (..) “get ready”, “prepare”; .. “equipment”: The explanation of 备 is obscure. There have been numerous different forms, including the full form 備 and the simple form 备. Mnemonic for 备: 备 (zhǐ) walk slowly around a 田 (tián) field, preparing equipment?

- [liú] “stay”; .. “hand down”; .. “arrest”: From 留 (liú) mǎo phonetic and 田 (tián) 'field'.

-(F.) [huà] “draw”; “picture”: “Draw boundary lines...delineate, draw, paint; drawing, painting; stroke (in writing) -- 画 to draw 田 or 田 lines: boundaries of a 田 field” (Karlgren, 2002).

An old form is 畺. In the common full form 田, the bottom 田 is reduced to 田. In the simple form 田 the top 田 is left out. Compare 田 (田) zhòu which is similar to 田 (田) in the full form.

These characteristics of the written language seem to put in evidence an internal research to a use of a common strategy to define “different characters” in which the radicals part assume a role of a parameter (in a mathematical sense of the terms) and vehicle the meaning or the sound of the character. It seems to us a sort of research of a possible *fundamental algorithmic* to construct different “words” and so to read and to write these in a continuous parallelism, in a continuous relationship, between “serial thought” and “global thought” on each single character.

Ex: **Algebra** = 人 = 人 (to represent) + 一 (number) = [人 (men) + 一 (an arrow that points out: it represents the phonetic part)] + [一 (clapping, tapping rhythmically to facilitate in counting) + 一 (“that is obscure”)]

The ideogram is formed therefore from two meaningful parts that give a new meaning, but at the same time one of the parts also has phonetic value and it communicates the sound.

This observation seems to us to argue how the reasoning pattern inducted from the written natural language brings naturally, unconsciously, the Chinese people to use (in different contest) some pre-algebraic reasoning schemes.

Some reflections on “arguing, conjecturing and demonstrating” in Chinese Culture with relation to Occidental Culture.

This paragraph briefly analyses, in a schematic way, some substantial differences founded in the history of the Chinese and Western thought.

Different procedures in argumentation and conjecturation in primary school

In the comparative analysis of science in pre-modern China and the west, Geoffrey E.R. Lloyd (2001, pag.574) says that, “The aspirations of ancient Greek tradition represented by Euclid, which proposed deducing all mathematics from a single set of indemonstrable but evident axioms were not shared by the Chinese at least until the modern age. In China, as a matter of fact, the goal was not axiomatic-deductive demonstration, but gathering unifying principles from all of mathematics.”

The following table analyses some differences in reasoning patterns in a holistic vision.

Occident	Orient
1200 algebra: no formalization	200 B.C. algebra: no formalization
Paradigm of geometry, Equations	Positional system, matrices (system of the rods)
Aprioristic formulas that hide the processes, favoring, with the result, determinism	Solving equations by means of algebraic manipulations with the strategies: 1) making equals, 2) making homogeneous, 3) research for fundamental algorithms.
Reduction ad absurdum in a potential infinite	Existing infinity of operations

What we focus on in this work is the algorithmic aspect and the holistic thought that transpire from the Chinese culture, as it is possible to read through the table and in relation to what we said before about the historical mathematical reference of the *Jiuzhang suanshu*. According to us and to other research work in the didactics of mathematics, it is in fact one of the main reference for the Chinese mathematical thinking and so for the procedures in argumentation, conjecturation and demonstration. It plays a central role in the Canon of mathematics and also represents a tool to demonstrate. In problem solving, the concept of variable varies and permits, after different steps (algorithmic strategy), to find the unknown value that has to be obtained in the problem. This process for the solution is standard and it is therefore an algorithm. Demonstrating the validity of that reasoning means demonstrating the correctness of the procedure (use of the properties of the operations) in the steps of the algorithm. Thus, the algorithm is a combination of an iteration and of chosen ‘conditionals’. The chosen conditional is a first interesting element of the pattern of reasoning: *Iteration*; *Conditionals (If...then...)*; *Assignment of variables*.

The following table attempts to find analogies and differences between the meanings that the algorithm assumes in the two cultures.

	<i>From the occidental point of view:</i>	<i>From the oriental point of view</i>
<i>Intuitive algorithm</i>	Procedure	Procedure. Research of fundamental algorithms as reference.
<i>Formalized algorithm</i>	Algorithm: 1) Effectiveness, actually feasible by an automaton. The automaton must be able to recognize the minimum parts of the description of the algorithm (accepting the language in which the algorithm is written; the well formed sentences are called instructions). 2) Finiteness of expression: finite succession of instructions. Cycles, conditions, jumps. 3) Finiteness of the calculation: in the concept of algorithm there is usually included the condition of termination of the procedure for any situation of initial data within a certain domain. 4) Determinism: at each step of the execution of the procedure one and only one operation must be defined and successively carried out.	A paradigmatic example is the “rule of three”: the rule of three rests on the “quantity of that which one has” and on the pair constructed from the “ <i>lū</i> of that which one has” and of the “ <i>lū</i> of that which one is looking for” to give rise to the “quantity that one is looking for”.
<i>Deterministic algorithm</i>	Condition 1 is inalienable. The others give rise to different types of algorithms. If 4 is missing, the algorithm is called non-deterministic.	Research toward analogies of valid algorithms for classes of homogeneous problems. Reference to the algorithms as true and real models.
<i>Probabilistic algorithms</i>	Approximate, probabilistic, NP-complete algorithms (if there exists a polynomial algorithm able to confirm whether or not this is effectively the solution of the problem), algorithms that stop after a number of steps which grows exponentially.	Fuzzy algorithms?

In this sense, the algorithm seems as an instrument for demonstrating the precision of an argument (in the *Jiuzhang suanshu* each argument is concluded with phrases of this type “*from here the result*”).

Through this cultural aspect another stable reasoning pattern in the Chinese culture is possibly defined: the continuous research to the strategy to “Making homogeneous and making equal”: (from the commentaries of Liu Hui, 263 B.C. (Chemla, 2001, pg. 142))

“*Making equal*” and “*making homogeneous*” are strategies of reference to be able to concretize the correctness of the reasoning through an algorithm and it could present, according to us, concrete indications on algebraic manipulations of formulas.

An interesting example of the “*Making homogeneous and making equal*” is that of the *rule of three* (from the commentaries of Li Chunfeng, 656 B.C. (Chemla, 2001, pg. 142). This algorithm once again is an operation which “*makes equal*” and “*makes homogeneous*” (in the reduction to unity). So, the rule of three, as a fundamental algorithm, is the parallel in western culture of the postulate. The fundamental algorithm can combine itself several times always arriving at a sure argument.

As Liu Hui observes, in this joke of relationships between “serial thought” and “global thought” in reading and understanding a problem, particular attention must be given to the examination of the algorithm on the classes of problems, to be able to highlight its correctness.

An experience with Italian and Chinese students: theoretical framework

One of the open problems of the “new” school is to interpret the behavior of students introduced into multicultural classes. In Italy, the issue of “multi-cultural” classes is a phenomenon that, even though rather new, it is in wide expansion: the integration of foreign students in the Italian classes had, in the recent years, an increasing rate and has become no more an exception but, on the contrary, an inevitable reality. «*The present situation requires therefore to consider and to reorganize an idea of education in balance with the new needs and resources, in order to strengthen the trend of differences integration, the change and mutual adaptation, an open trial correlated with identities recognition and acceptance and with incorporated knowledge*» (Canevaro 1983).

The differences that could be detected in the class activities from this point of view, will turn into sources that enrich the whole class. In these relationships, the teacher has to play the essential role of a “knowledge mediator”. In the specific case of Mathematics, a greater attention was paid in recent years to the problems of the didactics in a multicultural school milieu and these themes were included into several school programs and described in many papers. It becomes evident in this context, that the starting point of any activity facing problems which have arisen out of the presence of cultural differences in the class, is to specify and highlight all moments that characterize cultural models of integration: pupil’s previous knowledge, his motivations, his expectations and abilities, his personal and intellectual characteristics; all that constitutes the necessary prerequisites of every correct pedagogic intervention. (Garcia Hoz-Guerriero-Di Nuovo-Zanniello 2000).

The research activity we propose in this paper belongs to this context. Specifically, it proposes a reflection on teaching/learning methodologies of the concept variable/unknown and therefore on their understanding (augmenting and conjecturing in natural language but not only) in primary school pupils involved in experiments

(Chinese and Italian pupils). As we said before, the problem regarding the sense of variable could be connected with some particular aspects of the Chinese culture, for example the structure of the ideograms in the written Chinese language and the logical-argumentative schemes adopted by the Chinese students in the class. It is also connected (this is the aim of the project in which this research is inserted) with the difficulty to delineate a general framework that can allow to individualize the fundamental steps for the development of the algebraic thought in relationship to the arithmetical and geometrical ones.

In this context, research at national and international level underlines the complex problematic regarding the passage from the arithmetical thought to the algebraic thought and so the birth and the evolution of the sense of the concept of variable for the students. In the phase of transition between arithmetical thought and algebraic thought, they verify then as some epistemological obstacles strictly connected to the passage from a meaningful semantic field, precedent, (the arithmetic) and the syntactic construction of a new language (the algebraic one) can delay the development of the algebraic language and so the algebraic thought. (Spagnolo, 2002)

These experimental analysis allowed us to underline a different behavior of the students in relationship to: the logical structure of the proposed problematic situation, the type of study course attended and the origin country (different culture, different system education, different teaching's strategies...). Thus, one of the open problems is to interpret the obtained results, in presence of multicultural classes.

The choice to study the Chinese mathematical thought is, as we just said before, due to the fact that the Chinese culture, as regards Natural Language, Philosophy, Logic etc., is the most distant from the western culture; to analyze the reasoning schemes used by the Chinese student in the resolution of a mathematical problem allows us not only to reflect on the differences of argumentation adopted in the two countries in the resolution of a same assignment but, above all, it allows us to reflect on our cultural reference system, the Western one.

- Do the Italian and Chinese students, in the resolution of particular problems, put in evidence different resolution strategies reported to the effect of their origin culture (Natural Language, logical-argumentative schemes, algorithms, etc...)?
- Is it possible to underline these differences analyzing their argumentation and conjecturation on in the passage from the arithmetic thought to the algebraic thought?
- Can the study of such differences help the understanding of the phenomenon of teaching/learning in multicultural situation?

To be able to interpret the comparative study between the Chinese thought and the Italian one in situations of teaching/learning in a multicultural perspective, we are referring to the studies of J. G. Gheverghese (1987) and U. D'Ambrosio (2002).

The principal theoretical reference for the methodology of the study is Brousseau's theory of the situations (Brousseau 1998); in a multicultural milieu it could result central in the specific phase of socialization of the cognitive styles. To put in evidence the socialization of the cognitive styles (*phase of validation* of the a-didactic situation) became then the carrying element for the comprehension of the phenomenon.

Having accepted the principle that education comes to be "realized" around the student, considering then the social and physical milieu in which he lives, the Didactics of Mathematics has to build on the different experiences offered by the contemporary presence in class of different cultures, each one with the own mathematical inheritance and mathematical knowledge, to a cultural exchange and a mutual enrichment.

The topic we deal with allows also a series of transversal theoretical reflections that need to a consider as broad as possible frame of reference that considers not only motivation/emotional side of the didactical activities but also the role of such a didactical methodology, centered on playing and creative activities. (Piaget, 1976, Brousseau, 1998), that "disrupts" that pre-arranged context expected and feared by the pupil in which he carries out mathematics.

Methodology and first results

The problematic situation on witch we are referring on this paper is a particular game, experimented with Chinese children of infancy and elementary school, *Sudoku/Magic box* opportunely simplified.

The game is the *box/matrix* shown in the figure aside.

We proposed it in the classroom with other five different images of animals on the cards and a series of rules for the composition/solution of it:

1. each animal cannot be in the same line or column with its enemy

(we presented the enemy animals);

2. each animal has to appear in the square only once;

3. each student has to insert in the box, all of the nine possible different

Animals shown in the image cards;

4. the solution has to be only one.

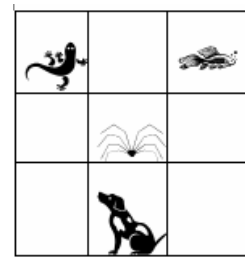

This is one of the possible games for a first approximation research, conducted in a multicultural milieu with Chinese students and also pupils from other countries, into the relationships between the "serial thought" and the "global thought" in the reading and understanding of the problem. In a first approximation, we could consider, this kind of reasoning connected to the arithmetical and algebraic thinking and their relationship.

We involved in the experiment about 95 children (13 Chinese students) aged 3-10; the age range was chosen to investigate in the broadest possible way the different behaviors and different verbalizations of the pupils in this situation.

The experimentation was divided in two phases:

1. situation/game with children of the infancy School "Ferrara" of Palermo and of the of the Primary School "Costa G." of Palermo, first two years, to observe through quantitative and qualitative analysis (classroom experiences videotaped), the behaviors enacted by the students and the different playing strategies and the recurrent reasoning of Italian and Chinese students;

2. Semi-structured interviews (videotaped) to two foreign (Chinese) students, inserted in the Sicilian scholastic context at the Elementary school, regarding the same situation/game.

As we previously said the game was chosen and adapted according to a series of critical reflections and research previously carried out within the GRIM on the same topic. To structure the game, we considered some of the particular linguistic aspects that characterize the structures of Chinese written language and in particular the possibility to interpret an ideogram as union of single elements (local vision, *Western vision*) or/and unitary character (global vision, *Chinese vision*), the possibility to find a first approach to the sense of variable inside the written Chinese language and also some of the typical reasoning schemes discussed before and referred to an algorithmic approach to the solution of a mathematical problem including “one problem multiple solutions,” “multiple problems one solution,” and “one problem multiple changes.” (Cai, 1999, 2007)

The selected data, is analyzed both quantitatively, through the analysis of the protocol, and qualitatively with single case studies. For the quantitative analysis we used the software for inferential statistic Chic 3.0 (Classification Hiérarchique Implicative et Cohésitive).

Trough this quantitative analysis of the collected data, shown in the presentation of the article, the proposed game will be examined in relationship to the results underlined previously in other relevant works (realized in other different mathematical contexts) conducted in multicultural milieu with Chinese student of different ages; research work realized within the GRIM.

In this sense, the game of *Sudoku/Magic Box* seems to confirm, even though it is a first approximation, results previously discussed in other research works: compared to Italian students, Chinese pupils present a different kind of logic in the following items: problem reading data, data organization, “type” of language used to describe the solution and hence different schemes of reasoning in argumentation and conjecturation.

We can therefore consider the situation/game as a first good instrument of investigation of the argumentation, conjecturation and demonstration ability of the involved students. In particular, the collected data relative to the Chinese students, seem to confirm a concrete, pragmatic behavior, already highlighted in the works of Chemla (2001) and Spagnolo (2002); behaviors strictly bound to procedural thinking, to algorithm through which students use each single case (each animal proposed in the game) not only as simple procedural description (each case as a particular problem) but also as a representative of all the possible series, connected through the construction of an algorithm; typical reasoning of construction adopted in the written Chinese language.

This kind of strategy is evident comparing videotapes with the data analysis; it does not appear analyzing strategies adopted by Italian students.

With regard to our research, there are other interesting aspects regarding the way to “read” the *box/matrix* and discuss it in its “solution”.

The most evident difference between Chinese and autochthonous argumentation is that Chinese students seem to use mainly a pragmatic way of reasoning. During the game it often happens that they try indeed to show the truthfulness of a particular assertion with a sketch or a particular “operation”. The Italian students instead used to justify the adopted strategy, a kind of “local reasoning”, with “theoretical” reference to

the scheme of the situation. The chosen “theoretical” references result to be more and more formally rigorous during the game.

From the analysis of the strategies adopted by the students (Italians and Chinese) in the resolution of the assignment, it is also possible to underline the ability of the Chinese children to read and therefore to interpret the *box/matrix* proposed in a holistic way, with a global vision. They show therefore attention to the particularity of each single case, each single card image presented in the game, reading the table, in a unitary vision. They underlined immediately, as first step of the game, what was important for the solution of the game, the essential elements of the situation where the data was meaningful for the problem.

Examples of question to Chinese students were:

... *We have one “non influence” animals that we can consider only at the end;*

... *We have animals that can be posed only in one part of the box.*

If the Italian children prefer and argued strategies based on attempts and errors, looking for first step, the single relationships among the various image cards (animals) in the game and working on the box for lines or columns and only after in parallel, through lines and columns; the Chinese student, maybe only because, as we just said, of the relationships that is possible to find between this kind of situation/game and some of the linguistic aspect of the Chinese written language, underlines a more uninhibited attitude, working immediately in parallel on lines and columns and reading so the box in an unitary way and justify their behavior with holistic procedures in argumentation and conjecturation.

Other interesting considerations can be driven from the videotaped classroom experience, in particular the interview to the two Chinese students. From this further qualitative analysis, evidently comes out how, in the two cultures (Italian and Chinese), the meaning of the term “To think for cases” is interpreted. Is it a behavior connected to the arithmetical thought, to attempts and errors? It is a scheme for augmenting a solution and conjecture different possible cases? In this sense the proposed activities could allow critical and more careful reflections on the possible correlation between Chinese language, entirely “abstract” and with an “algebraic nature” (in the mathematical meaning) with a complex syntax, Chinese thought and mathematical reasoning schemes (logical-argumentative problematic) adopted by students in class to solve a mathematical problem. In according in fact with idea, the hypothesis, that exists a strong correlation among the Chinese language, at least written language, and the mathematical thought (Spagnolo 2002); this correlation involves also the behavior of students in class when they solve a mathematical problem and to support Hok Wing and Bin (2002, 223-224) who sustain that the Chinese students furnish the tallest performances of the world in assignments that ask the application of mathematical abilities we could consider, as we said previously, this analyzed situation/problem as starting point for future more specific and deepest researches in this context. Particular attention in this sense will be turned, in the future developments of the research to the depended analysis of the *algebraic nature* of the written Chinese language and the correlation that it could have in the main study of the difficulties showed by the student (western and Chinese) of different grades in the phase of argumentation and

conjecturation in the passage from the Arithmetical thought to the Algebraic one, from “To think for cases” in the arithmetical acceptance to the final formalization; problems already well documented and discussed in literature when looking at Western research.

References

- Agli F., D’Amore B. (1998) *L’educazione matematica nella scuola dell’infanzia. Lo spazio, l’ordine, la misura*. Milano: Juvenilia (VIII ed.)
- Arzarello F., Bazzini L., Chiappini G. (1994) *L’Algebra come strumento di pensiero. Analisi teorica e considerazioni didattiche*. Pavia: Progetto Strategico CNR - TID, Quaderno n. 6.
- Bednzar N., Radford L., Janvier B., Lepage A. (1992) *Arithmetical and algebraic thinking in problem solving*. Durham, USA, University of New Hampshire: Proc. PME XVI, Vol.1, pp. 65-72.
- Brousseau G. (1983) *Les obstacles épistemologiques et les problèmes en Maths*. RDM, Grenoble: ed. la Pensée Sauvage, Vol.4.2
- Brousseau G. (1998) *Théorie des situations didactiques (didactique des mathématiques 1970-1990)*. Grenoble: ed. la Pensée Sauvage
- Barton W.D. (1996) *Ethnomathematics: Exploring Cultural Diversity in Mathematics*. Auckland: ResearchSpace@Auckland
- Cai J. (1999) *Understanding and representing the arithmetic averaging algorithm: an analysis and comparison of US and Chinese students’ responses*. int. j. math. educ. sci. technol., 2000, vol. 31, no. 6, 839–855
- Cai J., Nie B. (2007), *Problem solving in Chinese mathematics education: research and practice*. ZDM, Volume 39, Numbers 5-6.
- Canevaro P. (1983) *Nuestro patrimonio cultural y su enseñanza escolar*. Lima: Enseñanza de la historia.
- Clausse A. (1977) “Educazione”, *Enciclopedia del Novecento*, Vol II. Roma: Enciclopedia Treccani.
- Chemla K. (2001) *I “Nove capitoli sui procedimenti matematici”: la costituzione di un canone nella matematica*. Storia della Scienza: Cina, India, Americhe, Istituto della Enciclopedia Italiana fondata da Giovanni Treccani S.p.a.
- Chemla K. & Guo Shuchun (2004) *Les Neuf Chapitres*. Paris: Ed. Dunod
- Chemla k. (2007) *Matematica e cultura nella Cina antica*. (Bartocci. C., Odifreddi P., La matematica, i luoghi e i tempi, Einaudi, 2007)
- D’Ambrosio U. (2002) *Etnomatematica*. Bologna: Pitagora Editrice

- Di Paola B. (2004) *Some experimental observations about the passage from the arithmetical thought to the algebraic thought*. Podebrady, Czech Republic: <http://www.pedf.cuni.cz/kmdm/yerme/index.html>
- Gagatsis A. (2003) *A multicultural approach to understanding and learning mathematics*. Athens: Proceedings 3rd Mediterranean Conference On Mathematical Education, 3-5 January
- Garcia Hoz V., Guerriero A.B, Santo Di Nuovo, Zanniello G. (2000) *Dal fine agli obiettivi dell'educazione personalizzata*. Palermo: Ed. Palumbo.
- Gheverghese J. G. (1987) *Foundations of Eurocentrism in Mathematics*. Race and Class, XXVII..
- Granet M. (1988) *La pensée chinoise*. Paris: Editions Albin Michel
- Kosko B. (1995) *Il Fuzzy Pensiero*. Milano: Baldini&Casoldi, (Fuzzy thinking: the new Science of fuzzy logic, B. Kosko, 1993).
- Leu Yuh-chyn-Wu Chao-Jung (2002) *The origins of pupils' awareness of teachers' mathematics pedagogical values: confucianism an Buddhism*. Faculty of Education, University of Hong Kong, Pokfulam Road: ICMI Comparative Study Conference, 20-25 October.
- Needham J. (1981) *Scienza e Civiltà in Cina*. (Original title: *Science and Civilisation in China*, Cambrige University Press, 1959), I e II Vol., Einaudi.
- Nisbett R.E., Peng K., Choi I., Norenzayan A. (2001) *Culture and Systems of Thought*. Psychological R., 108, p.291
- Nisbett R.E (2003) *The Geography of Thought*. London: Nicholas Brealey Pbl. ltd.
- Piaget J. (1967) *Lo sviluppo mentale del bambino*. Torino: Einaudi
- OECD 2004, PISA (2003) *Learning for Tomorrow's World Executive Summary*
- OECD 2007, PISA (2006) *Science Competencies for Tomorrow's World Executive Summary*
- Sfard, A. (1991) *On the dual nature of mathematical conceptions: Reflections on processes and objects as different sides of the same coin*. Educational Studies in Mathematics, 22, 1,1-36.
- Sfard, A. & Linchevski, L. (1992) *Equations and inequalities. Processes without objects?*. Proceedings of PME XVI, Durham, 3, 136.
- Spagnolo F. (1996) *Insegnare le Matematiche nella scuola secondaria*, Italia: La Nuova Italia.
- Spagnolo F. (2002) *History and Ethno-Mathematics in the Interpretation of the process of learning/teaching*. University of Hong Kong: 13° ICMI Comparative Study Conference, pp.20-25.

- Spagnolo F., Ajello M., Xiaogui Z. (2005) *Cultural differences in scholastic and non-scholastic environments: reasoning patterns and logical-linguistic questions in European and Chinese cultures*. Copenhagen: Proceedings ICMI, <http://www.icme-10.dk/TG25>. http://math.unipa.it/~grim/21_project/21_malasya_2005
- Wang H. (1984) *Dalla Matematica alla Filosofia*. Tprino: Boringhieri
- Wing L. Hok, Bin W. (2002), *A comparaisn of strategies adopted by primary students in four cities of China in solving mathematical problems*. Terrasini (Palermo):Proceedings The Mathematics Education into the 21st Century Project, <http://math.unipa.it/~grim/21project.htm>.
- Yong I.L. (1994) *Jiu zhang suanshu* 九章算術 (*nine chapters on the mathematical art*): *An overview*. Archive for History of Exact Sciences, Volume 47, Number 1, Springer



Approaching mathematics through history and culture: A suggestion

Ioanna Georgiou

University of Warwick

Abstract

This paper describes a multi-cultural and historical approach to the teaching of mathematics, created through the views of researchers and authors who support approaching school mathematics through its history and the various applications of mathematics in different cultures around the world. A specific design within the context of this new approach was implemented as a pilot course at a private school and the participant students were attending year 5 (out of 6) of high school. The selection of the material was based upon the syllabus taught at Greek Public schools, called Core Mathematics (in contrast to Advanced Mathematics), and it was enriched with historical and cultural elements. The detailed description of the material used aims into highlighting the idea for approachable and meaningful mathematics, without diminishing the value of more traditional exercises. A brief literature review is found at the beginning of this paper, along with some information on the methodology. Emphasis is given on the presentation of the material used and how the original ideas were changing while the course was evolving.

Introduction

A wider world view and the need for multicultural education are the main triggers for this pilot mathematics course, as described here. Authors, researchers, but also educators around the world have sought historical elements as well as cultural elements in order to enrich the teaching of various lessons, and therefore students' general pedagogy. This quest and its findings –whatever these may be – does not only target into enriching the teaching of the various lessons, but also in discovering facts and elements that can encourage a deeper understanding of the sciences, how did they evolve, why did they flourish, how society influenced their development, how the results influenced the society itself, and many more questions regarding the history of sciences. For a more detailed description of the questions that the science historians may pose, one can refer to Gavroglou (2004).

Supporting the new approach

Ubitaran D'Ambrosio was the first to introduce the notion of Ethnomathematics. In his 1985 paper, he defined Ethnomathematics as the bridges that connect historians and anthropologists from one side and mathematicians from the other side, in order to identify the different kinds of mathematics that exists. This stance is not a widely

accepted one; A number of mathematicians and mathematics teachers cannot agree with the idea of the existence of different kinds of mathematics.

Zaslavsky (1973) discovered numerous interesting habits during her long research in African countries. These habits or perceptions were related to the mathematical tradition of the place, the methods they needed as well as strategy games children were playing at their leisure time. Shan and Bailey (1991) discuss the using of mathematics in our everyday lives and how mathematical textbooks may be biased towards specific groups of people. They believe that even racist behaviors can be challenged through the proper usage and teaching of mathematical notions.

The problems that emerge when such perceptions are expressed have been spotted and analyzed by Bishop (1991, 2001). In an article of his in *Issues of Mathematics Teaching* journal, titled “What values do you teach when you teach mathematics?” not all mathematics teachers would find his question valid. Do they teach any values at all to make it worth wondering what these values are? Derivatives are, in themselves, without any values and, therefore, the only value mathematics can carry is purely scientific. Nevertheless, there are educators who are convinced that mathematics is rich values that, although they may not be taught in the same immediate way as history, are such that mathematics conveys many more messages to the students than the teachers themselves would like to believe.

Joseph (1991) emphasizes the fact that mathematics is usually taught from a purely Euro-centric point of view, while contributions from other cultural groups, such as Egyptians, Babylonians, Arabs, Hindu, Chinese, are often omitted completely. This fact on its own focuses on the development of the sciences in Europe, as if the rest of the world never contributed, even though some non-European contributions are of central importance. Arabic numerals were created in India and the Arabic world and, if it was not for the Arab scientists, many scientific documents would have been lost forever during the medieval years. Cotton (2001) refers to another aspect of the options in the teaching of mathematics, regarding the ways in which mathematics can build or alter the understanding we have of our world. Mathematical tools provide a range of solutions that most people cannot understand.

This literature review can be extended further. On one hand the aim is to acknowledge the fact that Mathematical Education is a complicated issue and the approaches available are varied and rich in ways that move beyond traditional approaches. On the other hand, an aspect closely related to the first one is the recognition that the role of mathematics in education is not just to provide pupils with the scientific tools – which *are* important – but also to answer pupils’ questions, such as “where does the mathematics from?”, “why did it come about?”, “how”, “when” and so on, providing the students with a more understanding of mathematics as a science and as a human endeavor. This is how the role of a program for teaching mathematics through history and culture can be described in short.

Past researches on the role of the history of mathematics in the teaching of mathematics include teaching secondary school students and future maths teachers, but mainly the latter. Unfortunately, publications on using history of mathematics in secondary schools are sparse. Between 1994 and 1999, some students in England had the opportunity to select History of Mathematics as a unit towards the completion of their maths A level through the Nuffield Advanced Mathematics course (Neill, 1994). Lawrence (2007) has also been trialing historical elements for the secondary maths classroom and information, ideas and material from her project can be found online. Another example of research on approaching mathematics through history and culture in secondary schools is the doctoral dissertation by Pompeu (1992), which is nevertheless unpublished.

As far as using history of mathematics to train future teachers, Furinghetti (2007) describes a mathematical workshop for future teachers, where they studied history of mathematics, as well as historical recourses directly in order to gain a deeper understanding of the mathematical notions and where they came from and why did they survive up to today. Philippou and Christou (1998) noted that, after the completion of a three year program of teacher education using history of mathematics, the negative perceptions of the students towards mathematics were changing. An important factor influencing this change was probably the satisfaction students found when discovering the utility in mathematics.

The course described in this paper is based upon this very rationale: to disclose the utility in mathematics, where the maths came from, why it exists, and so on. The participating students were weak and had strongly negative attitudes towards mathematics. also In this paper, I focus on the description of the material and how decisions were made on changes during the year, since the methodology used was Action Research.

Action Research is the methodology used when the researcher is also the practitioner. When a problem has been located in a setting – in this case it is a school environment – actions are taken aimed at developing solutions to the problem. The practitioner brings in suggestions and modifies the actions according to the results or responses they receive (Gray, 2004). Since the researcher is also the teacher at this school setting, where a group of students has failed in the past or has very negative attitudes towards mathematics, Action Research was considered the most appropriate in terms of bringing suggestions for improving students' perceptions as well as achievement and understanding. Data collection methods included questionnaires, assessment material, interviews, observations, and journal keeping.

The participating students were aware of the fact that the course they attended was a pilot course and that they were not only allowed but also expected to express their opinions and sentiments regarding the material covered, what was most engrossing or

indifferent to them. The interaction between the teacher-researcher and her students was of great importance and it facilitated the receiving of feedback on what students considered to be relevant to them, helpful and important. This is how changes were decided, ending up with a proposition quite different from the original one, in terms of material and in ways of assessment. The material, the changes as well as the assessment methods suggested form the main part of this paper.

Detailed analysis of the original plan along with the changes

There is a rich bibliography to support such an endeavor and some indications of this are listed below. There are also many internet resources. Some of the ideas implemented in this program can also be found online at http://www2.warwick.ac.uk/fac/soc/wie/staff/staff_interests/hom/ioanna/, where students could find some information useful to them as well. The set of notes was prepared under the title “Mathematics through History and Culture”.

1. Dictionary of Mathematics (1989, 1998, 2003) Penguin Reference, Penguin Books
2. Eagle M.R. (1995) Exploring Mathematics Through History, Cambridge University Press Bicester Oxon
3. Lumpkin, B., Strong, D. (1995) Multicultural Science and Math Connections; Middle School Projects and Activities J. Weston Walch Publisher Portland, Maine
4. Katz, J.V. (1993) A history of Mathematics; an introduction Harper Collins College Publishers New York
5. Sesiano, Jacque (2000) Islamic Mathematics across Cultures; the history of the Non-Western Mathematics Selin, H. (ed.) Kluwer Academic Publishers Dordrecht Boston London
6. Wesley, A (1993) Multiculturalism in Mathematics, Science, and Technology: Readings and Activities Addison-Wesley Publishing Company
7. Wright, P. (1999) (ed.) The Maths and the Human Rights Resource Book; Bringing Human Rights into the secondary mathematics classroom Amnesty International UK
8. Historical Topics for the Mathematics Classroom (1969,1989) The National Council of teachers of Mathematics

The program was implemented throughout school year 2007-08 and it took place at a private English-speaking school in Cyprus. Participating students were 16-17 years old and attended year 5 out of 6 before graduating. The material was based upon the respective material suggested by the Core Mathematics Curriculum of the Ministry of Education of Cyprus. The chapters were originally related to those in the book distributed by the Ministry, but approached in a different way. The origins of each notion are examined up to a point: why this notion emerged, how it was used in the various cultures and how it is applied in our own (or the students' own) current culture.

After the end of each chapter there was a small “chapter-break” that presented issues from a greater “mathematical” area.

The first chapter introduced the students to the idea behind the preparation of this course. The students were informed that the material to be taught largely coincides with the public schools’ curriculum and that the approach was intended to be more helpful to them in terms of how approachable and how meaningful math can become through this course. The first activity was for the students to place some important historical facts on a number line. This action targeted the students acquiring a general perspective of history, an essential quality for a course heavily related to history. For example, many students were ignorant of how far back human civilization may go, and of how recent are the world wars, or even how we “measure” time.

The second chapter was a newspaper article written by a Mathematics Professor who aimed to demonstrate how mathematics is everywhere around us, without us realizing. The article is about Thanasis and his “adventures” from the time he wakes up, until he goes to his work. It was followed up by three questions open for discussion in class. These questions invited students to consider what the aim of the author was when writing this short story and if it was achieved, and to identify which mathematical fields were mentioned. The article was quite short but nevertheless rich; some students failed to see any purpose in it. The article can be found in the appendix.

Chapter three dealt with “Pythagoras, *his* theorem and the Pythagoreans”. The respective chapter in the public school book included the theorem and some exercises involving it. Since it is a theorem students have met at an earlier stage, the approach of the public school book was used as the introduction to the chapter; that included a reminder of the theorem along with a few standard exercises. The next part dealt with “Pythagoras’s theorem before Pythagoras”. Students learned that the Babylonians dealt with finding the relation between the side of a square and its diagonal, which is a special case of Pythagoras’s theorem, as it was named centuries after the Babylonians. They were also told that the Chinese used this theorem centuries before Pythagoras as well. This provides them with a sense of utility in math, since Babylonians and the Chinese used Pythagoras’s theorem, not for the sake of mathematics, but because they needed it as a tool. Williams, J. (1993) and Gerdes, P.(1994) provide justifications as to why this kind of knowledge is important for the structuring of perceptions of the students.

Pythagoras’s theorem was then examined as it existed in Ancient Greece, where it was proved, and it was no longer a mere tool. The Pythagoreans were also examined as a special society, which held specific beliefs and was heavily influenced by the strong perception that whole numbers may have special powers. These beliefs were diminished after the discovery of irrational numbers, with the use of Pythagoras’s theorem. The hypotenuse of an isosceles right triangle with the two sides equal to 1cm is $\sqrt{2}$ cm. After commenting on irrational numbers, the chapter closed with the introduction to students of a project that could include a biography, or Pythagoreans’ practices or any other

ideas the students might have. Since most students for this project chose the “secure” option of writing a biography of Pythagoras, subsequent projects were designed to be more open-ended so as to make students use their imagination and abilities.

Chapter 4 was the “break-chapter”. Students familiarized themselves with representing number using fingers. The discussion revolved around the fact that the current number system is not unique; other number systems were used in the past, and each system facilitated some needs. Students engaged during this lesson, and made comments regarding who might need this way of counting. What made the difference here was that the need for counting on fingers effectively was obvious; even though they probably wouldn’t need it themselves, they did acknowledge the need for the existence of these alternative systems.

Chapter 5 introduced sequences through Fibonacci sequence. Fibonacci’s problem of modelling a rabbit population initiated the discussion, which was extended through the application of Fibonacci sequence in nature and in art. Arithmetic and geometric sequences were then introduced through Malthus’s assumption on population growth. Malthus, tried to predict what the results of the geometric growth of the population and the arithmetic growth of food production would be. He predicted that world would run out of food relatively early. The question of what Malthus meant by the terms “arithmetic” and “geometric” as well as why he was wrong, dominated a discussion where a lot of students joined and expressed their opinion. This resulted in students understanding of the sequences and how mathematical tools can be used to describe real-world facts. They ended up being more receptive when the discussion on sequences became more theoretical. An idea that emerged from the discussion in the classroom was about radioactive particles and how significant their “half-life” is. If we began with 200 radio-active particles after an explosion (such as the one in Chernobyl) and half of them give their radio activity every a given amount of time, how long will it take for the area to get clear? This is a brilliant example of a situation that may be modelled using a geometric sequence with common ratio equal to 0.5. In this chapter, students were assessed using a “traditional” test, which included general questions as well as exercises.

The next “break-chapter” consisted of part of a transcribed university lecture on mathematics. This lecture was about mathematical problems yet to be solved and the solution (or the proof that no solution exists) will turn the mathematician into a millionaire. The accomplishments of such a reading are multiple. Students find out that even mathematicians have trouble in solving some problems, that not all problems have solutions and that the “production” of new mathematics is an endless procedure. What was revealed was that students thought that professors of mathematics could become millionaires just by their profession.

In chapter 7, efforts were made to deal with trigonometry, mainly through astronomy. The plan was to have logarithms next, as the invention that facilitated the use of

Approaching mathematics through history and culture

trigonometry rules due to the fact the logarithms required less labour. However, trigonometry appeared to be too difficult and uninteresting to the students, and the chapter was eventually abandoned, as were the logarithms. The project that was planned for trigonometry was replaced by the *Professionals' Project*, an idea that arose from an informal interview with students. The instructions for this project were as follows:

The aim of this project you are being assigned is to discover what kind of mathematics is used by different professionals.

You must choose any three different professionals and interview them about the kind of mathematics they use when they work. Try to get details as well as some examples that will enrich your project and make your descriptions more vivid.

You should write down the questions you asked and the answers you got as if you were writing for a journal. The minimum number of words is 500, but you should include all the information you manage to get, as there is no upper limit.

The results were very encouraging. Students could not find ready-made solutions online or anywhere else, so they had to use their imagination and communication skills to respond to this project. The professions chosen were quite varied and included an accountant, a house wife, a shoe sales person, an engineer, an architect, a computer programmer and more.

In the mean time, students were introduced to a board game taken from *SMILE* material (SMILE card number 0279), the HIGH JUMP GAME. The handout was double-sided and had the instructions on the one side and the board on the other. Students sat in pairs and small pieces of paper were used as counters. The winner of each pair would play against the winner of another pair until there was a winner. Student developed various strategies, some of them did not risk much – playing safe could not help them remain in the game for longer. Some more strategy games students learnt during this course were Tapatan from Kenya and Oware from Africa. Games helped them stay focused for longer and put sincere effort in devising an effective strategy.

The lessons then moved to Discussing Taxes. These lessons revolved around different kinds of taxes, how to calculate income tax, as well as calculating VAT using either the original value or the price paid at the till. The tables used to calculate these taxes can be seen below. Later came the calculation of VAT along with discounts. Students had to consider the question of which one should be calculated first and why. Does the decision make a real difference?

I. Georgiou

The following table can be used to calculate income tax, according to the laws in the Republic of Cyprus, in 2008.

Income	Difference	Percentage	Tax
€0 – €19 500	€	0%	
€19 501 – €28000	€	20%	
€28 001 – €36 300	€	25%	
€36 301 –	€	30%	
		Total Sum:	

The table that follows helps in calculating VAT, as well as original value and final price for products that are subject to a 15% VAT.

Value	VAT	Final Price
100	15	115
x	y	z

Students' attitudes towards this chapter were significantly more positive than any of the previous chapters. They felt that general knowledge on taxes as well as the ability to calculate them was something relevant to their lives, consequently useful to them. They demonstrated good behavior, asked a lot of questions and also did quite well at their test.

The original plan for chapter 10 was to deal with some more consumer problems but, after covering taxes, a substantial skill for a consumer, the lesson moved towards statistics. The occasion that brought about the discussion of statistics was the recent election in Cyprus. Students had many questions related to the procedures, the exit polls, the blank votes and so on; consequently statistics was proved to be an area of interest to the students and mathematically rich as well. Newspaper or magazine articles which used statistics, were brought into the classroom in order to initiate discussions, about the issues they addressed and about the statistics they used. Data collection methods as well as presenting data were worked upon. The assessment for this chapter involved a project once more: students had the chance to choose any subject area they were interested in, devise a questionnaire, distribute it to at least ten people and present

their results along with a discussion. This project became the final part of the course, although the original plan had included more.

The parts left out regarded visual illusions, geometry and perspective as well the reading of “Flatland”, by Abbot (1884) and discussions around mathematical novels. The idea about reading mathematical novels belongs to a Greek organization “Thales and Friends” who discusses approaching mathematics through fictional literature.

Conclusion

Opportunities to employ an annual program such as this are sparse. Such material is nevertheless an invaluable input that has been shown to help make mathematics meaningful and relevant to the students. The main inference made after the completion of this program and prior to any detailed analysis is that mathematics that is applicable in the students’ own culture, or which carries social concerns, receives positive reactions from the students. Historical elements did not seem to be of any special interest to these specific students. Another issue raised is that the project is a wonderful assessment method, even for mathematics, and that original ideas that involved the students’ personal experiences provided them with a great opportunity to demonstrate their understanding and skills.

References

- Abbot, (1884) *Flatland; A Romance of many dimensions*, Dover Publications
- Bishop, A.J. (1991) *Mathematical Enculturation: A Cultural Perspective on Mathematics Education*, Kluwer Academic Publishers
- Cotton, T. (2001) Mathematics Teaching in the Real World in Gates, P.(ed.) *Issues in teaching mathematics*, Routledge Falmer
- D’ Ambrosio, U. (1985) Ethnomathematics and its place in the history and pedagogy of mathematics, *Schools, Mathematics and Work*, Harris, M.(ed.) The Falmer Press
- Furinghetti, F. (2007) Teacher Education through the History of Mathematics, *Educational Studies of Mathematics* 66:131-143, Springer
- Gavroglou, K. (2004) The past of Sciences in the form of History, University of Crete Publications (in Greek)
- Gerdes, P.(1994) Reflections on Ethnomathematics, *For the Learning of Mathematics* 14(2) 19-22. FLM Publishing Association
- Gray, D. (2004) *Doing Research in the Real World*, Sage, London
- Joseph, G.G. (1991) *The Crest of the Peacock; Non- European Roots of Mathematics*, Penguin Books

- Lawrence, S. (2007, online recourse) <http://www.ncetm.org.uk/Default.aspx?page=13&module=res&mode=100&resid=3245> (accessed on 28/06/08)
- Neill, H., (ed.) (1994) *Nuffield Advanced Mathematics: History of Mathematics*, Harlow: Longman.
- Pompeu, G. (1992) Bringing Ethnomathematics in the Curriculum, Unpublished Doctoral Dissertation, University of Cambridge
- Shan, S.J., Bailey, P. (1991) *Classroom Mathematics for Equality and Justice*, Trentham Books
- SMILE, "The High Jump Game", Card number 0279. London: SMILE.
- Thales and Friends (website) <http://www.thalesandfriends.org/en/index.php> (accessed on 29/06/08)
- Williams, J. (1993) *Multicultural Mathematics; Teaching Mathematics from a Global Perspective*, Oxford University Press
- Zaslavsky, C. (1973) *Africa Counts; Number and Pattern in African Culture*, Lawrence Hills

Appendix

An ordinary morning...

By Tefkros Michaelides

PhD Mathematics, Math's Teacher, Writer, Translator

Newspaper TA NEA 02/03/05

Thanasi's radio- alarm clock rang at seven. Due to the digital technology, which is based on numerical analysis and the binomial system, the sound filled the room, as if a whole orchestra had gathered next to his pillow. He got up. His fridge and microwave oven, functioning with fuzzy logic, a branch of the multi-value symbolic logic – which also was in charge for the secure function of the ABS of his car – had provided him with a huge breakfast in ten minutes time. At 7:40, he was typing the 4-digit code for the house alarm (according to the probability theory the potential burglar had only 1 chance in 10 000 to break in) and left for work, feeling safe. He used the tube; what a miracle! Tunnels, channels, supply nets, a whole underground city, designed according to Euler's Graph Theory. He got inside, made himself comfortable, and opened his newspaper: "12% reduction of accidents, after applying the alcohol tests – 27% of the drivers had already conformed to the new strict regulations". 12%, 27%! How on earth did they find that? He turned to the Sports section: Konstantinou scores a goal by sending Archimedes' b-type semi-regular 32-hedron (the football that is) into the net. At 8:30 he was entering his office. He switched on his computer (which was filled with integrated network based on Boolean Algebra, which Thanasis didn't know, nor he wanted to find out about it) and logged on to the internet. RSA code, based upon prime

Approaching mathematics through history and culture

numbers, provided him with a secure connection on the web. He opened his mailbox. Message from Maria – the you-know-who. She’s a nice person he thought. Intelligent, polite, cheerful, smart, pretty. Her disadvantage was one and only; she was studying math. Couldn’t she be studying something else? Something closer to real-life? Something useful anyway! These were Thanasi’s thoughts when he saw the manager approaching, so he immediately signed out of his e-mail account...

CHAPTER 6:

Mathematics Education and Topics in Teaching Mathematics



Is it possible to communicate mathematical meaning? – Epistemological analysis of interactive meaning construction in the classroom

Heinz Steinbring

Universität Duisburg–Essen, Campus Essen

Abstract of the theoretical part

Mathematical concepts are not empirical things, but represent relations. "... there is an important gap between mathematical knowledge and knowledge in other sciences such as astronomy, physics, biology, or botany. We do not have any perceptive or instrumental access to mathematical objects, even the most elementary ... The only way of gaining access to them is using signs, words or symbols, expressions or drawings. But, at the same time, mathematical objects must not be confused with the used semiotic representations." (Duval, 2000, p.61). With regard to this epistemological position, mathematical knowledge is not simply a finished product. The (open) concept-relations make up mathematical knowledge, and these relations are constructed actively by the student in social processes of teaching and learning.

In the interaction, the children have to deal with the not directly palpable mathematical knowledge and with the hidden relations by means of exemplary, partly direct interpretations - and not by means of abstract descriptions, notations, and definitions. By means of epistemological analysis (cf. Steinbring, 2000a; 2000b) it is to be found out whether the exemplary description used in the documented statement aims at a generalizing knowledge construction or whether it is a statement in the frame of the old, familiar knowledge facts.

The particular epistemological character of mathematical knowledge consists in the concentration on *relations* which are neither openly visible nor directly palpable. (Duval, 2000). In order to develop these relations and to be able to operate with them, they have to be represented by signs, symbols, words, diagrams, and references to reference contexts (Steinbring, 2000c), learning environments, or experiment fields. Thereby, the scientific status of the mathematical knowledge does not depend on the choice or the abstractness of the means of representation; neither are there any universal means of illustration distinguished a priori which would automatically guarantee the epistemological quality of the mathematical knowledge. The development of mathematical knowledge always occurs - be it in the academic discipline or in classroom learning processes - in social contexts which can, however, differ concerning their objectives and particular constraints (Steinbring, 1998).

In the exemplary episodes, an essential epistemological attribute of mathematical knowledge appears: A situationally tied form of describing and constituting the relations of mathematical knowledge in the frame of the exemplary learning environment; using exemplary, independent descriptions and words, but with the intentions - identifiable in the analysis - of generalizing exemplary attributes of the situation to the invisible general mathematical relations. In this regard, substantial learning environments represent a productive base for the interactive acquisition of knowledge, on which knowledge about mathematical knowledge can be acquired through the interaction at the same time, i.e., in the interaction, a specific, partly situation-bound, social epistemology of mathematical knowledge constitutes itself - which is not given by an independent authority from the outside.

This particular social epistemology constitutes itself in the course of the according situation, for example during the treatment of a learning environment, and for this purpose, it needs situative, exemplary context conditions as well as words and relations already known and familiar for communication. In order to understand how relations in mathematical knowledge - which are not directly, empirically palpable - can actually be expressed and communicated in this way, a thorough epistemological analysis is required (Steinbring, 2000b). Such qualitative analyses of different situative epistemological interpretations of mathematical knowledge in interactive treatments of learning environments have different objectives and react upon the perspective of mathematical knowledge taken in the different chapters. So, feedback to the design and construction of learning environments, especially such modifications which make these environments become living systems, occur; furthermore, testing analyses of environments by teachers or students can increase the awareness concerning the complex (professional) application conditions as well as the classroom interaction with mathematical learning environments.

A main issue of the presentation will be to carefully analyse how young students try with their own means of communication (i.e. pointing, verbalizing, using own descriptions and characterizations, etc.) to overcome the problem of communicating invisible mathematical knowledge. The students in the episodes presented try to »point directly« to the knowledge in question, that means to use a specific »objectification« of mathematical relations and invisible structures in the sense of quasi »empirical« mathematical objects they can speak about and that they can use in communication for mediating their understanding and interpretation of a mathematical idea to other students.

References

- Duval, R. (2000). Basic Issues for Research in Mathematics Education. In: Nakahara, Tadao & Koyama, Matsataka (Eds.), *Proceedings of the 24th International Conference for the Psychology of Mathematics Education*, Hiroshima, Japan: Nishiki Print Co., Ltd., 2000, vol. I, 55 – 69.

- Steinbring, H. (1998). Epistemological constraints of mathematical knowledge in social learning settings. In A. Sierpiska & J. Kilpatrick (Eds.) *Mathematics Education as a Research Domain: A search for identity*. Kluwer Academic Publishers, Dordrecht, 513 - 526.
- Steinbring, H. (2000a). Mathematische Bedeutung als eine soziale Konstruktion – Grundzüge der epistemologisch orientierten mathematischen Interaktionsforschung. In: *Journal für Mathematik–Didaktik*, Jahrgang 21, Heft 1, S. 28 – 49.
- Steinbring, H. (2000b). Epistemologische und sozial-interaktive Bedingungen der Konstruktion mathematischer Wissensstrukturen (im Unterricht der Grundschule). (Abschlußbericht zu einem DFG–Projekt, 3 Bände). Dortmund: Universität Dortmund, April 2000.
- Steinbring, H. (2000c). Interaction Analysis of Mathematical Communication in Primary Teaching: The Epistemological Perspective. In: *Zentralblatt für Didaktik der Mathematik*, 5, 138 – 148.
- Steinbring, H. (2005). The Construction of New Mathematical Knowledge in Classroom Interaction – An Epistemological Perspective, Mathematics Education Library, vol. 38, Springer, Berlin, New York.
- Wittmann, E. Ch. (2000). Plenary Lecture at ICME-9, Japan, ESM.

Appendix

Transcripts of Teaching Episodes:

1. Episode »Matthi ›points at‹ mathematical relations«

The following short episode is taken from a 4th grade mathematics lesson; the students work on number walls of four levels. The problem is to find out in common interaction in which way the increase of a base stone by 10 changes the value of the top stone; furthermore the students are expected to develop a justification for the operative change.

Explanation: *When describing the position of the numbers on the number wall, the stones are numbered consecutively in the transcript from the bottom to the top and from the left to the right.*

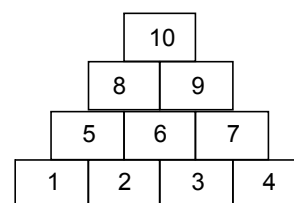

Before the beginning of the episode regarded here, the following three number walls with calculated numbers and also with magnetic chips can be found on the black board:

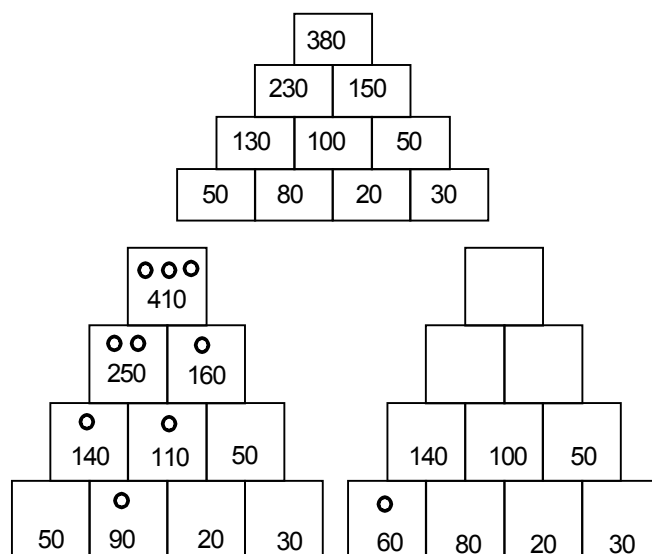

Fig. 1: Operative changes in four level number walls.

First of all the change in the second base stone (stone # 2) of 10, compared to the number wall above which is completely calculated, was examined. It was worked out that the top stone increases by 30; the stones in which an operative change occurred are marked with magnetic chips. In order to work on the question how the top stone increases when the left base stone (stone # 2) is raised by 10, the teacher has first changed the value of this stone to 60 and put a chip there; then a student has calculated the second row of the wall..

Now the student Matthi is called to the board; he wants to calculate the numbers of the third level but the teacher first asks for a justification.

- 196 T [whispers] ...Matthi!
- 197 Ma [goes to the black board] One hundred plus one hundred- [takes the chalk and wants to calculate the eighth stone] #
- 198 T # No. Matthi, would you stop, please? Did you notice anything? #

Epistemological analysis of interactive meaning construction in the classroom

199 Ma # Ohm, here [*points at the fifth stone*] is also ten more-
 [*points at the chip of the first stone*] #

200 T # [*whispers*] Ca you hand him a ten? #

201 Ma # [*C gives Ma a chip*] -because here is also ten more.
 [*puts one chip into the fifth stone of the right lower
 number wall*] Because here as well, because it's ten
 more here, [*points at the chip of the first stone*], here is
 ten more [*points at the fifth stone*] than there ten more.
 [*points at the upper number wall*] ...

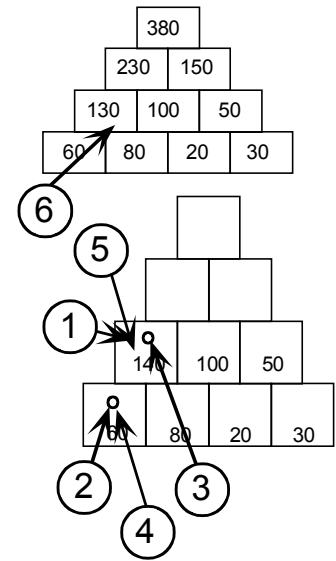

Here is the same then [*points at the sixth stone "100"*
 and then repeatedly alternately at the first and second
 stone of the right lower number wall], because one
 cannot this here plus that, if one that [*points at the fifth
 stone*].

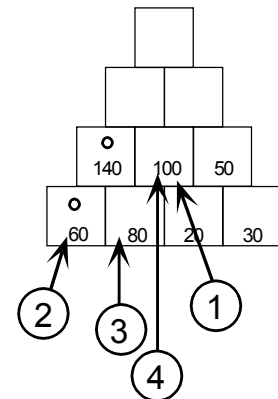

One does not get along with this here [*points
 alternately at the first and at the third stone*] then there
 [*points at the sixth stone and then at the first stone*], or
 so. That one that. [*points at the sixth stone*]......

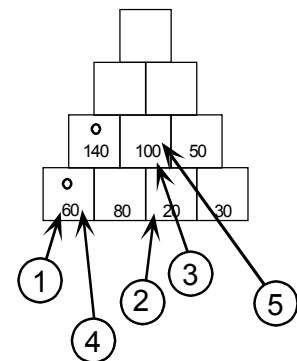

And here [points at the seventh stone] it's also the same, because that one is at the margin. [points at the first stone]

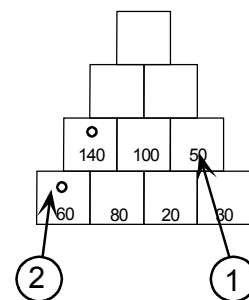

202 T Yes well, then we can go on calculating.

2. Episode »Kim uses an empty box in a number square like a number«

This short sequence of lessons has been conducted in a mixed 3rd and 4th grade class and deals with the topic of „crossing out number squares“. Crossing out number squares develop out of the addition of certain border numbers (in form of a table; cf. Fig. 1). Crossing out number squares have the following characteristics: In a (3·3) crossing out number square, one is allowed to chose (circle) any three numbers, so that there is one circled number in every row and every column. The sum of three numbers determined in this way is constant - independent on their choice (cf. Fig. 2). This number was called the »magic number«.

+	5	6	7
10	15	16	17
9	14	15	16
8	13	14	15

Fig. 1

15	16	17
14	15	16
13	14	15

Fig. 2

15	16	17
14	15	16
13	14	

Fig. 3

In the previous lessons the children have observed the constancy of the sum with given squares with the help of the so-called crossing algorithm; then procedures for producing crossing out number squares out of addition tables have been discussed and the connection between the crossing sum and the margin numbers has been examined.

In this lesson the children have to work on the following problem: How can one fill a gap in a crossing out number square with a missing number in such a way that the crossing out number square is re-established? (cf. Fig. 3). Different strategies are developed: The number 15 is mentioned because of its visible arithmetical pattern; then possible margin numbers are reconstructed (cf. Fig. 1). During the course of this lesson Kim makes another proposal; she wants to use the magic number (the constant sum of three circled numbers) for determining the missing number. With her own words – that other children have difficulty with to understand - she formulates her proposal.

59 T Well, and now? Kim.

60 K Eh, one could also do it like this, that one, one would do that now already. Then and then doesn't have the number yet. And then calculates together what's missing there. And then one can also calculate how, what belongs there.

61 T What do you mean by that?

62 K Ehm, that one now circles the thirteen, for example. And then would just cross out the fourteen. ...

63 T So you ha...

64 K [*incomprehensible*] ... fifteen. And then circles the fifteen..., no, yes, the fifteen. Circles the fourteen and the sixteen. And then circles the seventeen and crosses out the sixteen.

65 T Listen, Tim, eh, Kim! That's a really neat trick! We'll come to speak about that directly.

Later in the lesson, Kim is asked to concretize her proposal. First she uses the procedure to calculate the magic number by circling and crossing numbers in the square; she circles the following possible numbers and calculates the magic number with the task „13 + 15 + 17“ .

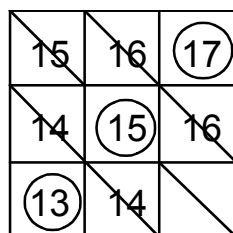

$$13 + 15 + 17 = 45$$

Then Kim repeats with her own words her proposal for calculating the missing number.

147 K And then one could already do it this way. One circles the fifteen [*points at the fifteen in the first line*] and this fifteen [*points at the fifteen in the second line*] and adds them. And then one still calculates how much there must be up to forty-five.

Kim gives the following explanation:

161 K First one calculates, one first calculates these numbers, that I have, which are there, what is their result. And then..., and then one calculates...

162 L # So. Now Kim explains how it goes on! Kim. #

- 163 # Yes. One first calculates the numbers there, that are there. # [Kim points with her open left hand globally at all numbers in the square]

15	16	17
14	15	16
13	14	

$$13 + 15 + 17 = 45$$

- 165 K These three, oh, yes, this, this and then afterwards one calculates fifteen [circles the fifteen in the second line], one takes this way. Cross out that, and that. And cross out that, and that. [crosses out numbers which are in the same line or column as the fifteen]

15	16	17
14	(15)	16
13	14	

$$13 + 15 + 17 = 45$$

Then one takes the fifteen. [circles the fifteen in the first line] Crosses the seventeen and the thirteen. [[crosses out the not yet crossed numbers which are in the same line or column as the fifteen]

(15)	16	17
14	(15)	16
13	14	

$$13 + 15 + 17 = 45$$

And then one circles this here, this here. [circles the empty field] And then one has to calculate fifteen and fifteen. This makes thirty; how much is left up to forty-five?

(15)	16	17
14	(15)	16
13	14	()

$$13 + 15 + 17 = 45$$

- 166 T Just write that down like this as an addition exercise! As you just did it, with a gap if you want to. [Kim wants to wipe out the exercise "13 + 15 + 17 = 45"] No, just leave that below!

On the teacher's inquiry, Kim writes down the following supplementary exercise below the addition exercise:

(15)	16	17
14	(15)	16
13	14	()

$$13 + 15 + 17 = 45$$

$$15 + 15 + _ = 45$$



Fuzziness, or probability in the process of learning? A general question illustrated by examples from teaching mathematics

Michael Gr. Voskoglou
Higher Technological Educational Institute
School of Technological Applications, Patra, Greece

Abstract

We introduce a fuzzy model to describe the process of learning a subject matter by students. Our model is presented in contrast to a probabilistic model, introduced in an earlier paper. A classroom experiment, that was performed in order to illustrate the use of the probabilistic model in practice, was repeated twice during the teaching process of the same cognitive object, with the same didactic material, the same conditions and the same method of teaching. The outputs of these two repetitions of the experiment are interpreted here in terms of the fuzzy model, so that the conclusions obtained from the application of the two models become easily comparable to each other.

The probabilistic model

The concept of learning is fundamental to the study of the human cognitive action. But while everyone knows in general what learning is, the understanding of the nature of this concept has proved to be complicated. This basically happens because it is very difficult for someone to understand the way in which the human mind works, and therefore to describe the mechanisms of the acquisition of knowledge from the individual.

There are very many theories and models developed from the psychologists and the education researchers for the description of the mechanisms of learning. Voss (1987) has developed an argument that learning is a specific case of the general class of transfer of knowledge and therefore any instance of learning involves the use of already existing knowledge. Thus learning consists of successive problem – solving activities, in which the input information is represented of existing knowledge, with the solution occurring when the input is appropriately interpreted.

The whole process involves the following steps: **Representation** of the stimulus input, which is relied upon the individual’s ability to use contents of his (or her) memory to find information, which will facilitate a solution development; **interpretation** of the input data, through which the new knowledge is obtained; **generalization** of the new knowledge to a variety of situations, and **categorization** of the generalized knowledge, so that the individual becomes able to relate the new information to his (or her) knowledge structures.

In an earlier paper (Voskoglou, 1997) we have constructed a probabilistic model – based on the above argument of Voss - for measuring the abilities of a student group in learning mathematics. More explicitly we obtained – in terms of the relevant frequencies - the probabilities $P(A)$, $P(B)$ and $P(C)$ for a student of the group to face successfully during the learning process of a new mathematical topic in the classroom the steps A of interpretation, B of generalization and C of categorization respectively, of the new information. Then the conditional probabilities $P(B/A)$, $P(C/B)$ and $P(C/A)$ give the probabilities for a student, after facing successfully a certain step, to do so and for the next step, or next steps of the learning process.

All the above were illustrated by a classroom experiment, presented also in Voskoglou (1997).

Fuzzy Sets

They are often situations in our everyday life in which definitions do not have clear boundaries, e.g. this happens when we speak about the "high mountains" or the "young people" of a country etc . The fuzzy sets theory was created in response to have a mathematical representation of such kind of situations.

Let U denote the universal set, then a fuzzy subset A of U , initiated by Zadeh (1965), is defined in terms of the membership function m_A which assigns to each element of U a real value from the interval $[0,1]$.

More specifically $A = \{(\chi, m_A(\chi)) : \chi \in U\}$, where $m_A : U \rightarrow [0,1]$.

The value $m_A(\chi)$, called the membership degree (or grade) of x in A , expresses the degree to which x verifies the characteristic property of A . Thus the nearer the value $m_A(\chi)$ to 1, the higher the membership degree of x in A . The methods of choosing the suitable membership function for each case are usually empiric, based on experiments made on a sample of the population that we study.

Obviously every classical (crisp) subset A of U may be considered as a fuzzy subset of U with $m_A(\chi)=1$, if $x \in U$ and $m_A(\chi)=0$, if $x \notin U$. Most of the concepts of classical sets are extended in terms of this definition for fuzzy sets. For example, if A and B are fuzzy subsets of U , then A is called a subset of B if $m_A(\chi) \leq m_B(\chi)$ for each χ in U , while the intersection $A \cap B$ is a fuzzy subset of U with membership function defined by $m_{A \cap B}(\chi) = \min \{ m_A(\chi), m_B(\chi) \}$, etc.

The application research currently taking place in the field of fuzzy sets covers almost all the sectors of the human activities, such as natural, life and social sciences, engineering, medicine, management and decision making, operational research, computer science and systems' analysis, etc (e.g. Herrera & Verdegay, 1997, Klir & Folger, 1988) .

For the complete understanding of this paper the reader is considered to be familiar with the basics of the fuzzy sets theory, for which we refer freely to Klir & Folger (1988).

The fuzzy model

Knowledge that students have about the various concepts is usually imperfect, characterized by a different degree of depth. From the teacher's point of view on the other hand,, there exists a vagueness about the degree of acquisition of the steps of learning – as they have been described in the previous section - from students. All these give the hint to introduce the fuzzy sets theory in order to achieve a mathematical representation of the process of learning a subject matter from students.

Let us consider a group of n students, $n \geq 2$, during the learning process in the classroom. We denote by A_i , $i=1,2,3$, the states of interpretation, generalization and categorization respectively, and by a, b, c, d , and e the linguistic labels of negligible, low, intermediate, high and complete acquisition respectively of each of the A_i 's.

Set $U=\{a,d,c,d,e\}$; then we are going to represent the A_i 's as fuzzy sets in U .

For this, if n_{ia} , n_{ib} , n_{ic} , n_{id} and n_{ie} denote the number of students that have achieved negligible, low, intermediate, high and complete acquisition of the state A_i respectively, $i=1,2,3$, we define the membership function m_{A_i} in terms of the frequencies, i.e. by

$m_{A_i}(x)=\frac{n_{ix}}{n}$, for each x in U . Thus we can write

$$A_i = \{(x, \frac{n_{ix}}{n}) : x \in U\}, i=1,2,3.$$

In order to represent all the possible profiles (overall states) of a student during the learning process, we shall consider a fuzzy relation, say R , in U^3 of the form

$$R = \{(s, m_R(s)) : s=(x,y,z) \in U^3\}$$

In order to determine properly the membership function m_R we give the following definition: A tuple $s=(x,y,z)$, with x,y,z in U , is said to be **well ordered** if x corresponds to a degree of acquisition equal or greater than y , and y corresponds to a degree of acquisition equal or greater than z ; e.g. the tuple (c,c,a) is well ordered, while the tuple (b,a,c) is not.

We define now the membership function m_R to be $m_R(s)=m_{A_1}(x)m_{A_2}(y)m_{A_3}(z)$, if s is a well ordered tuple, and 0 otherwise. In this way we block the possibility for student profiles like (b,a,c) to possess non zero membership degrees, which is absurd. In fact, if a student has not generalized at all, how can categorize the new generalized knowledge?

In order to simplify our notation we shall write m_s instead of $m_R(s)$. Then the possibility

r_s of the profile s is given by $r_s = \frac{m_s}{\max\{m_s\}}$, where $\max\{m_s\}$ denotes the maximal value

of m_s , for all s in U^3 .

Notice that during the learning process students may use reasoning that involves ampliative inferences whose content is beyond the available evidence and hence obtain conclusions not entailed in the given premises (e.g. such conclusions for mathematics

could be the illusion that $\sqrt{a+b} = \sqrt{a} + \sqrt{b}$, or $\log(a+b) = \log a + \log b$, etc) The appearance of conflict in the conclusions requires that the conclusions be appropriately adjusted so that the resulting generalization is free of conflict.

The value of the student group conflict during the learning process can be measured by the **strife function** on the ordered possibility distribution $r : r_1=1 \geq r_2 \geq \dots \geq r_n \geq r_{n+1}$ of the group defined by:

$$S(r) = \frac{1}{\log 2} \left[\sum_{i=1}^n (r_i - r_{i+1}) \log \frac{i}{\sum_{j=1}^i r_j} \right].$$

In general, the amount of information obtained by an action can be measured by the reduction of uncertainty that results from the action. Thus the **total possibilistic uncertainty** $T(r)$ of the student group during the process of learning can be used as a measure for its capacity for learning a subject matter. This is reinforced by Shackle (1961), who argues that human reasoning can be formalized more adequately by possibility theory rather, than by probability theory.

The value of $T(r)$ is measured by the sum of the strife $S(r)$ and **nonspecificity** $N(r)$ (Klir, 1995, p.28), defined by:

$$N(r) = \frac{1}{\log 2} \left[\sum_{i=2}^n (r_i - r_{i+1}) \log i \right].$$

In contrast to strife, which, as we have already seen above, expresses conflicts among the various sets of alternatives, nonspecificity is connected with the sizes (cardinalities) of relevant sets of alternatives.

The lower is the value of $T(r)$, the higher the acquisition of the new information from the corresponding student group.

Assume now that one wants to study the combined results of the behaviour of k different student groups, $k \geq 2$, during the learning process of the same subject matter. Then it becomes necessary to introduce the fuzzy variables $A_i(t)$, with $i=1,2,3$ and $t=1,2,\dots,k$, and determine the possibilities $r(s)$ of the profiles $s(t)$ through the

pseudofrequencies $f(s) = \sum_{t=1}^k m_s(t)$.

Namely $r(s) = \frac{f(s)}{\max\{f(s)\}}$, where $\max\{f(s)\}$ denotes the maximal pseudofrequency.

The possibilities $r(s)$ of all the profiles $s(t)$ measure the degree of evidence of the combined results of the k student groups.

Obviously the same method could be applied when one wants to study the behaviour of a student group during the learning process of k different cognitive objects, $k \geq 2$.

A classroom experiment for the learning process of mathematics

Mathematical activity is an original and natural element of the human cognition. It is of great importance therefore to find an effective way to describe the learning process of mathematics from students. This gave us the impulse to perform the following experiment, which is based on the fuzzy model for learning presented in the previous section.

The experiment took place at the higher Technological Educational Institute of Messolonghi in Greece, when I was teaching the definite integral to a group of 35 students of the School of Administration and Economics.

During my 3 hours lecture I used the method of rediscovery (Voskoglou, 1997) keeping in mind what Polya (1963) says about active learning: “For an effective learning the learner discovers alone the biggest possible, under the circumstances, part of the new information”.

Thus in my short introduction I presented the concept of the definite integral through the need of calculating an area under a curve, but I stated the fundamental theorem of the integral calculus – connecting the indefinite with the definite integral of a continuous in a closed interval function - without proof. Then I left students to work alone and I was inspecting their efforts and reactions, giving to them from time to time suitable hints, or instructions. My intension was to help them to understand the basic methods of calculating a definite integral in terms to the already known methods for the indefinite integral (state A_1 of the model).

I observed that 17,8 and 10 students achieved intermediate, high and complete interpretation of the new subject matter respectively. Therefore, in terms of our model, we have that $n_{ia}=n_{ib}=0$, $n_{ic}=17$, $n_{id}=8$ and $n_{ie}=10$. Thus the state of interpretation is represented as a fuzzy set in U as

$$A_1 = \{(a,0),(b,0),(c, \frac{17}{35}), (d, \frac{8}{35}), (e, \frac{10}{35})\}.$$

In the next step I gave to students for solution a number of exercises and simple problems involving calculations of improper integrals – as limits of definite integrals- and of the area under a curve, or among curves. My aim was to help them to generalize the new information to a variety of situations (state A_2 of the model). In the same way as above I found that

$$A_2 = \{(a, \frac{6}{35}), (b, \frac{6}{35}), (c, \frac{16}{35}), (d, \frac{7}{35}), (e,0)\}.$$

At the final step I gave to students for solution a number of composite problems involving applications of the definite integral to economics, such as calculation of the present value in cash flows, of the consumer’s and producer’s surplus resulting from the change of prices of a given good, of probability density functions, etc (Dowling, 1980, chapter 17). My intension was to help them to relate the new information to their existing knowledge structures (state A_3 of the model). In this case I found that

$$A_3 = \{(a, \frac{12}{35}), (b, \frac{10}{35}), (c, \frac{13}{35}), (d,0), (e,0)\}.$$

Observing the above representations of the A_i s as fuzzy sets in U , it can be seen that, the higher is i , the lower the membership degree of intermediate, high and complete acquisition of A_i in U . In other words, the higher is the state of the learning process, the lower the degree of acquisition of it from students, as it was normally expected.

It is a straightforward process now to calculate the membership degrees of all the possible profiles of the students (see column of $m_s(1)$ in Table 1). For example, if $s=(c,b,a)$, then

$$m_s = m_{A_1}(c) \cdot m_{A_2}(b) \cdot m_{A_3}(a) = \frac{17}{35} \cdot \frac{6}{35} \cdot \frac{12}{35} = \frac{1224}{42875} \approx 0,029.$$

It turns out that (c,c,c) is the profile with the maximal membership degree 0,082 and therefore the possibility of each s in U^3 is given by $r_s = \frac{m_s}{0,082}$. For example the possibility of (c,b,a) is $\frac{0,029}{0,082} \approx 0,353$, while the possibility of (c,c,c) is of course equal to 1.

Calculating the possibilities of the $5^3=125$ in total student group profiles (see column of $r_s(1)$ in Table 1) one finds that the ordered possibility distribution r of the student group is: $r_1=1, r_2=0,927, r_3=0,768, r_4=0,512, r_5=0,476, r_6=0,415, r_7=0,402, r_8=0,378, r_9=r_{10}=0,341, r_{11}=0,329, r_{12}=0,317, r_{13}=0,305, r_{14}=0,293, r_{15}=r_{16}=0,256, r_{17}=0,207, r_{18}=0,195, r_{19}=0,171, r_{20}=r_{21}=r_{22}=0,159, r_{23}=0,134, r_{24}=r_{25}=\dots=r_{125}=0$

Therefore the total possibilistic uncertainty of the group is $T(r)=S(r)+N(r)=0,565+2,405=2,97$ (the value of $T(r)$ was calculated with accuracy up to the third decimal point).

A few days later I gave the same lecture to a group of 30 students of another department of the School of Administration and Economics. I worked in the same way and this time I found that :

$$A_1 = \{(a,0), (b, \frac{6}{30}), (c, \frac{15}{30}), (d, \frac{9}{30}), (e,0)\},$$

$$A_2 = \{(a, \frac{6}{30}), (b, \frac{8}{30}), (c, \frac{16}{30}), (d, 0), (e,0)\}, \text{ and}$$

$$A_3 = \{(a, \frac{12}{30}), (b, \frac{9}{30}), (c, \frac{9}{30}), (d,0), (e,0)\}.$$

Then I calculated the possible profiles of the student group (see column of $m_s(2)$ in Table 1). It turns out that (c,c,a) is the profile possessing the maximal membership degree 0,107 and therefore the possibility of each s is given by $r_s = \frac{m_s}{0,107}$ (see column of $r_s(2)$ in Table 1).

Finally, in the same way as above, I found that $T(r)=S(r)+N(r)=0,452+1,87=2,322$.

Thus, since $2,322 < 2,97$, the second group had in general a better understanding of the new mathematical topic (definite integral) than the first one. This happened despite to the fact that the profile (c,c,c) with the maximal possibility of appearance in the first student group is a more satisfactory profile than the corresponding profile (c,c,a) of the second group.

Next, and in order to study the combined results of the behaviour of the two groups, we introduced the fuzzy variables $A_i(t)$, $i=1,2,3$ and $t=1,2$. Then the pseudo-frequency of each student profile s is given by $f(s)=m_s(1)+m_s(2)$ (see the corresponding column of Table 1). It turns out that (c,c,a) is the profile with the highest pseudofrequency 0,183 and therefore the possibility of each student profile is given by $r(s)=\frac{f(s)}{0,183}$. The possibilities of all profiles having nonzero pseudo-frequencies are given in the last column of Table 1

Table 1: Student profiles with non zero pseudofrequencies

A_1	A_2	A_3	$m_s(1)$	$r_s(1)$	$m_s(2)$	$r_s(2)$	$f(s)$	$r(s)$
b	b	b	0	0	0,016	0,150	0,016	0,087
b	b	a	0	0	0,021	0,196	0,021	0,115
b	a	a	0	0	0,016	0,150	0,016	0,087
c	c	c	0,082	1	0,080	0,748	0,162	0,885
c	c	a	0,076	0,927	0,107	1	0,183	1
c	c	b	0,063	0,768	0,008	0,075	0,071	0,388
c	a	a	0,028	0,341	0,040	0,374	0,068	0,372
c	b	a	0,028	0,341	0,053	0,495	0,081	0,443
c	b	b	0,024	0,293	0,040	0,374	0,064	0,350
d	d	a	0,016	0,495	0	0	0,016	0,087
d	d	b	0,013	0,159	0	0	0,013	0,074
d	d	c	0,021	0,256	0	0	0,021	0,115
d	a	a	0,013	0,159	0,024	0,224	0,037	0,202
d	b	a	0,013	0,159	0,032	0,299	0,045	0,246
d	b	b	0,011	0,134	0,024	0,224	0,035	0,191
d	c	a	0,031	0,378	0,064	0,598	0,095	0,519
d	c	b	0,026	0,317	0,048	0,449	0,074	0,404
d	c	c	0,034	0,415	0,048	0,449	0,082	0,448
e	a	a	0,017	0,207	0	0	0,017	0,093
e	b	b	0,014	0,171	0	0	0,014	0,077
e	c	a	0,039	0,476	0	0	0,039	0,213
e	c	b	0,033	0,402	0	0	0,033	0,180
e	c	c	0,042	0,512	0	0	0,042	0,230
e	d	a	0,025	0,305	0	0	0,025	0,137
e	d	b	0,021	0,256	0	0	0,021	0,115
e	d	c	0,027	0,329	0	0	0,027	0,148

Note: The outcomes of Table 1 are with accuracy up to the third decimal point.

Remark: The above experiment is actually a double repetition of the experiment presented in [6], during the teaching process of the same cognitive object (definite integral), with the same didactic material, the same conditions and the same method of teaching (rediscovery). Thus the conclusions obtained from the application of the two models - the probabilistic and the fuzzy one – become easily comparable to each other.

Conclusions

On comparing the probabilistic with the fuzzy model for learning, as well as the outcomes of the experiments, performed under the same conditions for the application of the two models in classroom, one is led to the following conclusions:

- Both models are based on the problem-solving argument of Voss for the process of learning.
- It becomes evident that, apart from mathematics, both models may be used – with the proper modifications each time – for the study of the learning process of any other subject matter by a student group.
- Both models provide useful quantitative information, which enables the instructor to get a concentrating view of the students' cognitive behaviour in terms of the new information presented. In this way he (or she) is helped efficiently to readapt the process, the rate and possibly the method of his (her) tuition, according to each case.
- The probabilistic model is easily understood and it is simple in its use for the teacher, who wants to apply it in practice. However it is self - restricted to give only quantitative information, i.e. probabilities of some indicators, which are connected to the abilities of a student group in learning a subject matter.
- On the contrary the fuzzy model, although a little bit difficult to be understood by the non expert and rather complicated in its use, it is not restricted only to quantitative information (possibilities, value of $T(r)$, etc), but it also gives a qualitative view of the behaviour of the learning group. In fact, through it one studies all the possible profiles of the learning students, and gets – in terms of the linguistic labels – an exact idea about the degree of acquisition of the successive steps of the learning process by them. In this sense the fuzzy model is a more useful tool for the education's researcher, than the probabilistic one.
- Another advantage of the fuzzy model is that it gives the possibility to study – through the calculation of the pseudo-frequencies of the several profiles – the combined results of behaviour of two, or more, student groups during the learning process of the same subject matter. Alternatively it gives also the possibility to study the combined results of behaviour of the same student group during the learning process of two, or more, different cognitive objects.

There is a lot of work in the area of student modelling in general and student diagnosis in particular. Our probabilistic and fuzzy models for the learning process give a new approach for the further study of this area. Analogous efforts, but with different methodologies, to use the fuzzy logic towards this direction and in mathematical education in general, have been attempted and by other researchers, e.g. see Perdikaris (1996), Espin & Oliveras (1997), Ma & Zhou (2000), Weon & Kim (2001), etc.

We must finally notice the importance of the use of stochastic methods (Markov chain models) for the same purposes, e.g. see Voskoglou & Perdikaris (1993), Voskoglou (2007), etc.

References

- Dowling E. T. (1980), *Mathematics for Economists*, Schaum's Outline Series, Mc Graw – Hill, New York.
- Espin E. A. & Oliveras C. M. L. (1997), Introduction to the use of fuzzy logic in the assesment of mathematics teachers', *Proceedings 1st Mediterranean Conf. on Maths Educ.* (A. Gagatsis, Ed.), 107-113, Cyprus
- Herrera F. & Verdegay G., L. (1997), Fuzzy Sets and Operations Research : Respectives, *Fuzzy Sets and Systems*, 90, 207-218.
- Klir G. J. & Folger T. A. (1988), *Fuzzy Sets, Uncertainty and Information*, Prentice Hall Int., London.
- Klir G. J. (1995), Principles of uncertainty: What are they? Why do we need them?, *Fuzzy Sets and Systems*, 15-31.
- Ma J. & Zhou D. (2000), Fuzzy Set Approach to the Assesment of Student-Centered Learning, *IEEE Transactions on Education*, 43(2), 237-241.
- Perdikaris S. (1996), A system framework for fuzzy sets in the van Hiele level theory of geometric reasoning, *Int. J. Math. Educ. Sci. Technol.*, 27(2), 273-278.
- Polya G. (1963), On learning, teaching and learning teaching, *Amer. Math. Monthly*, 70, 605-619.
- Shackle G. L. S. (1961), *Decision, Order and Time in Human Affairs*, Cambridge Univ. Press, Cambridge.
- Voskoglou M. G. & Perdikaris S. (1993), Measuring problem-solving skills, *Int. J. Math. Educ. Sci. Technol.*, 24(3), 443-447
- Voskoglou M. G. (1997), Some remarks on the use of rediscovery in the teaching of mathematics, *Proceedings 1st Mediteranean Conf. on Maths Educ.* (A. Gagatsis, Ed.), 124-128, Cyprus.
- Voskoglou M. G. (2007), A stochastic model fr the modelling process, In: *Mathematical Modelling (ICTMA 12) Education, Engineering and Economics* (C. Haines, P. Galbraith, W. Bloom and S. Khan, Eds), 149-157, Chichester, Horwood (U.K.)
- Voss, J. F. (1987), Learning and transfer in subject matter learning: A problem-solving model, *Int. J. Educ. Research*, 11, 607-622.
- Weon S. & Kim J. (2002), Learning Achievment Evaluation Strategy Using Fuzzy Membership Function, paper presented at the 31st ASEE/IEEE Frontiers in Education Conf., October 10-13, Reno, NV, USA
- Zadeh L. A. (1965), Fuzzy Sets, *Information and Control*, 8, 338-353.



How can mathematics reach children with learning difficulties?

Simoni Symeonidou

University of Cyprus

Abstract

This paper aims to discuss theoretical ideas, research evidence and practical ways related to the issue of making mathematics accessible to children with learning difficulties. Thus, an overview of the concept ‘learning difficulties’ is provided, followed by a discussion of the difficulties children face in mathematics and the teaching approaches that can facilitate learning. The paper focuses on children with difficulties in maths as well as children with difficulties in maths and reading. It aims to inform practitioners about their role in teaching maths in an inclusive education context where differentiation is the principal element of teaching.

Introduction

In a constantly changing educational scene, differentiating teaching becomes a crucial skill for all educators wishing to respond to the principles and values of inclusive education. Considering that schools are now expected to welcome individual differences and are encouraged to provide equal educational opportunities for all children, the targets set in all curriculum areas are under reconsideration. Increasingly, the *process* of individualised learning becomes more important than the group acquisition of a set amount of knowledge in a given time. Within this context, Didactics of Mathematics is an area that has much to offer in the common effort to maximise inclusion. It demonstrates a rich theoretical background and valuable research findings regarding the obstacles children face while learning specific mathematical concepts. What’s more, research in the Didactics of Mathematics has gone far in identifying how children with learning difficulties cope with mathematical concepts in relation to children who are not diagnosed as children with learning difficulties

Prior to engaging in the task of exploring how children with learning difficulties conceptualize mathematical concepts and how teaching can be enriched with meaningful approaches, it might be useful to explain in more detail what I mean by inclusion and inclusive classrooms. To begin with, inclusive education has gathered momentum at international level (UNESCO, 1994) as an approach that respects human rights and aims in providing equal education opportunities for all. According to Armstrong and Barton (1999: 215), ‘inclusive education is concerned with the human right for all children to attend their local school’. However, as inclusion is not an end in itself, rather it is a means to an end of establishing an inclusive society (Barton in Armstrong and Barton, 1999), it requires political, social and financial commitment in

restructuring the education system (i.e. internal structures, curriculum, in-service training) and the school (i.e. strategic planning for inclusion, pedagogical focus on differentiation, accessibility of buildings, reconsideration of the stakeholders' role – teachers, specialists, parents, children) in order to educate all children, regardless their gender, ethnicity, language, religion, disability and social class.

In principle, inclusion rejects all previous approaches in the education of children known as having 'special educational needs', such as segregation (educating children with special needs in the special school and children without special needs in the mainstream school) and integration (placing children with specific types of impairments in the mainstream school and expecting their adjustment in an environment that made minimum or no efforts to accommodate them). Inclusion is about an extension of the comprehensive ideal in education and thus, it is concerned less with children's supposed 'needs' and more with their rights (Thomas and Loxley, 2001). Following this line of thought, schools operating in an inclusive spirit are expected to demonstrate inclusive classrooms; classrooms that not only respect difference in principle, but are committed in employing pedagogical ways for raising each child's education to the best possible level.

In this paper, I will draw upon the definition and characteristics of children with learning difficulties. I will focus on the main research findings regarding children with learning difficulties on mathematics and children with difficulties both in reading and mathematics. Finally, I will make suggestions for approaches for differentiated teaching, targeting in facilitating learning for all in an inclusive maths classroom.

Understanding learning difficulties

Children with learning difficulties constitute a significant percentage of children attending mainstream school classes. Literature is rich in providing percentages indicating the prevalence of learning difficulties in different cultures, but focussing on percentage is not the terminus of this paper. As the appearance of children with learning difficulties does not differ from the appearance of their classmates without learning difficulties, the former are often marginalized and labelled as 'lazy students', 'indifferent for learning' or even 'not clever enough'. However, understanding this group of children is much more complicated than looking for percentages and adhering humiliating labels.

To begin with, children who experience difficulties in learning are characterised as children with learning difficulties (English term, employed in this paper) or children with learning disabilities (American term). As this is a long researched area, literature records numerous definitions, others developed for political reasons (legislation), others for academic reasons and others for purposes of assessment. As it is usually the case, different definitions grasp the substance of the phenomenon, while at the same time they emphasise different aspects of it. According to Lerner (1993), the common elements in most definitions of learning difficulties are: neurological dysfunction,

uneven growth pattern, difficulty in academic and learning tasks, discrepancy between achievement and potential, and exclusion of other causes. A quite comprehensive definition is the one developed by the National Joint Committee of Learning Difficulties (NJCLD) based in the United States of America.

Learning disabilities is a general term that refers to a heterogeneous group of disorders manifested by significant difficulties in the acquisition and use of listening, speaking, reading, writing, reasoning or mathematical abilities. These disorders are intrinsic to the individual, presumed to be due to central nervous system dysfunction, and may occur across the life span. Problems in self-regulatory behaviours, social perception, and social interaction may exist with learning disabilities but do not, by themselves, constitute a learning disability. Although learning disabilities may occur concomitantly with other disabilities (e.g., sensory impairment, mental retardation, serious emotional disturbance), or with extrinsic influences (such as cultural differences, insufficient or inappropriate instruction), they are not the result of those conditions or influences (NJCLD, 1998: 1).

The above definition clearly states that there can be six areas of difficulties in the acquisition and use of: listening, speaking, reading, writing, reasoning or mathematical abilities. According to Dockrell and McShane (1995) the difficulty children face can either be *specific*, as occurs when a child experiences problems with a particular task (such as reading, writing or mathematics) or it can be *general*, as occurs when learning is slower than normal across a range of tasks. They also argue that frequently, it can be problematic to distinguish between general or specific learning difficulties, as a specific learning difficulty may lead to other difficulties (e.g. a specific learning difficulty in reading may lead to difficulties with arithmetic as arithmetic requires reading abilities). Furthermore, children with general learning difficulties may show considerable competence in a specific area of cognitive functioning.

What is the profile of children with learning difficulties? Children with general learning difficulties may have poor memory, they tend to be slow in performing tasks (i.e. solving a problem) or in performing simple mental processes, they can easily be distracted, they are usually unable to generalize from one situation to another, they may face difficulties in identifying the problem and generating a problem-solving strategy, they may have difficulty with if-then relationships and they tend to be imprecise, impulsive and non-systematic in collecting information (Raban and Postlethwaite, 1992). This list can be enriched with the psychological condition of children with learning difficulties (i.e. poor self-esteem, learned helplessness, anxiety, frustration and a feeling of rejection). Turning the focus on specific difficulties such as difficulties in reading, writing and mathematics, literature is rich in recording long lists with children's characteristics. However, before outlining the profile of children with difficulties in reading, writing and mathematics, a clarification of important terms, such

as dyslexia and dyscalculia, needs to be made and their connection with learning difficulties needs to be drawn.

As I have already explained, learning difficulties are related to difficulties in listening, speaking, reading, writing, reasoning or mathematical abilities, they arise when a person lacks the necessary prerequisites for learning (perception, memory, language, thinking, problem solving) and they can be either specific or general. *Dyslexia* refers to a specific learning difficulty in reading, writing and spelling (Reid, 2008). It appears in all ages, races, and income levels. Dyslexia is described as a syndrome, which means that there is a pattern of signs and if several of them co-occur in the same individual, then the person can be characterised as dyslexic. The degree of dyslexia is dependent upon the number of signs possessed by a person. It is believed that children with dyslexia learn in a different way from other people and many of them are talented in other areas (i.e. art, music, and drama). Importantly, dyslexia has nothing to do with low intelligence as people who demonstrate dyslexic characteristics have usually typical IQ.

Dyscalculia refers to specific learning difficulties in mathematics (Chinn and Ashcroft, 1995). It is a contested term as researchers have not yet reached a consensus regarding its definition. According to Poustie (2000) children's condition may result from developmental or acquired dyscalculia; the former resulting from a specific learning difficulty in numeracy/mathematics – a condition that is present from birth – and the latter referring to all kinds of learning problems in mathematics caused by various factors, including developmental and acquired dyscalculia. Mazzocco (2007) approaches the issue using a different terminology. She explains that dyscalculia (which she also calls mathematical learning disability) is a biologically based and behaviourally defined condition. She distinguishes dyscalculia from 'mathematical difficulties', which are considered to be difficulties of environmental and not biological aetiology.

Apart from terminology and definition issues, dyscalculia becomes a contested term due to its unclear connection to dyslexia. Miles T. R. (1992) argues that questions about the relationship between dyslexia and dyscalculia are difficult to be answered as dyslexia is generally accepted as a syndrome, but it is not certain if this is the case for dyscalculia as well. Thus, Miles continues, it is misleading to ask how many dyslexics are also dyscalculic and how many dyscalculics are or are not dyslexic. Furthermore, there seems to be a consensus that most or all children with dyslexia have mathematical difficulties of some kind (i.e. problems with their immediate memory for 'number facts', difficulty in learning the tables, lose the place in adding up columns and numbers, difficulties over 'left' and 'right' which may affect their calculations), but these can be overcome in varying degrees, and in some cases they can become extremely successful mathematicians (Miles T.R., 1992).

Either we adopt the distinction between developmental and acquired dyscalculia or we distinguish between dyscalculia and mathematical difficulties, the real issue is that

How can mathematics reach children with learning difficulties?

children (with or without dyslexia) may face learning difficulties in mathematics that need to be identified. In what follows, there is a list of difficulties in reading, writing and mathematics that may be helpful to practitioners engaging in the process of identification.

Table 1: Reading difficulties, writing difficulties and difficulties in mathematics

Reading Difficulties	Writing Difficulties	Difficulties in Mathematics
<ul style="list-style-type: none"> • Poor reading ability (slow reading, no intonation, inability to understand what is read) • Additions (adds words to facilitate reading and/or make meaning) • Substitutions (reads the first letter/syllable and guesses the word or uses the context to make meaning) • Repetitions (reads same word twice) • Transpositions (i.e. <i>clod</i> for <i>cold</i>, <i>gril</i> for <i>girl</i>) • Omissions (skips a word) • Reversals (<i>dirb</i> for <i>bird</i>, <i>9</i> for <i>6</i>) • Difficulties in reading combinations of letters (i.e. th, ph, wh, ch, sh) • Difficulties in remembering the different sounds of the same combination of letters (i.e. 'gh' -> (f) or silent, e.g. enough, brought, 'ou' -> (u) or (ã u), e.g. soup, cloud) 	<ul style="list-style-type: none"> • Poor writing ability (untidy hand-writing, poor sentence structure, poor use of capitals, commas, full-stops) • Additions (<i>palay</i> for <i>play</i>) • Substitutions (<i>desk</i> for <i>office</i>) • Repetitions (<i>and and</i>) • Transpositions (<i>fier</i> for <i>fire</i>) • Omissions (<i>laer</i> for <i>later</i>) • Omissions of combinations of letters (<i>heory</i> for <i>theory</i>) • Reversals (<i>dolb</i> for <i>bold</i>) • Splits words (<i>be come</i> for <i>become</i>) • Unifies words (<i>andgo</i> for <i>and go</i>) 	<ul style="list-style-type: none"> • Difficulty arising from relative slowness in simple calculation • Multiplication tables - memorising difficulty • Difficulty in counting up • Difficulty in counting backwards • Difficulty in remembering carrying figures • Directional difficulties • Difficulties in subtraction (bridging the 10, directional difficulties and/or misunderstanding the direction of the principle of subtraction, difficulty in performing some methods of subtraction) • Multiplication and division • Difficulty due to copying down figures incorrectly • Arithmetical rules and mathematical formulae memorising difficulties <p style="text-align: right;"><i>British Dyslexia Association in Gagatsis, 1999.</i></p>

The above lists are not exhaustive as children may demonstrate additional characteristics to those mentioned here, or they may not face all the difficulties stated in each area.

In this paper, the focus is on children with learning difficulties in mathematics, including children with reading and writing difficulties (dyslexia). In order to reach children with learning difficulties, it is essential to be aware of the nature of mathematics and the potential areas of difficulty in the particular subject, issues that I now turn to explain.

In what ways can mathematics hinder children's learning?

Knowing the nature of mathematics is a prerequisite of conceptualizing the difficulties children face in this area. Chinn and Ashcroft (1995) argue that mathematics has an interrelating/sequential/reflective structure, and they go on to explain that it is a subject where one learns the parts; the parts build on each other to make a whole; knowing the whole enables one to reflect with more understanding on the parts, which in turn strengthen the whole. Knowing the whole also enables one to understand the sequences and interactions of the parts and the way they support each other so that the getting there clarifies the stages of the journey. Therefore, gaps in learning the different parts or difficulty in conceptualizing how the parts make a whole may result in poor achievement in mathematics. Furthermore, mathematics is communicated by using a special language expressed with symbols, graphic images and special vocabulary (Gagatsis, 1999). Consequently, mathematical texts demand special reading skills often acting as a barrier for children's learning.

Learning mathematics is highly associated with the individual's cognitive style. Pitta-Pantazi and Gagatsis (2001) report on research in psychology and mathematics education which points to the fact that individuals vary in their cognitive style. Although there can be many distinctions and terms referring to different learning styles, it might be useful to refer to two cognitive styles, known as the inchworms and the grasshoppers (Bath and Knox, 1984). In brief, inchworms and grasshoppers have differences in the way they analyse and identify a problem, in the methods they employ for solving the problem and in verifying the answer. For example, the inchworms focus on parts, attend to detail and they tend to separate, whereas the grasshoppers have a holistic approach, they form concepts and they put different parts together; the inchworms use a formula/recipe to solve a problem whereas the grasshoppers employ controlled exploration; the inchworms are unlikely to verify their answer and if they do, they use the same method, whereas the grasshoppers are more likely to verify and they will probably use alternate method.

There are many potential areas of difficulty in mathematics. Reviewing relevant literature, one can find different sets of difficulties proposed by researchers who focus on different aspects of learning and/or mathematics. For example, Butterworth and Reigosa (2007) refer to dyscalculia and they focus on information processing deficits in memory, language and space. However, commenting on relevant research evidence, they explain how complex it is to conceptualize how these areas contribute to difficulties in mathematics and how they interact. Chinn and Ashcroft (1995) list directional confusion, sequencing problems, visual perceptual difficulties, spatial awareness problems, problems in short term and long term memory, the language of mathematics difficulties in naming, word skills, cognitive style, conceptual ability, anxiety and self image. The British Dyslexia Association has also listed ten potential areas of difficulty in maths for children with dyslexia, shown in the table presented earlier. In this paper, I will focus on language and I will explain how it can be

associated to specific difficulties encountered by children struggling with several aspects of mathematics.

Although it is argued that the language and number circuits in the adult brain are distinct, and thus, the individual can be successful in language tests but fail in numeracy tests (Butterworth and Reigosa, 2007), research and practice suggest that language, in its broad sense, can be associated with difficulties in mathematics. Jordan (2007) argues that reading difficulties appear to aggravate rather than cause math difficulties, and he adds that although reading skill predicts math achievement, number sense is a stronger predictor. Having examined several studies comparing children with math difficulty only (MD only) to children with math difficulty and reading difficulty (MD/RD) or to children with reading difficulty only (RD only), Jordan (2007: 110) ended up with a list of the possible problematic skills in mathematics.

Table 2: Areas of difficulty in children with MD only, MD/RD, and RD only

Skill	MD only	MD/RD	RD only
Counting	+	+	–
Number knowledge	+	+	–
Rapid fact retrieval	+	+	–
Number naming	+	+	–
Problem solving	–	+	–
Reliance on fingers	+	+	–
Digit span	–	+	–
Mazes (spatial skill)	–	–	–
Word articulation speed	–	+	+

Note: + = deficiency, – = no deficiency

In the light of the compilation of results from several studies presented above, it becomes clear that children with math difficulty only, as well as children with math difficulty and reading difficulty, show similar functional profiles with respect to number (i.e. weak calculation fluency reflects basic deficits in counting procedures and number knowledge). Considering this relationship, it becomes important to consider how poor reading skills may be associated with difficulties in mathematics and, in particular, how they can interfere with understanding the text of a problem and the symbolic language of mathematics.

With regard to difficulties with the text, Miles, E. (1992) addresses the difficulties related to the vocabulary of technical terms, which are divided into two categories: (a) deceptively familiar terms used in a different sense (i.e. *makes* – mother makes a cake/two plus three makes five, *take away* – Chinese take away/five take away three, *odd* – something peculiar/odd numbers, *even* – keep your handwriting even/even numbers etc.) and (b) more lengthy terms which are totally new (i.e. *isosceles*, *vector*, *coefficient*, *simultaneous* etc.). Although these examples refer to the English language, there are equivalent examples in other languages as well. Gagatsis (1997) provides similar examples in Greek language (i.e. *aktina* – ray (of light)/radius (of a circle), *tokso*

– bow/arc, *kentro* – restaurant/centre (of a circle), *dinami* – power/force). Another problem, according to Miles, E. (1992), can be that the same operation may be signalled by a large number of everyday terms (i.e. ‘altogether’, ‘total’, ‘sum’, ‘plus’, ‘add’, ‘and’, must all be interpreted as ‘addition sum needed here’; ‘minus’, ‘difference’, ‘how much more’ must all be interpreted as ‘subtraction sum needed here’).

As far as the difficulties with the symbolic language of mathematics are concerned, Miles, E. (1992) notes that these can be related to the Arabic numerals, the algebraic symbols and mathematical symbols other than numerals. Some of the difficulties with Arabic numerals are: confusion between numbers of similar visual appearance (i.e. 6 and 9), changing the position of numbers (i.e. 342 and 423), difficulties in identifying small differences in the position of numbers in order to continue a series of numbers, understanding the symbolization of fractions considering that numbers in that case cannot be treated as whole numbers, difficulties over direction when operating a vertical addition or multiplication. These difficulties are related with difficulties in reading and writing, such as confusion of similar letters, reversals of the letters in a word and the fact that in order to read or right a person is taught to move from left to right and not to change directions as it is often the case in mathematics. The algebraic symbols can also be confusing as the child is required to associate letters with numbers and not letters with words, as it is the case in reading (i.e. Mr Smith has a number of cars C – C does not stand for cars but for the number of cars). Last but not least, mathematical symbols other than numerals are also a source of difficulty. Starting from the fundamental symbols +, −, X, :, a child needs to differentiate between the four and then make the connection between addition and multiplication, and subtraction and division. The difficulty arises as the two symbols of each pair look like each other. Another difficulty is the direction on the symbols > (greater than) and < (less than) and the identification of different sorts of brackets, such as (), { } and []. According to Gagatsis (1997), an additional difficulty could be that the same mathematical symbol often takes a completely different meaning in different contexts. For example, the symbol − is used for subtraction (3 − 2), for negative numbers (− 2), for fractions etc.

In what ways can we teach children in order to facilitate their understanding of mathematical concepts?

Nowadays, teachers are expected to differentiate their teaching approaches in order to reach all children attending mixed ability classes. In particular, teachers need to adopt an inclusive philosophy and demonstrate a good ability to include all children in the learning process by identifying individual differences and by differentiating curriculum, instruction and material accordingly. To make the connection with the previous section, children who face difficulties in mathematics and children whose difficulties in mathematics become more evident due to difficulties in reading should be identified and confronted by the teacher in a systematic and effective way. In what follows, I will explain how difficulties with the language of mathematics can be tackled and how the

concept of number can be approached in order to overcome difficulties associated with mathematics and language.

With regard to the vocabulary of mathematical texts, teachers need to be aware of the particularities of mathematics presented in the previous section and modify their teaching in such a way to prevent further difficulties or to aid children overcome any difficulties they may have. Raban and Postlethwaite (1992) argue that it is important to establish consistency from teacher to teacher in the language used to talk about maths and careful thinking on behalf of the teacher about the language s/he uses to discuss mathematical ideas is essential. Furthermore, Gagatsis (1997) suggests that it is pointless to force students learn new vocabulary if we do not intend to use it. It is recommended that students learn only a small number of new terms and symbols, and that the same terms and symbols are used throughout the maths textbook or handouts. It might be useful to encourage children create small cards, easy to store in their pencil case, where they can write down the basic terminology of each chapter/thematic area. They can also draw a figure that helps them associate the term with its meaning. This card can be used as a source of reference every time a child is not sure about the meaning of a term.

Linked to the difficulties arising from unfamiliar terminology are the difficulties of reading a maths problem. Arguably, children who have difficulties in reading any text, it is certain that they will have difficulties reading and understanding a maths problem. A simple response to this difficulty could be that the teacher encourages children to draw a picture related to the problem, help them pick the essentials of what is required and rewrite the question in their own words (Miles, E. 1992). Another matter that teachers should take into consideration when differentiating is the structure of the sentences comprising a problem. Children with reading difficulties may need rewording of some sentences. For example, the sentence 'The perimeter of a rectangular piece of paper is 4.8 cm' is tortuous and condensed as the key-word 'rectangular' is in the middle of the sentence and it can be easily missed by the child (Miles, E. 1992). A simpler version of this sentence could be 'A rectangular piece of paper has a perimeter of 4.8 cm'. In this sentence, information is presented in such a way that may aid children to decode, and perhaps draw, the necessary information in the order they find it while reading.

It has already been argued that children with difficulties in maths and children with difficulties both in reading and maths face difficulties in number knowledge (Jordan, 2007). As this is one of the basic areas of the maths chain, it might be useful to consider ways of making it accessible to all learners. Chinn and Ashcroft (1995) argue that although children may recognize small numbers, they have difficulties in large numbers. Recognition of larger numbers can be facilitated if the objects are arranged in a recognizable pattern and if the number can be seen as a combination of other numbers. Chinn and Ashcroft (1995: 34) suggest that children can be taught how to break down

or build up numbers and visualize them through patterns familiar to them from dice or dominoes.

Table 3: Breaking down and building up numbers

1	.	
2	∴	
3	∴	
4	∴	
5	∴	
6	∴	
7	∴	seen as 5 and 2
	∴	seen as 4 and 3 or 6 and 1
8	∴	seen as two 4s
	∴	seen as 5 and 3
	∴	seen as three 3s
9	∴	seen as 5 and 4 or 8 and 1

Ioannou and Symeou (2008) refer to another approach developed in Germany, known as the ‘Numerical House’. In the heart of this approach lies the belief that children who are encouraged to conceptualize numbers visually in a recognizable pattern can apply this knowledge to more advanced concepts, and thus overcome possible difficulties. The central concept of this method is the figure of a house in which numbers are represented in a particular way, as shown below:

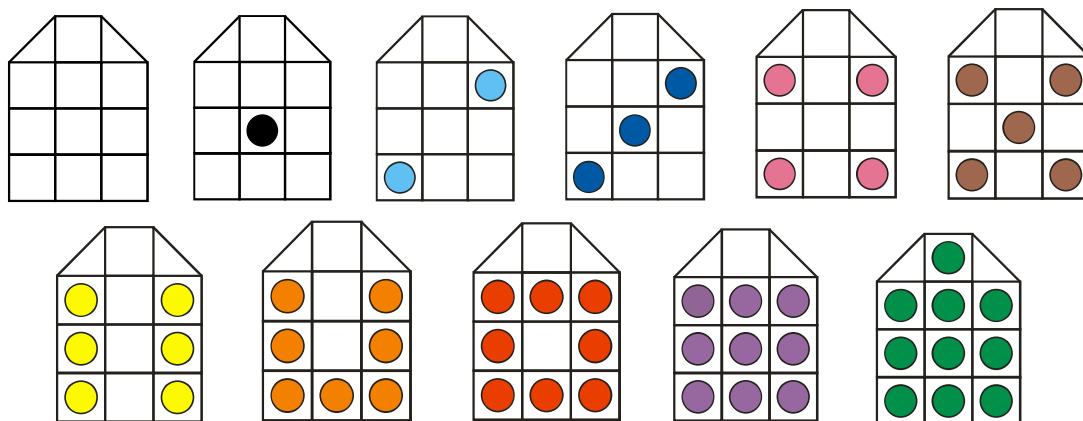

To help children establish the above figures in their memory, teachers develop games using normal and special dice (1-6 and 4-9 respectively), and the figure of the house either in wood or in laminate paper.

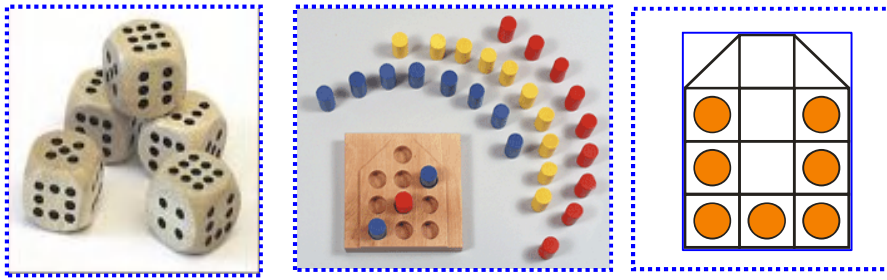

Apart from the conceptualization of numbers, this method is useful for understanding the tens, the place value, addition, subtraction, multiplication and division. Ioannou and Symeou (2008) report that they found this method extremely helpful and they have developed it further as a result of their teaching experience to a great number of children.

The approaches explained here are not exhaustive. Both researchers and practitioners may propose other methods that they find useful. However, it is important to take into consideration that teaching numeracy concepts entails serious consideration of the common difficulties children face and research evidence about ways to be overcome. One important tip is that teaching approaches need to be coherent as the concepts become more complex. Chinn and Ashcroft (1992: 102) list the principles of the scheme of presentation that should be used to encourage dyslexics visualize the numbers from 1 to 100:

- a. The scheme should help organization
- b. The scheme should be consistent over all the numbers – all the numbers should be present in logical positions
- c. The scheme should unify all aspects of numeracy
- d. From the scheme should grow naturally the required extra algorithms
- e. The scheme should be capable of supporting all future work

Another important tip is that children should be encouraged in ‘doing’ first and then in ‘naming’. Once the necessary foundations have been acquired by doing, then the abstract reasoning becomes less problematic (Miles T. R., 1992). The approaches presented here regarding numeracy rely on the above principles and it is up to the practitioners how far they can go with making numeracy teaching meaningful to children.

Conclusion

The question guiding this paper was ‘How can mathematics reach children with learning difficulties?’ and in my attempt to initiate a discussion, I have tried to outline the range of learning difficulties, the difficulties children may face in mathematics and some possible approaches that can facilitate their understanding of mathematical concepts. As mathematics is a huge area, I focussed on children with difficulties in maths only and children with difficulties in reading and maths. It becomes clear that

practitioners have a lot to learn from research in this area and that they have alternative ways of approaching maths in order to respond to mixed ability classes. Their guiding principle should be how to differentiate teaching in order to reach all children. In other words, practitioners are expected to focus on how to promote inclusive education through maths on the one hand, and on how to make maths accessible to all learners, on the other. This is not an easy task, but it is definitely possible.

References

- Armstrong, F. and Barton L. (1999) Is there anyone there concerned with human rights? Cross-cultural connections, disability and the struggle for change in England. In F. Armstrong and L. Barton (Eds) *Disability, Human Rights and Education. Cross-Cultural Perspectives*. Buckingham: Open University Press.
- Bath, J. B. and Knox, D. E. (1984) Two styles of performing mathematics. In: J. B. Bath, S. Chinn and D. E. Knox (Eds) *Dyslexia: Research and its Application to the Adolescent*. East Aurora, NE: Slosson.
- Butterworth, B. and Reigosa, V. (2007) Information Processing Deficits in Dyscalculia, in: D. Berch and M. Mazzocco (Eds) *Why is Math so Hard for Some Children?* Baltimore: Paul H. Brookes Publishing Co.
- Chinn, S. and Ashcroft, R. (1992) The use of patterns, in: T. R. Miles and E. Miles (Eds) *Dyslexia and Mathematics*. London: Routledge.
- Chinn, S. and Ashcroft, R. (1995) *Mathematics for Dyslexics. A Teaching Handbook*. London: Whurr Publishers Co.
- Dockrell, J. and McShane, J. (1995) *Children's Learning Difficulties. A Cognitive Approach*. Oxford: Blackwell.
- Gagatsis, A. (1997) *Didactics of Mathematics and Dyslexia*. Nicosia: Author's Publication.
- Gagatsis, A. (1999) Communicative interaction situations between children with symptoms of dyslexia constructing geometrical features, *Early Child Development and Care*, (151): 29-40.
- Ioannou, B. and Symeou, B. (2008) *The Numerical House*. Paper presented at Cyprus Association for Inclusive Education Seminar Series. Nicosia: University of Cyprus.
- Jordan, N. (2007) Do words count? Connections between mathematics and reading difficulties, in: D. Berch and M. Mazzocco (Eds) *Why is Math so Hard for Some Children?* Baltimore: Paul H. Brookes Publishing Co.
- Lerner, J. (1993) *Learning Disabilities. Theories, Diagnosis and Teaching Strategies*. Boston: Houghton Mifflin Company.

- Mazzocco, M. (2007) Defining and differentiating mathematical learning disabilities and difficulties, in: D. Berch and M. Mazzocco (Eds) *Why is Math so Hard for Some Children?* Baltimore: Paul H. Brookes Publishing Co.
- Miles, E. (1992) Reading and Writing in Mathematics, in: T. R. Miles and E. Miles (Eds) *Dyslexia and Mathematics*. London: Routledge.
- Miles, T. R. (1992) Some theoretical considerations, in: T. R. Miles and E. Miles (Eds) *Dyslexia and Mathematics*. London: Routledge.
- National Joint Committee on Learning Disabilities. (1998). Operationalizing the NJCLD definition of learning disabilities for ongoing assessment in schools. *Asha*, 40: III - 258a-g, (Suppl. 18).
- Pitta-Pantazi, D. and Gagatsis, A. (2001) Exploring a High Achiever's and a Low Achiever's Strategies and Images in Early Number Work, *Early Child Development and Care*, (166): 63-79.
- Poustie, J. (2000) *Mathematics Solutions. An Introduction to Dyscalculia – Part A*. Taunton: Next Generation.
- Raban, B. and Postlethwaite, K. (1992) *Classroom Responses to Learning Difficulties*. London: Routledge.
- Reid, G. (2008) *Dyslexia: A Practitioner's Handbook (4th edition)*. Hoboken: John Wiley & Sons Inc.
- Thomas, G. and Loxley, A. (2001) *Deconstructing Special Education and Constructing Inclusion*. Buckingham: Open University Press.
- UNESCO (1994) *The Salamanca Statement and Framework for Action on Special Needs Education. World Conference on Special Needs Education: Access and Equality*. New York: UNESCO.



University of the Aegean

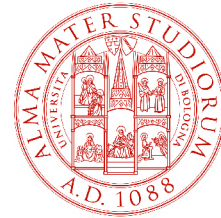

ALMA MATER STUDIORUM
UNIVERSITÀ DI BOLOGNA

University of Bologna



University of Cyprus, School of Social Sciences and Sciences of Education



University of Palermo



ASP Pedagogical High School, Locarno

In cooperation with: Cyprus Mathematical Society

Medium Size Research Program of the University of Cyprus Med19: "The functioning of representations in mathematics education with respect to the shift from elementary to secondary education"

RESEARCH IN MATHEMATICS EDUCATION