

# **RADIO RESOURCE MANAGEMENT FOR EFFICIENT MULTICAST SERVICE PROVISION IN 3<sup>RD</sup> GENERATION MOBILE CELLULAR NETWORKS**

Christophoros Christophorou

University of Cyprus, 2011

As currently specified by the 3rd Generation Partnership Project (3GPP) standards body for Universal Mobile Telecommunications System (UMTS), Multimedia Broadcast Multicast Service (MBMS) bearer services can be provided within a cell either by Point-to-Point (P-t-P) or Point-to-Multipoint (P-t-M) transmission mode, but not both at the same time. If a P-t-P transmission mode is selected, one Dedicated Channel (DCH) is established for each MBMS user within the cell. If a P-t-M transmission mode is selected, one Forward Access Channel (FACH) is established with fixed and adequate power to cover the whole cell's area, and shared by all the MBMS users within it. The decision of which transmission mode is to be adopted is made by the Radio Network Controller (RNC) based on a radio resource efficiency criterion.

Adopting the current 3GPP specified standards to provide MBMS services, can be very inefficient, e.g., more than 30% of the Node-B's total power has to be allocated to a single 64 Kbps MBMS service, if full cell coverage is needed. This can make MBMS services too expensive, since the overall UMTS network downlink capacity is limited by the Node-B's power source.

Motivated by the aforementioned, the general objective of this Ph.D. dissertation is to investigate and propose efficient, scalable and effective Radio Resource Management (RRM) algorithms that will facilitate efficient multicast service provisioning within the radio access

part of the UMTS networks where the radio resources are limited. In particular, we analyse the new features introduced with MBMS, identify factors that can influence the overall network capacity and performance during the MBMS service provisioning, formulate the problems, and propose new MBMS handover control and MBMS service provision solutions. Our proposed solutions dynamically control parameters such as transmit power, channel allocation, cell mode selection, and handover criteria, facilitating decisions targeting increased network capacity and overall system performance (and thus lower service costs), as well as acceptably good Quality of Service (QoS) for the MBMS users, during the MBMS service provisioning.

More specifically, during our research on MBMS handover control, we analyse the new mobility issues raised with MBMS and identify the new types of handovers introduced, that is handovers between P-t-P (DCH) and P-t-M (FACH) transmission mode cells. These new types of handovers impose new challenges (in term of network capacity, system performance and QoS) in the MBMS handover procedure that cannot be efficiently addressed by the current 3GPP specified handover control solution. A vital aspect for achieving efficient MBMS handovers' execution lies in the consideration of the FACH capacity benefits and its bounded coverage range characteristic, a feature not considered by the current 3GPP specified handover control approach or any of the other related approaches in the open literature. Thus, we proposed a new handover control approach, which considers the new features introduced with FACH in the handover triggering decision, to efficiently address the aforementioned challenges. Our proposed approach, in comparison with the current 3GPP specified one, achieves significant transmission power (capacity) savings, reduced inter-cell interference, downlink channel quality improvement, as well as QoS degradation avoidance during the handover (seamless handovers).

During our research on the MBMS service provisioning, we motivated the need for a new MBMS service provision approach, which allows both P-t-P and P-t-M transmissions to co-exist within the same cell and dynamically adapt during the session (referred as the "Dual Transmission mode cell" approach). Our proposed "Dual Transmission mode cell" approach

is evaluated and compared with other related approaches such as the “UE Counting”, “Power Counting”, “Rate Splitting”, and “FACH with Power Control”. The results demonstrated considerable gains outperforming all the other related approaches in terms of network capacity and link performance efficiency.

Furthermore, a new context reporting request process is proposed and integrated in our proposed “Dual Transmission mode cell” solution, which manages to also outperform all the other related approaches in terms of terminal’s battery consumption and uplink noise rise during context reporting. Also it significantly reduced the number of reports required to be received by the algorithm for a decision to be made. This results in less processing effort in the RNC and faster decision making. Moreover, the possibility for uplink congestion is also reduced (especially in cases where a great number of MBMS users are present in the cell and all attempt to report at the same time). Thus, even in situations where a large number of MBMS users are present in the cell, scalability and improved system performance are achieved.

**RADIO RESOURCE MANAGEMENT FOR EFFICIENT  
MULTICAST SERVICE PROVISION IN 3<sup>RD</sup> GENERATION  
MOBILE CELLULAR NETWORKS**

Christophoros Christophorou

A Dissertation

Submitted in Partial Fulfillment of the

Requirements for the Degree of

Doctor of Philosophy

at the

University of Cyprus

Recommended for Acceptance

by the Department of Computer Science

April, 2011

© Copyright by

Christophoros Christophorou

All Rights Reserved

2011

# APPROVAL PAGE

Doctor of Philosophy Dissertation

## RADIO RESOURCE MANAGEMENT FOR EFFICIENT MULTICAST SERVICE PROVISION IN 3<sup>RD</sup> GENERATION MOBILE CELLULAR NETWORKS

Presented by

Christophoros Christophorou

Research Supervisor

**ΠΡΟΣΩΠΙΚΑ  
ΔΕΔΟΜΕΝΑ**

Andreas Pitsillides

Committee Member

**ΠΡΟΣΩΠΙΚΑ  
ΔΕΔΟΜΕΝΑ**

Constantinos Pattichis

Committee Member

**ΠΡΟΣΩΠΙΚΑ  
ΔΕΔΟΜΕΝΑ**

Vasos Vassiliou

Committee Member

**ΠΡΟΣΩΠΙΚΑ  
ΔΕΔΟΜΕΝΑ**

Americo Correia

Committee Member

**ΠΡΟΣΩΠΙΚΑ  
ΔΕΔΟΜΕΝΑ**

Niovi Pavlidou

University of Cyprus

April, 2011

## **ACKNOWLEDGEMENTS**

Firstly, I would like to express my sincere appreciation to my thesis supervisor, Professor Andreas Pitsillides. I am very grateful for his continuous and inspiring guidance during my studies at the University of Cyprus. His valuable comments, suggestions and continuous encouragement were key to the successful completion of this thesis.

I am also grateful to my colleagues, Dr. Josephine Antoniou, Dr. Marios Lestas, Dr. Yiannos Mylonas, Dr. Vasos Vassiliou, Ph.D. candidate Panayiotis Andreou and Mr. Marinos Stylianou, for their help and support in overcoming technical issues and for various helpful discussions.

Also, I would like to thank my good friends who have supported me with their friendship and encouragement all these years of my studies, which led to the completion of my Ph.D. dissertation.

Last, but certainly not least, with my love and gratitude, I want to dedicate this Ph.D. dissertation to my father and mother who have generously and unconditionally supported me throughout my studies.

# TABLE OF CONTENTS

<b>Chapter 1 Introduction.....</b>	<b>1</b>
1.1 Motivation and Ph.D. Thesis objectives .....	3
1.2 Work accomplished and Contributions.....	4
1.2.1 Part 1 of Research: MBMS Handover Control.....	4
1.2.2 Part 2 of Research: Efficient MBMS Service provision in UTRAN...	6
1.3 Publications.....	9
1.4 Thesis Overview .....	13
<b>Chapter 2 Background Knowledge .....</b>	<b>15</b>
2.1 Radio Communication Fundamentals.....	15
2.2 Cellular Networks .....	18
2.3 Code Division Multiple Access (CDMA).....	21
2.3.1 Synchronous CDMA .....	23
2.3.2 Asynchronous CDMA .....	27
2.3.3 Spread-spectrum characteristics of CDMA .....	28
2.4 Universal Mobile Telecommunications System (UMTS).....	30
2.4.1 UMTS network architecture .....	30
2.4.2 Wideband Code Division Multiple Access (WCDMA) .....	33
2.5 Radio Resource Management .....	36
2.5.1 Handover Control .....	36
2.5.2 Power Control.....	40
2.5.3 Congestion control.....	43
2.6 Multicasting in UMTS Networks.....	44
2.6.1 Multicasting in UMTS Networks prior to MBMS .....	45
2.6.2 Multimedia Broadcast Multicast Service (MBMS).....	49
2.6.3 MBMS system architecture .....	51



2.6.4	MBMS Distribution Tree Construction .....	52
2.6.5	Characteristics of FACH and DCH channels .....	56
2.6.6	MBMS Counting Mechanism.....	56
<b>Chapter 3 MBMS Handover Control.....</b>		<b>60</b>
3.1	Introduction.....	60
3.2	Related Work .....	62
3.3	Motivation for a new MBMS Handover control approach .....	65
3.4	Main challenges of the proposed design .....	70
3.5	Problem Formulation .....	71
3.6	Proposed MBMS Handover control approach.....	75
3.6.1	Preliminaries.....	77
3.6.2	Description of parameters and thresholds used .....	79
3.6.3	Description of proposed MBMS Handover control approach .....	90
3.6.4	Processing - Memory requirements and Signalling Overhead .....	103
3.7	Performance Evaluation.....	109
3.7.1	Scenarios Description .....	109
3.7.2	Analysis of Results .....	115
3.8	Concluding Remarks.....	128
<b>Chapter 4 Efficient MBMS Service Provision in UTRAN .....</b>		<b>131</b>
4.1	Introduction.....	131
4.2	Related work .....	133
4.3	Dual Transmission mode cell concept .....	138
4.4	Motivation for “Dual Transmission mode cell” approach .....	139
4.5	Main challenges of the proposed design .....	143
4.6	Problem formulation .....	144
4.7	Proposed Radio Resource Allocation Algorithm.....	147
4.7.1	Description of the algorithm.....	148
4.7.2	Proposed Context Reporting Request process .....	172

4.7.3	Joining or Leaving the MBMS Service .....	180
4.7.4	Mobility Considerations: Intra- and Inter- cell handovers.....	181
4.7.5	Processing - Memory requirements and Signalling Overhead .....	193
4.8	Performance Evaluation.....	201
4.8.1	Scenarios Description.....	201
4.8.2	Analysis of Results .....	207
4.9	Concluding Remarks.....	236
<b>Chapter 5 Conclusions and Future Work.....</b>		<b>238</b>
5.1	Main Findings and contributions .....	239
5.2	Future work.....	245
<b>Bibliography .....</b>		<b>250</b>
<b>APPENDIX A: WCDMA RADIO CHANNELS.....</b>		<b>257</b>
<b>APPENDIX B: MBMS SPECIFIC WCDMA LOGICAL CHANNELS.....</b>		<b>262</b>
<b>APPENDIX C: ENHANCED MBMS SIMULATOR FOR ADVANCED RRM's.....</b>		<b>266</b>

## LIST OF TABLES

Table 1 Simulation Parameters used – Motivation for a new MBMS Handover control approach.....	66
Table 2 Capacity gain achieved when the PP parameter is considered .....	100
Table 3 MBMS Handover Control – Scenarios selected .....	110
Table 4 MBMS Handover Control Scenarios - Simulation Parameters used .....	111
Table 5 MBMS Handover Control - Scenario 1 and 2: Summary of the Results Presented .....	121
Table 6 MBMS Handover Control – Scenario 3: QoS experienced .....	123
Table 7 Simulation Parameters – Motivation for “Dual Transmission mode cell” scenario .....	139
Table 8 Aggregated Processing Effort Introduced in the RNC and Node-B .....	142
Table 9 Cell Context Information Table (CCIT) .....	151
Table 10 FACH Information Table (FACH_IT) – 64 Kbps MBMS Streaming Video .....	154
Table 11 Simulation Parameters – Number of Zone Areas Vs Capacity efficiency and complexity ...	169
Table 12 Affect of number of Zone Areas on capacity efficiency (low loaded cell).....	169
Table 13 Affect of number of Zone Areas on capacity efficiency (medium loaded cell).....	170
Table 14 Affect of number of Zone Areas on capacity efficiency (high loaded cell).....	170
Table 15 Handover Information Table (HI_Table) .....	188
Table 16 MBMS service provision– Scenarios selected .....	202
Table 17 Simulation Parameters – Scenario 1: Pedestrian urban environment .....	204
Table 18 Simulation Parameters – Scenario 2: Low vehicular urban environment.....	205
Table 19 Simulation Parameters – Scenario 3: Vehicular urban environment .....	205
Table 20 Simulation Parameters – Scenario 4: Pedestrian urban environment with mix traffic .....	206
Table 21 MBMS Provision – Scenario 1 Results: Capacity and Channel Quality .....	208
Table 22 MBMS Provision - Scenario 1 Results: Context Reporting Request Process (70 UEs).....	214
Table 23 MBMS Provision – Scenario 1: Summary of Results presented .....	217
Table 24 MBMS Provision – Scenario 2 Results: Capacity and Channel Quality .....	218
Table 25 MBMS Provision - Scenario 2 Results: Context Reporting Request Process (70 UEs).....	223
Table 26 MBMS Provision – Scenario 2: Summary of Results presented .....	225
Table 27 MBMS Provision – Scenario 3 Results: Capacity and Channel Quality .....	226

Table 28 MBMS Provision - Scenario 3 Results: Context Reporting Request Process (70 UEs)..... 231

Table 29 MBMS Provision – Scenario 3: Summary of Results presented ..... 234

Christophoros Christophoros

# LIST OF FIGURES

Figure 1 Current 3GPP specified MBMS service provision approach .....	2
Figure 2 Signal Propagation Effects .....	18
Figure 3 Real coverage of Cellular Networks .....	19
Figure 4 Code Division Multiple Access (CDMA).....	22
Figure 5 OVSF Code Tree.....	22
Figure 6 UMTS network architecture.....	31
Figure 7 Allocation of bandwidth in WCDMA in the Time–Frequency–Code space.....	34
Figure 8 Multicasting in UMTS Networks prior MBMS .....	47
Figure 9 Phases of MBMS Multicast service provision .....	50
Figure 10 MBMS System Architecture .....	52
Figure 11 Initial Multicast approach in UMTS Vs MBMS approach.....	55
Figure 12 Types of inter-cell handovers introduced with MBMS .....	61
Figure 13 Scenario - Motivation for a new MBMS Handover control approach .....	66
Figure 14 MBMS Handover - Instance 1 (High noise in the Target cell) .....	67
Figure 15 3GPP handover control approach - QoS inefficiency occurred.....	67
Figure 16 MBMS Handover - Instance 2 (Low noise in the Target cell).....	68
Figure 17 3GPP handover control approach - Capacity inefficiency occurred .....	68
Figure 18 MBMS Handover control – Problem Formulation.....	72
Figure 19 Estimation of Handover Trigger Threshold (HTT).....	81
Figure 20 Estimation of Handover Activation Threshold (HAT).....	84
Figure 21 Proposed MBMS handover approach description.....	91
Figure 22 Flowcharts of Proposed MBMS Inter-cell Handover algorithm .....	96
Figure 23 Impact of the PP parameter on the QoS efficiency during an MBMS handover.....	98
Figure 24 Impact of the PP parameter on the capacity efficiency during an MBMS handover .....	99
Figure 25 MBMS Handover Control - Scenario 1 and Scenario 2 .....	112
Figure 26 MBMS Handover control - Scenario 3.....	113
Figure 27 MBMS Handover control - Multi-cell Scenario 4.....	114

Figure 28 MBMS Handover control - Multi-cell Scenario 5.....	115
Figure 29 MBMS Handover control - Scenario 1 Results: Pedestrian Environment (~6Km/h).....	117
Figure 30 MBMS Handover control - Scenario 1 Results: Vehicular Environment (~60Km/h).....	118
Figure 31 MBMS Handover control - Scenario 2 Results: Pedestrian Environment (~6Km/h).....	119
Figure 32 MBMS Handover control - Scenario 2 Results: Vehicular Environment (~60Km/h).....	120
Figure 33 MBMS Handover Control - Scenario 3 Results.....	122
Figure 34 MBMS Handover Control – Multi-cell Scenario 4 Results .....	125
Figure 35 MBMS Handover control – Multi-cell Scenario 5 Results .....	127
Figure 36 QoS received with Rate Splitting approach .....	136
Figure 37 “Dual transmission mode cell” concept .....	138
Figure 38 Need for co-existence and dynamic adaptation of P-t-P and P-t-M transmissions .....	140
Figure 39 FACH transmission power required to cover a specific area of the cell .....	140
Figure 40 Transmission power (capacity) requirements.....	142
Figure 41 Dual Transmission mode cell – Problem formulation.....	145
Figure 42 Dual Transmission mode cell – Introduction of Zone Areas.....	146
Figure 43 Cell with radius 1000 meters divided into 10 Zone Areas .....	155
Figure 44 Dual Transmission mode cell – Initialization phase pseudocode.....	162
Figure 45 Dual Transmission mode cell – MBMS Session ongoing phase pseudocode .....	166
Figure 46 Affect of period T on efficiency.....	167
Figure 47 Affect of number of Zone Areas on capacity efficiency (low loaded cell) .....	169
Figure 48 Affect of number of Zone Areas on capacity efficiency (medium loaded cell) .....	170
Figure 49 Affect of number of Zone Areas on capacity efficiency (high loaded cell) .....	170
Figure 50 Proposed Context Reporting Request Process - Flowchart .....	176
Figure 51 Ways in which an MBMS service maybe provided within a cell .....	182
Figure 52 Types of intra-cell handovers that might occur in a “Dual Transmission mode cell” .....	185
Figure 53 CPICH Ec/No Alteration rate experienced Vs Distance from the Node-B.....	187
Figure 54 Proposed intra-cell handover algorithm description.....	190
Figure 55 MBMS Provision - Scenario 1 Results: Capacity and Channel Quality (70 UEs).....	209
Figure 56 MBMS Provision - Scenario 1 Results: Capacity and Channel Quality (40 UEs).....	210
Figure 57 MBMS Provision - Scenario 1 Results: Capacity and Channel Quality (20 UEs).....	211

Figure 58 MBMS Provision - Scenario 1 Results: Number of context reports received (70 UEs).....	214
Figure 59 MBMS Provision - Scenario 1 Results: Actual Uplink Interference (70 UEs) .....	215
Figure 60 MBMS Provision - Scenario 1 Results: Aggregated Uplink Interference (70 UEs) .....	216
Figure 61 MBMS Provision - Scenario 2 Results: Capacity and Channel Quality (70 UEs) .....	219
Figure 62 MBMS Provision - Scenario 2 Results: Capacity and Channel Quality (40 UEs) .....	220
Figure 63 MBMS Provision - Scenario 2 Results: Capacity and Channel Quality (20 UEs) .....	221
Figure 64 MBMS Provision - Scenario 2 Results: Number of context reports received (70 UEs).....	222
Figure 65 MBMS Provision - Scenario 2 Results: Actual Uplink Interference (70 UEs) .....	224
Figure 66 MBMS Provision - Scenario 2 Results: Aggregated Uplink (70 UEs) .....	224
Figure 67 MBMS Provision - Scenario 3 Results: Capacity and Channel Quality (70 UEs) .....	227
Figure 68 MBMS Provision - Scenario 3 Results: Capacity and Channel Quality (40 UEs) .....	228
Figure 69 MBMS Provision - Scenario 3 Results: Capacity and Channel Quality (20 UEs) .....	229
Figure 70 MBMS Provision - Scenario 3 Results: Number of context reports received (70 UEs).....	231
Figure 71 MBMS Provision - Scenario 3 Results: Actual Uplink Interference (70 UEs) .....	232
Figure 72 MBMS Provision - Scenario 3 Results: Aggregated Uplink Interference (70 UEs) .....	233
Figure 73 MBMS Provision - Scenario 4 Results: Average Downlink Interference (dBm).....	235
Figure 74 MBMS Provision - Scenario 4 Results: Average Downlink Power for unicast services (watts) .....	235
Figure 75 WCDMA Radio Channels.....	257

## TABLE OF ACRONYMS

3G	3 <sup>rd</sup> Generation
3GPP	3rd Generation Partnership Project
4G	4 <sup>th</sup> Generation
AH	Activation Hysteresis
AR	Alteration Rate
At	Activation time
BER	Bit Error Rate
BLER	Block Error Rate
BMSC	Broadcast Multicast Service Centre
BoD	Bandwidth on Demand
BS	Base Station
CBS	Cell Broadcast Service
CCIT	Cell Context Information Table
CDMA	Code Division Multiple Access
CLPC	Closed Loop Power Control
CN	Core Network
CPICH	Common Pilot Channel
CPICH Ec/No AR	CPICH Ec/No Alteration Rate
CRC	Cyclic Redundancy Check
CS	Circuit Switched
DCH	Dedicated Channel
DS	Direct-Sequence
Eb/No	Energy per bit to noise power spectral density ratio
Ec/No	Energy per chip to noise power spectral density ratio
FACH	Forward Access Channel
FACH_IT	FACH Information Table
FDD	Frequency Division Duplex
FDMA	Frequency Division Multiple Access
GGSN	Gateway GPRS Support Node
GPRS	General Packet Radio Service
GPS	Global Positioning System
GSM	Global System for Mobile communications
HAA	Handover Activation Area
HAT	Handover Activation Threshold
HI_Table	Handover Information Table
HLR	Home Location Register
HSDPA	High Speed Downlink Packet Access
HTT	Handover Trigger Threshold
IGMP	Internet Group Management Protocol
IMSI	International Mobile Subscriber Identity



IP	Internet Protocol
ITU	International Telecommunication Union
LOS	Line of Sight
LTE	Long Term Evolution
MAI	Multiple Access Interference
MBMS	Multimedia Broadcast Multicast Service
MCCH	MBMS Point-to-Multipoint Control Channel
MD	Mobile Device
ME	Mobile Equipment
MGW	Media Gateway
MH	Mobile Handset
MS	Mobile Station
MSC/VLR	Mobile Services Switching Centre/Visitor Location Register
MTCH	MBMS Point-to-Multipoint Traffic Channel
NBAP	Node-B Application Protocol
OFDMA	Orthogonal Frequency Division Multiple Access
OLCP	Open Loop Power Control
OVSF	Orthogonal Variable Spreading Factor
PDP	Packet Data Protocol
PF	Probability Factor
PHEP	Practical Handover Execution Point
PLMN	Public Land Mobile Network
PN	Pseudo-Noise
PP	Pre-Trigger Predictor
PRACH	Physical Random Access Channel
PS	Packet Switched
P-t-M	Point-to-Multipoint
P-t-P	Point-to-Point
QoS	Quality of Service
RAB	Radio Access Bearer
RACH	Random Access Channel
RAN	Radio Access Network
RAT	Radio Access Technology
RF	Radio Frequency
RLC	Radio Link Control
RNC	Radio Network Controller
RNS	Radio Network Subsystem
RRC	Radio Resource Control
RRM	Radio Resource Management
S-CCPCH	Secondary Common Control Physical Channel
SCR	System Chip Rate
SF	Spreading Factor
SGSN	Serving GPRS Support Node
SIR	Signal to interference ratio

SM	Safety Margin
SNIR	Signal to Noise plus Interference Ratio
St	Safety time
TA	Transmission Arrangement
TDD	Time Division Duplex
TDMA	Time Division Multiple Access
TMGI	Temporary Mobile Group Identity
TPC	Transmission Power Command
TTI	Transmission Time Interval
UE	User Equipment
UMTS	Universal Mobile Telecommunications System
USIM	UMTS Subscriber Identity Module
UTRAN	UMTS Terrestrial Radio Access Network
WCDMA	Wideband Code Division Multiple Access
WiMAX	Worldwide Interoperability for Microwave Access
ZA	Zone Area
$\Delta t$	Handover delay time

# Chapter 1

## Introduction

Due to the rapid growth of mobile communications technology, the demand for wireless multimedia communications thrives in today's consumer and corporate market. The introduction in wireless networks of mobile TV, streaming video technologies and others, increased the need for communication between one sender and many receivers, leading to the need of Point-to-Multipoint transmission, achieved mainly through the use of multicasting technologies. A first successful attempt to provide efficient multicast service provision in wireless networks came with the introduction of Multimedia Broadcast Multicast Service (MBMS) system [1] [2] in Universal Mobile Telecommunications System (UMTS) Release 6 specifications [3]. The MBMS is a unidirectional (downlink only) bearer service, in which the same stream of data is transmitted from a single source entity to multiple recipients allowing the core- and radio- network resources to be shared more efficiently. With MBMS system deployment, popular download and streaming services scale with the number of users and can be delivered more efficiently, having significant core- and radio- resource savings.

As illustrated in Figure 1, with MBMS system, the Core Network (CN) sends only one stream of data to the Radio Network Controller (RNC), irrespective of the number of Node-Bs (also known as Base Stations (BSs)) or User Equipments (UEs) that want to receive it. Then,

it is up to the RNC to replicate and distribute, as efficiently as possible, the MBMS content to the UEs within the cells.

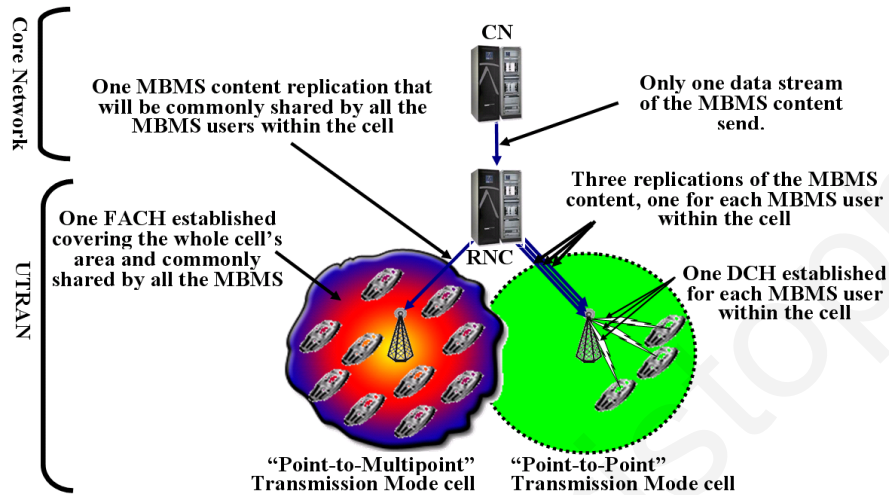

Figure 1 Current 3GPP specified MBMS service provision approach

According to the current 3GPP specified MBMS service provision approach [2], the MBMS content can be provided within a cell either by Point-to-Point (P-t-P) or Point-to-Multipoint (P-t-M) transmission mode, but not both at the same time. If P-t-P transmission mode is selected for a cell, one Dedicated Channel (DCH) is established for each UE within the cell that joined the MBMS service. Otherwise, if P-t-M transmission mode is selected, one Forward Access Channel (FACH) is established, allocating a fixed amount of transmission power (irrespective of the number of the UEs or their position within the cell), covering the whole cell's radio coverage area and commonly shared by all the UEs within. The decision of which transmission mode is going to be adopted is made by the RNC based on a radio resource efficiency criterion [2].

MBMS services due to their ability to deliver content efficiently to multiple users are considered by many as an effective means to provide multicast 'killer applications', and can thus become an attractive revenue generator both for the Network Operators and the Content Providers for the next years to come. Within the 3rd Generation Partnership Project (3GPP)

standards group, there is still a lot of ongoing work to define the appropriate standards for MBMS. Although the service and technical requirements are complete [1]-[6], still many design issues need to be considered for MBMS services to be provided in a more efficient way, especially in the UMTS Terrestrial Radio Access Network (UTRAN) part where the radio resources are limited.

The responsibility for the efficient utilization of the air interface resources in UTRAN lies in the Radio Resource Management (RRM). RRM involves strategies and algorithms for handover control, power control and congestion control with the main objective to utilize the limited radio spectrum resources and radio network infrastructure as efficiently as possible aiming to guarantee the Quality of Service (QoS), to maintain the planned coverage area, and to offer high network capacity and performance. Thus, without RRM, even the most efficient physical transmission system into the most sophisticated IP Core Network would fail. The RRM problem is inherent to any stand-alone wireless system. Until now, Network Operators of UMTS networks have only investigated RRM strategies for the resource management of unicast transmissions. However, with multicast transmissions operating in UMTS networks, the RRM problem becomes more complex, necessitating more advanced solutions.

### **1.1 Motivation and Ph.D. Thesis objectives**

Currently, the main problems with multimedia multicast services in wireless mobile networks concern quality and cost. As mentioned in [7], adopting the Radio Resource Management (RRM) algorithms currently specified in the 3GPP documents [2][8][9] to provide MBMS services can be very inefficient; e.g., more than 30% of the Node-B's total power has to be allocated to a single 64 Kbps MBMS service if full coverage is needed. This can make MBMS services too expensive since the overall UMTS network downlink capacity is limited by the Node-B's power source. MBMS services are still in the early stages, with the UTRAN the largest piece under test. The success of MBMS will depend greatly on the success of the UTRAN, because it provides the radio interface of UMTS. Thus, in order to

make MBMS services feasible and also attractable to the consumers, challenges are raised for the Network Operators for more efficient RRM algorithms in order to bring the price and quality of multimedia services in line with consumer expectations.

Motivated by the aforementioned, the general objective of this Ph.D. thesis is to investigate and propose efficient, scalable and effective RRM algorithms that will facilitate efficient multicast service provisioning within the radio access part of the UMTS networks. During our Ph.D. research we focused on the area of Handover Control and Power Control. In particular we analyse the new features introduced with MBMS, identify the factors that can influence the overall network capacity and performance during the MBMS service provisioning and proposed new handover and radio resource allocation solutions for controlling parameters such as transmit power, channel allocation, and handover criteria facilitating decisions targeting increased network capacity and overall system performance (and thus lower service costs), acceptably good Quality of Service (QoS) for the MBMS users, and seamless handovers (i.e., avoid any QoS degradation during handover), during the MBMS service provisioning.

From the surveyed literature, many schemes have been proposed for improving the MBMS service provisioning in UTRAN, but have identifiable inefficiencies. These are extensively discussed later in the thesis.

## **1.2 Work accomplished and Contributions**

In this section, the work accomplished during our research work in order to achieve the objectives of this Ph.D. dissertation is briefly presented. Our research work is performed in two parts. During the first part of our research we deal with MBMS handover control, while during the second part we deal with the efficient MBMS service provision in UTRAN.

### **1.2.1 Part 1 of Research: MBMS Handover Control**

During our research on MBMS handover control (see Chapter 3), we analysed the new mobility issues raised with MBMS and identified the new types of handovers introduced, that

is handovers between P-t-P (DCH) and P-t-M (FACH) transmission mode cells. These new types of handovers imposed new challenges (in term of network capacity and QoS) in the MBMS handover procedure that could not be efficiently addressed by the current 3GPP specified handover control solution [8][9] due to the approach used; implemented concerning only the characteristics of the DCH (which offers fast power control) and based on a comparison between the Common Pilot Channel (CPICH) signal quality received from the Base Stations (BSs) taking part in the handover procedure (see section 3.2). However, a vital aspect for achieving efficient MBMS handovers' execution lies in the consideration of the FACH capacity benefits and its bounded coverage characteristic, a feature not considered by the current 3GPP specified handover control approach.

Thus, by taking into consideration the FACH's capacity benefit and its bounded coverage characteristics, the aim of our proposed MBMS handover control approach is to guarantee the MBMS service QoS and achieve increased network capacity and performance during an MBMS handover. This is accomplished by following a different approach than the current 3GPP specified handover control algorithm. Instead of having as the main input of the handover triggering the comparison of the CPICH  $E_c/N_0$  signal quality received from all the BSs that take part in the handover process, we consider only the CPICH  $E_c/N_0$  signal quality received from the P-t-M transmission mode cell. This is a vital concern, since the main idea of our proposed MBMS handover control approach is to reduce the transmission power required in the P-t-P transmission mode cells by taking full advantage of the capacity benefits that FACH (i.e., the P-t-M transmission mode cells) offers. The key in accomplishing this, is to find the handover triggering threshold value that will force the UE to stay tuned to FACH as long as its signal strength is adequate (in case the UE is handing over from a P-t-M to a P-t-P transmission mode cell), or tune to FACH as soon as its signal strength becomes adequate (in case the UE is handing over from a P-t-P to a P-t-M transmission mode cell), to guarantee the reception of the service with the required QoS.

By considering a number of dynamic parameters, which are influenced by the UE's movement, a handover triggering threshold value is dynamically estimated by our algorithm running in the UE. This threshold value is compared, during the UE's mobility, only with the CPICH Ec/No signal quality received from the P-t-M transmission mode cell and aims to facilitate an efficient MBMS handover triggering at a point which will force execution (i.e., switch from DCH to FACH or vice versa) as close to the BS of the P-t-P transmission mode cell as possible, in order to reduce the downlink transmission power requirements for the DCH in the P-t-P transmission mode cell, but not outside of the P-t-M transmission mode cell's FACH supported area coverage limit, since outside of this area the signal strength of FACH is not strong enough for the UE to decode the signal correctly and thus a QoS degradation is experienced.

The proposed MBMS handover algorithm has been implemented in OPNET Simulator 11.0.A (see Appendix C) and evaluated using a series of simulations. In these simulations we have compared our proposed MBMS handover approach with the current 3GPP specified one and obtained results demonstrating significant benefits on:

- The **downlink network capacity** (significant transmission power savings are achieved),
- The **downlink channel quality experienced** by the UEs (by reducing the downlink transmission power used, less interference is caused and thus better channel quality is achieved)
- The **QoS experienced by the MBMS users** (eliminates any possibility for QoS degradation during an MBMS handover)

### **1.2.2 Part 2 of Research: Efficient MBMS Service provision in UTRAN**

The second part of our research, on the efficient MBMS service provision in UTRAN (see Chapter 4), was further subdivided into two steps. During the first step we deal with the efficient radio resource allocation in UTRAN and in the second one with a new efficient context reporting request process.



Through a number of representative scenarios we motivated the need for a new MBMS service provision approach, by highlighting the inefficiencies that can occur with the current 3GPP specified one [2]. Thus, we proposed a new MBMS service provision approach and a new radio resource allocation approach to address them. Our approach introduces a new type of cell in the MBMS service provisioning, called the “Dual Transmission mode cell”, in which P-t-P (i.e., DCHs) and P-t-M (i.e., FACH) transmissions can coexist and are allowed to dynamically adapt during the MBMS session. The main idea of introducing this new type of cell in the MBMS service provisioning is to take full advantage of the benefits that both transmission types can offer (i.e., the capacity benefits of FACH and the fast power control of DCH) and achieve increased radio network capacity and performance.

The “Dual Transmission mode cell” allows part of the cell’s area to be supported using FACH (“FACH supported area”) while the rest of it is supported using DCHs (“DCH supported area”). Both at session initiation and also during the session, the size of these areas is dynamically adapted (shrinks or expands by adapting the transmission power devoted to FACH and by releasing or establishing DCH connections), according to the instantaneous distribution and movement of the MBMS users within the cell, aiming to always support the requested Quality of Service (QoS) for all the MBMS users with the least amount of transmission power consumption. This new approach raised new mobility issues, more specifically intra-cell handovers between the “FACH supported area” and the “DCH supported area” that we also analysed and proposed a new intra-cell handover algorithm to address them. The proposed “Dual Transmission mode cell” approach has been implemented in OPNET Modeller 11.0.A (see Appendix C) and evaluated using a series of simulations. The performance evaluation carried out showed that our proposed “Dual Transmission mode cell” approach, provides considerable gains, as well as outperforms all other related approaches, such as “UE Counting”, “Power Counting”, “Rate Splitting”, and “FACH with Power Control”, in terms of:

- **Downlink network capacity** (significant downlink transmission savings have been achieved)
- **Channel quality experienced** by the UE (due to a reduction achieved on the downlink interference)

However, the tradeoff (with our initial effort to provide the “Dual Transmission mode cell” approach solution) were a small increase in the terminal battery consumption and the uplink noise rise due to the context reporting request process adopted (i.e., context reports were required to be received by all the MBMS users within the cell in order for a decision to be made). Note that the context reporting request process we initially adopted is the one used by the current 3GPP specified MBMS service provision approach which is described in [2].

Thus, to further enhance our “Dual Transmission mode cell” approach, achieve scalability and lessen the aforesaid tradeoffs, we proposed a new context reporting request process that managed to outperform all other related approaches, in all respects. With the new context reporting request process integrated, our proposed “Dual Transmission mode cell” approach, in addition to the capacity and channel quality gains previously mentioned, it also outperformed all other related approaches and:

- **Reduced the Terminal’s battery consumption** (since the need for frequent context reporting by the UEs is eliminated),
- **Reduced the uplink interference introduced** (since less UEs are required to report for a decision to be made),
- **Reduced the possibility for uplink congestion** (since not all the UEs are notified for reporting at the same time),
- **Reduced the processing effort required in the RNC as well as the time required for context reporting to finish** (since less context reports are considered) and thus **achieved faster decision making.**

### 1.3 Publications

In this section, we initially provide a complete list of publications and submissions directly stemming from the work in this thesis and then follow with other publications related to the efficient multicast service provision in Heterogeneous Network environments.

#### Journal Papers:

- C. Christophorou, A. Pitsillides, T. Lundborg, “Enhanced Radio Resource Management Algorithms for Efficient MBMS Service Provision in UTRAN”, Elsevier Computer Networks Journal (COMNET), February 2011, Volume: 55, Issue: 3, Pages: 689 - 710.  
DOI information: <http://dx.doi.org/10.1016/j.comnet.2010.10.010>.
- A. Pitsillides, C. Christophorou, “MBMS Handover Control: A New Approach for Efficient Handover in MBMS Enabled 3G Cellular Networks”, Elsevier Computer Networks Journal (COMNET), December 2007, ISSN: 1389-1286, Volume 51, Issue: 18, Pages: 4897 – 4918.  
DOI information: <http://dx.doi.org/10.1016/j.comnet.2007.08.005>.

#### Conference Papers:

- C. Christophorou, A. Pitsillides, “An enhanced MBMS service provision approach for improved performance in UTRAN”, 18th International Conference on Telecommunications (ICT 2011), 8 - 11 May 2011, Ayia Napa, Cyprus, Pages: 526 – 531.
- C. Christophorou, A. Pitsillides, “A NEHO based MBMS Handover Control Approach”, IEEE International Symposium on Personal, Indoor and Mobile Radio Communications 2008 (PIMRC 2008), 15 - 18 September 2008, Cannes, French Riviera, France, ISBN: 978-1-4244-2643-0, (5 Pages).

- C. Christophorou, A. Pitsillides, V. Vassiliou, “An Enhanced Radio Resource Allocation Approach for Efficient MBMS Service Provision in UTRAN”, IEEE International Symposium on Personal, Indoor and Mobile Radio Communications 2008 (PIMRC 2008), 15 - 18 September 2008, Cannes, French Riviera, France, ISBN: 978-1-4244-2643-0 (5 Pages).
- C. Christophorou, A. Pitsillides, “A new Approach for Efficient MBMS Service Provision in UTRAN”, IEEE Symposium on Computers and Communications 2008 (ISCC'08), 6 - 9 July 2008, Marrakech, Morocco, Pages: 356 – 361.
- C. Christophorou, A. Pitsillides, “An Enhanced Approach for Efficient MBMS Handovers in 3G Networks”, IEEE Symposium on Computers and Communications 2008 (ISCC'08), July 6 - 9, 2008, Marrakech, Morocco, Pages: 362 – 367.
- A. Panayides, C. Christophorou, J. Antoniou, A. Pitsillides, V. Vassiliou, “Power Counting for Optimized Capacity in MBMS Enabled UTRAN”, IEEE Symposium on Computers and Communications 2008 (ISCC'08), 6 - 9 July 2008, Marrakech, Morocco, Pages: 368 – 373.
- C. Christophorou, A. Pitsillides, N. Binucci, “Handover Control in MBMS Enabled 3G Mobile Cellular Networks”, 16th IST Mobile Summit & Wireless Communication Summit, Budapest, Hungary, 1 - 5 July 2007, CD – ROM Proceedings, ISBN: 978-963-8111-66-1 (5 pages).
- C. Christophorou, A. Pitsillides “Radio Resource Management in MBMS Enabled 3G Mobile Cellular Networks: A New Handover Control Approach”, 13th European Wireless 2007, Paris, France, April 2007, CD – ROM Proceedings, ISBN: 2-912328-41-1 (7 pages).
- C. Christophorou, A. Pitsillides, “An Efficient Handover Algorithm for MBMS Enabled 3G Mobile Cellular Networks”, IEEE Symposium on Computers and Communications (ISCC'06), 26-29 June 2006, Pula-Cagliari, Sardinia, Italy, Pages: 187 – 193.

- C. Christophorou, A. Pitsillides, “MBMS Handover Control for Efficient Multicasting in IP-Based 3G Mobile Networks”, IEEE International Conference on Communications 2006 (ICC 2006), 11-15 June 2006 , Istanbul, Turkey, Volume 5, Pages: 2112 – 2117.

Other own contributions related to mobility and efficient multicast service provision in 4th Generation Heterogeneous Networks, are the following:

**Journal Papers:**

- J. Antoniou, C. Christophorou, J. Simoes, A. Pitsillides, “Adaptive Network-Aided Session Support in Context-Aware Converged Mobile Networks” International Journal of Autonomous and Adaptive Communication Systems, March 2010.
- J. Antoniou, C. Christophorou, A. Neto, S. Sargento, F. Pinto, N. Carapeto, T. Mota, J. Simoes, A. Pitsillides, “Session and Network Support for Autonomous Context-Aware Multiparty Communications in Heterogeneous Mobile Systems” International Journal of Handheld Computing Research (IJHCR), December 2010, Volume: 1, No: 4, Pages: 1 – 24.

**Conference Papers:**

- N. Coutinho, S. Sargento, T. Condeixa, C. Janneteau, J. Simoes, C. Christophorou, F. Pinto, A. Neto, N. Carapeto, “Context-Aware Multiparty Services Delivery: Evaluation and Experimentation”, ICT Mobile Summit 2010, Florence, Italy, June 2010.
- J. Antoniou, C. Christophorou, C. Janneteau, M. Kellil, S. Sargento, A. Neto, F. C. Pinto, N. F. Carapeto, J. Simoes, “Architecture for Context-Aware Multicast Delivery in Mobile Heterogeneous Networks”, International Conference on Ultra Modern

Telecommunications 2009 (ICUMT 2009), 12 – 14 October 2009, St. Petersburg, Russia, Print ISBN: 978-1-4244-3942-3, Pages: 1-6.

- J. Antoniou, C. Christophorou, A. Neto, S. Sargento, F. C. Pinto, N. F. Carapeto, T. Mota, J. Simoes, A. Pitsillides, “Context-Aware Self-Optimization in Multiparty Converged Mobile Environments”, Third International ICST Conference on Autonomic Computing and Communication Systems (Autonomics 2009), 9-11 September 2009, Cyprus University of Technology, Limassol, Cyprus, Volume: 3, Part:1, Pages: 144 – 159.
- J. Simoes, S. Sargento, J. Antoniou, C. Christophorou, C. Janneteau, N. Carapeto, A. Neto, “Context-aware Control for Personalized Multiparty Sessions in Mobile Multihomed Systems”, 5th International Mobile Multimedia Communications Conference (MobiMedia 2009), 7-9 September 2009, London, United Kingdom, ISBN:978-963-9799-62-2.
- C. Janneteau, J. Simoes, J. Antoniou, C. Christophorou, M. Kellil, A. Klein, A. Neto, F. Pinto, P. Roux, S. Sargento, H. Shotten, J. Schneider, “Context-Aware Multiparty Networking“, ICT Mobile and Wireless Communications Summit, IIMC International Information Management Corporation, Spain, Santander, 10-12 June 2009, ISBN: 978-1-905824-12-0.

**Book Chapters:**

- J. Antoniou, C. Christophorou, J. Simoes, A. Pitsillides, “Network-Aided Session Management for Adaptive Context- Aware Multiparty Communications”, Book of Formal and Practical Aspects of Autonomic Computing and Networking: Specification, Development and Verification, IGI Global, 2010, (In print, 2011).

## 1.4 Thesis Overview

The current thesis is organized as follows:

Chapter 2 provides background knowledge related to the research area of this Ph.D. dissertation. More specifically a very brief introduction to the radio communication fundamentals and Cellular Networks is provided. The UMTS network is presented next, as well as the basic principles of Wideband Code Division Multiple Access (WCDMA), on which fundamental aspects of UMTS networks are based. Then, the different RRM algorithms used in UMTS are briefly discussed. Finally, an introduction to the MBMS system is provided, leading to the problems addressed by this thesis.

Chapter 3 deals with handover control issues introduced with MBMS. In this chapter related work performed on MBMS handover is presented and the need for a new handover control approach for MBMS is motivated. Then, the challenges we address in our design are identified, the problem is formulated and the proposed new handover control algorithm for MBMS is described. At the end of the chapter, the evaluation of our proposed MBMS handover control algorithm is presented.

Chapter 4 deals with the efficient provision of MBMS services in UMTS networks. In this chapter related work performed on the efficient MBMS service provisioning is presented and the need for the “Dual Transmission mode cell” is motivated by emphasizing the gains that can be achieved with this new concept. Then, the “Dual transmission mode cell” concept, the challenges we address in our design, and the problem formulation are described, followed by our proposed solution (algorithm) implementing this new concept. Next, the description of a new context reporting request process for acquiring the MBMS users’ context information required by our algorithm, is presented. After that, the new mobility issues introduced with this new “Dual Transmission mode cell” approach are identified, analysed and addressed. At the end of the chapter, the performance evaluation of the proposed “Dual Transmission mode cell” solution is presented, together with a comparative evaluation with other competing

approaches, such as “UE Counting”, “Power Counting”, “Rate Splitting”, and “FACH with Power Control”.

Finally, Chapter 5 summarizes the conclusions from both the MBMS handover control and the efficient MBMS service provision in UTRAN, and identifies opportunities for future work.

The WCDMA radio channels are described in Appendix A, while the MBMS specific WCDMA logical channels are described in Appendix B. In Appendix C, our enhanced MBMS simulator is described.



# Chapter 2

## Background Knowledge

This Chapter provides background knowledge related to the research area of this Ph.D. thesis. More specifically a brief introduction to the radio communication fundamentals and the Cellular Networks is provided. The Universal Mobile Telecommunications System (UMTS) network is presented in some detail, as well as the basic principles of Wideband Code Division Multiple Access (WCDMA), on which fundamental aspects of UMTS networks are based. Then, the different Radio Resource Management (RRM) algorithms used in UMTS are briefly discussed. Finally an introduction to the Multimedia Broadcast Multicast Service (MBMS) system is provided, leading to the problems which this thesis addresses. It is worth mentioning that the content of this Chapter is based on [1], [2], [22], [23], [24] and [25].

### 2.1 Radio Communication Fundamentals

The fundamental principles [22] of radio communication rely on utilising radio waves as a transmission medium. As a natural phenomenon, radio waves originate from electromagnetic fields. Under certain circumstances, time-dependent electromagnetic fields produce waves that radiate from the source to the environment. This source can be for example, a transmitter, like a Base Station (BS) or a Mobile Handset (MH). Radio waves and their characteristics are strictly dependent on the environment where the waves propagate. Correspondingly, a radio-

wave-based communication system is vulnerable to environmental factors (e.g., mountains, hills, huge reflectors like buildings, the atmosphere, and so on).

Every radio communication system consists of at least two elements: the transmitter and the receiver. In mobile systems, these two elements can also be integrated in one device (transceiver), enabling it to operate both as a transmitter and a receiver. An example of such a device is the Base Station (BS) and the Mobile Handset (MH) in any advanced public mobile system. Suppose that the BS acts as a transmitter source for a specific time in a certain environmental condition. The radio signal propagates from the BS to the MH at the speed of light and the received signal strength at the MH depends basically on the distance from the BS, the wavelength and the communication environment.

Environmental factors impeding radio wave propagation include any man-made or natural obstacle like high buildings, terrain and weather conditions, etc. They affect the path, phase and time of signal propagation when they traverse between the transmitter and receiver. Also, system parameters (e.g., antenna height and beam direction) have their own effect on propagation distance, signal strength and attenuation (loss of power). Therefore, the nature of radio communications inherently brings about some thorny limitations. The main problems that every radio communication system faces are as follows:

- Multipath propagation phenomenon
- Fading phenomenon
- Radio resource scarcity

Amongst them, multipath propagation is also considered by many as an advantage to radio communication because it enables the radio receiver to hear the BS even without signal Line of Sight (LOS). Despite this, it brings more complexity to the system by setting specific requirements and constraints on receiver and transmitter architecture. In order to understand the nature of a radio communication system the above-stated characteristics need to be well understood.

The factors that affect radio propagation are extremely dynamic, unpredictable and diverse. In addition to the attenuation caused by the distance between the sender and the receiver, there are several other effects that influence signal propagation. As shown in Figure 2, on its way from the transmitter to the receiver the radio wave experiences reflection, diffraction and scattering phenomena in addition to those components that travel directly (LOS) to the receiver. These together explain how radio waves can travel in a radio network environment even without a line of sight path

These propagation mechanisms lead to multipath propagation (reflected radio waves, which are copies of the same signal). Each signal copy will experience differences in attenuation, delay and phase shift while travelling from the source to the receiver. This can result in either constructive or destructive interference, amplifying or attenuating the signal power seen at the receiver. Strong destructive interference is frequently referred to as a deep fade and may result in temporary failure of communication due to a severe drop in the channel signal-to-noise ratio. As a result, the power of the received signal changes considerably over time as the receiver moves across even short distances. This effect is well known (and audible) with analog radios while driving. These quick changes in the received power are also called short-term fading (also known as fast fading). Slow fading, on the other hand, is a long-term fading effect changing the mean value of the received signal. Slow fading is usually associated with moving away from the transmitter and experiencing the expected reduction in signal strength. Typically, senders can compensate for slow fading by increasing/decreasing transmission power so that the received signal always stays within certain limits.

From the receiver's perspective and depending on the existing preconditions of any of the above-mentioned propagation events, the received signal power is affected randomly by each or a combination of them. In addition, device mobility, indoor and outdoor coverage, and hierarchical network structure raise some specific aspects about the propagation environment, which makes the situation more complicated to cope with.

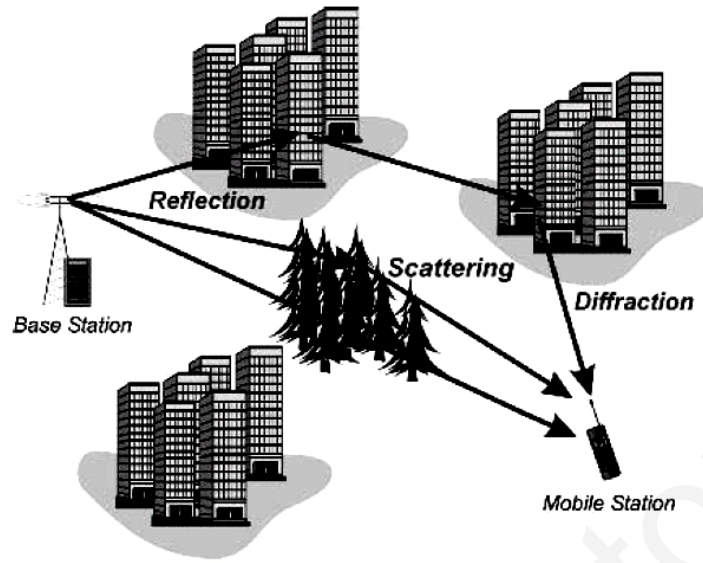

*Figure 2 Signal Propagation Effects*

In addition to fading and multipath phenomena, interference is an important problem for every radio communication system. The basic reason behind interference is the simultaneous connections to the Base Station, especially if a common set of frequencies are used. This forms perhaps the most dominant interference source in multi-access radio systems. Minimising the undesirable impact of fading and interference as well as optimising scarce radio resource usage are very dependent on the radio network planning employed, the utilised radio access techniques for controlling radio resources and the modulation techniques. A fundamental solution for alleviating the declining capacity of radio systems, as a result of pathloss, fading and interference is provided with the concept of the Cellular Networks.

## **2.2 Cellular Networks**

Cellular communications [23] has experienced explosive growth in the past two decades. Today millions of people around the world use cellular phones which allow a person to make or receive a call from almost anywhere. Cellular communications is supported by an infrastructure called a Cellular Network (see Figure 3). In a Cellular Network, a geographical area is split into many smaller areas, referred to as cells. Each cell is served by a fixed Base

Station, which is able to provide a radio link for a specific number of simultaneous users by emitting a low-level transmitted signal. The shape of the cells are never perfect circles or hexagons (see Figure 3), but depend on the environment (buildings, mountains, valleys, etc.), on weather conditions, and sometimes even on the number of users and load in the cell.

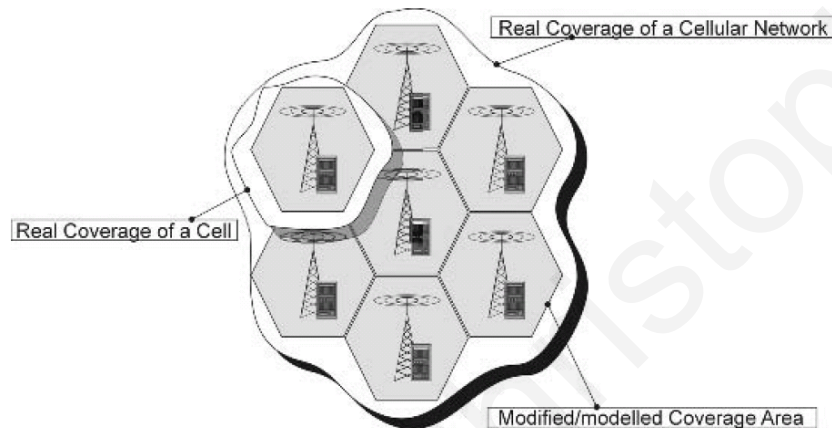

*Figure 3 Real coverage of Cellular Networks*

In this context, the question arises as to why mobile network providers install several thousands of Base Stations throughout the country (which is quite expensive) and do not use powerful transmitters with huge cells. To answer this question we provide the advantages of Cellular Networks with small cells below:

**Higher Capacity:** The increased capacity in a cellular network, compared with a network with a single transmitter, comes from the fact that the same radio frequency can be reused in different smaller areas for a completely different transmission (i.e., “frequency reuse” concept). With this concept, each BS (or cell) is assigned a group of frequency bands or channels. To avoid radio co-channel interference, the group of channels assigned to one cell must be different from the group of channels assigned to its neighbouring cells. However, the same group of channels can be assigned to two cells that are far enough apart such that the radio co-channel interference between them is within a tolerable limit. As most mobile phone systems assigned a certain frequency to a certain user, this frequency is blocked for other

users within the same cell. Thus, the number of concurrent users within a cell is limited. Huge cells do not allow for more users. On the contrary, they are limited to less possible users per  $\text{km}^2$ . This is also the reason for using very small cells in cities where many more people use mobile phones.

**Less Transmission power:** While transmission power aspects are not a big problem for Base Stations, they are in fact a very serious problem for Mobile Handsets which are powered by batteries. A Mobile Handset far away from the Base Station would need much more transmission power to reach the Base Station. Thus, with small cells the amount of transmission power required by the Mobile Handset to reach the Base Station is reduced, so phones can last longer between charges and batteries can be smaller. Moreover, lower power emissions help in addressing health concerns.

**Reduce Interference:** Having long distances between senders and receivers results in even more interference problems. With small cells and the use of “frequency reuse” concept, the problems of adjacent channel and co-channel hazards can be greatly reduced. The interference is reduced even further with the use of sectorized antennas. In sectoring, the cell remains the same, but the cell is divided into several sectors by using directional antennas at the Base Station instead of a single omnidirectional antenna. By doing this the radio co-channel interference is reduced since the number of the cells in a cluster is reduced.

**Robustness:** Cellular systems are decentralized and so, more robust against the failure of simple components. If one antenna fails this influences communication within a small area.

The cellular solution resolves the basic problems of radio systems in terms of radio system capacity constraints, but it encounters new problems, such as:

**Infrastructure needed:** Cellular systems need a complex infrastructure to connect all Base Stations. This includes many antennas, switches for call forwarding, location registers to find a Mobile Handset etc., which makes the whole system quite expensive.

**Problems due to mobility:** The Mobile Handset has to perform a handover when changing from one cell to another. Depending on the cell size and the speed of movement, this can happen quite often.

**Per-cell radio resource scarcity:** The primary objective of the cellular concept was to tackle capacity limitation, but it does not help per-cell capacity limitation on its own as far as simultaneous users are concerned. From the radio spectrum's standpoint, it is extremely important to know how radio resources are allocated to simultaneous users. Controlling radio resources has become one of the most critical features of any mobile network that serves a large number of subscribers. To address this issue different multiple access methods have been developed. The most popular of these methods are Frequency Division Multiple Access (FDMA), Time Division Multiple Access (TDMA), and Code Division Multiple Access (CDMA). Below we describe in more detail the CDMA method on which the radio interface of UMTS networks is based.

### **2.3 Code Division Multiple Access (CDMA)**

Code division multiple access (CDMA) [24] is a form of multiplexing and a method of multiple access that divides up a radio channel not by frequency (as in FDMA), nor by time (as in TDMA), but instead by using different pseudo-random code sequences for each user. CDMA (see Figure 4) employs spread-spectrum<sup>1</sup> technology and a special coding scheme (where each transmitter is assigned a code) to allow multiple users to be multiplexed over the same physical channel. Guard spaces are realized by using codes with the necessary 'distance' in code space, e.g., orthogonal codes. These codes are derived from an Orthogonal Variable Spreading Factor (OVSF) code tree (see Figure 5), and each user is given a different, unique code.

---

<sup>1</sup> Spread-spectrum techniques are methods by which a signal generated in a particular bandwidth is deliberately spread in the frequency domain, resulting in a signal with a wider bandwidth.

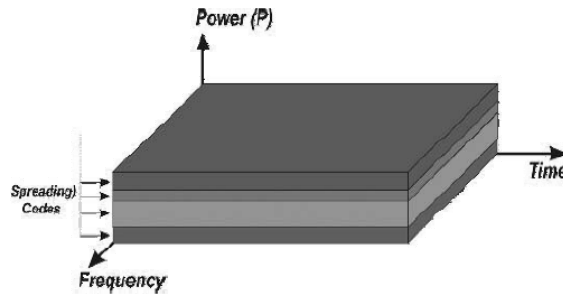

Figure 4 Code Division Multiple Access (CDMA)

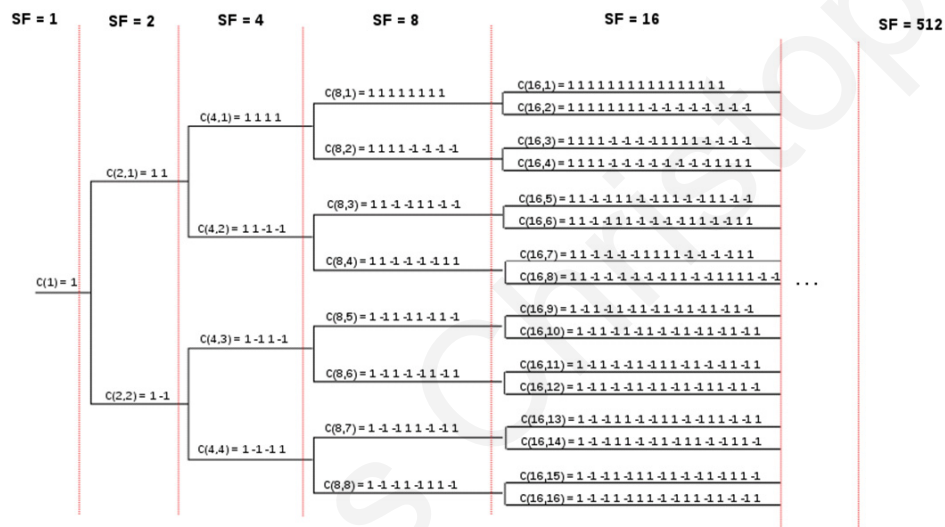

Figure 5 OVSF Code Tree

In contrast with FDMA and TDMA which are bandwidth limited, CDMA is interference limited multiple access system. Because all users transmit on the same frequency, internal interference generated by the system is the most significant factor in determining system capacity and call quality. The transmit power for each user must be reduced to limit interference, however, the power should be enough to maintain the required  $E_b/N_0$  (Energy per bit to noise power spectral density ratio) for a satisfactory call quality. In order to maximize the capacity of CDMA systems, it is important to control the signal level of each mobile so that its signal arrives at the cell site with the minimum required signal-to-noise ratio. If the signal is too low, the bit error rate increases. If the mobile sends too strong a signal, this will result in an increase of interference to all other mobile users sharing that



Radio Frequency (RF) carrier, which causes reduction in cell capacity. The goal is to have all of the mobiles to have about the same received power from the Node-B, otherwise some signals could drain others. The power is dynamically adjusted by reference to the demodulated Signal to Interference Ratio (SIR). Power control, both open loop and closed loop, is used to maintain the minimum power levels necessary for correctable communications errors while maximizing the capacity of the system.

The main advantage of CDMA for wireless transmission is that it gives good protection against interference and tapping. Different codes have to be assigned, but the code space is huge compared to the frequency space. Assigning individual codes to each sender does not usually cause problems. The main disadvantage of this scheme is the relatively high complexity of the receiver. A receiver has to know the code and must separate the channel with user data from the background noise composed of other signals and environmental noise. Additionally, a receiver must be precisely synchronized with the transmitter to apply the decoding correctly.

As a spread spectrum based radio access scheme, CDMA is perhaps one of the most sophisticated schemes that has been used in different mobile systems (particularly in UMTS). In general, CDMA belongs to two basic categories: synchronous (orthogonal codes) and asynchronous (pseudorandom codes). These two basic categories are further discussed below.

### **2.3.1 Synchronous CDMA**

Synchronous CDMA exploits at its core mathematical properties of orthogonality. Suppose we represent data signals as vectors. The binary string "1011" could be represented by the vector (1, 0, 1, 1). We use an operation on vectors, known as the dot product, to "multiply" vectors, by summing the product of the components. In the case where the dot product of two vectors is zero, the two vectors are said to be orthogonal to each other. Each user in synchronous CDMA uses a code orthogonal to the others' codes to modulate their signal. Orthogonal codes have a cross-correlation equal to zero; in other words, they do not interfere with each other. Although mutual orthogonality is the only condition, these vectors

are usually constructed for ease of decoding, for example columns or rows from Walsh matrices. An example of orthogonal vectors is provided below:

- $V_1 = (1, 1, 1, 1)$ ,
- $V_2 = (1, 1, -1, -1)$ ,
- $V_3 = (1, -1, -1, 1)$ ,
- $V_4 = (1, -1, 1, -1)$ ,

These vectors will be assigned to individual users and are called the code, chip code, or chipping code. The following example demonstrates how each user's signal can be encoded and decoded.

Each user is associated with a different code, say  $V$ . Associate a zero digit with the vector  $-V$ , and a one digit with the vector  $V$ . For example, if  $V = (1, -1, -1, 1)$  (this is the Spreading Code and in this case Spreading Factor is equal with 4), then the binary vector  $(1, 0, 1, 1)$  would correspond to  $(V, -V, V, V)$  which is then constructed in binary as  $((1, -1, -1, 1), (-1, 1, 1, -1), (1, -1, -1, 1), (1, -1, -1, 1))$  (this is the spread data). This constructed vector is called as the transmitted vector.

Each sender has a different, unique vector  $V$  (Spreading Code) chosen from that set, but the construction method of the transmitted vector is identical.

Now, the physical properties of interference say that if two signals at a point are in phase, they will "add up" to give twice the amplitude of each signal, but if they are out of phase, they will "subtract" and give a signal that is the difference of the amplitudes. Digitally, this behaviour can be modelled simply by the addition of the transmission vectors, component by component.

For example, if "Sender 1" has a Spreading Code  $(V_1) = (1, -1, -1, 1)$  and data  $(D_1) = (1, 0, 1, 1)$ , and Sender 2 has Spreading Code  $(V_2) = (1, 1, -1, -1)$  and data  $(D_2) = (0, 0, 1, 1)$ , and both senders transmit simultaneously, the coding steps illustrated in the following table will occur:

Step	Encode Sender 1
0	$V_1 = (1, -1, -1, 1), D_1 = (1, 0, 1, 1)$
1	Encode 1 = $(V_1, -V_1, V_1, V_1) =$ $((1, -1, -1, 1), (-1, 1, 1, -1), (1, -1, -1, 1), (1, -1, -1, 1))$
2	<b>Signal 1 = <math>(1, -1, -1, 1, -1, 1, 1, -1, -1, 1, 1, -1, -1, 1)</math></b>

Step	Encode Sender 2
0	$V_2 = (1, 1, -1, -1), D_2 = (0, 0, 1, 1)$
1	Encode 2 = $(-V_2, -V_2, V_2, V_2) =$ $((-1, -1, 1, 1), (-1, -1, 1, 1), (1, 1, -1, -1), (1, 1, -1, -1))$
2	<b>Signal 2 = <math>(-1, -1, 1, 1, -1, -1, 1, 1, 1, 1, -1, -1, 1, 1)</math></b>

Because Signal 1 and Signal 2 are transmitted at the same time into the same air, we'll add them together to model the raw signal in the air. This raw signal may be called an interference pattern.

$$\begin{aligned}
 \text{Interference Pattern} &= (1, -1, -1, 1, -1, 1, 1, -1, 1, -1, -1, 1, 1, -1, -1, 1) \\
 &+ (-1, -1, 1, 1, -1, -1, 1, 1, 1, 1, -1, -1, 1, 1, -1, -1) \\
 &= (0, -2, 0, 2, -2, 0, 2, 0, 2, 0, -2, 0, 2, 0, -2, 0)
 \end{aligned}$$

How does a receiver make sense of this interference pattern? The receiver knows the spreading codes of the senders, and this knowledge can be combined with the received interference pattern to extract an intelligible signal for any known sender. The following table explains how this process works.

Step	Decode Sender 1
0	$V_1 = (1, -1, -1, 1)$ , Interference Pattern = $(0, -2, 0, 2, -2, 0, 2, 0, 2, 0, -2, 0, 2, 0, -2, 0)$
1	Decode 1 = Interference_Pattern. $V_1 =$ $((0, -2, 0, 2), (-2, 0, 2, 0), (2, 0, -2, 0), (2, 0, -2, 0)).(1, -1, -1, 1) =$ $((0+2+0+2), (-2+0-2+0), (2+0+2+0), (2+0+2+0))$
2	<b>Data 1 = <math>(4, -4, 4, 4) = (1, 0, 1, 1)</math></b>

Step	Decode Sender 2
0	$V_2 = (1, 1, -1, -1)$ , Interference Pattern = $(0, -2, 0, 2, -2, 0, 2, 0, 2, 0, -2, 0, 2, 0, -2, 0)$
1	Decode 1 = Interference_Pattern. $V_2$ = $((0, -2, 0, 2), (-2, 0, 2, 0), (2, 0, -2, 0), (2, 0, -2, 0)).(1, 1, -1, -1) =$ $((0-2+0-2), (-2+0-2+0), (2+0+2+0), (2+0+2+0))$
2	<b>Data 2 = <math>(-4, -4, 4, 4) = (0, 0, 1, 1)</math></b>

Further, after decoding, all values greater than 0 are interpreted as 1 while all values less than zero are interpreted as 0. For example, after decoding, Data 1 is  $(4, -4, 4, 4)$ , but the receiver interprets this as  $(1, 0, 1, 1)$ .

As can be seen in the example shown above, the amplitude of the own signal increases on average by a factor of 4 relative to that of the user of the other interfering system, i.e., the correlation detection has raised the desired user signal by the spreading factor, here 4, from the interference present in the CDMA system. This effect is termed '**Processing Gain**' and is a fundamental aspect of all CDMA systems, and in general of all spread spectrum systems. Processing gain is what gives CDMA systems the robustness against self-interference that is necessary in order to reuse the available carrier frequencies (i.e., 5 MHz in W-CDMA) over geographically close distances.

Let's take an example with real W-CDMA parameters. Speech service with a bit rate of 12.2 kbps has a processing gain of 25 dB ( $10 \times \log_{10} (3.84\text{Mcps}/12.2\text{Kbps})$ ). After despreading, the signal power needs to be typically a few decibels above the interference and noise power. The required power density over the interference power density after despreading is designated as  $E_b/N_0$  (where  $E_b$  is the energy, or power density, per user bit and  $N_0$  is the interference and noise power density). For speech service  $E_b/N_0$  is typically in the order of 5 dB, and the required wideband Signal-to-Interference ratio is therefore 5 dB minus the processing gain (i.e.,  $5 - 25 = -20$  dB). In other words, the signal power can be 20 dB under the interference or thermal noise power, and the WCDMA receiver can still detect the signal. Since the wideband signal can be below the thermal noise level, its detection is

difficult without knowledge of the spreading sequence. For this reason, spread spectrum systems originated in military applications where the wideband nature of the signal allowed it to be hidden below the omnipresent thermal noise.

### 2.3.2 Asynchronous CDMA

The previous example of orthogonal Walsh sequences describes how 2 users can be multiplexed together in a synchronous system. The set of 4 Walsh orthogonal sequences shown in the example above will afford up to 4 users, and in general, an  $N \times N$  Walsh matrix can be used to multiplex  $N$  users. Synchronous CDMA requires all of the users to be coordinated so that each transmits their assigned sequence  $V$  (or the complement,  $-V$ ) so that they arrive at the receiver at exactly the same time. Thus, this technique finds use in Base-to-Mobile links, where all of the transmissions originate from the same transmitter and can be perfectly coordinated.

On the other hand, the Mobile-to-Base links cannot be precisely coordinated, particularly due to the mobility of the handsets, and requires a somewhat different approach. Since it is not mathematically possible to create signature sequences that are orthogonal for arbitrarily random starting points, unique "Pseudo-Random" or "Pseudo-Noise" (PN) sequences are used in Asynchronous CDMA systems. A PN code is a binary sequence that appears random but can be reproduced in a deterministic manner by the intended receivers. These PN codes are used to encode and decode a user's signal in Asynchronous CDMA in the same manner as the orthogonal codes in synchronous CDMA. These PN sequences are statistically uncorrelated, and the sum of a large number of PN sequences results in Multiple Access Interference (MAI) that is approximated by a Gaussian noise process (following the central limit theorem in statistics). If all of the users are received with the same power level, then the variance (e.g., the noise power) of the MAI increases in direct proportion to the number of users. In other words, unlike synchronous CDMA, the signals of other users will appear as noise to the signal of interest and interfere slightly with the desired signal in proportion to number of users.

All forms of CDMA use spread spectrum process gain to allow receivers to partially discriminate against unwanted signals. Signals encoded with the specified PN sequence (code) are received, while signals with different codes (or the same code but a different timing offset) appear as wideband noise reduced by the process gain.

Since each user generates MAI, controlling the signal strength is an important issue with CDMA transmitters. A synchronous CDMA, TDMA, or FDMA receiver can in theory completely reject arbitrarily strong signals using different codes, time slots or frequency channels due to the orthogonality of these systems. This is not true for Asynchronous CDMA; rejection of unwanted signals is only partial. If any or all of the unwanted signals are much stronger than the desired signal, they will overwhelm it. This leads to a general requirement in any asynchronous CDMA system to approximately match the various signal power levels as seen at the receiver. In CDMA cellular, the Base Station uses a fast closed-loop power control scheme to tightly control each mobile's transmit power and keep the target SIR in acceptable level. By doing this, increased Terminal's battery life and overall system capacity is achieved.

### **2.3.3 Spread-spectrum characteristics of CDMA**

Most modulation schemes try to minimize the bandwidth of the signal since bandwidth is a limited resource. However, spread spectrum techniques use a transmission bandwidth that is several orders of magnitude greater than the minimum required signal bandwidth. One of the initial reasons for doing this was military applications including guidance and communication systems. These systems were designed using spread spectrum because of its security and resistance to jamming. Asynchronous CDMA has some level of privacy built in because the signal is spread using a pseudorandom code; this code makes the spread spectrum signals appear random or have noise-like properties. A receiver cannot demodulate this transmission without knowledge of the pseudorandom sequence used to encode the data. CDMA is also resistant to jamming. A jamming signal only has a finite amount of power available to jam the signal. The jammer can either spread its energy over the entire bandwidth of the signal or jam only part of the entire signal.

CDMA can also effectively reject narrowband interference. Since narrowband interference affects only a small portion of the spread spectrum signal, it can easily be removed through notch filtering without much loss of information. Convolution encoding and interleaving can be used to assist in recovering this lost data. CDMA signals are also resistant to multipath fading. Since the spread spectrum signal occupies a large bandwidth only a small portion of this will undergo fading due to multipath at any given time. Like the narrowband interference this will result in only a small loss of data and can be overcome.

Another reason CDMA is resistant to multipath interference is because the delayed versions of the transmitted pseudorandom codes will have poor correlation with the original pseudorandom code, and will thus appear as another user, which is ignored at the receiver. In other words, as long as the multipath channel induces at least one chip of delay, the multipath signals will arrive at the receiver such that they are shifted in time by at least one chip from the intended signal. The correlation properties of the pseudorandom codes are such that this slight delay causes the multipath to appear uncorrelated with the intended signal, and it is thus ignored.

Some CDMA devices use a rake receiver, which exploits multipath delay components to improve the performance of the system. A rake receiver combines the information from several correlators, each one tuned to a different path delay, producing a stronger version of the signal than a simple receiver with a single correlator tuned to the path delay of the strongest signal.

Frequency reuse is the ability to reuse the same radio channel frequency at other cell sites within a cellular system. In the FDMA and TDMA systems frequency planning is an important consideration. The frequencies used in different cells must be planned carefully to ensure signals from different cells do not interfere with each other. In a CDMA system, the same frequency can be used in every cell, because channelization is done using the pseudorandom codes. Reusing the same frequency in every cell eliminates the need for frequency planning in a CDMA system; however, planning of the different pseudorandom

sequences must be done to ensure that the received signal from one cell does not correlate with the signal from a nearby cell.

Since adjacent cells use the same frequencies, CDMA systems have the ability to perform soft handoffs. Soft handoffs allow the mobile phone to communicate simultaneously with two or more cells. The best signal quality is selected until the handoff is complete. This is different from hard handoffs utilized in other cellular systems. In a hard handoff situation, as the mobile telephone approaches a handoff, signal strength may vary abruptly. In contrast, CDMA systems use the soft handoff, which is undetectable and provides a more reliable and higher quality signal.

## **2.4 Universal Mobile Telecommunications System (UMTS)**

The Universal Mobile Telecommunication System (UMTS) [25] is a 3<sup>rd</sup> Generation (3G) wireless system that delivers high-bandwidth data and voice services to mobile users and also provides access to the web with higher data rates. UMTS evolved from Global Systems for Mobile communications (GSM). UMTS has an air interface based on W-CDMA (Wideband-Code Division Multiple Access) and an Internet Protocol (IP) core network based on General Packet Radio Service (GPRS).

### **2.4.1 UMTS network architecture**

The main components of a UMTS system (see Figure 6) are the Core Network (CN), which is responsible for switching and routing calls and data connections to external networks and the UMTS Terrestrial Radio Access Network (UTRAN) that handles all radio-related functionality. To complete the system, the User Equipment (UE) that interfaces with the user and the radio interface is defined. The UE consists of two parts:

- The Mobile Equipment (ME) is the radio terminal used for radio communication over the Uu interface.



- The UMTS Subscriber Identity Module (USIM) is a smartcard that holds the subscriber identity, performs authentication algorithms, and stores authentication and encryption keys and some subscription information that is needed at the terminal.

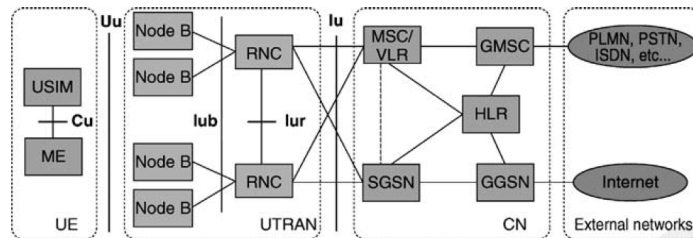

Figure 6 UMTS network architecture

The main task of UTRAN is to create and maintain Radio Access Bearers (RAB) for communication between the UE and the CN so that End-to-End QoS requirements are fulfilled in all respects. With RAB, the CN elements are given an “illusion” about a fixed communication path to UE, thus releasing them from the need to take care of radio communication aspects. The UTRAN is divided into Radio Network Subsystems (RNSs). One RNS consists of a set of radio elements called Base Stations (or officially Node-B), realizing the Uu interface, and their corresponding controlling element that is called Radio Network Controller (RNC). The RNSs are communicating with each other through Iur interface, forming connection between two RNCs. This Iur open interface carries both signalling and traffic information.

The main task of the Base Station (BS) is to establish the physical implementation of the Uu interface (communication with the UE) and the implementation of Iub interface (communication with the RNC). Realization of the Uu interface means that the Base Station implements WCDMA radio access Physical Channels and transfer information from Transport Channels to the Physical Channels based on arrangements determined by the RNC (QoS parameters, Channel data rate, Spreading code etc.). The term Physical Channels means different kinds of bandwidth allocated for different purposes over the Uu interface. In other

words the Physical Channels form the physical existence of Uu interface between the UE and the UTRAN. The physical channels exist in the Uu interface, and the RNC is not necessarily aware of their structure at all.

The Radio Network Controller (or RNC) is a governing element in the UTRAN and is responsible for controlling the radio resources of the Node-Bs that are connected to it. The major functionality of the RNC is the Radio Resource Management (RRM). The RRM is a collection of algorithms used to guarantee the stability of the radio path and the QoS of radio connection by efficient sharing and managing of radio resources. The RNC connects to the Circuit Switched Core Network through Media Gateway (MGW) and to the SGSN (Serving GPRS Support Node) in the Packet Switched Core Network.

The main elements of the Core Network are as follows:

- Home Location Register (HLR) is a database located in the user's home system that stores the master copy of the user's service profile. For the purpose of routing incoming transactions to the UE (e.g. calls or short messages), the HLR also stores the UE location on the level of MSC/VLR and/or SGSN, i.e., on the level of the serving system.
- Mobile Services Switching Centre/Visitor Location Register (MSC/VLR) is the switch (MSC) and database (VLR) that serves the UE in its current location for Circuit Switched (CS) services. The MSC function is used to switch the CS transactions, and the VLR function holds a copy of the visiting user's service profile, as well as more precise information on the UE's location within the serving system. The part of the network that is accessed via the MSC/VLR is often referred to as the Circuit Switched (CS) domain.
- GMSC (Gateway MSC) is the switch at the point where UMTS PLMN is connected to external CS networks. All incoming and outgoing CS connections go through GMSC.

- SGSN (Serving GPRS Support Node) has functionality similar to that of the MSC/VLR but it is typically used for Packet Switched (PS) services. The part of the network that is accessed via the SGSN is often referred to as the Packet Switched (PS) domain.
- GGSN (Gateway GPRS Support Node) is the switch at the point where UMTS Public Land Mobile Network (PLMN) is connected to external PS networks. All incoming and outgoing PS connections go through GGSN.

The external networks can be divided into two groups:

- CS Networks: These provide circuit-switched connections, like the existing telephony service. ISDN and PSTN are examples of CS networks.
- PS Networks: These provide connections for packet data services. The Internet is one example of a PS network.

#### **2.4.2 Wideband Code Division Multiple Access (WCDMA)**

WCDMA is a 3G standard based on CDMA (the basic CDMA principles are described in section 2.3) that increases the throughput of data transmission of CDMA by using a wider 5 MHz carrier than the standard CDMA, which uses a 1.25 MHz carrier, hence the name W (Wideband) - CDMA. It was adopted as a standard by the International Telecommunication Union (ITU) under the name "IMT-2000 Direct Spread". WCDMA is the technology used in UMTS, and with data rates up to 2 Mbits it has the capacity to easily handle bandwidth-intensive applications such as video, data, and image transmission necessary for mobile internet services.

WCDMA is a wideband Direct-Sequence Code Division Multiple Access (DS-CDMA) system, i.e. user information bits are spread over a wide bandwidth by multiplying the user data with quasi-random bits (called chips) derived from CDMA spreading codes. In order to support very high bit rates (up to 2 Mbps), the use of a variable Spreading Factor and multicode connections is supported. An example of this arrangement is shown in Figure 7.

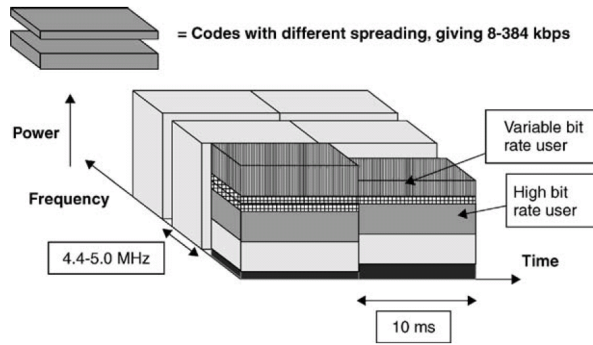

Figure 7 Allocation of bandwidth in WCDMA in the Time-Frequency-Code space

How widely the signal is spread depends on the Spreading Factor used in association with it. The Spreading Factor is a multiplier describing the number of chips used in the WCDMA radio path per 1 symbol. In the case of DS (Direct Sequence) WCDMA FDD (Frequency Division Duplex), 1 symbol transmitted in an uplink direction represents 1 bit and 1 symbol transmitted in the downlink direction represents 2 bits. This difference is due to the different modulation methods used in uplink and downlink directions. All WCDMA variants used in 3G networks used a “System Chip Rate” (SCR) equal to 3.84 Mchip/s (megachips per second). Another name for Spreading Factor is Processing Gain (Gp), and it can be expressed as a function of the bandwidths used. Processing gain is what gives CDMA systems the robustness against self-interference that is necessary in order to reuse the available 5 MHz carrier frequencies over geographically close distances.

$$G_p = \frac{\text{System\_Chip\_Rate}}{\text{Bearer\_Bit\_Rate}} = \text{Spreading\_Factor}$$

The chip rate of 3.84 Mcps leads to a carrier bandwidth of approximately 5 MHz. DS-SS-SSMA systems with a bandwidth of about 1 MHz, such as IS-95, are commonly referred to as narrowband CDMA systems. The inherently wide carrier bandwidth of WCDMA supports high user data rates and also has certain performance benefits, such as increased multipath diversity.

WCDMA supports highly variable user data rates, in other words the concept of obtaining Bandwidth on Demand (BoD) is well supported. The user data rate is kept constant during each 10 ms frame. However, the data capacity among the users can change from frame to frame. This fast radio capacity allocation will typically be controlled by the network to achieve optimum throughput for packet data services.

WCDMA supports two basic modes of operation: Frequency Division Duplex (FDD) and Time Division Duplex (TDD). In the FDD mode, separate 5 MHz carrier frequencies are used for the uplink and downlink respectively, whereas in TDD only one 5 MHz is timeshared between the uplink and downlink. Uplink is the connection from the Mobile to the Base Station, and downlink is that from the Base Station to the Mobile.

WCDMA supports the operation of asynchronous Base Stations, so that, unlike in the synchronous IS-95 system, there is no need for a global time reference such as a GPS. Deployment of indoor and micro Base Stations is easier when no GPS signal needs to be received.

WCDMA employs coherent detection on uplink and downlink based on the use of pilot symbols or common pilot. While already used on the downlink in IS-95, the use of coherent detection on the uplink is new for public CDMA systems and will result in an overall increase of coverage and capacity on the uplink.

The WCDMA air interface has been crafted in such a way that advanced CDMA receiver concepts, such as multiuser detection and smart adaptive antennas, can be deployed by the network operator as a system option to increase capacity and/or coverage. In most second generation systems no provision has been made for such receiver concepts and as a result they are either not applicable or can be applied only under severe constraints with limited increases in performance.

## 2.5 Radio Resource Management

The Radio Resource Management (RRM) [22] is a responsibility solely taken care of by the UTRAN. RRM is located in both the UE and the RNC inside the UTRAN. It contains various algorithms, which aim to stabilize the radio path, enabling it to fulfil the QoS criteria set by the service using the radio path. The control protocol used for this purpose is the Radio Resource Control (RRC) protocol [9].

There are three main functions of radio resource management.

- Handover Control
- Power Control
- Congestion Control

Congestion control is subdivided into the three functions which are:

- Call Admission control
- Load control
- Packet scheduling control

In particular, during our Ph.D. research we focused on the area of Handover Control and Power Control. We analyse the new features introduced with MBMS, identify the factors that can influence the overall network capacity and performance during the MBMS provision and propose new algorithms and solutions for controlling parameters such as handover criteria (during the mobility of an MBMS user across the cell boundaries, see Chapter 3), transmit power and dynamic channel allocation during the MBMS service provisioning (see Chapter 4), targeting increased overall network capacity and performance.

### 2.5.1 Handover Control

Handover control (also referred as Handoff control) aims to provide continuity of mobile services to a user travelling over cell boundaries in a cellular infrastructure. The basic concept of handover control is that when the subscriber moves from the coverage area of one cell to another, a new connection with the new target cell has to be set-up and the connection with

the old cell may be released. The whole process of tearing down the existing connection in the current cell and establishing a new connection in the appropriate cell is called “handover”.

There are many reasons why handover procedures may be activated. The basic reason behind a handover is that the air interface connection between the UE and UTRAN does not fulfil the QoS criteria set for that connection and thus the UE or the UTRAN initiates actions in order to improve the connection.

For example a signal quality reason handover occurs when the quality or the strength of the radio signal falls below certain parameters specified in the RNC. A traffic reason handover occurs when the traffic capacity of a cell has reached its maximum or is approaching it. In such a case, the UE near the edges of the cell with high load may be handed over to neighbouring cells with less traffic load.

The number of handovers depends on the degree of UE mobility. It is obvious that the faster the UE is moving, the more handovers it causes to the UTRAN. The decision to perform a handover is always made by the RNC that is currently serving the subscriber.

There are the following categories of handover:

- Hard Handover
- Soft Handover
- Softer Handover

Hard handover means that all the old radio links in the UE are removed before the new radio links in the new cell are established. Hard handover can be seamless or non-seamless. Seamless hard handover means that the handover is not perceptible to the user (i.e., no QoS degradation is experienced). In practice a handover that requires a change of the carrier frequency (inter-frequency handover) is always performed as a hard handover.

Soft handover is an innovation in mobility management introduced by CDMA which improves signal quality and handover robustness compared to TDMA systems. It refers to a technique in which a UE can be served by more than one BS at the same time. During a soft handover, a UE is in the overlapping cell coverage area of two sectors belonging to different

BSs. The communications between the UE and the BSs takes place concurrently via two air interface channels, one from each BS. Both channels (signals) are received at the mobile station by maximal ratio combining rake processing. In the uplink direction the code channel of the UE is received from both BSs, but the received data is then routed to the RNC for combining. This is typically done so that the same frame reliability indicator as provided for outer loop power control is used to select the better frame between the two possible candidates within the RNC. Note that during soft handover two power control loops per connection are active, one for each BS.

Softer handover is a special case of soft handover where the radio links, that are added and removed from a connection, belong to the same BS. During softer handover, a UE is in the overlapping cell coverage area of two adjacent sectors of a BS. The communications between the UE and the BS take place concurrently via two air interface channels, one for each sector separately. This requires the use of two separate codes in the downlink direction, so that the UE can distinguish the signals. The two signals are received in the UE by means of Rake processing, very similar to multipath reception, except that the fingers need to generate the respective code for each sector for the appropriate despreading operation. In softer handover, macro-diversity with maximum ratio combining can be performed in the UE. In the uplink direction a similar process takes place at the BS: the code channel of the UE is received in each sector, then routed to the same baseband Rake receiver and the maximal ratio combined there in the usual way. During softer handover only one power control loop per connection is active.

We also note that soft and softer handover can take place in combination with each other. These CDMA-specific handover types are essential, as without these soft/softer handover techniques there would be near-far scenarios of a UE penetrating from one cell deeply into an adjacent cell without being power-controlled by the latter. Very fast and frequent hard handovers could largely avoid this problem; however, they can be executed only with certain



delays during which the near–far problem could develop. So, as with fast power control, soft/softer handovers are an essential interference-mitigating tool in WCDMA.

### 2.5.1.1 Handover Process

The basic handover process consists of three main phases. These are the Measurement phase, the Decision phase, and the Execution phase.

**Handover Measurement** provision is a very important task for the system performance. This is because the signal strength of the radio channel may vary drastically due to fading and signal path loss, resulting from the cell environment (e.g. buildings, mountains) and user mobility. For the handover purposes and during the connection the UE continuously measures the Common Pilot Channel (CPICH) signal quality concerning the neighbouring cells, and reports the results to the serving RNC.

Accurate measurements of the CPICH signal quality, are necessary for making handover decisions. Cell measurements are filtered in the UE and based on the measurement reporting criteria a report is sent to the UTRAN. This report constitutes the basic input to the handover algorithm. Based on the cell measurements, the handover algorithm evaluates if any cell should be added to (Radio Link Addition), removed from (Radio Link Removal), or replaced in (Combined Radio Link Addition and Removal) the Active Set (a list of the Base Stations through which the UE has simultaneous connection to the UTRAN) using the "Active Set Update" procedure.

It is important to apply filtering on the handover measurements to average out the effect of fast fading. Measurement errors can lead to unnecessary handovers. Appropriate filtering can increase the performance significantly. As long filtering periods can cause delays in the handovers, the length of the filtering period has to be chosen as a trade-off between measurement accuracy and handover delay. Also the speed of the user matters, the slower the user is moving the harder it is to average out the effects of fast fading. Often a filtering time of 200ms is chosen.

**Decision phase** consists of the assessment of the overall QoS of the connection and its comparison with the requested QoS attributes and estimates measured from the neighbouring cells. Depending on the outcome of this comparison, the handover procedure may or may not be triggered. The RNC checks whether the values indicated in the measurement reports meet the QoS specified for the end-user service. If not, then it allows the **Execution of the handover**.

### 2.5.2 Power Control

The main reasons for implementing power control are the “near-far” problem, the interference-dependent capacity of the WCDMA and the limited power source of UE. For that reasons, the radio transmission power should be optimized, meaning that the power of every transmitter is adjusted to the level requested QoS. In WCDMA systems, power control is applied with purpose to reduce the intra-cell interference.

WCDMA is interference-limited and not bandwidth-limited. Therefore, system capacity is maximized if the transmitted power of the signal of each terminal is controlled so that its signal arrives at the BS with the minimum Signal to Interference Ratio (SIR). Let us assume that a terminal is transmitting a signal to a BS. If the terminal’s signal arrives at the BS with a too low power value, then the required QoS for the radio connection cannot be met. If the received power value is too high, the performance of the terminal is good; however, interference to all other terminals is increased and may result in unacceptable performance for other users, unless their number is reduced. So, system capacity is maximized if the transmitted power of each terminal is controlled so that its signal arrives at the BS with the minimum required Signal to Interference Ratio (SIR).

Due to the fact that in the WCDMA system the total bandwidth is shared simultaneously, other users can experience a noise-like interference from a specific user. In case the power control mechanism is missing, common sharing of the bandwidth creates a severe problem, referred to as the near-far effect. In a near-far situation, the signal of the terminal that is close

to the serving BS may dominate the signal of those terminals, which are far away from the same BS causing interference to their signal.

To manage the power control properly in WCDMA, the system uses two different defined power control mechanisms. These power control mechanisms are:

- the Open Loop Power Control (OLPC) and
- the Closed Loop Power Control (CLPC), with two constituents:
  - Inner Power Control and
  - Outer Loop Power Control.

These power control mechanisms work together, in order to keep the target SIR at an acceptable level. Also these power control mechanisms (OLPC and CLCP) working together have considerable impact on the terminal's (UE) battery-life and overall system capacity.

#### **2.5.2.1 Open Loop Power Control (OLPC)**

In the Open Loop Power Control (OLPC), which is basically used for the uplink power adjusting, the UE adjusts the power based on an estimate of the received signal level for the BS CPICH when the UE is in idle mode. For example, in the OLPC, the UE estimates the transmission signal strength by measuring the received power level of the CPICH signal from the BS in the downlink, and adjusts its transmission power in a way that is inversely proportional to the pilot signal power level. Consequently, the stronger the received pilot signal, the lower the UE transmitted power.

For the reason that fading characteristics of the radio channel vary rapidly and independently for the uplink and the downlink, OLPC alone is not adequate for adjusting the UE transmission power. In order to compensate the rapid changes in the signal strength, Closed Loop Power Control (CLPC) is also needed.

#### **2.5.2.2 Closed Loop Power Control (CLPC)**

In contrast with OLPC, CLPC is utilized for adjusting the power when the radio connection has already been established. Its main target is to compensate the effect of rapid

changes in the radio signal strength (due to the radio path environment, mobility etc.) and hence it should be fast enough to respond to these changes. CLPC includes Inner and Outer Loop Power Control.

#### **2.5.2.2.1 Inner Loop Power Control**

In the case of the uplink CLPC mechanism, the BS issues commands to the UE to either increase or decrease its transmission power with a cycle of 1.5 KHz (1500 times per second) by 1, 2 or 3 dB step-sizes. The decision whether to increase or decrease the power, is based on the received SIR estimated by the BS. When the BS receives the UE signal it compares the signal strength with the pre-defined threshold value at the BS. If the UE transmission power exceeds the threshold value, the BS sends a Transmission Power Command (TPC) to the UE to decrease its signal power. If the UE transmission power is lower than the threshold target, the BS sends a TPC to the UE to increase its signal power.

In the case of the downlink CLPC mechanism the roles of the BS and the UE are interchanged. That is, the UE compares the received signal strength from the BS with a predefined threshold and sends the TPC to the BS to adjust its transmission power accordingly.

The Inner Loop is the fastest loop in WCDMA power control and hence it is occasionally referred to as the Fast Power Control.

#### **2.5.2.2.2 Outer Loop Power Control**

The main target of OLPC is to keep the target SIR for the uplink Inner Loop Power Control at an acceptable quality level. Thanks to macro-diversity<sup>2</sup>, the RNC is aware of the current radio connection conditions and quality. Therefore, the RNC is able to define the allowed power levels of the cell and target SIR to be used by the BS when determining the

---

<sup>2</sup> Macro-diversity is a kind of space diversity scheme using several receiver antennas and/or transmitter antennas for transferring the same signal.

TPCs (Transmission Power Commands). In order to maintain the quality of the radio connection, the RNC uses this power control method to adjust the target SIR and keep the variation of the quality of the connection in control. In fact, Outer Loop Power Control fine-tunes the performance of the Inner Loop Power Control.

This method aims at maintaining the quality of communication, while preventing capacity waste and using as low power as possible. With a frequency varying between 10 and 100 Hz, the received and the desired quality of both uplink and downlink SIR are compared. If the received quality is better than the quality that has to be achieved, the SIR target is decreased; in the other case the SIR target is increased.

### **2.5.3 Congestion control**

Congestion control is important to keep the radio interface load under predefined thresholds to guarantee the availability of required resources for a call. Overloading causes problems in terms of lower capacity, quality of service degradation, and unavailability of services in the planned coverage area, or to put it in simple terms it “destabilizes” the network.

Congestion control is subdivided into three functions

- Call Admission Control
- Load Control
- Packet Scheduling Control

Call Admission Control (CAC), takes place in the RNC and has the function to regulate and provide resources for new call requests or already ongoing calls. CAC also ensures the quality of service for the calls in terms of required radio resources.

Load control maintains the radio resources of the network within the given limits of Quality of Service. The main objective of load control is to ensure that the network is not overloaded and remains stable. If the network becomes overloaded, then load control performs some actions to quickly decrease the load to the limits to decrease the interference and maintained the QoS and planned coverage.

Packet scheduling control is done by the RNC in UMTS with functionality to control the packet access. Packet Scheduling control provides appropriate radio resources for data calls. Packet scheduling control algorithms work with call admission control and load control algorithms in order to prevent the radio network from congestion and maintain the QoS.

## **2.6 Multicasting in UMTS Networks**

In today's life, and especially in a business environment, fixed and mobile communication are becoming increasingly critical. Traditionally, data communications have been between one sender and one receiver. However, with the introduction of technologies such as video conferencing, streaming media and others, there is an increasing need for communication between one sender and many receivers, or even many senders and many receivers. Thus, the need for efficient broadcast and multicast communications has emerged.

With broadcast delivery method, the sender transmits to all receivers within an area. While this is appropriate if all receivers, or at least most of them, are interested in the sender's transmission, it is very wasteful if only a few receivers are interested. In a wireless mobile network, broadcast transmissions not only waste network resources, but also receiver resources, since the receiver must consume energy in order to process useless data.

Multicast is termed as the communication where a piece of information is sent from one or more points to a specific set of receivers within an area, with a single send operation. In this type of communication, there may be one or more senders, and the information is distributed to a set of receivers forming the multicast group. Within the context of multicast, various types of multicast communication can be differentiated, depending on the number of senders and receivers. For example, if we have only one sender sending to a multicast group then we are talking about one-to-many multicast applications; otherwise, if we have more than one sender then we are talking about many-to-many applications. The one-to-many multicast application implies one source and a set of receivers. Examples of one-to-many applications are streaming media distribution, push media (e.g., weather updates, sports scores), and file

distribution. The many-to-many multicast application implies any number of hosts sending to the same multicast group address, as well as receiving from it. For example, multimedia conferencing, shared distributed databases, distributed parallel processing, shared document editing, distance learning, chat groups, multi-player games, are multicast applications in which each member may receive data from multiple senders while it sends data to all of them.

Multicast data delivery increases network efficiency and decreases server load by eliminating the need for redundant packets when more than one client wishes to access a data stream. When the network is aware of the fact that multiple receivers are targeted, it can create a distribution tree from the sender towards all receivers overlaying the actual network topology. The data injected at the root of this tree by the sender are duplicated only at branching points of the tree towards the receivers. Thus, instead of sending many streams of packets from the sender, one to each listener, with multicast all of the listeners downstream a tree listen to one and the same stream. This avoids processing overheads associated with replication at the source and the bandwidth overheads due to sending duplicated packets on the same link. For example, for a ten (10) parties Video Conference a nine (9) times lower bandwidth may be needed, if all belong to the same branch of a tree.

Multicasting is more efficient in terms of network and receiver resources than broadcasting, but it requires additional mechanisms for group maintenance that are not needed for broadcasting. In both multicasting and broadcasting, communication is normally unidirectional, from the sender to all receivers. Since receivers may be numerous, it is hard for the sender to establish reverse communication channels with each and every one of them. While in the forward direction (from the sender) the network makes sure that data are only sent once on each link, in the reverse direction the data returned by different senders cannot be easily aggregated.

### **2.6.1 Multicasting in UMTS Networks prior to MBMS**

Two services for transmitting data from a single source to several destinations were defined prior to Multimedia Broadcast Multicast Service (MBMS): the Cell Broadcast Service

(CBS) and the IP multicast service. Both have limitations with respect to their operation in CDMA based systems.

The CBS service is analogous to the Teletex service offered on television, in that like Teletex, it permits a number of unacknowledged general CBS messages to be broadcast to all receivers within a particular region. CBS allows low bit-rate data to be transmitted to all subscribers in a set of given cells over a shared broadcast channel and without any QoS.

The IP Multicast defines an architecture that allows IP applications to send data to a set of recipients (a multicast group) specified by a single IP address. The IP multicast traffic can be received by mobile subscribers already, however, no optimised transport solution exists.

In the initial UMTS multicast design [26], 3GPP has chosen to terminate the IP multicast routing protocol in the GGSN. With this design, GGSN serves as a Rendezvous Point Router<sup>3</sup>. Also, GGSN serves as an IGMP<sup>4</sup> (Internet Group Management Protocol [72]) designated router and performs IGMP signalling on point-to-point packet-data channels. IGMP signalling is performed in the network user plane (it is seen as data traffic for the UMTS network). Multicast data is forwarded to the UMTS terminal on point-to-point packet-data channels (unicast distribution). The GGSN manufacturer can choose which IP multicast routing protocol to support. Only the UMTS terminal and the GGSN are multicast aware in this design. This architecture allows the network to treat multicast traffic in the same manner as unicast traffic (see Figure 8).

---

<sup>3</sup> Core or Rendezvous Point Router is the router on which the designated routers of the interested hosts send an IGMP Join message to join the multicast group. Then, a multicast distribution tree is constructed with the core router (rendezvous point) as the root of the tree.

<sup>4</sup> IGMP provides the means for a host to inform its attached router (designated router) that an application running on a host wants to join a specific multicast group.



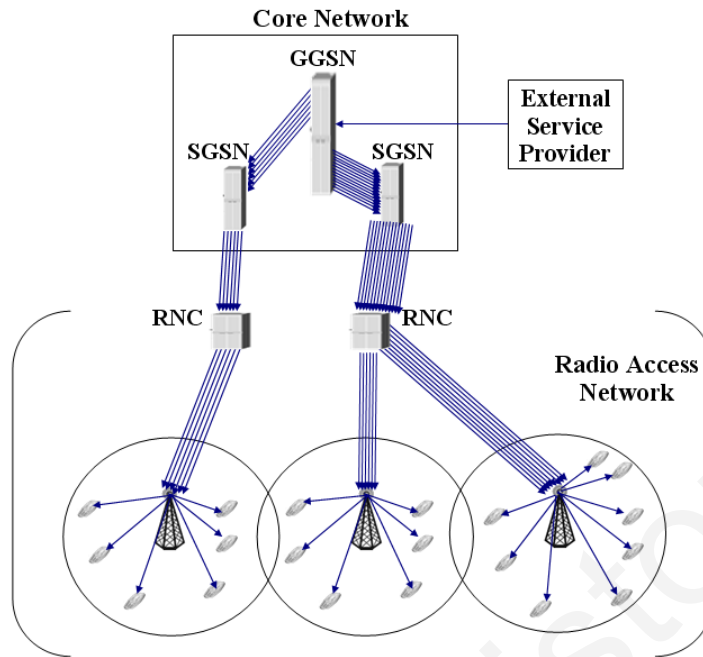

Figure 8 Multicasting in UMTS Networks prior to MBMS

To send/receive multicast data, the terminal must perform first a “GPRS attach”. Next the terminal must establish a packet-data channel with the GGSN. The UMTS terminal is now part of the IGMP environment, and can join and leave multicast groups using normal IGMP signalling. Finally the terminal must establish one or more packet-data channels (Packet Data Protocol (PDP) context activation) for the multicast data flows.

This multicast architecture reduces the load on a wireless source (see Figure 8). The source only needs to send one copy of the multicast data to the GGSN. It will be the GGSN’s job to replicate and forward the packet on to the multicast distribution tree. The drawback of this design is that the UMTS multicast source does not receive any information from multicast members. Thus even if the multicast group does not have any members, the source continues transmitting its multicast data to the GGSN. The source is not aware of the empty state of the multicast group. A modified signalling connection between the GGSN and the source can avoid this situation. This architecture also imposes a high strain on the GGSN. The GGSN already has the responsibility for many complex mechanisms, thus it is important to avoid turning the GGSN into the UMTS network’s bottleneck.

Furthermore, the multicast architecture requires multicast routing protocol and IGMP support from the GGSN. Note that the IGMP protocol's interaction is only limited to a host and its attached multicast router. So, another protocol is clearly required to coordinate the multicast routers, including the attached routers, throughout the Internet, so these multicast datagrams are routed to their final destination. The later functionality is accomplished by the network-layer Multicast Routing Protocols [73][74]. This functionality includes identification and replication of multicast data. A limiting factor in the GGSN is the number of concurrent active PDP contexts. Multicast termination in GGSN requires one PDP context dedicated to IGMP signalling for each multicast member. One or more PDP contexts are also required for each multicast member to receive the multicast data. This means that multicast traffic will in many cases require more PDP context resources than unicast distribution of the same data. In short terms, this multicast architecture enables a UMTS terminal to participate in multicast sessions. The drawback is that it (in most cases) requires more network resources than unicast distribution of the same data. Moreover, due to the fact that GGSN serves as a Designated Router, detailed membership information must be stored in the GGSN for the UMTS Terminals. This architecture might work efficiently when the number of the users requesting to join the multicast group is low. But imagine the capacity and processing requirements in the core and the radio network when a great number of users (e.g., 10000 users) request the same MBMS service. The network may then collapse.

With these shortcomings in mind, the 3GPP has defined a new service, the MBMS, that decreases the amount of data within the network and uses resources more efficiently. It aims to offer an efficient way to transmit data from single source to multiple destinations over the radio network. MBMS is transparent to end users (they have the same experience as with Point-to-Point (P-t-P) connections) but saves resources on the mobile operator side with an emphasis on the optimization of the radio access.

## 2.6.2 Multimedia Broadcast Multicast Service (MBMS)

MBMS [1][2] is a Point-to-Multipoint service in which the same data is transmitted from a single source entity to multiple recipients allowing the core- and radio- network resources to be shared. MBMS is a new service introduced in 3GPP UMTS Release 6 specifications. There are two modes of operation in MBMS:

- *Broadcast mode*, is a unidirectional Point-to-Multipoint transmission of multimedia data (e.g., text, audio, picture, video) from a single source entity to all users in a broadcast service area. No subscription is needed. The already existing Cell Broadcast Service (CBS) is intended for messaging only. The broadcast mode is expected to be a service without charging and there are no specific activation requirements for this mode.
- *Multicast mode*, allows the unidirectional Point-to-Multipoint transmission of multimedia data (e.g. text, audio, picture, video) from a single source point to a multicast group in a multicast service area. Unlike the broadcast mode, the multicast mode generally requires a subscription to the multicast group and then the user joining the corresponding multicast group. End users need to monitor service announcements regarding service availability, and then they can join the currently active service. From the network point of view, the same content can be provided in a Point-to-Point fashion if there are not enough users to justify the high power transmission of the Point-to-Multipoint channel. Unlike the broadcast mode, it is expected that charging data for the end user will be generated for this mode.

Reception of an MBMS multicast service is enabled by certain procedures that are illustrated in Figure 9. The subscription, joining and leaving phases are performed individually per user. The other phases are performed for a service, i.e., for all users interested in the related service. The sequence of phases may repeat, e.g., depending on the need to transfer data. Also subscription, joining, leaving, service announcement as well as MBMS notification may run in parallel to other phases.

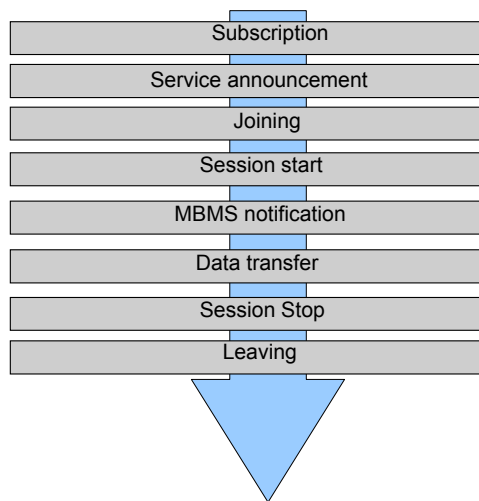

*Figure 9 Phases of MBMS Multicast service provision*

**Subscription:** Establishes the relationship between the user and the service provider, which allows the user to receive the related MBMS multicast service. Service subscription is the agreement of a user to receive service(s) offered by the operator.

**Service announcement:** MBMS service announcement/discovery mechanisms allow users to request or be informed about the range of MBMS services available. This includes operator specific MBMS services as well as services from content providers outside of the PLMN. Service announcement is used to distribute to users information about the service, parameters required for service activation (e.g. IP multicast address) and possibly other service related parameters (e.g. service start time).

**Joining:** Joining is the process by which a subscriber becomes a member of a multicast group, i.e. the user indicates to the network that he/she is willing to receive multicast mode data of a specific service.

**Session Start:** Session start is the point at which the Broadcast Multicast Service Centre (BMSC) is ready to send data. This can be identified with the start of a "Multicast session". Session start occurs independently of activation (i.e., joining) of the service by the user (a given user may activate the service before or after session start). Session start is the trigger for network resources establishment for MBMS data transfer.

**MBMS notification:** Informs the UEs about forthcoming (and potentially about ongoing) multicast data transfer.

**Data transfer:** Is the phase when MBMS data are transferred to the UEs. Arrival of the first packet at the GGSN may coincide with session start.

**Session Stop:** Is the point at which the BMSC determines that there will be no more data to send for some period of time – this period being long enough to justify removal of network resources associated with the session. At session stop, the network resources are released.

**Leaving:** Leaving is the process by which a subscriber leaves (stops being a member of) a multicast group, i.e. the user no longer wants to receive multicast mode data of a specific service.

Some applications for MBMS could be the following:

- **News clips:** For example main news, sport results, economics etc., which can be realized by text distribution, picture delivery or video streaming.
- **Audio stream:** For example music clips and important voice notifications
- **Localized services:** For example local tourist information showing the most important places, restaurants etc, as video streaming.
- **Combined audio and picture/ video clip services:** For example advertisements, interactive television voting (beauty contents) and real time betting.
- **Video distribution services,** either via streaming, carousel or downloads methods.
- **Content distribution in general:** For example, downloading individual files, http, video, audio or combination of both. This can be used, for example, for software updates of User Equipments.

### 2.6.3 MBMS system architecture

MBMS system architecture enables the efficient usage of radio-network and core-network resources, with an emphasis on radio interface efficiency. In a UMTS network, bandwidth is a limited resource, and in some applications when multiple users have to receive the same data at the same time, it would benefit the network to transmit the data only once over a particular

link. All terminals that subscribe to the MBMS service listen simultaneously on the same frequency and time slot.

MBMS system (see Figure 10) is realised by enhancing the UE, UTRAN, SGSN and GGSN with additional functionalities and the addition of one more component, the Broadcast Multicast Service Centre (BMSC). The BMSC is the MBMS data source. MBMS data is scheduled in the BMSC. It offers interfaces over which content provider can request data delivery to users.

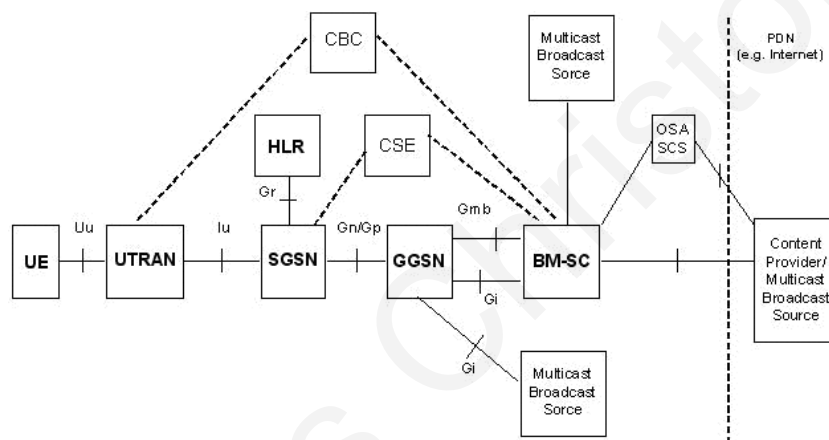

Figure 10 MBMS System Architecture

#### 2.6.4 MBMS Distribution Tree Construction

When the multicast mode is used, the mobile network has to handle group communication issues on the network layer and below. Since only one flow of packets for each group is sent through the network and it is replicated at each branch, the network needs to know about the group members for each branch. Traffic shall only be forwarded on branches leading to group members. An important aspect of the membership handling is keeping track of moving members. Members change their point of attachment to the network and hence network branches and serving nodes. To ensure that all members are being reached, the membership information in each node must be up to date, when the user plane is established. Group membership information is maintained in each intermediate node on the transmission path.

The information is stored in MBMS specific contexts called MBMS Bearer Contexts (Called MBMS Service Context in RNC) and MBMS UE Context. Also the UE needs to store membership and lower layer specific information locally. During the UE's mobility from one cell to another, the contents in these MBMS specific contexts have to be updated.

MBMS data will be distributed to multiple users through an MBMS distribution tree that can go through many RNCs, many SGSNs and one or more GGSNs. Furthermore some bearer resources may be shared between many users accessing the same MBMS bearer service in order to save resources. As a result, each branch of the MBMS distribution tree shall be established with the same QoS. When a branch of the MBMS distribution tree has been created, it is not possible for another branch (e.g., due to arrival of a new UE or change of location of a UE with removal of a branch and addition of a new one) to impact the QoS of already established branches. There is no QoS value negotiation between UMTS network elements. This implies that some branches may not be established if QoS requirements cannot be accepted by the concerned network node. Also in the Radio Access Network (RAN) there is no QoS (re-)negotiation feature for the MBMS bearer service.

After the announcement of the MBMS service by the BMSC, the UE must initiate a Join procedure in order to register itself to the MBMS service group. When this procedure is finished each node in the Core Network has a list of downstream nodes to know where it should forward data. Therefore, the BMSC list contains all GGSNs to which data should be forwarded, the GGSN list contains all SGSNs to which data should be forwarded and the SGSNs list contains all RNCs to which data should be forwarded. Each RNC controlling one or several cells within an MBMS service area, maintains an MBMS Service Context for each MBMS Bearer Service. Each MBMS Service Context is associated with a unique MBMS Service ID. This MBMS Service ID corresponds to the TMGI (Temporary Mobile Group Identity).

The MBMS Service Context in the RNC contains a list of PMM\_Connected mode UEs only (No RRC Idle UEs are contained in the MBMS Service Context), which are present in a

cell controlled by the RNC and have activated the same MBMS bearer service. When the MBMS content is ready to be distributed the MBMS Session Start procedure is initiated, which is the request to activate all necessary bearer resources in the Core Network and the UTRAN. In the UTRAN, the RNC based on information in its MBMS Service Context selects on a per cell basis the appropriate Radio Bearer type that would consume less radio resources, either Point-to-Point or Point-to-Multipoint Radio Bearer, for MBMS transmission in each cell. The terms Point-to-Point and Point-to-Multipoint can be interpreted in the following way:

- *Point-to-Point Radio Bearer* will be a Dedicated Channel (DCH) that is bi-directional with Inner and Outer loop power control. DCH is a Point-to-Point channel; hence it suffers from the inefficiencies of requiring multiple DCH to carry common data to a group of receivers. However, DCH can employ fast closed-loop power control and soft handover mechanisms, to achieve a highly reliable channel. DCH also consists of an uplink channel, which is used to feedback power control information among other control or data signals to the cellular network.
- *Point-to-Multipoint Radio Bearer* will use common channel in the downlink only. The common transport channel that has been proposed by the 3GPP is the Forward Access Channel (FACH) and it aims to overcome network congestion when a large number of users request the same content. Even with a large number of multicast receivers, only one FACH is required for the transmission of the MBMS service, with no load on the uplink connections. Data transmitted on the FACH cannot be reliably received by the multicast receivers as there is no channel for the feedback of received quality back to the network. Also fast power control cannot be applied on FACH channel.

In order to clarify why two types of transmission modes are used let consider the following:



- The Forward Access Channel (FACH) can be shared by several UEs. Power control is NOT applied with this channel thus a fixed amount of transmission power (capacity) is allocated and that much in order to cover the whole cell's area.
- On the other hand the Dedicated Channel (DCH) is dedicated only to one UE. With this channel power control is applied and thus the amount of power (capacity) allocated is dynamically adjusted at a level which aims to ensure the QoS level requested without causing additional interference (minimum power required).

It is obvious that as FACH needs to be received by all UEs in the cell, also those near the cell's border, it requires more radio resources (power) than one Dedicated Channel (DCH). Thus, sometimes few Dedicated Channels (DCHs) might outperform the use of one FACH in terms of radio resource efficiency. On the other hand, if the number of users and their distance from the Base Station is increasing it is more efficient to use a FACH. The characteristics of FACH and DCH channels are further described in section 2.6.5. The gains that can be achieved with MBMS, compared to the initial approach used for multicasting in UMTS Networks, on the load introduced both on the core and radio network, are illustrated in Figure 11.

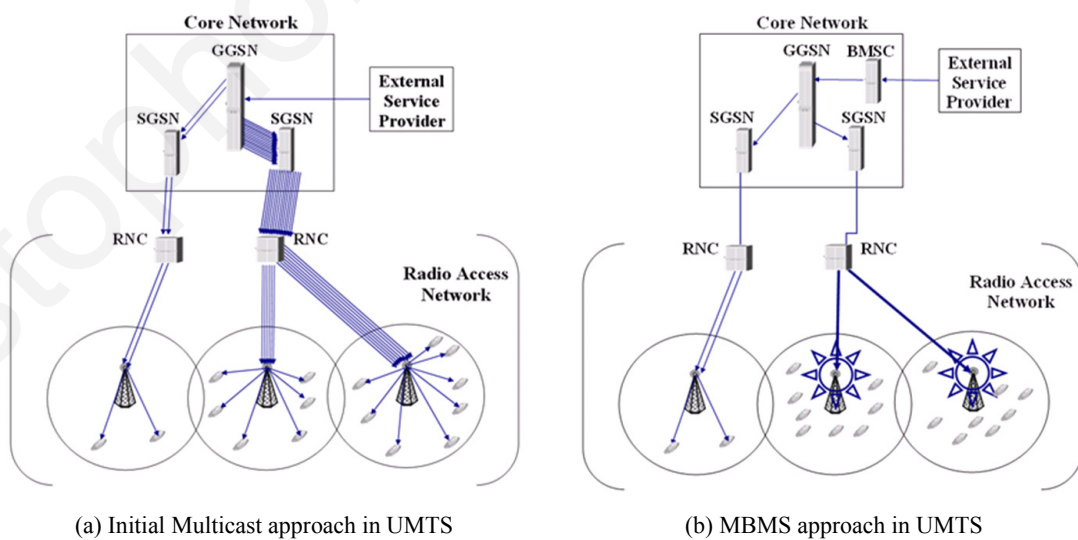

Figure 11 Initial Multicast approach in UMTS Vs MBMS approach

### 2.6.5 Characteristics of FACH and DCH channels

In this section we analyse the characteristics of the FACH and DCH channels that take part in the MBMS service provisioning. This will also assist in clarifying the main challenges of our designs and the approaches we adopt to address them and achieve the performance goal (see Chapter 3 and Chapter 4).

The FACH can be shared by several users without requiring additional radio resources (i.e. **FACH offers capacity benefits**). Thus, MBMS users receiving an MBMS service and handing over into a P-t-M transmission mode cell will not have to request additional resources since they can tune to the FACH already established in the cell. However, **fast power control is not applied on FACH**. Thus, a fixed amount of transmission power has to be allocated to this channel (irrespective of the number of the UEs that are receiving it or their location in the cell at any particular point in time), typically at a rather high power level, such that the requested QoS is guaranteed right up to the coverage limit of the selected coverage area. Since the FACH's transmission power is fixed, its **coverage range is bounded**. Thus leaving its coverage area results in progressive signal strength degradation and finally total 'collapse' of the throughput.

On the other hand, the DCH is dedicated only to one user and allows the use of **fast power control**. Fast power control is a crucial aspect in UMTS because it **improves link performance and enhances downlink capacity**, by reducing the average required transmission power and interference to other users. The coverage of the DCH is flexible as it can be increased at the expense of more power; **the greater the distance of the user from the Node-B, the more the (exponential) increase in the transmission power required**.

### 2.6.6 MBMS Counting Mechanism

Before making the decision to use either P-t-P or P-t-M transmission mode to a group of users in a cell (see [2]) the resource manager must have some indication of how many users (UEs) are in the cell requiring this multicast service. Knowledge of the exact number of UEs belonging to a particular multicast group at any instant in time will always be uncertain. This

is due to a number of factors, for example, users changing cells, switching off, being in idle mode or unsubscribing from the service. Consequently, there must be some mechanism or procedure that attempts to do this. It is called “MBMS Counting” in 3GPP and is used to determine the optimum transmission mechanism for a given service.

Each RNC, controlling one or several cells within an MBMS service area, maintains an MBMS Service Context for each MBMS service. This MBMS Service Context contains a list of connected mode UEs which have activated the MBMS services. RNCs are reliant on the SGSN to inform them that a UE has activated MBMS service(s). However the MBMS Service Context in the RNC does not contain information about UEs in RRC Idle mode. Therefore, to gain a better estimate of the total number of users interested in a given service, the UTRAN uses an MBMS counting function, which has a mechanism to prompt users to become RRC connected. This procedure is only applicable for UEs in idle mode. For every UE brought to RRC connected state for the purpose of counting, UTRAN will initiate the Connection establishment procedure and will obtain from CN the set of MBMS services these users have joined.

In addition to counting, the number of subscribers that need to be maintained in RRC connected mode or for which the RNC releases their connection, is also an RRM issue. For a given MBMS service, the counting indication in the notification may be switched on and off, on per-cell basis.

During a P-t-M transmission mode, the UTRAN may perform re-counting to verify if this mode is still the optimal transfer mode. It will rely on the same scheduling of the MBMS Point-to-Multipoint Control Channel (MCCH; see APPENDIX B) information. Whether it is counting or re-counting, the UTRAN is only able to count the UEs interested in the MBMS service using UE linking from the Core Network (more specifically from the SGSN). In the case that no UE is counted then UTRAN may decide not to provide any Radio Bearer (RB) for the service in that cell.

### 2.6.6.1 RRM Counting Algorithm using Probability Factors

Depending on the type of service, cell, and traffic conditions the RRM will decide per MBMS service and cell, some threshold value for the number of users required to transmit in P-t-M transmission mode. The UTRAN will know the number of MBMS service users in Cell\_FACH and Cell\_DCH states and if this is larger than the threshold number then P-t-M transmission can go ahead provided other resource parameters are met. However it is more than likely that there will be a large number of UEs in idle mode (or URA\_PCH mode) and hence will be unknown to the UTRAN. In this case the RNC sends the first Probability Factor (PF), which is a number less than 1, to the cell in order to get some idle UEs (or URA\_PCH UEs) to make RRC connection request (or Cell Update). If the counted users are not large enough to cross the counting threshold, another PF is sent out to count more users. The procedure continues until the decision is made or PF=1 is reached.

Let's consider the first round of the algorithm in more detail: If  $N$  is the number of MBMS service UEs in idle mode and the probability factor is  $PF_1$  then  $N * PF_1$  will be the statistical number of users that make an RRC connection. This requires a function in all MBMS enabled UEs that use this PF to generate a Boolean true or false, which will determine if they will make an RRC connection. However the function is seeded with a random number such that statistically only a certain number of UE's will calculate true. This number can be increased by increasing the probability factor PF and in the case where  $PF = 1$  they will all make an RRC connection. For example, if there are 10000 MBMS service users and  $PF_1 = 0.001$  we would expect that 10 users would make an RRC connection. The reason that the algorithm must proceed in steps is so that the number, which perform RRC connection request, will not overload the RACH. There are 15 slots and around 12 RACH sub-channels, so 10 to 18 requests would seem appropriate at any one time that is not more than 10% loading. So the RRM algorithm must choose the first PF such that a reasonable number of UEs attempt an RRC connection but not too many to overload the RACH. Furthermore it must continue choosing new PFs based perhaps on the previous RRC connection responses in

the least number of rounds possible. The PF will be coded as a number of bits perhaps 3, 4 or 5 such that PF numbers can be chosen with granularity sufficient for the counting algorithm to complete in a minimum of steps.

## Chapter 3

### MBMS Handover Control

#### 3.1 Introduction

According to the MBMS specifications currently defined by the 3GPP [1], MBMS bearer services can be provided within a cell either by Point-to-Multipoint (P-t-M) or by Point-to-Point (P-t-P) transmission mode. With the P-t-M transmission mode one Forward Access Channel (FACH) is established, with fixed and adequate power to cover the whole cell's coverage area, and shared by all the UEs within (including those near the cell's edge). On the other hand, with the P-t-P transmission mode one Dedicated Channel (DCH) is established for each UE in the cell. As a result of the two transmission modes used, the mobile users that are on the move and receive an MBMS service may have to deal with the following (four) types of handovers (see Figure 12) when crossing the cell's edge:

- 1) From P-t-P (DCH) to P-t-P (DCH) transmission mode cell
- 2) From P-t-M (FACH) to P-t-M (FACH) transmission mode cell
- 3) From P-t-M (FACH) to P-t-P (DCH) transmission mode cell
- 4) From P-t-P (DCH) to P-t-M (FACH) transmission mode cell

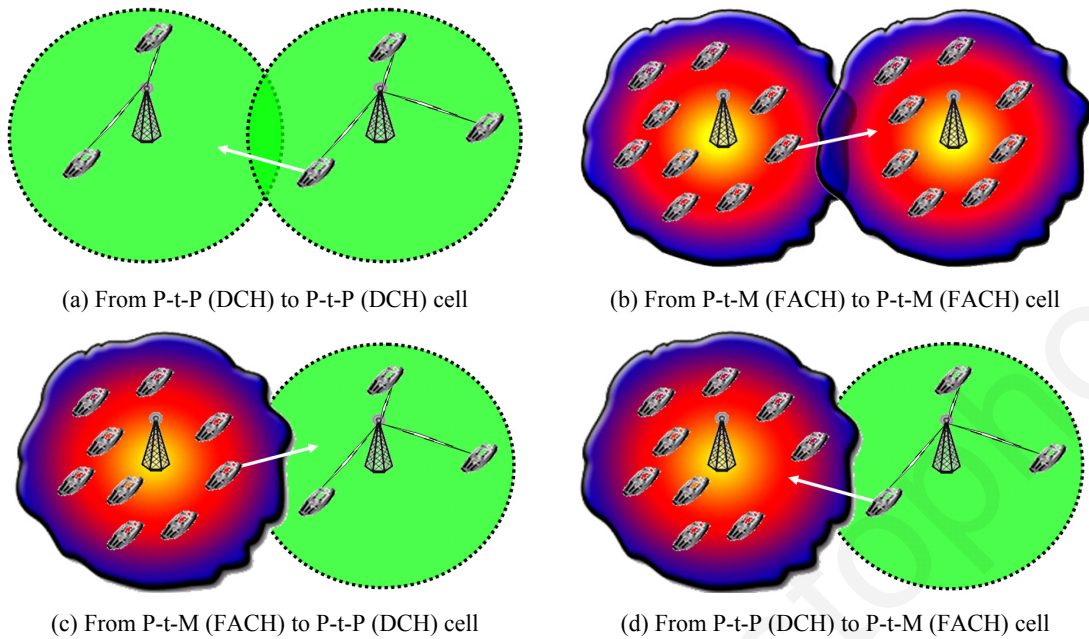

Figure 12 Types of inter-cell handovers introduced with MBMS

In contrast with the first and second types of handovers, which have been extensively researched, the third and the fourth types of handovers (i.e., Handover types 3 and 4 - From FACH to DCH and vice versa) have not been explored yet and a specific handover approach for efficiently executing these types of handovers has not been proposed in the open literature neither standardized by 3GPP. Thus, during our research on MBMS handover control, we focused on these two types of handovers and propose a new MBMS handover control algorithm for facilitating their efficient execution. Throughout the description we will refer to these two types of handovers as “MBMS Handovers”, since they are introduced only with MBMS services.

During our first attempt to formulate the MBMS handover algorithm [34]-[36], in order to illustrate our ideas and simplify our analysis, we assumed non-fading channels (i.e., strong Line of Sight between the User Equipment and the Base Station). Future extensions of this work [37][38] relaxed this assumption, considering Non-Line of Sight transmissions. With the aforementioned solutions, achieving efficient MBMS handover execution came at the expense of adding some processing complexity in the User Equipment (UE) in order to estimate some

parameters which are vital for efficient handover triggering. Also a GPS receiver was required in the Terminal. Thus, our later work performed on this issue [39][40], optimized previous work and eliminated the complexity and the GPS requirement in the Terminal.

This Chapter is organized as follows: In section 3.2 we discuss related work on MBMS handover control. In section 3.3 we elaborate on the need for a new handover control approach for “MBMS Handovers” by highlighting the inefficiencies that can occur if the current 3GPP specified hard handover approach, as described in [8] and [9], is applied for executing an MBMS Handover. In section 3.4 the main challenges of our proposed MBMS handover control scheme are discussed, and the problem formulation is described in section 3.5. In section 3.6 we describe our proposed MBMS handover approach and analyze the processing complexity, the memory requirements, and signalling overhead introduced. In section 3.7 we present the performance evaluation and finally in section 3.8 we provide some concluding remarks.

## **3.2 Related Work**

Authors in some related papers [27]-[30] have studied issues concerning the efficient execution of handover between dedicated resources (Handover type 1 - from DCH to DCH) using soft handover. With soft handover, a UE can simultaneously receive signals from two or more Base Stations that are transmitting the same bit stream (using different transmission codes) on the different physical channels in the same frequency bandwidth. With this approach, the receiver can combine the received signals (macro-diversity combining) in such a way that the bit stream is decoded much more reliably than if only one Base Station were transmitting to the UE, giving an additional macro-diversity gain against fast fading by reducing the required  $E_b/N_0$  relative to a single radio link without a performance loss. The soft handover algorithm is described and standardized by the 3GPP in [8] and [9].

Data transmission on FACH (which is transmitted using Secondary Common Control Physical Channel (S-CCPCH)) is especially sensitive to the channel fading, since fast power



control cannot be applied on S-CCPCH. Thus, in order to improve the transmission efficiency over S-CCPCH at cells' edge and achieve efficient handovers between P-t-M transmission mode cells (i.e., Handover type 2 – From FACH to FACH), 3GPP release 6 specifications for MBMS [2] introduced two macro diversity schemes, namely the soft and selective combining. These macro-diversity schemes have been studied in [13][31][32][33] for both microcell and macrocell environments. In case of selective combining, the UE receives and simultaneously decodes packets from radio links transmitted from different cells. After the reception and decoding, the received packet is handled at the Radio Link Control (RLC) layer where Cyclic Redundancy Check (CRC) is performed. Based on the CRC, the first packet which is received correctly is chosen. If any of the sources cannot provide error-free packet then the packet is lost. Unlike selective combining, in case of soft combining the UE collects all the packets from the different cells, aligned in time and finally combined in the physical layer. After the combining is done, the receiver decodes the (combined) packet and checks whether the packet was received correctly or not. When soft combining is used, it is possible to increase the overall SNIR (Signal to Noise plus Interference Ratio) at the receiver and thus the possibility to receive the packet correctly is increased even though all of the MBMS transmissions from the different cells could somehow be faulty.

On the other hand, questions related to the efficient execution of handovers between dedicated (DCH) and common (FACH) channels (i.e., Handover types 3 and 4 - From FACH to DCH and vice versa) have not been explored yet and a handover approach for efficiently executing these types of handovers has not been proposed neither standardized by 3GPP. To the best of our knowledge, our work in [34]-[40] was the first attempt to formulate a handover scheme that efficiently addresses this issue. Due to the fact that macro-diversity (Soft Handover) cannot be applied between different kinds of channels (i.e., between FACH and DCH), these “MBMS Handovers” are handled as hard handover cases. Hard handover means that all the old radio links in the UE are removed before the new radio links with the Target cell are established.

According to the current 3GPP specified hard handover approach (as described in [8] and [9]), the mobile station performs a handover when the Common Pilot Channel (CPICH)  $E_c/N_0$  signal quality of the Target cell exceeds the CPICH  $E_c/N_0$  signal quality of the serving cell within a predefined threshold value ( $AS\_Rep\_Hyst$  - Replacement Hysteresis Threshold). Later works ([41] and [42]) further improved the performance by having a more dynamic setting of the above threshold.

More specifically, in [41], performance was further improved by having a more dynamic setting of the above measurements where there was an adjustment according to Best Pilot Strength. For this adjustment, the adaptive UMTS handover control algorithm considers the influence of downlink interference. The increase of downlink interference reduces the strength of individual aggregate  $E_c/N_0$  and degrades the connection quality. So the algorithm changes the values of handover parameters like reporting range, hysteresis, and replacement hysteresis to set stringent handover add threshold and drop threshold under proper situation to avoid excessive handover. The stringent add/drop thresholds can decrease downlink interference by avoiding unnecessary handover and provide better connection quality.

In [42] an adaptive handover decision scheme based on the mobility estimated from signal strength measurement is developed. The handover mobility factor is proposed according to the movement of user in the handover region. More specifically, the mobility factor increases as a speed or a distance between the UE and a serving cell increases, so the mobility factor can be used as the information on directions as well as the speed of a UE at cell's edge. To avoid ping-pong handover and to enhance system performance, triggering time of handover execution is considered as adaptive controlling factor. Three rules are proposed in order to implement the specific handover algorithm, namely the fast adding decision, the fast dropping decision and finally the adaptive time delay for triggering a handover execution.

All the aforementioned approaches were implemented for legacy unicast UMTS services concerning only the characteristics of the DCH (which offers fast power control) and used the same approach for triggering the handover; the handover triggering decision is based on a

comparison between the CPICH signal quality received from the Base Stations taking part in the handover procedure. However, a vital aspect for achieving efficient MBMS handovers' execution lies in the consideration of the FACH capacity benefits and its bounded coverage characteristic (see section 2.6.5), a feature not considered by any of the aforementioned approaches.

### **3.3 Motivation for a new MBMS Handover control approach**

In this section, the need for a new approach for MBMS handovers' execution is discussed.

Considering the characteristics of the FACH and DCH channels, analysed in section 2.6.5, it is obvious that in order to guarantee the required QoS throughout the handover process and reduce the total amount of downlink power consumption in the P-t-P transmission mode cells to the least possible, the MBMS handover should be executed (switch from FACH to DCH, or vice versa) as close to the P-t-P BS as possible but not outside of the FACH's supported coverage area of the P-t-M transmission mode cell. Executing the MBMS handover anywhere else will mean either underutilization of the FACH's capacity benefits or degradation on the MBMS service QoS.

The current 3GPP specified hard handover control approach was initially adopted to execute an "MBMS Handover". This resulted either in capacity or QoS inefficiencies, as discussed below. The scenario used for quantifying the capacity and QoS inefficiencies that can occur when the current 3GPP specified hard handover is applied is illustrated in Figure 13. In this scenario a UE is moving with a speed of 5 Km/h from a P-t-M (FACH) towards a P-t-P (DCH) transmission mode cell and receiving an MBMS streaming video of 64 Kbits/sec. The simulation parameters used are illustrated in Table 1.

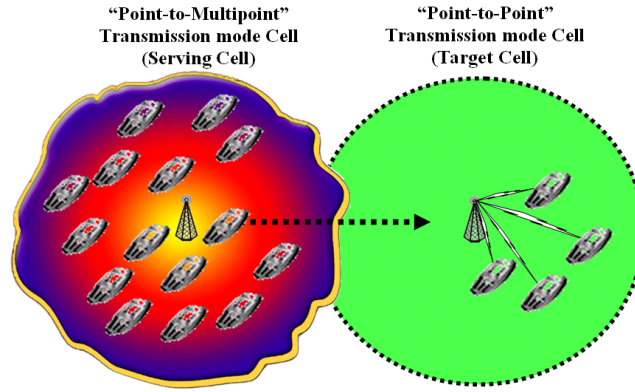

Figure 13 Scenario - Motivation for a new MBMS Handover control approach

Table 1 Simulation Parameters used – Motivation for a new MBMS Handover control approach

Simulation Parameter	Value
Propagation environment	Pedestrian Outdoor
Cell radius	1000 meters
Node-B spacing	~1800 meters (200 meters overlap)
Node-B Antenna type	Omnidirectional
Shadow fading standard deviation	log-normal of 10 dB
Transmission Time Interval (TTI)	20 ms (as suggested in [43])
Channel coding	Convolutional 1/3 coding rate
Downlink Other-cell Interference factor	1.78
Thermal Noise power spectral density	-174 dBm
Orthogonality factor	0.5

Two instances of the same scenario have been simulated using the UMTS model of OPNET modeller 11.0.A. In the first instance, the target cell (i.e. the P-t-P transmission mode cell) has been configured to be high loaded (i.e., high noise (No) in the cell) while in the second instance to be low loaded (i.e., low noise (No) in the cell). For the simulation, the current 3GPP specified hard handover control approach was applied to execute the MBMS handover using an AS\_Rep\_Hyst of +1dB. Note that a variety of other AS\_Rep\_Hyst threshold values (from -3dB to +3dB) have been also tested, resulting in similar inefficiencies to those described below.

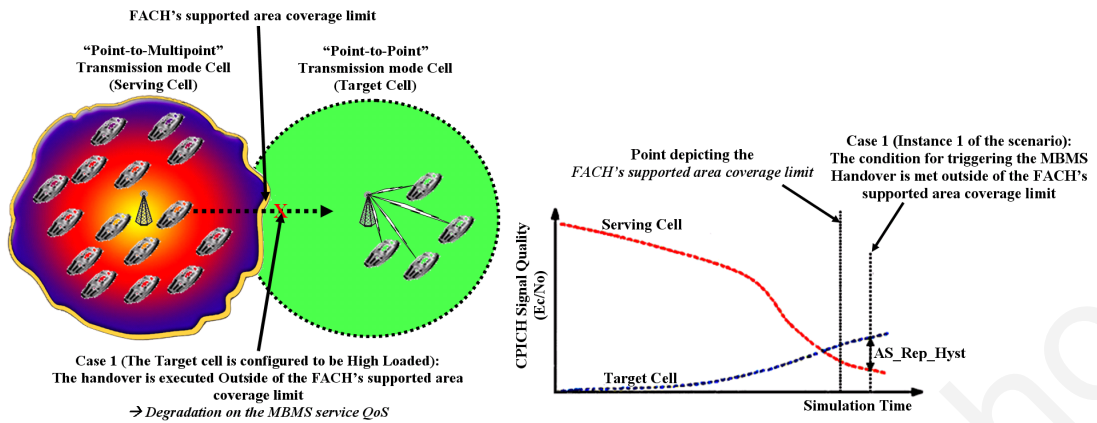

Figure 14 MBMS Handover - Instance 1 (High noise in the Target cell)

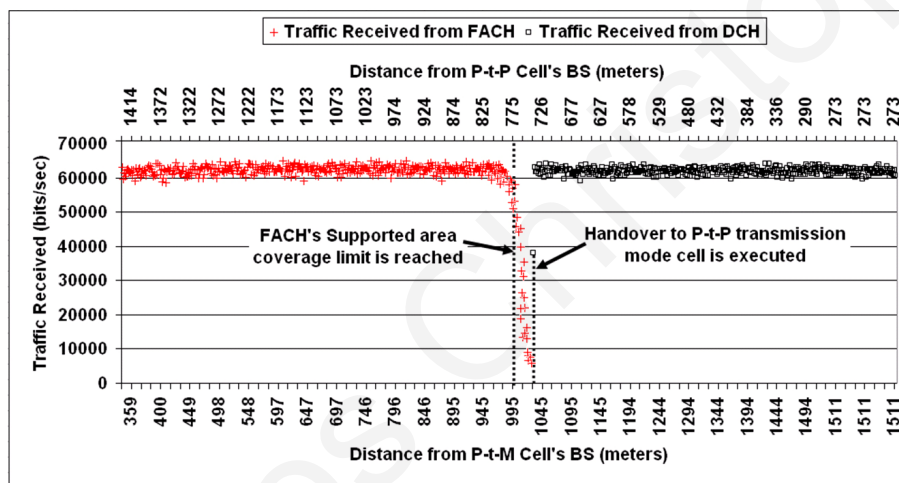

Figure 15 3GPP handover control approach - QoS inefficiency occurred

Adopting the current 3GPP specified hard handover approach in Instance 1 (i.e., Case 1 illustrated in Figure 14), where the noise in the target cell is high, results in the execution of the MBMS handover outside of the FACH's supported area coverage limit. This is caused due to the high degradation that the high noise ( $N_o$ ) present in the target cell causes on its received CPICH  $E_c/N_o$  signal quality, forcing the UE to get closer to the P-t-P BS before the handover condition triggering is met. Since the transmission power allocated for FACH is at a level aimed to ensure the requested QoS only throughout the coverage of the P-t-M transmission mode cell (i.e., in this case 1000 meters from the P-t-M transmission mode cell's BS), once outside the FACH's supported area, the signal strength of the FACH starts degrading, and becomes inadequate for the UE to decode the packets correctly. This, results initially in some

packet loss and later in almost total collapse of the throughput (see Figure 15). The QoS is restored when the handover's condition is met and the UE is handed over to the P-t-P transmission mode cell.

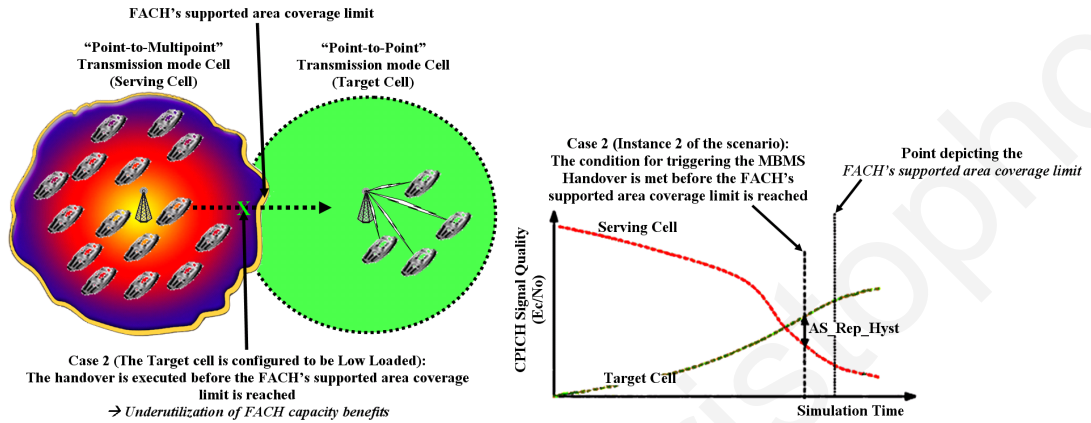

Figure 16 MBMS Handover - Instance 2 (Low noise in the Target cell)

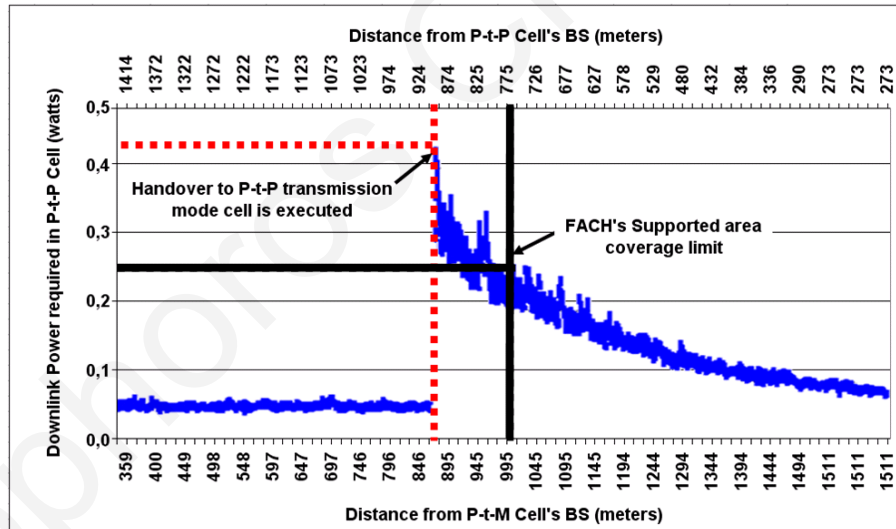

Figure 17 3GPP handover control approach - Capacity inefficiency occurred

On the other hand, adopting the current 3GPP specified hard handover approach in Instance 2 (i.e., Case 2 illustrated in Figure 16), where the noise in the P-t-P transmission mode cell is low, results in the execution of the MBMS handover before the UE reaches the FACH supported area coverage limit. In this case the UE will not experience any degradation on the MBMS service QoS, since it is still inside the FACH guaranteed coverage area.

However, since FACH can guarantee the requested QoS up to the coverage limit of the cell (that is ~1000 meters from the P-t-M transmission mode cell's BS), executing the MBMS handover before this point is reached results in inefficient use of FACH's capacity benefits, since the UE could continue receiving the MBMS service, without QoS deterioration, up until the cell's coverage limit, and thus execute the MBMS handover closer to the P-t-P transmission mode cell's BS. This could result in less power consumption (for the DCH) in the P-t-P transmission mode cell and consequently in less intra- and inter- cell interference caused. This inefficiency is highlighted in Figure 17. The red thick discontinued line shown in Figure 17 indicates the point where the MBMS handover was actually executed. As it is shown, after handover's execution, the total downlink power required in the P-t-P transmission mode cell is increased from 0.06 watts to 0.43 watts. Note that the black thick continued line shown in the same figure, indicates the point where the handover should be executed, considering that FACH can be reliably received up to the coverage limit of the P-t-M transmission mode cell. This would result in significant transmission power savings in the P-t-P transmission mode cell (allocating 0.25 watts instead of 0.43 watts, after MBMS handover's execution; i.e., 42 % less transmission power for the presented case), since the handover will be executed closer to the P-t-P transmission mode cell's BS.

The inefficiencies that can occur if the current 3GPP specified hard handover approach is applied to execute an MBMS handover (QoS degradation and inefficient use FACH's capacity benefits), highlight the reason why a specific handover control approach is essential for MBMS. It is worth mentioning that, a vital aspect for the efficient execution of these new types of MBMS handovers is the consideration of the FACH capacity benefits and its bounded coverage characteristic, a feature not considered by the current 3GPP specified hard handover control approach or any other related approach in the open literature.

### 3.4 Main challenges of the proposed design

As indicated above, in order to achieve efficient “MBMS handover” execution and avoid any QoS or capacity inefficiencies from occurring, the handover should be executed (i.e., switch from FACH to DCH or vice versa) as close to the BS of the P-t-P transmission mode cell as possible (in order to reduce DCH’s transmission power requirements) but not outside of the P-t-M transmission mode cell’s FACH supported area coverage limit (since outside of the FACH supported area a QoS degradation occurs). Thus, the optimum execution point of the handover is obviously the P-t-M transmission mode cell’s FACH supported area coverage limit.

However, achieving execution of the MBMS handover exactly on the “FACH supported area” coverage limit, is not so straightforward and also risky due to the challenges imposed by the varying motion of the user and the signal fluctuations occurring during its mobility (mostly due to the effect of fast fading). If the aforementioned are not considered, erroneous handover triggering or frequent inter-cell handovers may occur, which can degrade the QoS, the capacity, and the network performance significantly.

Therefore, the main challenges of our proposed MBMS handover control approach are to:

- **Consider the bounded coverage range of FACH**, and trigger the handover at a point that execution will be achieved exactly on the edge, or inside the FACH supported area guaranteed coverage. The aim here is to avoid any QoS degradation from occurring during the MBMS handover.
- **Consider the capacity benefits that FACH can offer**, and trigger the handover at a point that execution will be achieved as close to the FACH supported area coverage limit as possible. The aim here is to have the UEs stay tuned to the FACH as long as its signal strength is adequate for receiving the MBMS service with the required QoS. The main idea here is to take full advantage of the resources already allocated for FACH in the P-t-M transmission mode cell and thus avoid allocating extra resources



in the P-t-P transmission mode cell for supporting the same user via DCH in an area that it can also be reliably supported using FACH.

- **Consider the transmission power requirements of a DCH** and trigger the handover at a point that execution will be achieved as close to the P-t-P transmission mode cell's BS but without affecting the QoS of the user. The aim here is to reduce as much as possible the transmission power requirements in the P-t-P transmission mode cell and thus the inter- and intra- cell interference caused.
- Consider the **varying motion of the user** as well as the **signal fluctuations occurring during its mobility** in order to lessen any possibility of an erroneous handover triggering (that might lead to any QoS degradation) or frequent inter-cell handovers (i.e., ping pong effect) from occurring.

Below we formulate our problem, and then propose a practical approach to solve it. The proposed MBMS handover control approach is described in detail in section 3.6.

### 3.5 Problem Formulation

Assume a setup (see Figure 18) of two cells and a number  $N$  of *UEs* moving freely between these cells. The one cell is using P-t-M transmission mode for the provision of the MBMS service (*Cell\_PtM*), while the other is using P-t-P transmission mode (*Cell\_PtP*). The distance between the cells' Node-Bs is assumed to be equal to  $R$ .

In *Cell\_PtM* a fixed amount  $C$  of downlink transmission power ( $P_{Cell\_PtM}$ ) is allocated (since fast power control cannot be applied on FACH), such that the requested QoS is guaranteed right up to the *Cell\_PtM*'s coverage limit. Thus,  $P_{Cell\_PtM} = C$  (where  $C$  is a constant value), irrespective of the number of UEs that are served by the *Cell\_PtM* or their position within it.

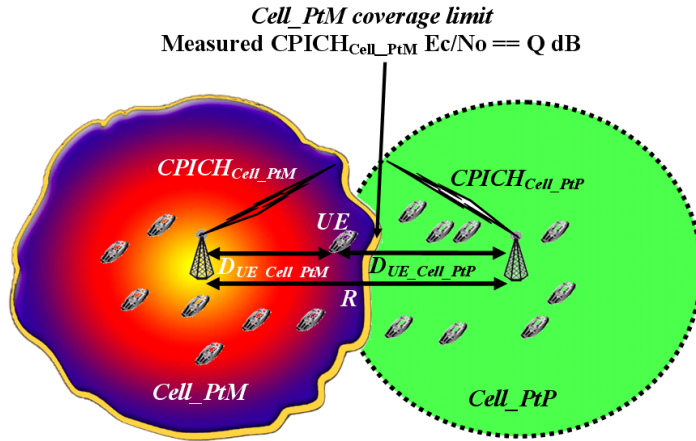

Figure 18 MBMS Handover control – Problem Formulation

Since a fixed amount of transmission power is allocated to FACH, the *Cell\_PtM*'s coverage range is bounded. Hence, outside the *Cell\_PtM*'s supported coverage area, the requested QoS cannot be reliably supported using FACH. Also, the different channel impairments<sup>5</sup> that degrade the signal quality during propagation cannot be efficiently compensated, resulting in non-homogeneous dispersion of the signal quality along the perimeter of *Cell\_PtM*.

Due to the non-homogeneous dispersion of FACH's signal quality within the *Cell\_PtM*, the distance ( $D_{UE\_Cell\_PtM}^i$ ) of a  $UE_i$ ,  $i \in \{1, 2, \dots, N\}$ , from the *Cell\_PtM*'s Node-B cannot be considered as a reliable criterion to indicate if a  $UE_i$  lies within the supported coverage area of the *Cell\_PtM*. Thus, the criterion we adopt to indicate if a  $UE_i$  lies within the *Cell\_PtM* coverage area (and thus FACH's signal quality is adequate to provide to the  $UE_i$  the required QoS), is the Common Pilot Channel (CPICH) Ec/No signal quality it receives from it ( $CPICH_{UE\_Cell\_PtM}^i$ ).

---

<sup>5</sup> The channel impairment can be due to for example the distance dependent path loss, the location dependent shadowing, multi-path fading dependent on the speed and environment of the mobile, and the interference level dependent on the serving cell activity (i.e., interference caused by other UEs within the serving cell), the cell position and neighbouring cell activity.

To ensure that a  $UE_i$  receives the MBMS service from  $Cell\_PtM$  with the required QoS, the  $UE_i$  must receive the MBMS service from the  $Cell\_PtM$  only when the following criterion (1) is satisfied:

$$CPICH_{UE\_Cell\_PtM}^i \geq Q \text{ dB} \quad i \in \{1, 2, \dots, N\} \quad (1)$$

Satisfying criterion (1) set above, is a vital concern during the MBMS handover in order to avoid any QoS degradation during the handover. The value of  $Q$  defines the minimum CPICH Ec/No signal quality that a  $UE_i$  must measure from the  $Cell\_PtM$  in order to guarantee a reliable reception of the MBMS service using FACH in the  $Cell\_PtM$ .

The  $Cell\_PtP$ , on the other hand, is supported using DCHs which allows the use of fast power control. With fast power control, the power ( $P_{UE\_Cell\_PtP}^i$ ) devoted to  $UE_i$  is increased or decreased, dynamically during the UEs' mobility, according to the instantaneous channels conditions experienced by the  $UE_i$  in the  $Cell\_PtP$ . Note that the role of the CPICH is to be used by the UE for dedicated channel quality estimation and to provide channel quality estimation reference when common channels (i.e. FACH) are involved.

For example, the shorter the distance ( $D_{UE\_Cell\_PtP}^i$ ) of a  $UE_i$  from the  $Cell\_PtP$ 's  $Node\_B$  is, the stronger the ( $CPICH_{UE\_Cell\_PtP}^i$ ) CPICH Ec/No signal quality experienced by  $UE_i$  from the  $Cell\_PtP$  (i.e. the better the channel conditions) and thus the less the  $P_{UE\_Cell\_PtP}^i$  required in the  $Cell\_PtP$  to support  $UE_i$ . On the other hand, the shorter the  $D_{UE\_Cell\_PtP}^i$  is, the greater the  $D_{UE\_Cell\_PtM}^i$ . This implies, that the stronger the  $CPICH_{UE\_Cell\_PtP}^i$ , the weaker the  $CPICH_{UE\_Cell\_PtM}^i$ , which further implies that the weaker the  $CPICH_{UE\_Cell\_PtM}^i$  is, the less the  $P_{UE\_Cell\_PtP}^i$ .

Based on the aforementioned, our objective is to determine for each  $UE_i$ , by having only as the main the input in the MBMS handover triggering decision the  $CPICH_{UE\_Cell\_PtM}^i$ , the optimal  $CPICH_{UE\_Cell\_PtM}^{i*}$  that will indicate to  $UE_i$  the exact point of the MBMS handover's execution (i.e. switch from DCH to FACH, or vice versa) so that it minimises the  $P_{UE\_Cell\_PtP}^i$ , while at the same time satisfying the criterion **(1)** set above.

Before carrying on with the problem formulation, it is worth noting that our proposed MBMS handover control approach runs in the UE. Therefore, the handover triggering decision is taken dynamically by the UE during its mobility. Note that, if other UEs are present in the system and receiving a service (either MBMS or unicast), they are indirectly considered in the  $UE_i$ 's MBMS handover triggering decision, since they appear as noise (No) in the system and thus influence the  $CPICH_{UE\_Cell\_PtM}^i$  measurements performed by the  $UE_i$ .

Since we have a dynamic environment where the UEs can move freely between the two cells, the optimal  $CPICH_{UE\_Cell\_PtM}^{i*}$  indicating the MBMS handover execution point of a  $UE_i$  is influenced by several factors including the mobility pattern  $m_i$  of the  $UE_i$  and also the possibility  $p_i$  of the  $UE_i$  to perform an erroneous handover execution due to the varying signal fluctuations occurring during its mobility, which can result in a QoS degradation or frequent inter-cell handovers.

Thus, we need to set up a dynamic optimization problem which can identify the current power requirement but also account for the mobility  $m$  of the UEs and the possibility  $p$  of an erroneous handover execution to occur and hence decide the exact point where UEs moving from one cell to the other will need to execute a mode change from P-t-M (i.e., FACH) to P-t-P (i.e., DCH) and vice versa.

Let  $P_{UE\_Cell\_PtP}^i(N, x, m_i, p_i, CPICH_{UE\_Cell\_PtM}^i)$  denote the downlink power required to be devoted to DCH in the P-t-P transmission mode cell for supporting  $UE_i$  during the MBMS handover's execution, for a given number  $N$  of UEs in the cell's and a given distribution  $x$  of

the UEs within the cell (thus introducing noise (No) to the system), a given mobility pattern  $m_i$  of the  $UE_i$ , a given possibility  $p_i$  of an erroneous handover execution and a given CPICH Ec/No signal quality ( $CPICH_{UE\_Cell\_PtM}^i$ ) measured by the  $UE_i$  from the  $Cell\_PtM$  and indicating the point of MBMS handover's execution.

The objective can thus be expressed mathematically as follows:

$$CPICH_{UE\_Cell\_PtM}^i * = \arg \min_{CPICH_{UE\_Cell\_PtM}^i} P_{UE\_Cell\_PtM}^i(N, x, m_i, p_i, CPICH_{UE\_Cell\_PtM}^i) \quad (2)$$

$$\text{subject to} \quad CPICH_{UE\_Cell\_PtM}^i \geq QdB, i \in \{1, 2, \dots, N\}$$

To formally solve the problem posed above (Eq. 2) and efficiently address the objective set, it is an extremely difficult optimization problem. Below we formulate and provide a new heuristic-based MBMS handover control algorithm, specifically designed for handovers between P-t-P and P-t-M transmission mode cells.

### 3.6 Proposed MBMS Handover control approach

Motivated by the challenges imposed in section 3.4 and the problem formulation presented above, we develop a new MBMS handover control approach to solve the problem.

By taking into consideration the FACH's capacity benefit and its bounded coverage characteristic as well as the capacity requirements of DCH (analysed in section 2.6.5), the aim of our proposed MBMS handover control approach is to guarantee the MBMS service QoS and achieve increased system capacity and performance during an MBMS handover.

This is accomplished by following a different approach than the current 3GPP specified handover control algorithm. Instead of having as the main input of the handover triggering the comparison of the CPICH Ec/No signal quality received from all the BSs that take part in the handover process, we consider only the CPICH Ec/No signal quality of the P-t-M transmission mode cell. This is a vital concern, since the main idea of our proposed MBMS

handover control approach is to reduce the transmission power required in the P-t-P transmission mode cells by taking full advantage of the capacity benefits that FACH (i.e., the P-t-M transmission mode cells) offers. The key in accomplishing this, is to find the handover triggering threshold value that will force the UE to stay tuned to FACH as long as its signal strength is adequate (in case the UE is handing over from a P-t-M to a P-t-P transmission mode cell), or tune to FACH as soon as its signal strength becomes adequate (in case the UE is handing over from a P-t-P to a P-t-M transmission mode cell), to guarantee the reception of the MBMS service with the required QoS.

By considering a number of dynamic parameters such as CPICH Ec/No Alteration Rate, Pre-Trigger Predictor, Safety Margin, Activation Hysteresis, possibility of an erroneous handover triggering to occur, which are influenced by the UE's movement, a threshold value is dynamically estimated by our algorithm running in the UE. This threshold value is compared, during the UE's mobility, with the CPICH Ec/No signal quality received only from the P-t-M transmission mode cell and aims to facilitate an efficient MBMS handover triggering at a point that execution will be achieved as close to the BS of the P-t-P transmission mode cell as possible (in order to reduce the downlink transmission power requirements for DCH) but not outside of the FACH supported area coverage limit (since outside of this area a QoS degradation is experienced).

Obviously, the "optimum" MBMS handover's execution point achieving the aforementioned is the FACH supported area coverage limit of the P-t-M transmission mode cell. Note that this is the point where the FACH capacity benefits are fully exploited. However, achieving execution of the MBMS handover (i.e. switch from FACH to DCH, or vice versa) exactly on the "FACH supported area" coverage limit, is not so straightforward and also risky, due to the challenges imposed by the varying motion of the user and the varying signal fluctuations occurring during its mobility (mostly due to the effect of fast fading). Thus, in order to handle this issue and avoid any possibility for an erroneous handover triggering to occur, we introduced the *Safety Margin (SM)* parameter in the

handover triggering decision, which dynamically regulates (only when necessary), the handover's execution point by shifting it from the "FACH supported area" coverage limit slightly inside the "FACH supported area" guaranteed coverage area.

More detailed description of the approach used to address the challenges imposed and achieve the performance goal is provided below.

### 3.6.1 Preliminaries

As indicated above, the aim of our proposed MBMS handover control approach is to execute the MBMS Handover (switch from FACH to DCH or vice versa) on the **FACH supported area coverage limit** of the P-t-M transmission mode cell (note that this is the "optimum" MBMS Handover's execution point). The FACH supported area coverage limit can be better described as the point where the FACH provides the required quality with the "minimum" required  $E_b/N_0$ , essential for correctly detecting the signal. The "minimum" required  $E_b/N_0$  for a service denotes the minimum value that the signal energy per bit ( $E_b$ ) divided by the interference and noise power density ( $N_0$ ) should have for achieving a certain BER (Bit Error Rate) so as to decode the signal correctly and thus satisfy the required QoS of the service.

With the current 3GPP handover control approach currently implemented on the UEs, the main input in making the handover triggering decision is the CPICH  $E_c/N_0$  signal quality received by the UE from the BSs within reach. Thus, with our MBMS handover control approach, we use the same measurable input for triggering the handover by equivalently expressing the "minimum FACH  $E_b/N_0$  required" to a "minimum CPICH  $E_c/N_0$  required" value. This equivalent expression is feasible, considering that the function of the CPICH in a cell, as defined by 3GPP, is to aid the channel quality estimation at the UE for the dedicated channel (i.e., the DCH) and to provide the channel quality estimation reference for the common channels (e.g., FACH). Furthermore, this equivalent expression is easy to make considering the following common characteristics of FACH and CPICH; fixed transmission

power and fixed spreading factor used during transmission, transmitted in the same propagation environment using the same multipath profile and BS antenna structure.

Thus, the aim of our MBMS handover control algorithm is to execute the “MBMS Handover” (i.e., switch from FACH to DCH, or vice versa) at the point where **the CPICH Ec/No signal quality measured from the P-t-M transmission mode cell**, becomes equal to the **minimum CPICH Ec/No required value** for indicating a reliable reception of the MBMS service using FACH.

In order to avoid any unnecessary or erroneous handovers, due to measurement errors it is important to **apply filtering on the CPICH Ec/No signal quality measurements to average out the effect of fast fading** (which causes fluctuations on the received signal quality). Appropriate filtering can increase the performance significantly. As long filtering periods can cause delays in the handovers, the length of the filtering period has to be chosen as a trade-off between the measurement accuracy and the handover delay. Also, the speed of the user matters. The slower the user is moving the harder it is to average out the effects of fast fading. Often a filtering period of 200 ms is chosen which we adopt for the studies of our research. Adaptive strategies can also be adopted, but this is left for further study. It is important to indicate here that the purpose of this filtering is to eliminate short-term variations in the signal while preserving the main trends. In practical terms, this type of filtering can prevent the UE from making unjustified handover decisions due to sudden changes occurring on the CPICH signal quality caused by fast fading.

The **minimum CPICH Ec/No required value**, indicating the FACH supported area coverage limit of the P-t-M transmission mode cell, will be pre-estimated by the Network Operator during the Radio Network Planning and be provided and stored locally in the User Equipment (UE) during the installation of the MBMS service. If for any reason the value of this parameter changes, it will be up to the application installed on the UE to perform an update procedure (after a notification from the network) and acquire any updates made.



### 3.6.2 Description of parameters and thresholds used

The aim of our proposed MBMS handover control approach is to facilitate an efficient handover triggering decision that will achieve execution on the FACH supported area coverage limit of the P-t-M transmission mode cell. As indicated above, this is the point where the **CPICH signal quality measured from the P-t-M transmission mode cell**, is equal to the **minimum CPICH Ec/No required** for indicating a reliable reception of the MBMS content using FACH.

However, achieving execution of the MBMS handover exactly on the “FACH supported area” coverage limit, is sometimes not so straightforward and also risky due to the challenges imposed by the varying motion of the user and the varying radio channel quality fluctuations occurring during its mobility (mostly due to the effect of fast fading). For example, the more inconsistent the mobility of the user or the radio channel quality received, the higher is the possibility for an erroneous handover triggering to occur which can result in QoS degradation (if the execution of the handover occurs outside of the “FACH’s supported area” guaranteed coverage). Thus, in order to lessen any possibility for QoS degradation to occur, we further introduce the **Safety Margin (SM)** parameter in the handover triggering decision. The aim of this parameter is to dynamically regulate (only if necessary) the handover’s execution point and shift it from the “FACH supported area” coverage limit slightly inside the “FACH supported area” guaranteed coverage area. We will refer to this point as the **“Practical Handover Execution Point (PHEP)”**. So the value of the SM will define the PHEP ( $\text{PHEP} = \text{minimum CPICH Ec/No required} + \text{SM}$ ). It is worth mentioning here that in cases where the consideration of the SM parameter is not essential (i.e.,  $\text{SM} = 0$ ), the “Practical Handover Execution Point (PHEP)” will be the same as the FACH supported area coverage limit. How the SM parameter is estimated is described in section 3.6.2.2.

Moreover, considering that some delay is caused from the time the handover is triggered until the UE switches channels (handover delay time), triggering the handover on the **“Practical Handover Execution Point (PHEP)”**, will result in the actual switching of

channels at some distance (referred as “Handover Delay Distance”) away from it. Thus, in order to accommodate this delay, we introduce the “**Pre-Trigger Predictor (PP)**” parameter. The aim of this parameter is to trigger the MBMS handover at a point (before the “Practical Handover Execution Point (PHEP)” is reached) that will result in its execution (i.e., switch from FACH to DCH, or vice versa) on the “*Practical Handover Execution Point (PHEP)*”. How the *Pre-Trigger Predictor (PP)* parameter is estimated is described in section 3.6.2.1.

The value of the *SM*, the *PP* and the *minimum CPICH Ec/No required* value indicating the “FACH supported area” coverage limit will be considered for the estimation of the “**Handover Trigger Threshold (HTT)**”. Note that, based on the inter-cell handover type that is likely to be executed, the *HTT* is estimated differently (see Figure 19):

- If the MBMS user is likely going to handover from a P-t-M transmission mode cell to a P-t-P transmission mode cell, then:

$$\mathbf{HTT = (Minimum CPICH Ec/No Required + SM) + PP} \quad (1)$$

- If the MBMS user is likely going to handover from a P-t-P transmission mode cell to a P-t-M transmission mode cell, then:

$$\mathbf{HTT = (Minimum CPICH Ec/No Required + SM) - PP} \quad (2)$$

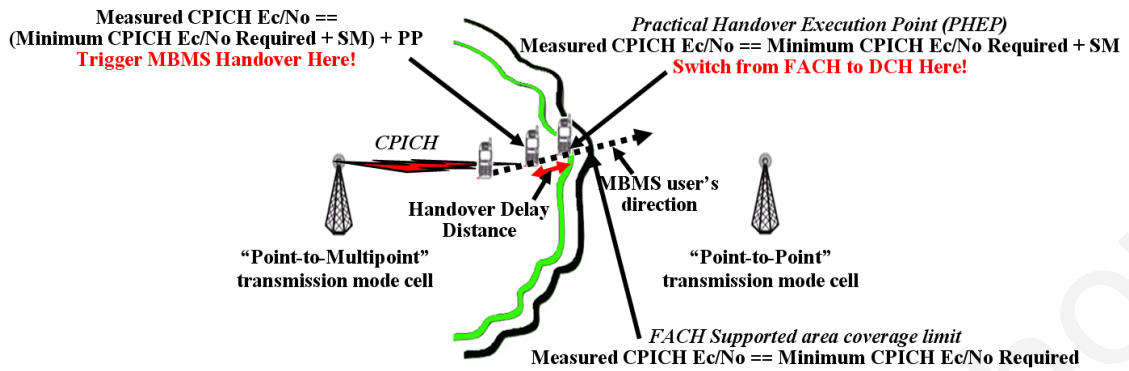

(a) The UE is moving from a Point-to-Multipoint towards a Point-to-Point transmission mode cell

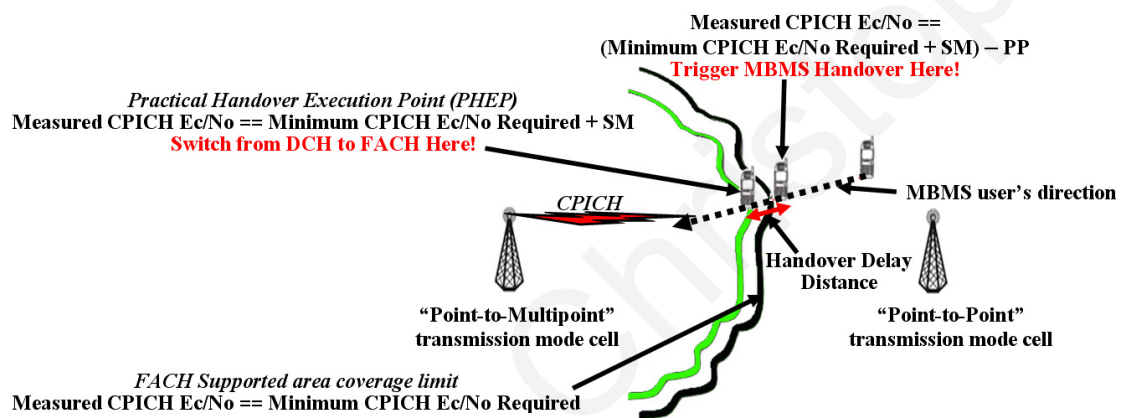

(b) The UE is moving from a Point-to-Point towards a Point to Multipoint transmission mode cell

Figure 19 Estimation of Handover Trigger Threshold (HTT)

Note that the UE is likely going to handover from a P-t-M to a P-t-P transmission mode cell only if:

- The serving cell is P-t-M transmission mode cell (i.e., the UE receives the MBMS service using FACH),
- The best neighbouring cell is a P-t-P transmission mode cell,
- The CPICH Ec/No alteration rate experienced from the serving cell is decreasing (i.e., the UE is moving away from the serving cell),

The UE is likely going to handover from a P-t-P to a P-t-M transmission mode cell only if:

- The serving cell is P-t-P transmission mode cell (i.e., the UE receives the MBMS service using DCH),
- The best neighbouring cell is a P-t-M transmission mode cell,
- The CPICH Ec/No alteration rate experienced from the serving cell is decreasing (i.e., the UE is moving away from the serving cell), and
- The CPICH Ec/No alteration rate experienced from the best neighbouring cell is increasing (i.e., the UE is moving towards the best neighbouring cell).

The role of the *HTT* is to indicate to the UE the exact point of triggering the handover so that it can be efficiently executed on the “*Practical Handover Execution Point (PHEP)*”. That is, the UE during its mobility will monitor the CPICH Ec/No signal quality of the P-t-M transmission mode cell and when equal to the *HTT* the handover will be triggered. It is worth mentioning that the value of the *HTT* can change through time, since it is highly affected by the varying motion of the UE. Thus, the value of the *HTT* must be continually and frequently estimated by the algorithm, during the UE’s mobility, in order to accommodate any changes on the user’s movement and achieve an accurate estimation of the *HTT* and thus an efficient MBMS handover execution.

Moreover, in order to prevent the UE from any unnecessary processing (and thus save also some battery), we introduce the idea of the “**Handover Activation Area (HAA)**”, inside which the handover is most likely to occur; i.e., the estimation of the *HTT* will occur only when the UE lies within this area. The size of this area is determined by the value set for the “**Activation Hysteresis (AH)**” parameter. The value of this parameter should be given a value which will provide to the UE enough time to ensure the accurate estimation of the *HTT* but not too much so as to introduce unnecessary processing by the UE. How this parameter is estimated, is described in section 3.6.2.3.

In order to assist the UE to indicate when the *Handover Activation Area (HAA)* is reached, we define the “**Handover Activation Threshold (HAT)**”. Thus, the role of this threshold is to indicate to the UE when to start or stop the processing required for the estimation of *HTT*.

Based on the inter-cell handover type that is likely to be executed, the *HAT* is estimated differently:

- If the UE is likely going to handover from a P-t-M to a P-t-P transmission mode cell, then:

$$\mathbf{HAT = Minimum CPICH Ec/No Required + AH} \quad \mathbf{(3)}$$

- If the UE is likely going to handover from a P-t-P to a P-t-M transmission mode cell, then:

$$\mathbf{HAT = Minimum CPICH Ec/No Required - AH} \quad \mathbf{(4)}$$

Once the *HAT* is estimated, the *Handover Activation Area (HAA)* will be defined as the area (see Figure 20) between the *FACH supported area coverage limit* and the point where the measured CPICH Ec/No signal quality (received from the P-t-M transmission mode cell) equals to the *HAT*. It is worth mentioning that the *HAT* can be adjusted through time based on the varying motion of the UE, in order to accommodate any changes on the UE’s movement and efficiently define the *Handover Activation Area (HAA)* that will facilitate an accurate estimation of the *HTT*.

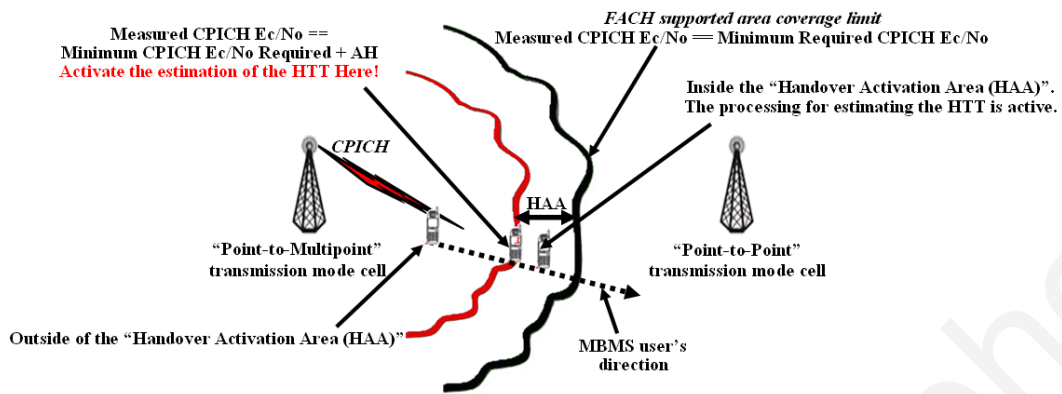

(a) The UE is moving from a Point-to-Multipoint towards a Point-to-Point transmission mode cell

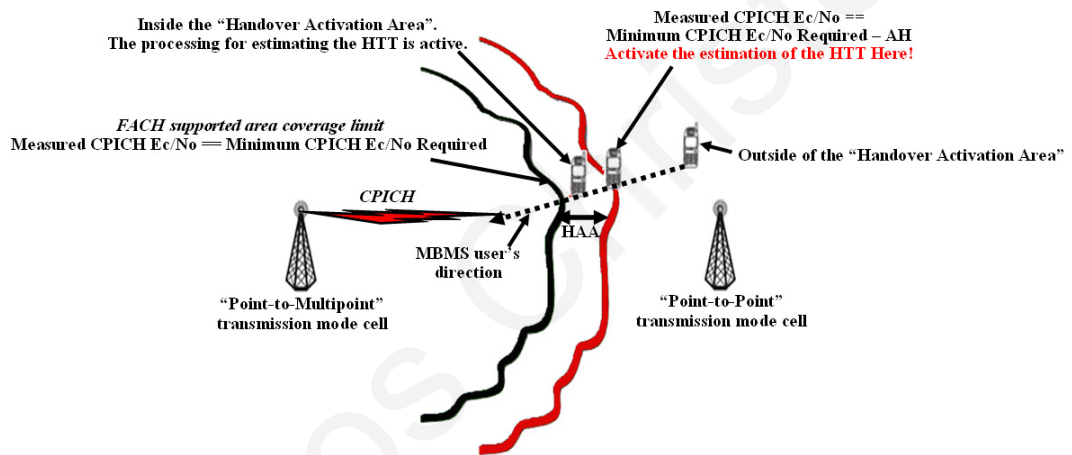

(b) The UE is moving from a Point-to-Point towards a Point to Multipoint transmission mode cell

Figure 20 Estimation of Handover Activation Threshold (HAT)

The aforesaid outlines the main concept of our proposed MBMS handover algorithm and also the parameters and thresholds vital for the efficient handover execution are discussed. Next we present the details of our algorithm. It is worth mentioning again that the MBMS handover algorithm we propose is applicable only when the UE is likely to perform a handover from a “Point-to-Point” to a “Point-to-Multipoint” transmission mode cell, or vice versa.

### 3.6.2.1 Pre-Trigger Predictor (PP) parameter

As indicated above, the role of the *Pre-Trigger Predictor (PP)* is to accommodate the handover delay caused from the time the handover is triggered until the UE switches channels. Thus, its aim is to adjust the value of the *HTT* in such a way that the handover to be triggered at a point (before the “Practical Handover Execution Point” is reached) that will result in its execution (i.e., switch from FACH to DCH, or vice versa) on the “*Practical Handover Execution Point (PHEP)*”. The value of the *PP* parameter (see equation (5)) is estimated by considering two parameters:

- **Handover delay time ( $\Delta t$ ):** This value will be estimated by the RNC (by considering the current handover delay times experienced by other UEs in the cell) and broadcast to the UEs through the *MBMS Point-to-Multipoint Control Channel (MCCH)* [2][9]. The MCCH is an MBMS specific control channel transmitted within all the cells supporting an MBMS service and used for providing MBMS control information to all UEs supporting MBMS services, irrespective of their state (idle, URA\_PCH, CELL\_PCH, CELL\_FACH and CELL\_DCH). The information on MCCH is transmitted using a fixed schedule, which is common for all services.
- **CPICH Ec/No Alteration Rate (CPICH Ec/No AR) experienced** from the Point-to-Multipoint transmission mode cell: The value of this parameter, will be estimated dynamically by the UE itself, by utilizing the previous and current measurements performed on the CPICH received only from the Point-to-Multipoint transmission mode cell. The idea behind this is fairly simple; the UE during its mobility will continually measure the CPICH Ec/No signal quality received from the Point-to-Multipoint transmission mode cell and store the values of the previous and instantaneous received signal quality received. The previous and the instantaneous CPICH Ec/No signal qualities will then be compared in order for the UE to indicate how rapidly the signal quality, received from the Point-to-Multipoint transmission mode cell, improves (in this case the CPICH Ec/No alteration rate will be positive) or

degrades (in this case the CPICH Ec/No alteration rate will be negative) during its mobility.

$$PP = |CPICH\ Ec/No\ AR \times \Delta t| \quad (5)$$

As indicated in section 3.6.1, in order to avoid any unnecessary or erroneous handovers, due to measurement errors, filtering (with filtering period 200ms) is applied on the CPICH Ec/No signal quality measurements to average out the effect of fast fading (which causes sudden fluctuations on the received signal quality). Thus, by using this 200 ms filtering period, the CPICH Ec/No alteration rate can be estimated by the UE every 200 ms.

It is worth mentioning that the value of the  $PP$  can change through time, since it is highly affected by the  $CPICH\ Ec/No\ Alteration\ Rate$  experienced by the UE and the  $handover\ delay\ time\ (\Delta t)$  that can be caused. The CPICH Ec/No Alteration Rate may vary through time due to alterations occurring on the UE's movement and also the handover delay time, can vary through time (however not so frequently) due to variation on the overall system load. Thus, the  $PP$  is a parameter that must be continually and frequently estimated by the algorithm during the UE's mobility, in order to accommodate any changes that occur and adjust the  $HTT$  value accordingly.

### 3.6.2.2 Safety Margin (SM) parameter

The role of the  $SM$  parameter in the  $HTT$  estimation, is to eliminate any possibility for QoS degradation to occur, by regulating the MBMS handover's execution point and shifting it (if necessary) from the "FACH supported area" coverage limit slightly inside the "FACH supported area" guaranteed coverage area. As shown in equation (6), the value of the  $SM$  is based on three parameters; the  $CPICH\ Ec/No\ Alteration\ Rate$  (CPICH Ec/No AR) experienced by the UE from the P-t-M transmission mode cell, a fixed amount of time  $St$  (we



will refer to this amount of time as the “*Safety time (St)*”) and the possibility  $p$  of an erroneous handover triggering to occur.

$$SM = |CPICH Ec/No AR x St x p| \quad (6)$$

The value of the  $St$  should be selected by the Network Operator (during Radio Network Planning) as a tradeoff between the QoS desired to be supported and the capacity gains desired to be achieved. Note that the smaller the value of the  $St$  (and thus the smaller the value of the  $SM$ ), the higher the capacity gains that can be achieved (since the MBMS handover will be executed closer to the “FACH’s supported area” coverage limit and thus closer to the Base Station of the P-t-P transmission mode cell) but the higher the possibility for QoS degradation and frequent inter-cell handovers (i.e., the ping pong effect) to occur. It is worth mentioning here that in order to limit the ping pong effect, a “**waiting period**” time between subsequent handovers triggering is set (which is also considered and included in the value of  $St$ ). More specifically, the  $St$  includes this “waiting period” plus an amount of time considered essential, by the Network Operator, for eliminating any possibility for QoS degradation. The value of the  $St$  will be provided and stored locally in the UE during the installation of the MBMS service application on the Mobile Device (MD). If, for some reason, the value of this parameter changes, it will be up to the application installed on the UE to perform an update procedure (after a notification from the network) and acquire, using RRC signalling, any updates made. For example, if the cell becomes low loaded and capacity is not an issue, the RNC can dynamically increase the value of the  $St$  and sacrifice some capacity for improved QoS. On the other hand, if capacity is getting limited, the RNC can dynamically decrease the value of the  $St$  and sacrifice QoS for improved capacity.

Furthermore, the value of the  $SM$  parameter will be dynamically adjusted by the algorithm running in the UE based on the possibility  $p$  of an erroneous handover triggering to occur. The

value of the parameter  $p$  is estimated by the algorithm by considering the different fluctuations occurring on the subsequent CPICH  $E_c/N_0$  measurements during the UE's mobility. For the estimation of this parameter  $p$ , the algorithm during the UE's mobility, stores the subsequent values of the CPICH  $E_c/N_0$  signal quality measured from the P-t-M transmission mode cell of the last 10 seconds of its movement. These values are then considered by the algorithm in order to assist it to estimate how inconsistent the radio channel quality is and predict the possibility  $p$  ( $0 \leq p \leq 1$ ) of an erroneous handover execution (or the ping pong effect) to occur. Then, the value of the  $SM$  is regulated according to the parameter  $p$ . The more inconsistent the quality of the radio channel (i.e., the more frequent the fluctuations between subsequent CPICH  $E_c/N_0$  signal quality measurements), the higher the possibility  $p$  of an inefficiency to occur and thus the higher the value of the  $SM$  parameter. If on the other hand, the radio channel quality is consistent, the possibility  $p$  of an inefficiency to occur will be zero and thus the value of the  $SM$  will be zero. Moreover, the direction of the UE with reference to the P-t-M transmission mode cell can also be considered for the estimation of the parameter  $p$ . For the estimation of the UE's direction various methods can be used [69] [70]. The Observed Time Difference of Arrival (OTDOA) and the Assisted GPS positioning approaches were selected for UMTS networks by the 3GPP [25].

The consideration of the parameter  $p$  in the estimation of the  $SM$  improves the performance considerably since in cases where the use of the  $SM$  is not crucial (i.e., in cases where there is not any possibility for an erroneous handover triggering to occur), it will not be considered and thus maximum capacity gains will be achieved. However, for this issue some intelligence is required in the UE in order to estimate this possibility  $p$ . Due to its complexity (i.e., the unpredictable behaviour of users' mobility) and importance for our algorithm we will study it further in future work. It is worth mentioning that the value of the possibility  $p$  is estimated only once and that is when the *Handover Activation Area (HAA)* is reached.

As illustrated in equation (6), the value of the  $SM$  is affected by the *CPICH  $E_c/N_0$  Alteration Rate* experienced by the UE, which can vary through time. Thus, the  $SM$  is a

parameter that must be continually estimated by the algorithm during the UE's mobility, in order to accommodate any changes occurred and adjusts the “*Practical Handover Execution Point (PHEP)*” (and thus the value of the *HTT*) accordingly.

### 3.6.2.3 Activation Hysteresis (AH) parameter

As indicated above, the *Activation Hysteresis (AH)* parameter is used in order to define the size of the “**Handover Activation Area (HAA)**” inside which the MBMS handover is most likely to occur and prevent the UE from any unnecessary processing; i.e., the estimation of the *HTT* will occur only when the user lies within this area. The value of this *AH* parameter should be given a value which will provide to the UE enough time to ensure the accurate estimation of the *HTT* but not high enough so as to introduce unnecessary processing by the UE (i.e., avoid having the UE estimating the *HTT* in an area where the MBMS handover is impossible to occur and thus reduce processing power and also battery consumption). The value of this parameter is highly affected by the motion of the UE (i.e., the *CPICH Ec/No Alteration Rate* experienced by the UE from the P-t-M transmission mode cell) and the **Activation time (At)** parameter. The value of the *At* parameter will be fixed and selected by the Network Operator during the Radio Network Planning. Thus, the value that the *AH* will take will be equal to:

$$AH = |CPICH Ec/No AR \times At| \quad (7)$$

Note that the value of the *At* will be provided and stored locally in the UE during the installation of the MBMS service application on the Mobile Device (MD). If, for some reason, the value of this parameter changes, it will be up to the application installed on the UE to perform an update procedure (after a notification from the network) and acquire, using RRC signalling, any updates made.

As illustrated in equation (7), the value of the  $AH$  is affected by the  $CPICH$   $Ec/No$  Alteration Rate experienced by the UE, which can vary through time. Thus, the  $AH$  is a parameter that must be continually estimated by the algorithm during the UE's mobility, in order to accommodate any changes and adjusts the  $HAT$  (and thus the size of the  $HAA$ ) accordingly.

However, it is worth mentioning that in order to further eliminate the need by the algorithm to dynamically estimate the value of the  $AH$  when it is not necessary, an initial value for the Activation Hysteresis (**initial AH**) will be estimated by the Network Operator (based on the worst case scenario) and provided to the UE during the installation of the MBMS application on the Mobile Device (MD). This *initial AH* value will be fixed and used in order to estimate an **initial HAT** that will be considered by the algorithm before the dynamic estimation and adaptation of the  $HAT$  takes place.

Thus, the dynamic estimation of the  $AH$  value (and thus the  $HAT$  value), will be triggered by considering the *initial HAT* value. For example, assuming a UE moving from a P-t-P to a P-t-M transmission mode cell, the dynamic estimation of the  $AH$  (and thus the dynamic estimation of the  $HAT$ ) will be performed only when the measured  $CPICH$   $Ec/No$  signal quality measured from the P-t-M transmission mode cell is equal to or stronger than the *initial HAT* value.

### 3.6.3 Description of proposed MBMS Handover control approach

In this section we present in more detail our proposed MBMS handover control approach. It is worth pointing out that in order to minimise execution time overhead, the main algorithm is activated only when the MBMS user is in the "*Handover Activation Area (HAA)*". Therefore, our proposed MBMS handover algorithm is divided into two phases (see Figure 21):

- **Phase 1:** Outside of the Handover Activation Area (HAA)
- **Phase 2:** Inside the Handover Activation Area (HAA)

Phase 2 is further divided into two more steps that are initiated based on two thresholds:

- **Activation Step:** Initiated by the Handover Activation Threshold (HAT)
- **Trigger Step:** Initiated by the Handover Trigger Threshold (HTT)

In order to ease the comprehension of the proposed MBMS handover approach description, we consider the case where an MBMS user is receiving the MBMS service in the serving cell using DCH (i.e., the MBMS user is located in a Point-to-Point transmission mode cell) and moving towards a Point-to-Multipoint transmission mode cell (see Figure 21). It should be mentioned that the same logic can be applied for the reverse case as well (i.e., from P-t-P to P-t-M transmission mode cell).

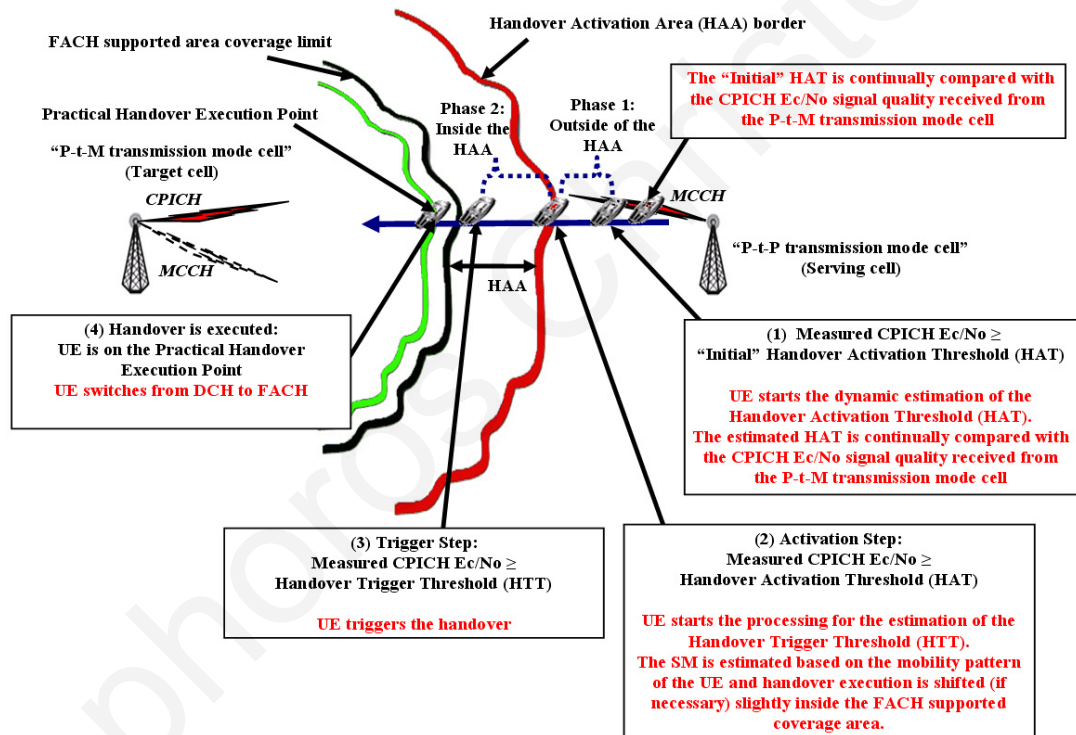

Figure 21 Proposed MBMS handover approach description

### Phase 1: Outside the Handover Activation Area (HAA):

The UE is located in a Point-to-Point transmission mode cell and receives the MBMS service using DCH. During its mobility it continually measures the CPICH Ec/No signal quality transmitted from the serving and neighbouring BSs, ranks the neighbouring BSs according to their CPICH Ec/No signal quality received, and identifies the best neighbouring

cell (i.e., the target cell). The UE reads the information included in the MCCH (broadcast within its serving cell) concerning how the MBMS service is provided within the target cell and indicates that the MBMS service is provided using P-t-M transmission mode.

Upon indicating that, the UE acquires from its memory the value designating the FACH's supported area coverage of the target P-t-M transmission mode cell (i.e., the *minimum CPICH Ec/No required* to be received by the UE from the P-t-M transmission mode cell for indicating a reliable reception of the MBMS service using FACH) and the *initial Activation Hysteresis (initial AH)* value set by the Network Operator, and estimates the *initial Handover Activation Threshold (initial HAT)*. Note that the *initial HAT* is estimated only once. Once estimated, and assuming that the same status remains (i.e., the target cell is not changed and the transmission mode used in both the serving and target cells remains the same), the *initial HAT* is continually compared with instantaneous CPICH Ec/No signal quality measured from the P-t-M transmission mode cell.

When the instantaneous CPICH Ec/No signal quality measured from the P-t-M transmission mode cell becomes equal to or stronger than the *initial HAT*, the algorithm will start dynamically regulating the *Activation Hysteresis* and the *Handover Activation Threshold*, by considering the mobility of the MBMS user (i.e., the instantaneous CPICH Ec/No alteration rate experienced by the UE) and the "*Activation time (At)*" set by the Network Operator, which is stored locally in its memory.

Thus, once the *initial HAT* is reached, and while the instantaneous CPICH Ec/No signal quality measured from the P-t-M transmission mode cell is stronger than the *initial HAT*, the algorithm, dynamically regulates the *AH* value based on the motion of the user and the *At* time and adjusts the size of the *Handover Activation Area (HAA)* accordingly. Every time the *AH* value is regulated a *new HAT* value will be estimated.

The *new HAT* value is then compared with the instantaneous CPICH Ec/No signal quality received by the UE from the P-t-M transmission mode cell. When the CPICH Ec/No signal

quality received becomes *equal to* or *stronger than* ( $\geq$ ) the *new HAT*, the algorithm transits to Phase 2, otherwise it remains in Phase 1.

Note that once transiting to Phase 2, the dynamic regulation of the *AH* value and thus the dynamic estimation of the *HAT* value will stop. The *Handover Activation Area border* will then be defined based on the **latest HAT** value estimate.

**Notes:** In order to further reduce the processing effort required by the UE for the dynamic estimation of the HAT, this threshold will be estimated only when:

- A change occurs on the CPICH Ec/No alteration rate experienced by the UE. Otherwise there is not need to re-estimate it since the new value will be equal to the one previously estimated.
- The CPICH Ec/No alteration rate experienced by the UE from the “Point-to-Multipoint” transmission mode cell is increasing (i.e., the UE is moving towards the P-t-M transmission mode cell). Otherwise, there is no need to be estimated since the UE is either stable or moving away from the P-t-M transmission mode cell, and thus an MBMS handover is not likely to occur.

Similar logic is applied with the vice versa case of inter-cell handover (i.e., from P-t-M to P-t-P transmission mode cell).

### **Phase 2: Inside the Handover Activation Area (HAA)**

**Activation Step:** This step is initiated upon transition to Phase 2 and indicates to the UE that it has entered the “*Handover Activation Area (HAA)*”. The UE upon entering in this area starts the estimation of the *Handover Trigger Threshold (HTT)*. Note that the *HTT* depends on three parameters; the *minimum CPICH Ec/No required* to be received (from the P-t-M transmission mode cell) for indicating a reliable reception of FACH, the *Safety Margin (SM)* and the *Pre-Trigger Predictor (PP)*.

The *minimum CPICH Ec/No required* value is already known to the UE from Phase 1. The *Safety Margin (SM)* and the *Pre-trigger Predictor (PP)* parameters, on the other hand, will be estimated by the algorithm once the Activation step is reached and adjusted (when necessary) accordingly, until the handover is triggered.

The *Safety Margin (SM)* depends on three parameters; the *CPICH Ec/No alteration rate experienced* by the UE, the *Safety time (St)* and the possibility  $p$  of an erroneous handover triggering to occur. The  $St$  has a fixed value (set by the Network Operator) and is stored locally in the UE's memory. The possibility  $p$  of an erroneous handover triggering will be estimated once the Activation step is initiated. The *CPICH Ec/No alteration rate*, on the other hand, is a parameter that can change through time due to the varying motion of the MBMS user. Thus, this makes the *Safety Margin (SM)* to also vary and thus should be periodically estimated while the UE is within the *Handover Activation Area (HAA)*.

The initial value of the SM will be estimated by the algorithm once the Activation step is reached. Then, assuming that the UE is still within the Handover Activation Area, the value of the SM will be dynamically regulated based on the instantaneous CPICH Ec/No alteration rate experienced by the UE. Note that once the SM is estimated, the Practical Handover Execution Point (PHEP) will be also defined ( $\text{PHEP} = \text{minimum CPICH Ec/No required} + \text{SM}$ ).

The *Pre-Trigger Predictor (PP)* depends on the *CPICH Ec/No alteration rate* experienced by the UE and the *handover delay time ( $\Delta t$ )* that can be caused based on the current system load. The CPICH Ec/No alteration rate is a parameter that may vary rapidly through time (due to variations on MBMS user's movement) and must be continuously estimated by the UE during its mobility. Moreover, the  $\Delta t$  is also a parameter that can vary through time due to variations on the overall system load and must be continually monitored (note that this value is broadcast through the MCCH). Thus, the value of the *PP* will be continually estimated in order to achieve an efficient handover triggering.

Therefore, the UE during its mobility within the *Handover Activation Area (HAA)* will continually estimate the HTT (i.e., based on the latest *SM* and *PP* values) and compare it with



the measured CPICH Ec/No signal quality received from the P-t-M transmission mode cell. When the measured CPICH Ec/No signal quality becomes *equal to* or *stronger than* ( $\geq$ ) than the *HTT* it will transit to the Trigger Step in which the MBMS handover is triggered.

Note that from within the Activation Step, if the CPICH Ec/No signal quality measured by the UE from the P-t-M transmission mode cell becomes weaker than ( $<$ ) the *latest HAT* estimated value (meaning that the UE has left the *Handover Activation Area (HAA)*) then the algorithm goes back to Phase 1.

**Notes:** In order to further reduce the processing effort required by the UE, the *Handover Trigger Threshold (HTT)* will be estimated only when:

- A change occurs either on the CPICH Ec/No alteration rate experienced by the UE, or on the  $\Delta t$  that can be caused. Otherwise there is no need to re-estimate it since the new value will be equal to the one previously estimated.
- The CPICH Ec/No alteration rate experienced by the UE from the P-t-M transmission mode cell is increasing (i.e., the UE is moving towards the P-t-M transmission mode cell). Otherwise, there is no need to be estimated since the UE is either stable or moving away from the P-t-M transmission mode cell and thus an MBMS handover is not likely to occur.

**Trigger Step:** The UE prepares the handover request and triggers the handover by sending the handover request to the RNC. The RNC processes the request and executes the handover.

For easy reference, the MBMS handover algorithm described above is also summarized using the flowcharts illustrated in Figure 22. The steps and activities that will be performed in case the UE is likely to handover from a P-t-P to a P-t-M transmission mode cell are described in Figure 22.a. On the other hand, Figure 22.b describes the steps and activities that will be

performed in case the MBMS user is likely to handover from a P-t-M to a P-t-P transmission mode cell.



(a) From P-t-P towards a P-t-M transmission mode cell (b) From P-t-M towards a P-t-P transmission mode cell

Figure 22 Flowcharts of Proposed MBMS Inter-cell Handover algorithm

### 3.6.3.1 Importance of Pre-Trigger Predictor (PP) Parameter

The aim of the PP parameter is to accommodate the handover delay time ( $\Delta t$ ) caused and avoid any capacity inefficiency or QoS degradation during an MBMS handover. In order to

investigate the amount of handover delay time ( $\Delta t$ ) that is tolerated when an MBMS handover is performing, a series of scenarios have been simulated observing a  $\Delta t$  of about 1 second.

Taking into consideration the  $\Delta t$  value indicated above, we demonstrate the importance of the  $PP$  parameter in the handover triggering and also the QoS and capacity efficiencies achieved by our algorithm during an inter-cell handover. For the demonstrated scenarios used, the UE is expected to receive an MBMS streaming video of 64 Kbits/sec (64000 bits/sec) while the radius of the cells taking part in the handover is configured to be 1000 meters.

First we demonstrate the impact of the  $PP$  parameter on the QoS experienced by the user during an MBMS handover from a Point-to-Multipoint to a Point-to-Point transmission mode cell. As indicated in section 3.6.1, in this case of handover (assuming that the  $SM$  value is set to zero), the handover will be triggered when the measured  $CPICH Ec/No$  equals to *minimum  $CPICH Ec/No$  required* minus (-)  $PP$ . If the  $PP$  is not considered (i.e.,  $PP = 0$ ) the handover will be triggered on the FACH supported area coverage limit, and the channel switching from FACH to DCH will occur  $\sim 1$  second after the “FACH supported area” is left (note that during this 1 sec the UE will continue receiving the service using FACH until the switching to DCH occurs). Since FACH guarantees the required QoS only up to the “FACH supported area” coverage limit, it is obvious that this will have some impact on the MBMS service’s QoS (traffic received). In order to illustrate this impact, six instances of the same scenario, each having the UE moving with a different speed, have been simulated.

As illustrated in Figure 23, the packet loss experienced when the  $PP$  is considered is up to a maximum of 0.96% when 120 Km/h speed is used. However, if  $PP$  is not considered, we have losses from 1.15% up to 6.32% for low speeds (5 and 15 Km/h) and from 18.2 % up to almost total collapse of the throughput for vehicular speeds (30, 60, 90 and 120 Km/h). For many streaming applications, an acceptable QoS can still be provided, if the packet losses in the received service from the UE do not exceed about 10%. This is met for all the cases when  $PP$  is considered.

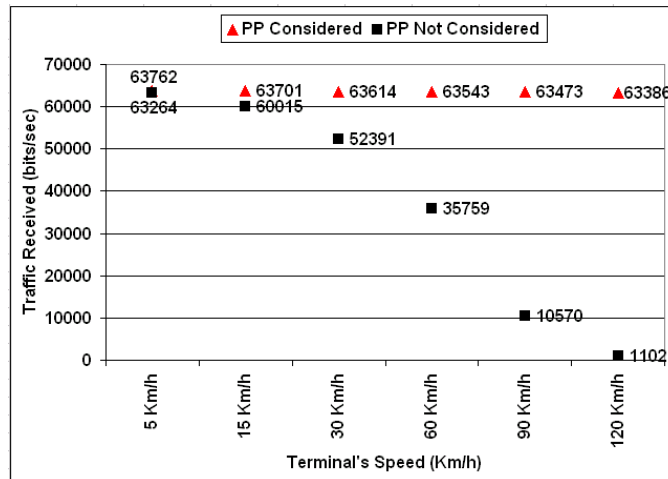

(a) Throughput received (bits/sec)

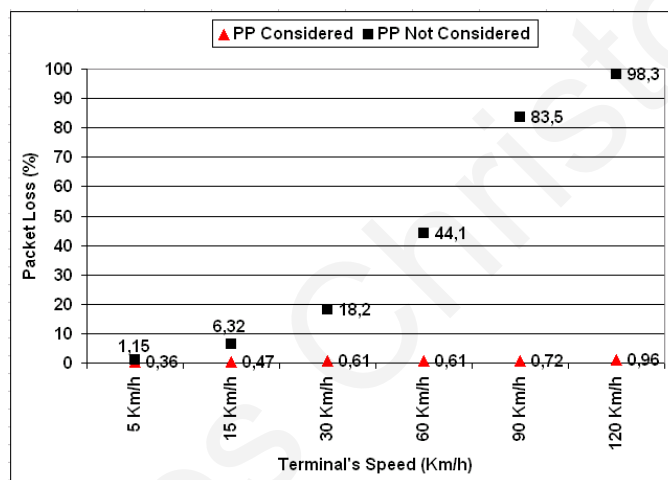

(a) QoS degradation – Packet loss (%)

Figure 23 Impact of the PP parameter on the QoS efficiency during an MBMS handover

Similarly, during an inter-cell handover from a Point-to-Point to a Point-to-Multipoint transmission mode cell, if the PP is not considered, the channel switching will be executed inside the “FACH supported area”, ~1 second after passing the “FACH supported area” coverage limit (note that during this ~1 second the UE will continue receiving the MBMS service using DCH until the switching to FACH occurs). However, the optimum case here would be to break the DCH connection and switch to FACH exactly on the “FACH supported area” coverage limit (since up to this point the FACH is adequate to guarantee the required QoS) in order to release the radio resources allocated for the DCH earlier and avoid any redundant use of power. The impact of the PP parameter on the capacity efficiency during this

type of inter-cell handover is illustrated in Figure 24 and Table 2. Similarly as above, in order to illustrate this impact, six instances of the same scenario, each having the UE moving with a different speed, have been simulated.

As illustrated in Figure 24 and Table 2, when the PP is considered we can have from 0.17% up to 0.57% gain on the maximum downlink power used for the DCH link in the P-t-P transmission mode cell, before the handover is executed, for speeds from 5 up to 15 Km/h, and from 2.25% up to 14.75% gain for speeds greater than 30 Km/h. As observed, the impact of the PP parameters on the capacity efficiency in the cases where the speed of the UE is lower than 15 Km/h (i.e. pedestrian speeds), is trivial. However, when the speed of the UE exceeds 30 Km/hour, the capacity gain that we can have exceeds 2.25 % (reaching up to 14.75% for the presented examples), which can be considered substantial given the scarcity and limitation of wireless radio resources. Therefore, in these cases, the PP parameter cannot be ignored.

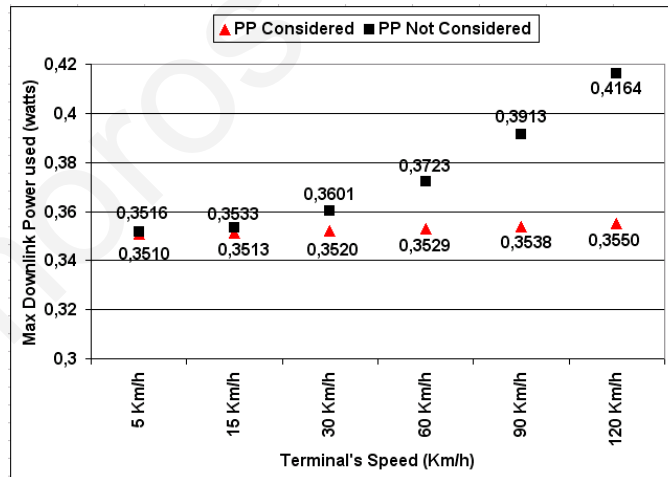

Figure 24 Impact of the PP parameter on the capacity efficiency during an MBMS handover

Table 2 Capacity gain achieved when the PP parameter is considered

Pre-Trigger Predictor Considered	Speed (Km/h)	5	15	30	60	90	120
	Max Power used (watts)	0,3510	0,3513	0,3520	0,3529	0,3538	0,3550
Pre-Trigger Predictor <u>NOT</u> considered	Speed (Km/h)	5	15	30	60	90	120
	Max Power used (watts)	0,3516	0,3533	0,3601	0,3723	0,3913	0,4164
Capacity Efficiency Gain when the Pre-Trigger Predictor is Considered (%)		0.17% gain	0.57% gain	2.25% gain	6.21% gain	9.58% gain	14.75% gain

We therefore conclude that in the cases where the speed of the UE is low (i.e., pedestrian), the PP parameter is not essential. In these cases the handover can be triggered on the FACH supported area coverage limit, thus the extra effort of dynamically estimating the PP will be eliminated. However, in the cases where the speed of the UE is higher than 15 Km/h, the PP is essential in order to avoid any QoS degradation and enhance the overall system capacity.

### 3.6.3.2 Considerations during an MBMS Handover

Due to fact that with the proposed MBMS handover approach execution of the MBMS handover (i.e., switching from DCH to FACH, or vice versa), is aimed to be achieved on the FACH supported area coverage limit of the Point-to-Multipoint transmission mode cell, we have to consider the cases where the UE, immediately after the MBMS handover's execution, decides to return back to the old cell. Note, that the considerations discussed below can be efficiently accommodated with the "*Safety Margin (SM)*" parameter considered during the estimation of the *HTT* threshold. However, in order to further improve performance and lessen the possibility of QoS or capacity inefficiencies to occur, the following two cases are also considered.

**Consideration 1:** The UE is moving from a Point-to-Multipoint (FACH) to a Point-to-Point (DCH) transmission mode cell and an MBMS Handover is executed. The UE upon leaving the FACH supported area coverage limit of the Point-to-Multipoint transmission mode cell (serving cell) will stop listening to the FACH and start listening to the new DCH established in the Point-to-Point transmission mode cell (target cell). But what if the UE

immediately, after the MBMS handover's execution, returns back to the Point-to-Multipoint transmission mode cell? If the DCH is not broken immediately, it would increase the power requirements (and thus interference) in the Point-to-Point transmission cell (see section 3.6.3.1; it is almost the same as when the Pre-Trigger Predictor is underestimated), additionally introducing unnecessary signalling load (for triggering the handover back to the P-t-M transmission mode cell), affecting the overall system performance.

**Solution 1:** In order to solve the aforementioned consideration we do the following. The UE upon starting to listen to the new DCH established in the Point-to-Point transmission mode cell, will stop listening to the FACH broadcast in the Point-to-Multipoint transmission mode cell, but it **will store the configuration of the FACH locally in its memory**. So in case the UE returns back to the Point-to-Multipoint transmission mode cell, it will send a message to the RNC to “**freeze**” the DCH established in the Point-to-Point transmission mode cell (for this see Consideration 2), and it will use the FACH configuration stored locally in its memory in order to be reconfigured and be able to listen to the FACH again. So the interference will not be increased in the Point-to-Point transmission mode cell since the time required for the DCH to be “frozen” and the UE to be reconfigured to listen to the FACH, is negligible. Moreover, no signalling overhead will be caused in this case because the reconfiguration will take place locally in the UE. Thus, with this solution the overall system capacity and performance, and the QoS level requested for the service will not be affected.

**Consideration 2:** The UE is moving from a Point-to-Point (DCH) to a Point-to-Multipoint (FACH) transmission mode cell and an MBMS handover is executed. The UE upon reaching the FACH supported area coverage limit of the Point-to-Multipoint transmission mode cell will stop listening to the DCH established in the Point-to-Point transmission mode cell and start listening to the FACH. Moreover, according to the 3GPP TR 25.922 specifying how the hard handover is performed, the UE upon start listening to the

FACH, the RNC will release the DCH established for this UE in the Point-to-Point transmission mode cell. But what if the UE immediately, after the MBMS handover execution, returns back to the Point-to-Point transmission mode cell? If the UE leaves the FACH supported area it would decrease the quality of the connection (see section 3.6.3.1; it is almost the same when the Pre-Trigger Predictor is underestimated), additionally introducing some signalling load for the request of a new DCH in the Point-to-Point transmission mode cell.

**Solution 2:** In order to solve the aforementioned consideration we do the following. Upon the UE's handover execution to the Point-to-Multipoint transmission mode cell, it will store the configuration of the DCH previously receiving the service, in the Point-to-Point transmission mode cell, locally in its memory. Moreover, the RNC instead of totally releasing the DCH established for this UE in the Point-to-Point transmission mode cell, it will just stop sending any data through this DCH (i.e., “freeze” the DCH), for a fixed amount of time (“Freeze time”), associating the IMSI of the UE with the Radio\_Bearer\_ID of “frozen” DCH. Thus, the DCH in the Point-to-Point transmission mode cell will not cause any interference since no power will be used to send any data through this channel. Thus, upon the MBMS user being handed over to the Point-to-Multipoint transmission mode cell, the RNC will “freeze” the DCH previously used by this user in Point-to-Point transmission mode cell, and a *Counter* will be initiated counting the time that this DCH remains “frozen”. The DCH in the Point-to-Point transmission mode cell will be released when  $Counter > Freeze\ Time$ . If the UE, immediately after the MBMS handover's execution (and before  $Counter > Freeze\ Time$ ), returns back to the Point-to-Point transmission mode cell, it will not have to trigger another MBMS handover again; it will just sent to the RNC a message requesting to activate again the DCH it was using previously in the Point-to-Point transmission mode cell. This message will include the Radio\_Bearer\_ID of the “frozen” DCH. When the RNC receives this message, it will respond to the UE indicating that the “frozen” DCH will be activated again and the RNC



will start sending the MBMS data through it. The UE upon receiving this response from the RNC it will be reconfigured using the DCH's configuration stored locally in its memory, and start listening again to the reactivated DCH. So the quality of the connection will not be decreased since the time needed for the UE to be reconfigured will be negligible. Moreover, the overhead caused here will be negligible without affecting the performance of the system (only two messages with negligible overhead are used; freeze and reactivate).

### 3.6.4 Processing - Memory requirements and Signalling Overhead

In this section we briefly analyze the processing complexity and memory requirements (both in UE and RNC) and the signalling overhead introduced with our proposed MBMS handover approach.

#### **Processing effort introduced in the UE:**

With the proposed approach the UE has to estimate the following thresholds:

- Handover Activation Threshold (HAT) using Eq. (3) or Eq. (4)
- Handover Trigger Threshold (HTT) using Eq. (1) or Eq. (2)

#### ***Processing effort required for the estimation of the HAT:***

The estimation of the “*Handover Activation Threshold (HAT)*” is performed only when the UE is *outside of the Handover Activation Area (HAA)* and its value is adapted according to the motion of the MBMS user. Its calculation involves the evaluation, of either **one addition** (Eq. 3) or **one subtraction** (Eq. 4) between two values of only one byte length each (the minimum CPICH Ec/No signal quality indicating the FACH supported area coverage limit of the P-t-M transmission mode cell and the Activation Hysteresis (AH)).

Furthermore, the estimation of the *Activation Hysteresis (AH)* value (Eq. 7) involves **one multiplication** between two values (the *CPICH Ec/No Alteration Rate* and the *Activation time (At)*) that are also one byte length. The CPICH Ec/No Alteration Rate is estimated by **subtracting** the instantaneous CPICH Ec/No signal quality (received from the P-t-M

transmission mode cell) from the one previous measured. The *Activation time (At)* is fixed and stored locally in the UE's memory

The estimation of the *HAT* will start after the CPICH Ec/No signal quality measured from the P-t-M transmission mode cell reaches a certain threshold (i.e., the *initial HAT*; which is estimated only once and its value is based on two fixed parameters of one byte length each) and re-estimated every time the CPICH Ec/No alteration rate experienced by the UE from the P-t-M transmission mode cell changes. Note that the CPICH Ec/No alteration rate experienced can be re-estimated every 200 ms (which is the filtering period used for CPICH Ec/No signal quality measurements). Thus assuming the worst case scenario where the CPICH Ec/No alteration rate experienced by the UE changes every 200 ms, the maximum number of instruction that will have to be performed every one second for the estimation of the HAT are:

- 5 subtractions for the estimation of the CPICH Ec/No alteration rate
- 5 multiplications for the estimation of the AH value using Eq. (7)
- 5 additions in case Eq. (3) is used or 5 subtractions in case Eq. (4) for the final estimation of the HAT

Based on a technical document of Intel [44] (and assuming that processors integrated in the Mobile Devices have similar characteristics), to perform an addition or a subtraction instruction between two floating numbers 3 clock cycles are required, and to perform a multiplication instruction between two floating numbers 5 clock cycles are required, the following processing effort will be required in the UE for the estimation of the HAT:

- Only **3 clock cycles** for the estimation of the **initial HAT**,
- Maximum of **55 clock cycles per second** for the estimation of the **new HAT**.

***Processing effort required for the estimation of the HTT:***

The estimation of the *Handover Trigger Threshold (HTT)* is performed only when the UE is *inside the Handover Activation Area (HAA)* (note that upon entering this area the estimation of the Handover Activation Threshold (HAT) stops). This is the area where most of the

processing occurs. Its calculation involves the evaluation, of either **two additions** (Eq. 1) or **one addition and one subtraction** (Eq. 2) between three values of only one byte length each (the *minimum CPICH Ec/No signal quality*, the *Pre-Trigger Predictor (PP)* and the *Safety Margin (SM)*).

The estimation of the *PP* parameter (Eq. 5), involves **one multiplication** between two values of one byte length each (the *CPICH Ec/No Alteration Rate* experience by the UE from the P-t-M transmission mode cell and the *handover delay time ( $\Delta t$ )* that can be caused).

The *CPICH Ec/No Alteration Rate* is estimated by **subtracting** the instantaneous CPICH Ec/No signal quality (received from the P-t-M transmission mode cell) from the one previous measured, while the  $\Delta t$  is acquired from the MCCH broadcast within the serving cell.

The estimation of the *SM* (Eq. 6), involves **two multiplications** between three values of one byte each (*CPICH Ec/No Alteration Rate* experienced by the UE from the P-t-M transmission mode cell, the *Safety time ( $S_t$ )* and the possibility  $p$  of an erroneous handover triggering to occur).

The  $S_t$  is fixed and stored locally in the UE's memory while the *CPICH Ec/No Alteration Rate* is already estimated when the *PP* was evaluated.

The possibility  $p$  of an erroneous handover triggering to occur will be estimated once the Activation Step is reached. This parameter  $p$  will be estimated by the algorithm by considering the subsequent CPICH Ec/No signal quality measurements performed (during the last 10 seconds of the UE's mobility; five samples per second  $\rightarrow$  50 samples in total) on the CPICH transmitted from the P-t-M transmission mode cell. These subsequent CPICH Ec/No measurements will be considered by the algorithm in order to depict the inconsistency of the radio channel's quality and estimate, based on this, the possibility  $p$  of an erroneous handover triggering to occur.

For example, the algorithm by considering the last 50 subsequent CPICH Ec/No signal quality measurements stored in its memory, checks the consistency between them (i.e., how they differ from each other). According to the frequency, the magnitude and number of

sudden fluctuations detected between the subsequent CPICH Ec/No signal quality measurements (these will define how consistent the radio channel quality is), the possibility  $p$  of an erroneous handover triggering is estimated.

Thus, assuming 50 subsequent estimations of the CPICH Ec/No signal quality, a total of **49 subtractions** between them will have to be performed in order to estimate the magnitude and the frequency of fluctuations, which the algorithm will consider for the estimation of the parameter  $p$ .

The estimation of the *HTT* will start once the Activation step is reached and has to be re-estimated every time a change occurs on the *PP* or the *SM* parameters. Since those parameters are highly affected by the CPICH Ec/No Alteration Rate, similarly to the *HAT*, assuming the worst case scenario where the CPICH Ec/No alteration rate experienced by the UE changes every 200 ms, the maximum amount of instructions that will have to be performed every one second for the estimation of the HTT are:

- 5 subtractions for the estimation of the CPICH Ec/No alteration rate
- 5 multiplications for the estimation of the PP value using Eq. (5)
- 10 multiplications for the estimation of the SM value using Eq. (6).
- 10 additions (in case Eq. 1 is used), or 5 additions and 5 subtractions (in case Eq. 2 is used), for the final estimation of the HTT.

Moreover, for the estimation of the possibility  $p$ , which will be estimated only once and this is when the Activation step is reached, requires (assuming that 50 subsequent CPICH Ec/No signal quality measurements are considered) a total of:

- 49 subtractions for the estimation of the magnitude and the frequency of radio channel quality fluctuations.

Considering, based on a technical document of Intel [44], that to perform an addition or a subtraction instruction between two floating numbers, 3 clock cycles are required, and to perform a multiplication instruction between two floating numbers, 5 clock cycles are

required, the following processing effort will be required in the UE for the estimation of the HTT:

- Only **147 clock cycles** for the estimation of the possibility  $p$  of an erroneous handover triggering to occur
- Maximum of **120 clock cycles per second** for the estimation of the **new HTT**.

Taking into account that the CPUs of newer mobile phones can run over 1 GHz (i.e. 1 billion clock cycles per second), the amount of processing required for the estimation of the aforementioned parameters and thresholds (not more than 150 clock cycles per second) can be considered trivial.

#### **Memory requirements in the UE**

The UE will have to store in its memory, for each cell and for each MBMS service that has joined, the following:

- **The CPICH Ec/No signal quality value indicating the FACH supported area coverage limit** (1 byte),
- **Initial Activation Hysteresis** (initial AH) value (1 byte) and
- **Safety time** ( $St$ ) value (1 byte)
- **Activation time** ( $At$ ) value (1 byte)

It is important to indicate here that the UE is not required to store the aforesaid values for all the cells that belong to the Network Operator but only those associated with the city that the MBMS user lives within. For example, assuming a Network Operator with let say 2000 cells covering a big city (i.e. London), 2000 distinct values will have to be stored in the UE's memory for each MBMS service that the MBMS user has joined. Thus **a total of 8 Kbytes** (i.e., 2000 cells x 4 bytes) are considered enough for storing the required values in the UE for each MBMS service.

Moreover, for the processing of the estimation of the HTT, HAT, PP, SM, AH,  $p$  parameters, the UE has to store in its memory the values related to the following parameters that will be utilized for the efficient MBMS Handover execution:

- Handover delay time (1 byte),
- CPICH Ec/No Alteration Rate (1 byte)
- Instantaneous CPICH Ec/No signal quality received (1 byte)
- 50 Previous CPICH Ec/No signal quality received (50 bytes)
- Pre-Trigger Predictor (1 byte)
- New Activation Hysteresis (1 byte)
- Safety Margin (1 byte)
- Possibility  $p$  of an erroneous handover triggering to occur (1 byte)
- Initial Handover Activation Threshold (1 byte)
- New Handover Activation Threshold (1 byte)
- Handover Trigger Threshold (1 byte)

Taking into account that the storage capacity of newer mobile phones can reach up to some Gbytes, the amount of memory required in the UE (only some Kilobytes) is trivial.

#### **Processing effort introduced in the RNC:**

With the proposed approach the RNC will have to estimate the handover delay time ( $\Delta t$ ) and broadcast it to the UEs through the MCCH. However, the estimation of the  $\Delta t$  requires marginal computational effort since the RNC in order to estimate this parameter will just consider the current  $\Delta t$  experienced by other UEs.

#### **Memory requirements in the RNC**

The RNC will have to store in its memory for each cell and for each MBMS service that it can be provided within the cell, the value indicating the FACH supported area coverage limit (1 byte), the initial Activation Hysteresis value (1 byte), the Safety time ( $S_t$ ) value (1 byte)

and the Activation time (At) value (1 byte). However, the RNC will have to store the values associated only for the cells that it controls. An RNC by definition needs to divide its limited processing resources among many Node-Bs. Typically, this means that a single RNC can only support a few hundred Node-Bs. Thus, assuming that an RNC can support 500 Node-Bs (i.e. cells), 500 distinct values will be required to be stored in the RNC for an MBMS service. Thus a total of **2 Kbytes** (500 x 4 bytes) are considered enough for storing the required values for a specific MBMS service in the RNC. Considering the amount of memory available in the RNC (up to some Terabytes), the amount of memory required, by our proposed approach, in the RNC is considered trivial.

#### **Signalling Overhead introduced:**

With the proposed approach the RNC has to continually broadcast the value of the handover delay time (through the MCCH) to the UEs receiving an MBMS service. Since this information can be transmitted using only **one byte**, the signalling overhead introduced in the downlink, by our approach, is considered trivial.

### **3.7 Performance Evaluation**

Our proposed MBMS handover control approach has been implemented (see Appendix C) and evaluated in the MBMS simulator [45]. This simulator was created during the B-BONE project using as a base the UMTS module provided by OPNET Modeller 11.0.A [46]. The scenarios used for the evaluation are described in section 3.7.1 while the results obtained are compared and analyzed in section 3.7.2.

#### **3.7.1 Scenarios Description**

The performance of our proposed MBMS handover control scheme was evaluated and compared against the 3GPP specified handover approach using the

- Total downlink power (capacity) required,
- Channel quality experienced and

- QoS level received (traffic received and packet loss).

In order to illustrate the performance, the feasibility and the usefulness of our proposed MBMS handover control approach a series of five scenarios have been simulated. The selection and use of these scenarios is justified in Table 3.

*Table 3 MBMS Handover Control – Scenarios selected*

<b>Scenario 1</b>	This is a simple two cell scenario and considers the case where some users are moving towards the cell where a stadium is located and a football match is ready to start shortly. Almost all the users have already reached the stadium while few others are still approaching. During this time, in order to entertain the crowd already in the stadium, but also those that are still approaching, a 64 Kbits/sec video clip is transmitted, showing the best scenes of past football matches between the two teams. In this scenario we assume that the major part of the crowd is already in the stadium and the cell that the stadium is located is transmitting the video clip using P-t-M transmission mode. The users that are still approaching the stadium are located in a P-t-P transmission mode cell. Thus, when entering the cell that the stadium is located they have to perform a handover from P-t-P to P-t-M transmission mode cell.
Scenario 2	Similarly to scenario 1, this scenario is a simple two cell scenario and considers the case where the football match is going to end shortly and some users, in order to avoid the traffic that will be caused after the football match is finished, they decided to leave the stadium some minutes earlier. During this time, in order to watch the end of the football match while they are moving away from the stadium they joined the MBMS service which provides the football match in a 64 Kbits/sec MBMS streaming video. In this scenario we assume that the MBMS service is provided in the cell where the stadium is located using P-t-M transmission mode and the users that left the stadium are moving towards a cell that the same MBMS service is provided using P-t-P transmission mode. Thus, when leaving the cell that the stadium is located they have to perform a handover from P-t-M to P-t-P transmission mode cell.
<b>Scenario 3</b>	Scenario 3, considers the case where a great amount of people are located in a shopping centre and moving randomly doing their shopping. Some people are either finished with their shopping and leaving the shopping centre, while some others are now approaching. During this time, in order to make the people aware of the different shops located in the shopping centre a 64 Kbits/sec MBMS video clip is transmitted, advertising the shops as well as the special offers that each shop provides. In this scenario we assume that the MBMS service is provided in the cell where the shopping centre is located using P-t-M transmission mode. The users that are leaving the shopping centre are moving towards a cell where the MBMS video clip is provided using P-t-P transmission mode (and thus performing a handover from P-t-M to P-t-P transmission mode cell), while the users that are approaching the shopping centre are located in a cell where the MBMS video clip is provided using P-t-P transmission mode (and thus performing a handover from P-t-P to P-t-M transmission mode cell).
<b>Scenario 4</b>	Scenario 4 is the same as scenario 1 but in this case we assume a more complex scenario, used for illustrating the feasibility and the performance of the proposed approach in a multi-cell environment (closer to real cellular environments) where the



	inter-cell interference is increased and also a mix of other unicast services (i.e., ftp, http, email, streaming video) are used. The aim of this scenario is to illustrate the link performance gains as well as the capacity benefits that can be achieved on the other unicast services in the central Point-to-Multipoint transmission mode cell where the stadium is located, when the proposed approach is applied.
<b>Scenario 5</b>	Scenario 5 is similar to scenario 1 and scenario 4 (multi-cell scenario), however this scenario considers the case where the stadium is still empty and groups of users are slowly approaching the stadium from surrounding cells. Here we assume that all the surrounding cells provide the MBMS video clip using P-t-M transmission mode. The central cell where the stadium is located provides the MBMS video clip using P-t-P transmission mode.

Scenarios 1 to 3 are used for illustrating the feasibility and the performance of the proposed approach in pedestrian and vehicular environments. On the other hand, scenario 4 and 5 are more complex scenarios, used for illustrating the feasibility, the performance, and the usefulness of the proposed approach in a multi-cell environment (closer to real cellular environments) where the inter-cell interference is increased. Scenarios 1 and 2 are further described in section 3.7.1.1, scenario 3 in section 3.7.1.2, scenario 4 in section 3.7.1.3 and scenario 5 in section 3.7.1.4.

*Table 4 MBMS Handover Control Scenarios - Simulation Parameters used*

<b>Simulation Parameter</b>	<b>Value</b>
MBMS service	Streaming video of 64 Kbits/sec
Cell radius	1000 meters
Node-B spacing	~1800 meters (~200 meters overlap)
Node-B Antenna type	Omnidirectional
Shadow fading	log-normal standard deviation of 10 dB
Transmission Time Interval (TTI)	20 ms ( <i>as suggested in [43]</i> )
Channel coding	Convolutional 1/3 coding rate
Downlink Other-cell Interference factor	1.78
Thermal Noise power spectral density	-174 dBm
Orthogonality factor	0.5
Safety time (St)	2 seconds
Activation time (At)	5 seconds
P-t-M cell's coverage limit (CPICH Ec/No)	- 5 dB

### 3.7.1.1 Scenario 1 and Scenario 2

Scenario 1 considers the case where a group of 10 UEs are receiving an MBMS service and moving from a P-t-P towards a P-t-M transmission mode cell, while scenario 2 considers the vice versa case (Figure 25). The simulation parameters used are provided in Table 4. Each scenario has been simulated using the current 3GPP specified and our proposed MBMS handover approach respectively. Two instances of each scenario have been simulated using a pedestrian outdoor (speeds of ~6Km/h) and a vehicular (speeds of ~60Km/h) environment. The results collected relate to the capacity (downlink transmission power) requirements of each algorithm, during the MBMS handover process. The results collected from these scenarios are presented, compared and analysed in section 3.7.2.1.

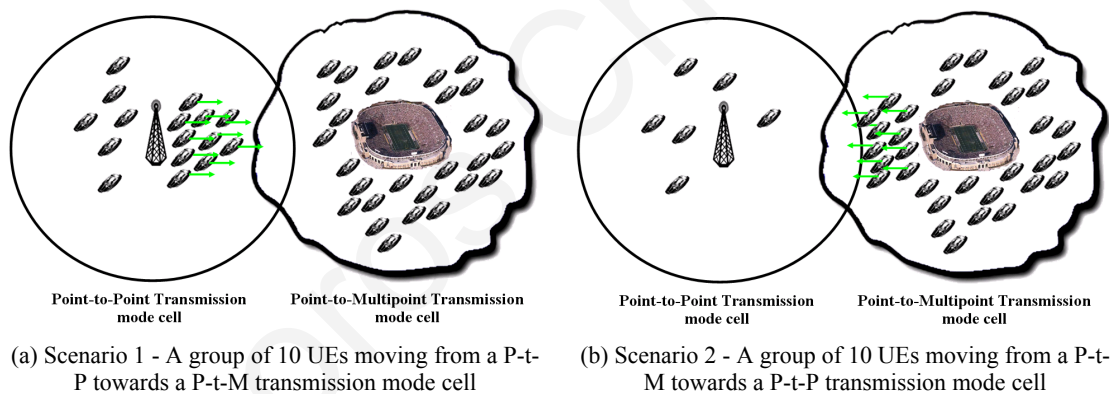

Figure 25 MBMS Handover Control - Scenario 1 and Scenario 2

### 3.7.1.2 Scenarios 3

In scenario 3 (see Figure 26), a total of 30 MBMS users, 15 in P-t-P transmission mode cell (UE 1 – UE 15) and 15 in P-t-M transmission mode cell (UE 16 – UE 30), are receiving an MBMS streaming video and are moving with a low vehicular speed (between 30 and 40 Km/h) following a trajectory towards the opposite cell. The MBMS session is set to start at the 110th second of the simulation. The simulation parameters used are provided in Table 4.

The minimum CPICH  $E_c/N_0$  signal quality required for guaranteeing a reliable reception of the MBMS streaming video using FACH is  $-5$  dB. The scenario has been simulated using the current 3GPP specified and our proposed MBMS handover algorithm respectively. Results related to the capacity (downlink transmission power) requirements and the QoS experienced by the users were collected and compared in section 3.7.2.2.

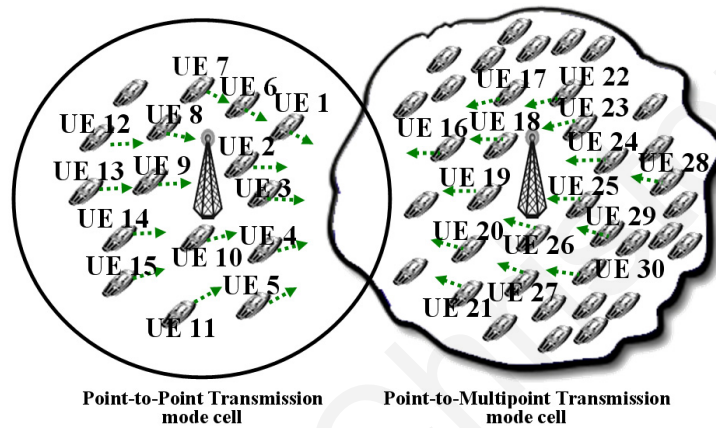

Figure 26 MBMS Handover control - Scenario 3

### 3.7.1.3 Scenario 4

Scenario 4 (see Figure 27), considers the case where groups of UEs are moving from surrounding P-t-P transmission mode cells towards a central P-t-M transmission mode cell. The UEs are moving with a speed of 6 Km/h, in a “Pedestrian Outdoor” environment and receiving an MBMS streaming video of 64Kbits/sec. In the central P-t-M transmission mode cell where the stadium is located, the users are either static or set to move with pedestrian speed receiving either the same MBMS streaming video, or other unicast services like FTP, emails, HTTP browsing or unicast video streaming (of 64 Kbits/sec) traffic. The MBMS session is set to start at the 110th second of the simulation. The simulation parameters used are provided in Table 4. The scenario has been simulated using the current 3GPP specified and our proposed MBMS handover algorithm respectively. The aim of this scenario is to

illustrate the link performance gain as well as the capacity gains that can be achieved on the unicast services in the central Point-to-Multipoint transmission mode cell when our proposed approach is applied. The results collected are presented, compared and analysed in section 3.7.2.3.

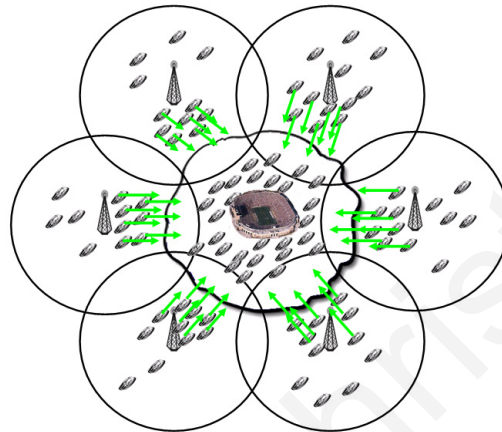

Figure 27 MBMS Handover control - Multi-cell Scenario 4

#### 3.7.1.4 Scenario 5

Scenario 5 shown in Figure 28 is used to illustrate the feasibility, the scalability and the capacity achievement of the proposed MBMS handover algorithm in multi-cell environment (closer to real cellular environments) where the inter-cell interference is increased. In this scenario groups of UEs are receiving an MBMS streaming video and set to move (in a pedestrian outdoor environment) with a speed of 6 Km/h from surrounding P-t-M transmission mode cells towards the central P-t-P transmission mode cell. The simulation parameters used are provided in Table 4. Three instances of the same scenario have been simulated using the current 3GPP specified and our proposed MBMS handover algorithm respectively:

- Instance 1: 6 MBMS users are moving towards the central cell
- Instance 2: 12 MBMS users are moving towards the central cell

- Instance 3: 18 MBMS users are moving towards the central cell

Results concerning the downlink transmission power requirements when the current 3GPP specified and our proposed handover approaches are applied, are collected, compared and analysed in section 3.7.2.4.

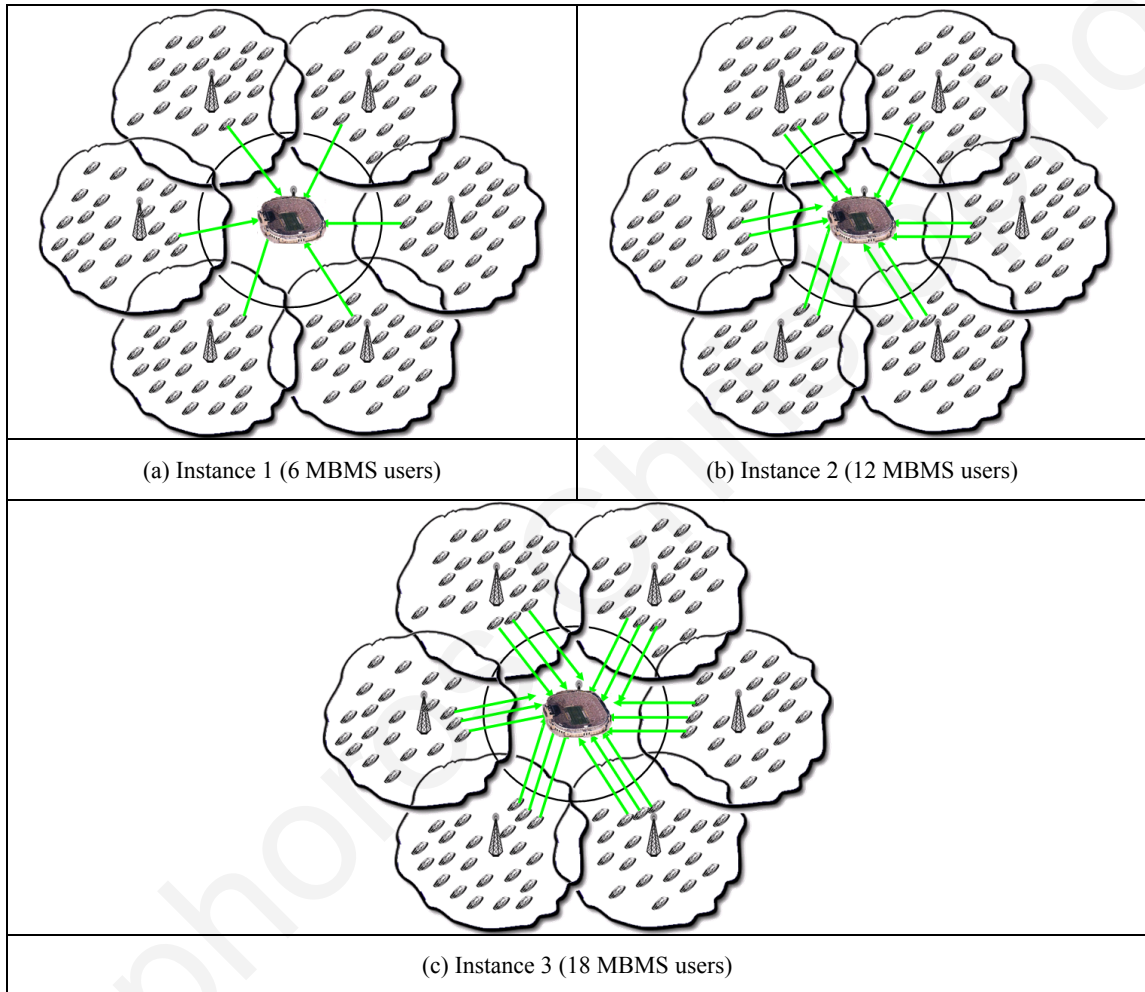

Figure 28 MBMS Handover control - Multi-cell Scenario 5

### 3.7.2 Analysis of Results

In this section the results collected from the scenarios described above are presented compared and analyzed.

### 3.7.2.1 Scenario 1 and Scenario 2

The results collected from the two instances of scenario 1 concerning the capacity (i.e., downlink transmission power) requirements in the P-t-P transmission mode cell when a pedestrian and a vehicular environment is used, are compared in Figure 29 and Figure 30, respectively.

As observed, the capacity gain that can be achieved in a pedestrian outdoor environment (see Figure 29) when our proposed handover approach is applied is significant; a substantial decrease (from 2.52 to 1.36 watts; see Figure 29.a) on the maximum downlink power required in the P-t-P transmission mode cell is observed (46 % decrease). This is achieved due to the ability of our proposed scheme to release the DCH established in the P-t-P transmission mode cell as soon as the FACH's signal quality (broadcast in the P-t-M transmission mode cell) becomes adequate to ensure the detection of the signal with the requested Bit Error Rate (BER). This results in the execution of the handover as close to the BS of the P-t-P transmission mode cell as possible, which reduces the demanded capacity in the P-t-P transmission mode cell to the minimum.

Moreover, the average downlink power required during the MBMS handover process (see Figure 29.b) is reduced from 1.183 to 0.413 watts (65% decrease), while the aggregated downlink power required (see Figure 29.c) is reduced from 2092 to 731 watts (1361 watts less).

Furthermore, the radio resources in the P-t-P cell are released much sooner (217 seconds sooner as depicted in Figure 29.a; at the 452<sup>nd</sup> second when our proposed approach is applied and at the 669<sup>th</sup> second when the current 3GPP specified approach is applied), thus making space for new admissions in the cell during these 217 seconds. Similar gains are achieved in the vehicular environment as well (see Figure 30).

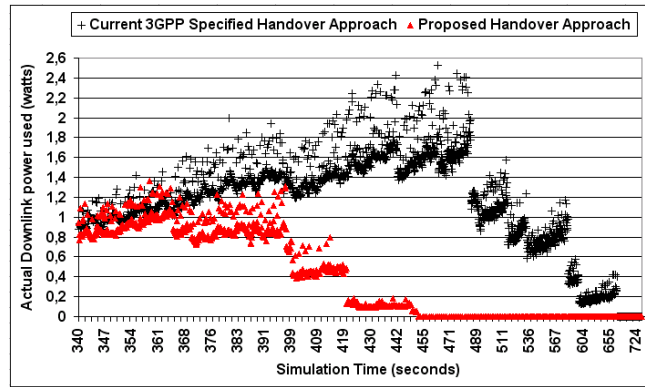

(a) Actual Downlink Power used in P-t-P transmission mode cell (watts)

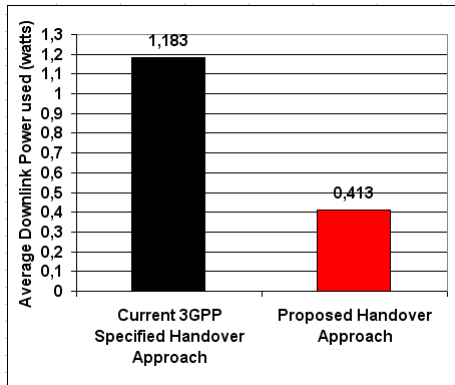

(b) Average Downlink Power used in P-t-P transmission mode cell (watts)

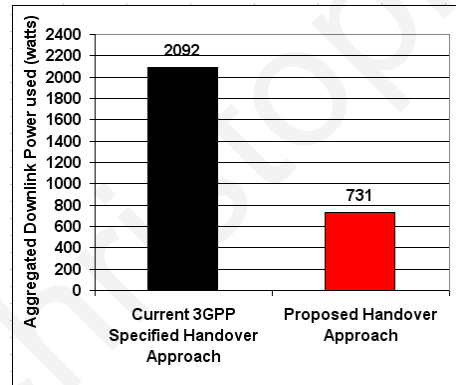

(c) Aggregated Downlink Power used in P-t-P transmission mode cell (watts)

Figure 29 MBMS Handover control - Scenario 1 Results: Pedestrian Environment (~6Km/h)

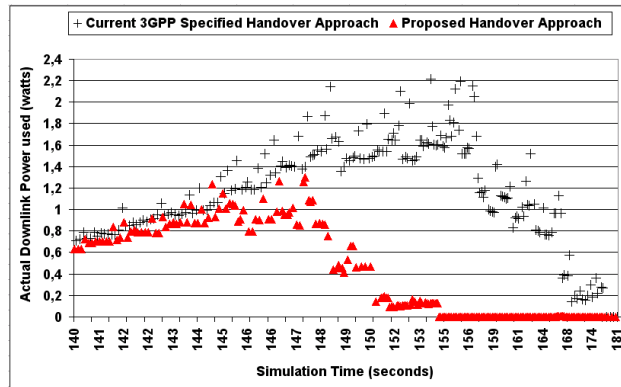

(a) Actual Downlink Power used in P-t-P transmission mode cell (watts)

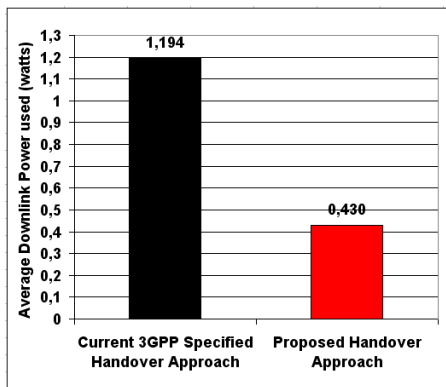

(b) Average Downlink Power used in P-t-P transmission mode cell (watts)

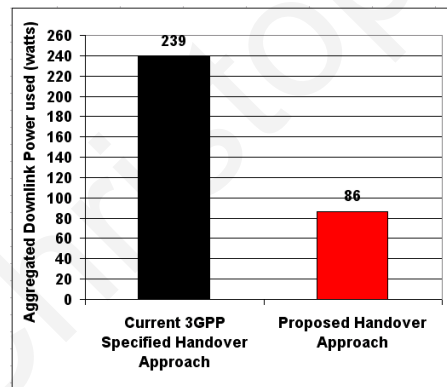

(c) Aggregated Downlink Power used in P-t-P transmission mode cell (watts)

Figure 30 MBMS Handover control - Scenario 1 Results: Vehicular Environment (~60Km/h)

The results collected from the two instances of scenario 2 concerning the capacity requirements in the P-t-P cell when a pedestrian and a vehicular environment is used, are compared in Figure 31 and Figure 32, respectively. Once again, the capacity gain that can be achieved in a pedestrian outdoor environment (see Figure 31) when our proposed MBMS handover approach is applied is significant; a substantial decrease (from 1.75 to 1.28 watts; see Figure 31.a) on the maximum downlink power used in the P-t-P transmission mode cell is achieved (27% decrease). This is achieved due to the ability of the proposed scheme to force the UEs to stay tuned to FACH as long as its signal strength is adequate for receiving the service with the required Bit Error Rate (BER). This results in the execution of the handover



as close to the BS of the P-t-P transmission mode cell as possible, which reduces the demanded capacity in the P-t-P transmission mode cell to the minimum.

Moreover, the average downlink power required (see Figure 31.b) during the MBMS handover process is reduced from 0.951 to 0.457 watts (52% decrease), while the aggregated downlink power required (see Figure 31.c) is reduced from 1370 to 659 watts (711 watts less).

Moreover, the radio resources in the P-t-P cell are allocated much later (166 seconds later as depicted in Figure 31.a; at the 578th second when the proposed scheme is applied and at the 412th second when the current 3GPP specified handover approach is applied), thus not causing additional interference in the P-t-P transmission mode cell during this period and giving space for other admissions. Similar gains are achieved in the vehicular environment as well (see Figure 32). The results presented above are also summarized in Table 5.

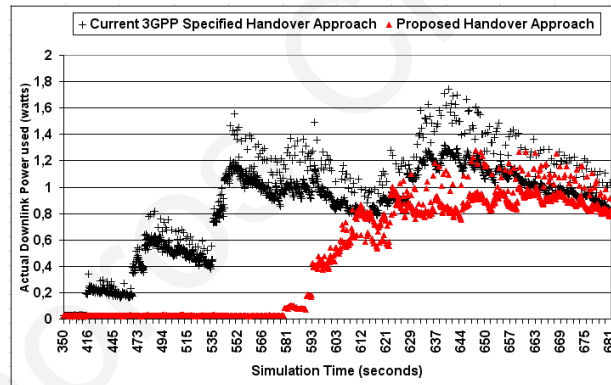

(a) Actual Downlink Power used in P-t-P transmission mode cell (watts)

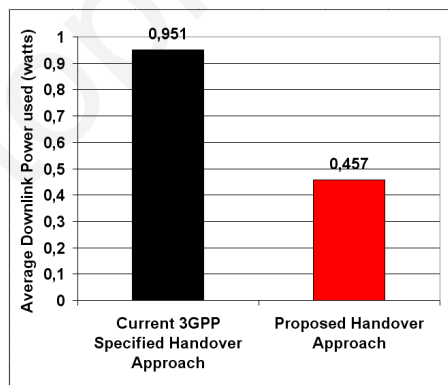

(b) Average Downlink Power used in P-t-P transmission mode cell (watts)

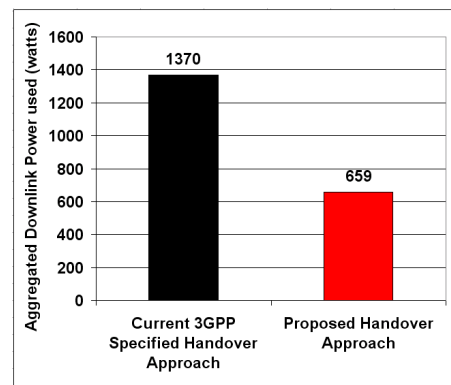

(b) Aggregated Downlink Power used in P-t-P transmission mode cell (watts)

Figure 31 MBMS Handover control - Scenario 2 Results: Pedestrian Environment (~6Km/h)

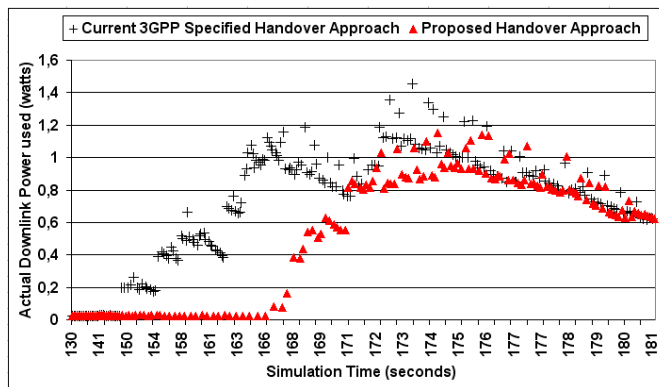

(a) Actual Downlink Power used in P-t-P transmission mode cell (watts)

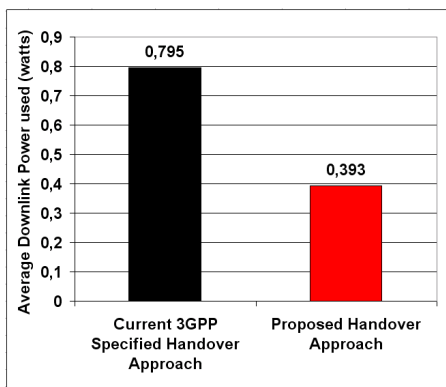

(b) Average Downlink Power used in P-t-P transmission mode cell (watts)

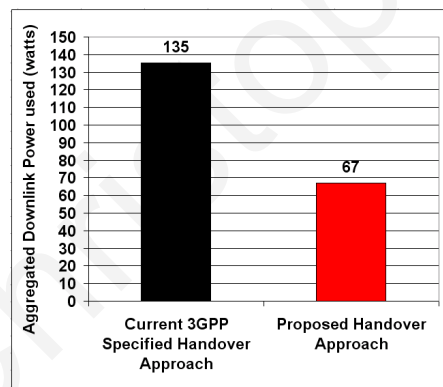

(b) Aggregated Downlink Power used in P-t-P transmission mode cell (watts)

Figure 32 MBMS Handover control - Scenario 2 Results: Vehicular Environment (~60Km/h)

Table 5 MBMS Handover Control - Scenario 1 and 2: Summary of the Results Presented

	Attribute	Current 3GPP Approach	Proposed Approach	Gain achieved
<b>Scenario 1</b> <i>From P-t-P to P-t-M</i> <b>Pedestrian Outdoor Environment</b>	<i>Max Downlink Power used</i>	2.52 watts	1.36 watts	<b>46% decrease</b>
	<i>Average Downlink power used</i>	1.183	0.413	<b>65% decrease</b>
	<i>Aggregated Downlink power used</i>	2092 watts	731 watts	<b>1361 watts less</b>
	<i>Resources Released in P-t-P Cell</i>	669 <sup>th</sup> sec.	452 <sup>nd</sup> sec.	<b>217 seconds sooner</b>
<b>Scenario 2</b> <i>From P-t-M to P-t-P</i> <b>Pedestrian Outdoor Environment</b>	<i>Max Downlink Power used</i>	1.75 watts	1.28 watts	<b>27% decrease</b>
	<i>Average Downlink power used</i>	0.951	0.457	<b>52 % decrease</b>
	<i>Aggregated Downlink power used</i>	1370 watts	659 watts	<b>711 watts less</b>
	<i>Resources Allocated in P-t-P Cell</i>	412 <sup>th</sup> sec.	578 <sup>th</sup> sec.	<b>166 seconds later</b>
<b>Scenario 1</b> <i>From P-t-P to P-t-M</i> <b>Vehicular Environment</b>	<i>Max Downlink Power used</i>	2.21 watts	1.29 watts	<b>42% decrease</b>
	<i>Average Downlink power used</i>	1.194	0.430	<b>64% decrease</b>
	<i>Aggregated Downlink power used</i>	239 watts	86 watts	<b>156 watts less</b>
	<i>Resources Released in P-t-P Cell</i>	154 <sup>th</sup> sec.	177 <sup>th</sup> sec.	<b>23 seconds sooner</b>
<b>Scenario 2</b> <i>From P-t-M to P-t-P</i> <b>Vehicular Environment</b>	<i>Max Downlink Power used</i>	1.45 watts	1.14 watts	<b>22% decrease</b>
	<i>Average Downlink power used</i>	0.795	0.393	<b>60 % decrease</b>
	<i>Aggregated Downlink power used</i>	135 watts	67 watts	<b>32 watts less</b>
	<i>Resources Allocated in P-t-P Cell</i>	147 <sup>th</sup> sec.	165 <sup>th</sup> sec.	<b>18 seconds later</b>

### 3.7.2.2 Scenario 3

The results collected from scenario 3 concerning the capacity (i.e., downlink transmission power) requirements in the P-t-P transmission mode cell and the QoS experienced by the MBMS users during the handover process, when the current 3GPP and our proposed MBMS handover control approach is applied are illustrated in Figure 33 and Table 6.

From the results collected, we observe that our proposed approach achieved the following gains:

- Significant transmission power savings (see Figure 33): By taking full advantage of FACH's capacity benefits (i.e., force the UE to stay tuned to the P-t-M transmission mode cell as long as the FACH signal strength is adequate for detecting the signal correctly and providing the required MBMS service's QoS), the maximum downlink power used in the P-t-P transmission mode cell is reduced from 3.66 to 2.35 watts

(that is 36% decrease; see Figure 33.a), the average downlink power used is reduced from 1.52 to 0.96 watts (that is 37% decrease; see Figure 33.b) while the aggregated downlink power used during the session is reduced from 3603 to 2269 watts (1334 watts less; see Figure 33.c).

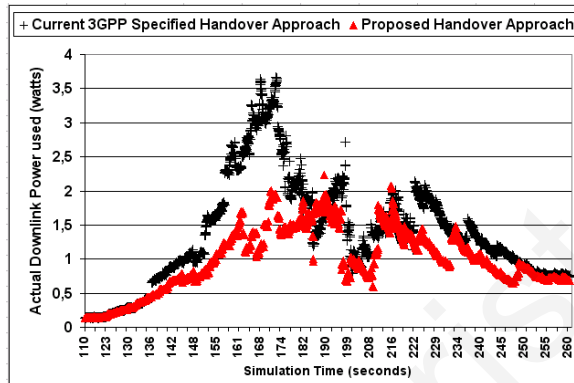

(a) Actual Downlink Power used in P-t-P transmission mode cell (watts)

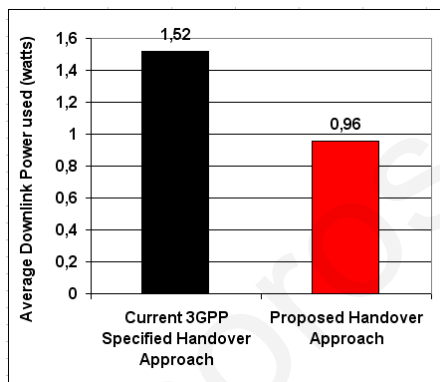

(b) Average Downlink Power used in P-t-P transmission mode cell (watts)

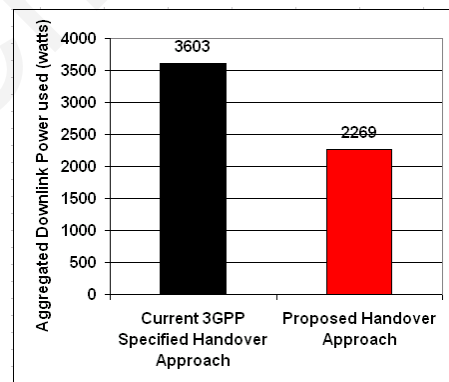

(b) Aggregated Downlink Power used in P-t-P transmission mode cell (watts)

Figure 33 MBMS Handover Control - Scenario 3 Results

- Seamless Handovers (see Table 6): By taking into consideration the FACH's bounded coverage range characteristic and executing the MBMS handover on the "Practical Handover Execution Point" (i.e., at a point exactly before the FACH signal quality becomes inadequate for detecting the signal correctly), managed to avoid any service interruption during the MBMS handover and support the QoS for all the MBMS users during the handover. Note that the minimum required CPICH  $E_c/N_0$  for guaranteeing

a reliable reception of the MBMS service using FACH is **-5dB**. As illustrated in Table 6, when the proposed MBMS handover control approach is applied, the measured CPICH Ec/No signal quality, after the handover's execution is greater than or equal to -5 dB for all the MBMS users. On the other hand, this is not achieved when the current 3GPP specified handover algorithm is applied (see Table 6 for UE's 6, 7, 12, 22, 23, 24, 26 and 29 shaded with gray).

Table 6 MBMS Handover Control – Scenario 3: QoS experienced

Current 3GPP Specified Handover Control Approach (measured in dB)											
UE 1	UE 2	UE 3	UE 4	UE 5	UE 6	UE 7	UE 8	UE 9	UE 10	UE 11	UE 12
-2.206	-4.477	+0.582	-1.957	-0.159	-6.254	-5.852	-2.206	-1.957	-4.094	-3.661	-8.284
UE 13	UE 14	UE 15	UE 16	UE 17	UE 18	UE 19	UE 20	UE 21	UE 22	UE 23	UE 24
-3.151	-4.478	-3.150	-1.455	-4.471	-2.204	-0.623	-1.985	-4.513	-8.633	-6.833	-6.239
UE 25	UE 26	UE 27	UE 28	UE 29	UE 30	<b>QoS NOT Supported for all MBMS users</b>					
-3.712	-8.892	-3.025	-4.373	-8.012	-4.146						
Proposed MBMS Handover Control Approach (measured in dB)											
UE 1	UE 2	UE 3	UE 4	UE 5	UE 6	UE 7	UE 8	UE 9	UE 10	UE 11	UE 12
-4.771	-4.982	-4.969	-4.896	-5.004	-4.989	-4.846	-4.980	-4.713	-4.377	-4.856	-4.902
UE 13	UE 14	UE 15	UE 16	UE 17	UE 18	UE 19	UE 20	UE 21	UE 22	UE 23	UE 24
-4.925	-4.978	-4.867	-4.942	-4.812	-4.795	-5.001	-4.757	-4.833	-4.809	-4.971	-4.868
UE 25	UE 26	UE 27	UE 28	UE 29	UE 30	<b>QoS Supported for all MBMS users</b>					
-4.857	-4.719	-4.957	-4.783	-4.940	-4.875						

### 3.7.2.3 Scenario 4

The results obtained from Scenario 4 (see Figure 34) concern the gain on the link performance improvement experienced by the users as well as the capacity gains (on the unicast services used) in the P-t-M transmission mode cell when our proposed MBMS handover approach is applied. This is achieved due to the ability of our proposed MBMS handover approach to reduce the transmission power requirements in the surrounding P-t-P transmission mode cells, which results in less inter-cell interference caused in the central P-t-

M transmission mode cell and thus better channel quality experienced and less transmission power requirements.

The function of the CPICH in a cell is to aid the channel quality estimation at the Terminal for the dedicated channel and to provide the channel quality estimation reference for the common channels. Figure 34.a illustrates the CPICH signal quality ( $E_c/N_0$ ) received by a UE near the P-t-M transmission mode cell's edge (~900 meters from the BS P-t-M) while Figure 34.b illustrates the CPICH signal quality ( $E_c/N_0$ ) received by a UE near the P-t-M transmission mode cell's BS (~200 meters from the P-t-M BS). As shown, when our proposed MBMS handover approach is applied, we can have up to 1.5 dB gain on the received channel quality for UEs near the P-t-M transmission mode cell's edge and up to 0.6 dB for UEs near the P-t-M transmission mode cell's BS.

Moreover, due to the reduction achieved on the inter-cell interference caused in the central Point-to-Multipoint transmission mode cell the transmission power required to support the UEs receiving unicast services have also been reduced. As illustrated in Figure 34.c, when our proposed MBMS handover approach is applied, the average downlink transmission power used for unicast services is reduced from 2.524 watts to 2.328 (i.e., 7.8% less transmission power used).

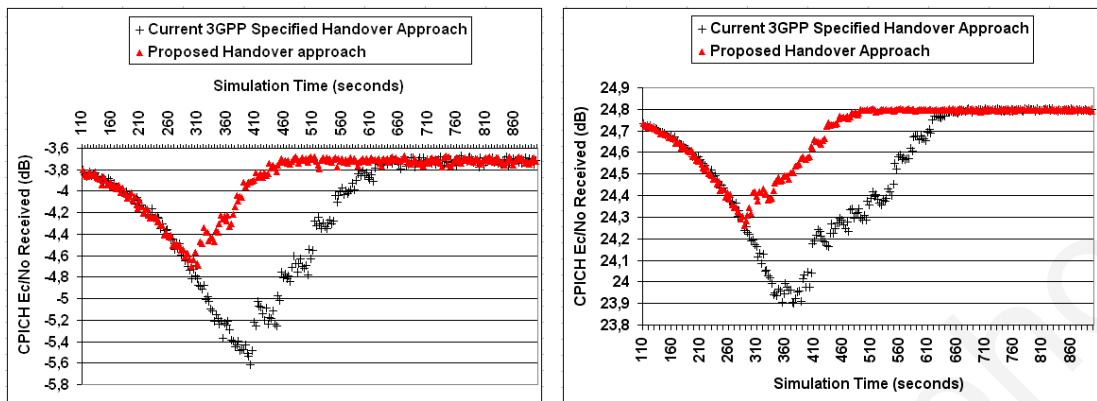

(a) Received channel quality in P-t-M transmission mode cell for UEs near the cell's edge (b) Received channel quality in P-t-P transmission mode cell for UEs near the cell's BS

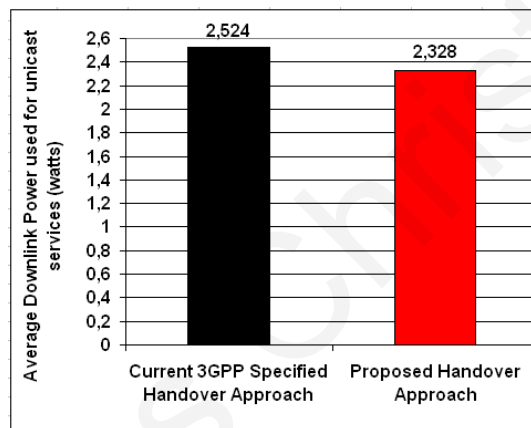

(c) Average Downlink Power used for unicast services in P-t-M transmission mode cell (watts)

Figure 34 MBMS Handover Control – Multi-cell Scenario 4 Results

### 3.7.2.4 Scenario 5

The results collected from the three instances of scenario 5 concerning the capacity (i.e., downlink transmission power) requirements in the P-t-P transmission mode cell when the current 3GPP and our proposed MBMS handover approach is applied in a multi-cell environment are presented in Figure 35.

In all Instances simulated for scenario 5, a significant decrease on the total downlink transmitted power has been observed when our proposed MBMS handover approach is applied.

For Instance 1 (6 MBMS users handing over into the central Point-to-Point transmission mode cell; see Figure 35.a) the maximum power used is reduced from 1.0 to 0.62 watts (38% decrease), while the average downlink power used is reduced from 0.42 to 0.18 watts (57% decrease).

For Instance 2 (12 MBMS users handing over into the Point-to-Point cell; see Figure 35.b) the maximum power used is reduced from 2.01 to 1.19 watts (41% decrease), while the average downlink power used is reduced from 0.78 to 0.37 watts (52% decrease).

For Instance 3 (18 MBMS users handing over into the Point-to-Point transmission mode cell) the maximum power used is reduced from 2.9 to 2.12 watts (27% decrease), while the average downlink power used is reduced from 1.31 to 0.75 watts (43% decrease).

Also, by comparing the results illustrated in Figure 35.b and Figure 35.c, we can observe that the average downlink power used by the current 3GPP specified handover approach in Instance 2 (0.78 watts to support 12 MBMS users; see Figure 35.b), is almost the same amount used by our proposed handover approach in Instance 3 (0.75 watts to support 18 MBMS users; see Figure 35.c). Thus, for the presented scenario, our proposed MBMS Handover scheme, by allocating the same amount of capacity, manages to support 6 more users (33% increase) than the current 3GPP specified approach.



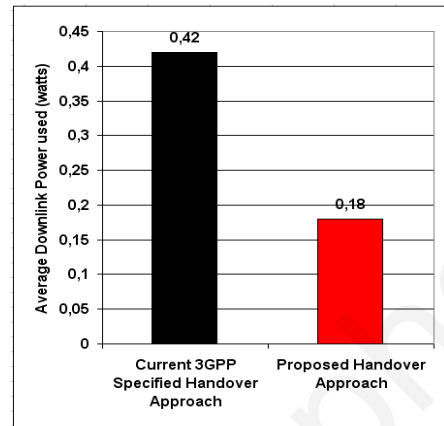
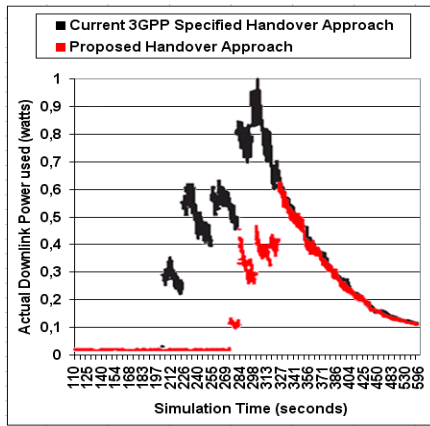

(a) Instance 1: Actual and Average Downlink Power used in P-t-P transmission mode cell (watts)

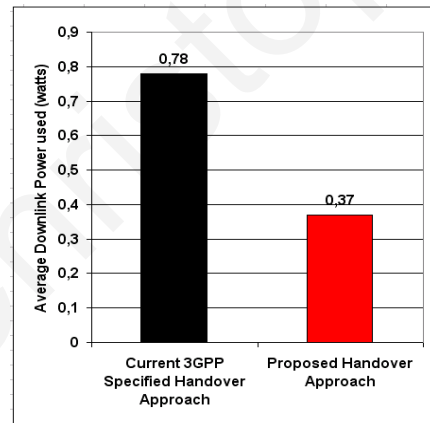
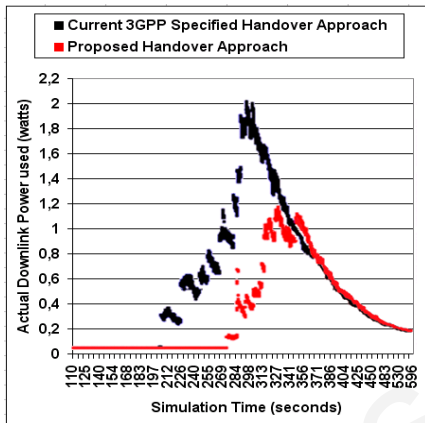

(b) Instance 2: Actual and Average Downlink Power used in P-t-P transmission mode cell (watts)

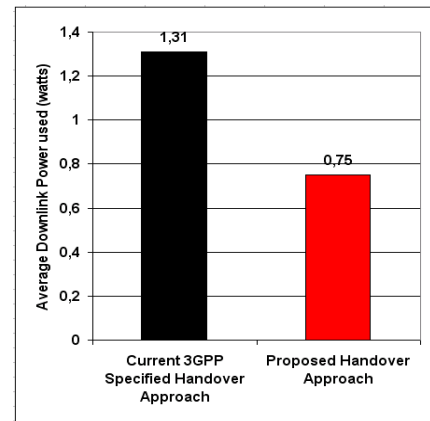
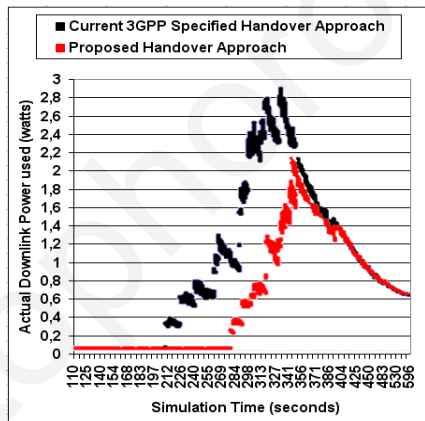

(c) Instance 3: Actual and Average Downlink Power used in the P-t-P transmission mode cell (watts)

Figure 35 MBMS Handover control – Multi-cell Scenario 5 Results

### 3.8 Concluding Remarks

In this chapter, we propose and evaluate a new MBMS handover control approach which efficiently deals with the new types of handovers introduced with MBMS, that is from P-t-P to P-t-M transmission mode cell and vice versa. By taking into consideration the FACH's capacity benefit and its bounded coverage characteristics, the aim of our proposed MBMS handover approach is to guarantee the MBMS service QoS and achieve increased system capacity and performance during an MBMS handover. This is accomplished by following a different approach than the current 3GPP specified handover control algorithm. Instead of having as the main input of the handover triggering the comparison of the CPICH Ec/No signal quality received from all the BSs that take part in the handover process, we consider only the CPICH Ec/No signal quality of the P-t-M transmission mode cell. This is a vital concern, since the main idea of our proposed MBMS handover approach is to reduce the transmission power required in the P-t-P transmission mode cells by taking full advantage of the capacity benefits that FACH (i.e. the P-t-M transmission mode cells) offers. The key in accomplishing this, is to find the handover triggering threshold value that will force the UE to stay tuned to FACH as long as its signal strength is adequate (in case the UE is handing over from a P-t-M to a P-t-P transmission mode cell), or tune to FACH as soon as its signal strength becomes adequate (in case the UE is handing over from a P-t-P to a P-t-M transmission mode cell), to guarantee the reception of the MBMS service with the required QoS.

By considering a number of dynamic parameters (i.e., CPICH Ec/No Alteration Rate, Pre-Trigger Predictor, Safety Margin, Activation Hysteresis, possibility  $p$  of an erroneous handover triggering to occur), which are influenced by the UE's movement, a threshold value (i.e., the Handover Trigger Threshold (HTT)) is dynamically estimated by our algorithm running in the UE. This threshold value is compared, during the UE's mobility, only with the CPICH Ec/No signal quality received from the P-t-M transmission mode cell and aims to facilitate an efficient MBMS handover triggering at a point that execution (i.e., switch from

DCH to FACH or vice versa) will be achieved as close to the BS of the P-t-P transmission mode cell as possible (in order to reduce the downlink transmission power requirements for the DCH) but not outside of the FACH supported area coverage limit (since outside of this area a QoS degradation is experienced).

Obviously, the “optimum” MBMS handover’s execution point achieving the aforementioned is the FACH supported area coverage limit of the P-t-M transmission mode cell. Note that this is the point where the FACH capacity benefits are fully exploited. However, achieving execution of the MBMS handover exactly on the “FACH supported area” coverage limit, is not so straightforward and also risky, due to the challenges imposed by the varying motion of the user and the varying signal fluctuations occurring during its mobility (mostly due to the effect of fast fading). Thus, in order to handle this issue and avoid any possibility for an erroneous handover triggering to occur, we introduced the *Safety Margin (SM)* parameter in the handover triggering decision, which dynamically regulates (only when necessary), the handover’s execution point by shifting it from the “FACH supported area” coverage limit slightly inside the “FACH supported area” guaranteed coverage area.

Using a series of representative scenarios simulated using our enhanced MBMS simulator (see Appendix C), we illustrated the importance of our proposed MBMS handover scheme on the overall system capacity, the link performance and the Quality of Service (QoS) when MBMS services are used. In particular, for the presented scenarios, we observed, during the MBMS handover process, a reduction in the average downlink capacity (i.e., downlink transmission power) required in the P-t-P transmission mode cells of up to 65%, a link performance improvement of up to 1.5 dB and also the ability of the proposed approach to avoid any QoS degradation during an MBMS handover. By using less downlink transmission power, less intra- and inter-cell interference is caused in the thus having additional benefits on the transmission power required for unicast services (about ~7.8% less power required for unicast services is observed).

As we have seen in the results presented, using the our proposed MBMS handover approach instead of the current 3GPP specified handover control algorithm when the mobile users have to deal with MBMS handovers can yield to considerable benefits. Since WCDMA is interference-limited this will reflect in an increase on the overall system capacity but also maintain a satisfactory call quality. In wireless/mobile environments where the radio resources are limited, any capacity increase and QoS improvement is of major importance, therefore the utility of the proposed approach for the MBMS system is evident.

## Chapter 4

### Efficient MBMS Service Provision in UTRAN

#### 4.1 Introduction

As currently specified by the 3GPP, MBMS (Multimedia Broadcast Multicast Service) bearer services can be provided within a cell either by Point-to-Point (P-t-P) or Point-to-Multipoint (P-t-M) transmission mode, **but not both at the same time**. In this chapter we highlight the inefficiencies that can be caused with this approach [2] and in order to address them and achieve efficient MBMS service provisioning, we motivate the need of allowing P-t-P (multiple DCHs) and P-t-M (one FACH) transmissions to coexist within the same cell, which we refer to as the “Dual Transmission mode cell”. The main idea of introducing this new type of cell in the MBMS service provisioning is to take full advantage of the benefits that both transmissions can offer (i.e., the capacity benefits of FACH and the fast power control of DCH) and achieve increased radio network capacity and performance. Then, we built on this idea and propose a new radio resource allocation algorithm to efficiently manage the radio resources of this new type of cell.

The proposed radio resource allocation algorithm, allows part of the cell’s area to be supported using FACH (“FACH supported area”) while the rest of it is supported using DCHs

("DCH supported area"). Both at session initiation and also periodically during the session, the algorithm notifies the MBMS users within the cell to report to the RNC their instantaneous context (i.e., indicate their location and movement within the cell which are both estimated using the CPICH Ec/No signal quality received from the serving cell as a reference). Then, the size of the FACH and DCH supported areas are dynamically adapted (shrink or expand by adapting the transmission power devoted to FACH and by releasing or establishing DCH connections), based on the instantaneous distribution and movement of the MBMS users within the cell, aiming to support, throughout the MBMS session, the requested Quality of Service (QoS) to all the MBMS users with the least amount of transmission power (i.e., capacity) consumption.

The context reporting request process is of extreme importance since if not treated with care, uplink congestion, increased uplink noise, increased terminal battery consumption, late decision making and redundant processing effort (in the RNC) is likely to occur. Thus, in order to further enhance efficiency and make our solution scalable we propose and integrate in our "Dual Transmission mode cell" approach, a new context reporting request process that performs the whole reporting request process in a more scalable fashion. That is, instead of notifying all the MBMS users within the cell to report at the same time (as done with all the other related approaches), the whole process is performed in consecutive steps; first the MBMS users that are close to the cell's edge are notified to report, then those that are further inside the cell and so on (note that the MBMS users that are close to the cell's edge are considered more "critical" to report, than those closer to the Node-B). By doing this the possibility of congestion in the uplink and also the uplink noise rise is reduced (especially in cases where a great number of MBMS users are present in the cell and all attempt to report at the same time). Moreover, the context reporting request process can be interrupted when further reporting is considered redundant. By doing this, the terminal battery life is increased (since we eliminate from the UEs the need of frequent reporting), the processing effort in the

RNC is reduced, and also faster radio resource allocation decision making is achieved (since less context reports are considered for the radio resource allocation decision).

Moreover, with the “Dual Transmission mode cell” approach we proposed in this chapter, mobility issues arise in terms of intra-cell handovers (i.e., handovers between the FACH and the DCH supported areas) that must be considered in order for this scheme to work efficiently. Thus, we also analyse these new types of handovers and propose a new handover algorithm to efficiently address them.

The chapter is organized as follows: In section 4.2 we describe related Radio Resource Management (RRM) schemes used for the MBMS service provisioning in UTRAN, which are most relevant with the particular research area. In section 4.3 the “Dual Transmission mode cell” concept is discussed. In section 4.4 the need for the “Dual Transmission mode cell” is motivated by emphasizing the gains that can be achieved, especially on the downlink capacity, compared to the current 3GPP specified MBMS service provision approach. The challenges we address in our design are discussed in section 4.5 and the problem is formulated in section 4.6. Our solution implementing the “Dual Transmission mode cell” concept is described in section 4.7 along with our new proposed context reporting request process. Also in the same section the mobility issues that arise with the “Dual Transmission mode cell” approach and the handover algorithm we propose to address them, are described. The performance evaluation of our proposed solution is presented in section 4.8, together with a comparative evaluation with competing approaches, such as “UE Counting”, “Power Counting”, “Rate Splitting”, and “FACH with Power Control”. Finally, in section 4.9 we provide some concluding remarks.

## **4.2 Related work**

From the surveyed literature, many schemes have been proposed for improving the MBMS service provisioning in UMTS. Below we briefly describe related Radio Resource

Management (RRM) schemes in UTRAN, which are most relevant with the particular research area.

Initially, as described by 3GPP and standardized in [2], the criterion used by the RNC for deciding how the MBMS service will be provided within the cell (i.e., either P-t-P or P-t-M transmission mode) was based on a “User Equipment (UE) Counting” threshold. The “UE Counting” threshold is predetermined based on the worst case scenario, i.e., all the UEs involved in the MBMS service are assumed to be at the cell’s edge. With this approach, the RNC, periodically and on a per cell basis, counts the UEs belonging to the same MBMS service. If the number of the counted UEs is lower than the “UE Counting” threshold then the P-t-P transmission mode is adopted in the cell, otherwise, the P-t-M transmission mode is adopted. The need for counting (see [8]) is indicated by the RNC by broadcasting a notification message to all the UEs belonging to the same MBMS service group. The UEs upon receiving this notification message respond to counting by sending dedicated Radio Resource Control (RRC) signalling to RNC. The counting response triggers RRC signalling and it is desirable to avoid that a large number of UEs in a specific cell respond to counting at the same time (due to Random Access Channel (RACH) congestion, etc). Therefore, UTRAN may also control the load due to the RRC signalling, by setting an access "Probability Factor (PF)" (see section 2.6.6). The RNC may use notification to indicate counting right before the MBMS session start or during an ongoing MBMS session (re-counting). In this way, a RRM decision algorithm can also command a switching between P-t-P or P-t-M connections with respect to changes that occur during the MBMS session (e.g., UEs enter or leave the cell or activate/de-activate the service).

The “UE Counting” is not the best possible approach because the current location of the UEs is not taken into account. Even in situations when UEs are static, this doesn’t necessarily mean that they are all located near the cell’s edge; i.e., the UEs could be located near the Node-B, thus resulting in significant transmission power waste if P-t-M transmission mode is used. Therefore, later a joint work [10] we performed during the B-BONE project [11] and



also standardized by 3GPP in [8], described a more efficient approach using the total amount of downlink transmission power required by each transmission mode as the transmission mode selection criterion. Based on this “Power Counting” approach, the RNC periodically and on a per cell basis, notifies all the UEs belonging to the same MBMS service to report to it the pathloss they experienced within the cell. Note that similarly to the “UE Counting” approach, UTRAN may also control the load of users that will attempt to report at the same time, by setting an access "Probability Factor (PF)" (see section 2.6.6). Based on the collected reports, the total amount of downlink transmission power required by each transmission mode is estimated and the most efficient one is adopted. The RNC may use notification to indicate reporting right before the MBMS session start or during an ongoing MBMS session. In this way, a RRM decision algorithm can also command a switching between P-t-P or P-t-M connections with respect to changes that occur during the MBMS session. Yet, with this approach significant transmission power waste is also caused if all the UEs are located near the cell's edge and P-t-M transmission mode is used (note that with this approach the power devoted to FACH during the P-t-M transmission mode is fixed and that much so as to cover the whole cell's area).

With the aforementioned approaches, the 3GPP pondered the performance of the FACH and they inferred that when P-t-M transmission mode is used (i.e. when MBMS content is carried over FACH) more than 30% of the Node-B's total power has to be allocated to a single 64 Kbps MBMS service, if full coverage is needed [7].

One way to improve the power efficiency of MBMS carried over FACH (i.e., during the P-t-M transmission mode) is to split the MBMS data stream into several streams with different Quality of Service (QoS). Using this Rate Splitting approach [12] [13], the lower layer (base layer) is coded by itself to provide the basic video quality and the enhancement layer is coded to enhance the lower layer. The lower layer is broadcast in the whole cell's coverage area while the enhancement layer is broadcast with less amount of power and only the users who have better channel conditions can receive it. The enhancement layer when

added back to the lower layer regenerates a higher quality reproduction of the input video. This way, transmission power for the most important stream can be reduced because the data rate is reduced, and the transmission power for the less important stream is also reduced because the coverage requirement is relaxed. However, the tradeoff is worsening QoS for UEs receiving only the base layer (see Figure 36), which is not desired (or fair) by the MBMS users. Exactly similar to the “Power Counting” approach, with the “Rate Splitting” approach, the RNC periodically and on a per cell basis, notifies all the UEs belonging to the same MBMS service to report to it the pathloss they experienced within the cell. The total downlink power required for each transmission mode is estimated (note that in this case the P-t-M transmission mode is established by setting up one FACH with half the bit rate to support the whole cell’s coverage and another FACH with half the bit rate to support a part of the cell’s area) and the most efficient one is adopted.

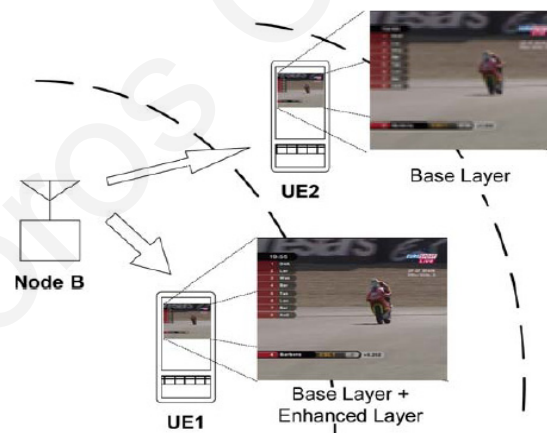

Figure 36 QoS received with Rate Splitting approach

FACH with Power Control is another approach, first proposed in [14] and later referenced in [15], that can be used for delivering MBMS services using FACH in a more efficient manner. With this approach, the transmission power devoted to FACH is determined based on the worst MBMS user’s pathloss. In order to reduce contention on RACH (due to context reporting of UEs in CELL\_FACH state), an absolute threshold value is set and have the users

report only when the CPICH  $E_c/N_0$  signal quality received becomes weaker than this value. By this way the transmission power devoted to FACH can be reduced (since the need of always having FACH covering the whole cell's area is eliminated), however the tradeoff is the need for very frequent and continual context reporting by the UEs (which results in increased terminal battery consumption and uplink noise) in order for the RNC to adjust the FACH's transmission power accordingly and thus avoid any QoS degradation. Moreover, this scheme results sometimes in redundant use of power since even if one UE is located near the cell's edge, full power should be devoted to FACH to support this UE.

All of the aforementioned approaches are based on the current 3GPP approach [2], which allows only one transmission mode to be utilized within a cell at any given time. The idea of allowing the "mixed usage of multiple DCHs channels and FACH" within the same cell was first appeared in a brief 3GPP report [15]. With this approach, some UEs lying within the inner part of the cell (i.e., those closer to the Node-B) can be served using a broadcast FACH channel while the rest of the UEs in the outer part (i.e., those near the cell's edge) can be served using DCHs. This idea was later suggested in [16] and [17] as an appealing method for providing MBMS services, since when a small number of UEs are in a bad position, there is no need to transmit large power for the broadcast FACH channel, and by using DCHs the power required to reach the "bad" UEs can be reduced, whilst the quality of the received stream can be maintained. However, to the best of our knowledge, we were the first to introduce a radio resource allocation algorithm specifically implementing this concept which appears in [18] - [21]. Thus, in this thesis we build on this "mixed usage of multiple DCHs channels and FACH" concept and propose a new radio resource allocation algorithm that by considering the instantaneous context of the cell (i.e., the way the UEs are distributed and moving within the cell) facilitates both at session initiation and also during the session an efficient (in terms of downlink network capacity and QoS) channel combination decision. Moreover, this new "Dual Transmission mode cell" concept introduces new mobility issues, in terms of inter- and intra-cell handovers, that we also analyse and address.

### 4.3 Dual Transmission mode cell concept

With the “Dual transmission mode cell” concept (see Figure 37) the group of users that join the same MBMS service is divided into two subgroups; the one subgroup will be served using FACH and the other subgroup using DCHs. The aim is to form the subgroups in such a way that the requested QoS is satisfied with the least amount of transmission power consumption. Based on these subgroups, the areas of the cell that will be supported using FACH (“FACH supported area”) and DCHs (“DCH supported area”) are decided and the appropriate channels (FACH and DCHs) are established and assigned to the MBMS users. During the session, in order to accommodate any changes that can occur on the cell’s context, mainly due to the mobility of the UEs, these subgroups are dynamically modified (by switching MBMS users from the DCHs’ subgroup to the FACH’s subgroup and vice versa), in order to always provide the MBMS service in the most efficient way (in terms of downlink network capacity and QoS). The modifications occurring during the session in the DCHs’ and FACH’s subgroups, will be reflected on the size of the “FACH supported area” and the “DCH supported area”, that will be dynamically adapted (shrink or expand) by reducing or increasing the transmission power devoted to FACH and by releasing or establishing DCH connections.

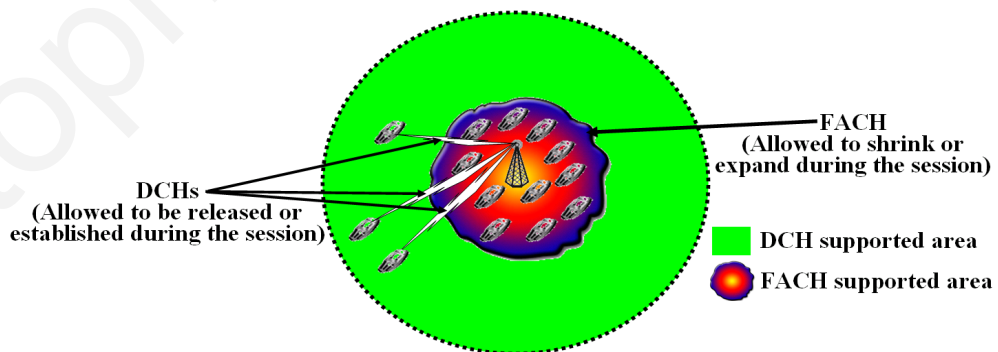

Figure 37 “Dual transmission mode cell” concept

#### 4.4 Motivation for “Dual Transmission mode cell” approach

In order to motivate the need for the “Dual Transmission mode cell” approach, the following simple scenario was investigated highlighting the capacity and processing effort gains (in the RNC and Node-B) that can be achieved with this scheme.

The scenario we use (Figure 38) considers the case where 30 stationary MBMS users, participating in a 3 minute duration 64 Kbits/sec MBMS streaming video session, are uniformly distributed at distances closer than 600 meters from the Node-B and two UEs (UE 1 and UE 2) located near the cell’s edge, are leaving and re-joining the MBMS service every 20 seconds. The simulation parameters used are provided in Table 7. Two instances of this scenario were simulated; one using the current 3GPP specified [2] and the other the “Dual Transmission mode cell” approach. Results concerning the capacity requirements and processing effort introduced by each approach were obtained using the UMTS model of OPNET Modeller 11.0.A.

Table 7 Simulation Parameters – Motivation for “Dual Transmission mode cell” scenario

Simulation Parameter	Value
Propagation environment	Pedestrian Outdoor
Cell radius	1000 meters
Node-B Antenna type	Omnidirectional
Shadow fading standard deviation	log-normal of 10 dB
Transmission Time Interval (TTI)	20 ms (as suggested in [43])
Channel coding	Convolutional 1/3 coding rate
Downlink Other-cell Interference factor	1.78
Thermal Noise power spectral density	-174 dBm
Orthogonality factor	0.5

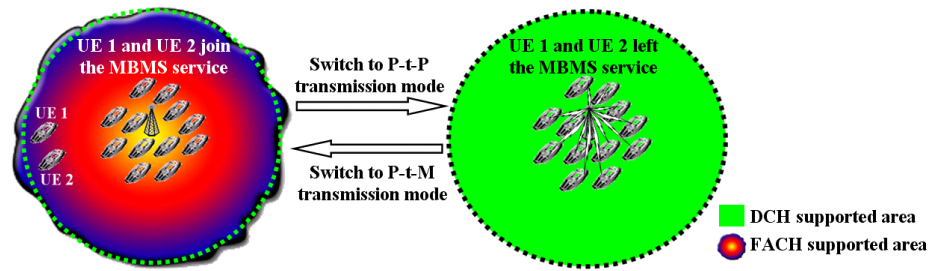

(a) Current 3GPP specified approach: Use either P-t-M or P-t-P transmission mode

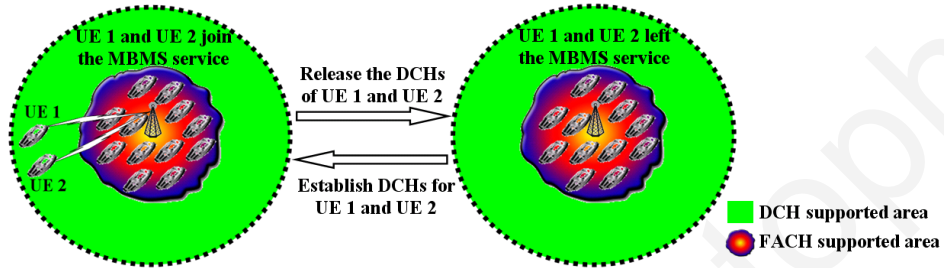

(b) "Dual Transmission mode cell" approach: Adapt FACH coverage to support the UEs near the Node-B and use DCHs for UEs near the cell's edge

Figure 38 Need for co-existence and dynamic adaptation of P-t-P and P-t-M transmissions

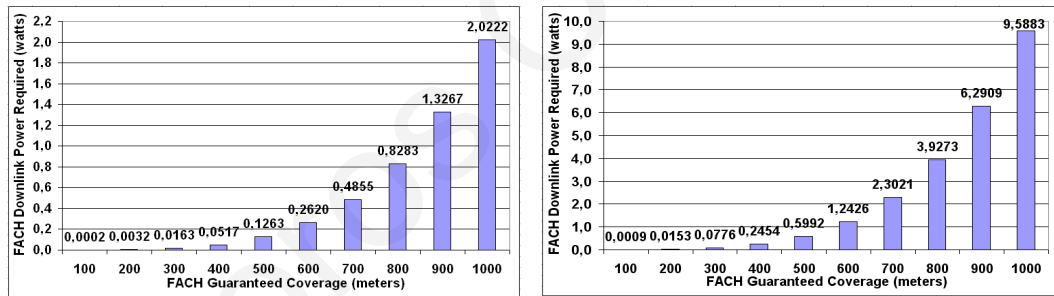

(a) FACH supported coverage area (meters) Vs Required Downlink power (watts) – 64 Kbits/sec

(b) FACH supported coverage area (meters) Vs Required Downlink power (watts) – 256 Kbits/sec

Figure 39 FACH transmission power required to cover a specific area of the cell

As illustrated in Figure 40 and Table 8, the gains that can be achieved on the capacity and processing effort efficiency when the "Dual transmission mode cell" approach is utilized are significant. Figure 39 analysing the power required to be devoted to FACH for supporting a specific coverage area of a cell further clarifies how these gains are achieved. The scenario we use is further analysed below.

At the initialization of the MBMS session, the current 3GPP specified approach (Figure 38.a), selects the P-t-M transmission mode as the most efficient to be adopted within the cell

and thus a FACH is established, allocating 2.0222 watts to cover the whole cell's area and support all the UEs within. On the other hand, the "Dual Transmission mode cell" approach (Figure 38.b) indicates that instead of using only one FACH to cover the whole cell, it is much more efficient to establish and dynamically adapt FACH's transmission power to 0.2620 watts in order to support the 30 UEs distributed at distance closer than 600 meters from the Node-B and use DCHs to support UE 1 and UE 2 located near the cell's edge (allocating a total of ~0.9 watts for both DCHs). By doing this, the total transmission power required is reduced from 2.0222 to ~1.162 watts (~33% less power; see Figure 40.a).

Furthermore, when UE 1 and UE 2 leave the MBMS service, the current 3GPP specified approach justifies the switching to P-t-P transmission mode causing the establishment of one DCH for each of the remaining 30 UEs (allocating a total of ~1.53 watts for all DCHs) and the releasing of the FACH. On the other hand, the "Dual Transmission mode cell" approach just releases the DCHs of UE 1 and UE 2 and maintains the FACH with transmission power of 0.2620 watts to support the 30 UEs near the Node-B. By doing this, the total transmission power required is reduced from 1.53 to 0.2620 watts (83% less power; see Figure 40.a).

When UE 1 and UE 2 join the MBMS service again, the 3GPP specified approach justifies the switching to P-t-M transmission mode causing the release of all the DCHs (30 in total) and the establishment of one FACH covering the whole cell's area (allocating 2.0222 watts). Then again, the "Dual Transmission mode cell" approach maintains the FACH with transmission power 0.2620 watts to support the 30 UEs near the Node-B and just establishes two more DCHs to support UE 1 and UE 2 near the cell's edge. By doing this, the total transmission power required is reduced from 2.0222 to 1.162 watts (33% less power; see Figure 40.a).

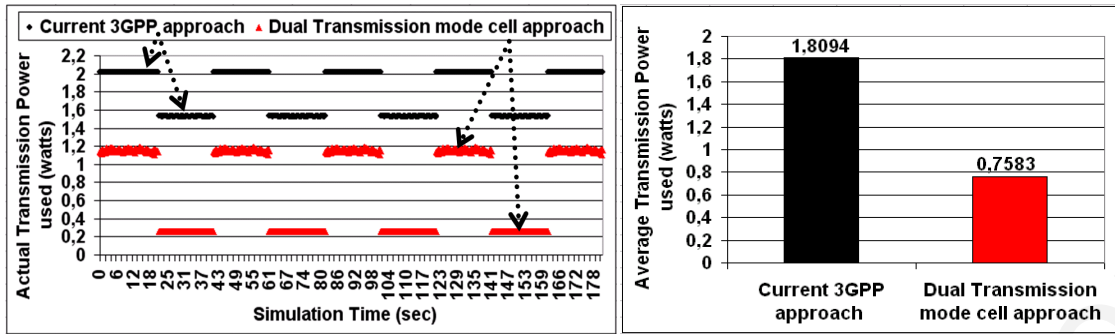

(a) Actual Transmission power used (watts)

(b) Average Transmission power used (watts)

Figure 40 Transmission power (capacity) requirements

The “Dual Transmission mode cell” approach, compared to the current 3GPP specified one, can achieve significant transmission power savings. As illustrated in Figure 40.b, the average transmission power used during the session is reduced from 1.8094 to 0.7583 watts (58% less). Moreover, the processing effort burdening the RNC and the Node-B, during the session, for the establishment or releasing of channels can also be considerably reduced (this is further analyzed in [19]). The aggregated processing effort introduced during the session by each approach is summarized and compared in Table 8.

Table 8 Aggregated Processing Effort Introduced in the RNC and Node-B

Current 3GPP specified approach		Dual Transmission mode cell approach	
Action	Times performed	Action	Times performed
Establish FACH	5	Establish FACH	1
Release FACH	4	Release FACH	0
Establish DCH	120	Establish DCH	10
Release DCH	120	Release DCH	8

The aforementioned highlights the potential gains that can be achieved with the “Dual Transmission mode cell” approach in the MBMS service provisioning. A vital aspect for achieving the gains illustrated above lies in the co-existence and dynamic adaptation of P-t-P and P-t-M transmissions during the MBMS session, a feature not considered in the current 3GPP specified approach [2] or the other related approaches in the literature.



#### 4.5 Main challenges of the proposed design

As indicated above, a vital aspect for achieving efficient MBMS service provisioning lies in the “Dual transmission mode cell”, which allows the co-existence and dynamic adaptation of DCH and FACH transmissions during the MBMS session. The main idea of introducing this new type of cell in the MBMS service provisioning is to take full advantage of the benefits that both transmission types can offer (i.e., the capacity benefits of FACH and the fast power control of DCH) and achieve increased radio network capacity and performance. Thus, by considering the characteristics of the FACH and DCH channels, analysed in section 2.6.5 of Chapter 2 we discuss below the main challenges in our design and the approach we adopt to address them and achieve the performance goal.

Based on the aforementioned, the main challenges in our design are to:

- Form and modify (during the MBMS session) the DCH and FACH subgroups in such a way that the benefits that FACH (capacity benefits) and DCH (fast power control) have, are fully exploited. The aim is to achieve a channel combination decision (i.e., decide which MBMS users should be served using FACH and which MBMS users should be served using DCH) that will provide the requested QoS to all the MBMS users with the least amount of transmission power (capacity) consumption.
- Consider the bounded coverage range of FACH and the capacity benefits that it can offer, in order to avoid any QoS degradation or any transmission power waste, during the mobility of the users within the cell.

To address these challenges, we propose two algorithms that run in parallel in order for the performance goal to be achieved. The first algorithm runs in the RNC and is responsible for the efficient formation and dynamic modification of the DCH and FACH subgroups, as well as the efficient management of the cell’s radio resources. It is worth noting that this algorithm cannot run continuously as this will cause excessive terminal’s battery consumption and uplink noise, due to the context reporting required to be received by the RNC from the

UEs. Thus, this algorithm needs to run periodically during the session. However, during idle periods any mobility of the users will not be accommodated, which may result in:

- **QoS degradation**, if a UE during this idle period moves from the “FACH supported area” to the “DCH supported area”. This will occur since the transmission power allocated to FACH is at a level aimed to ensure the requested QoS only throughout the specified “FACH supported area”. Thus once outside of this area, the signal strength of FACH will start degrading and be inadequate for the UE to decode the signal correctly.
- **Transmission power waste**, if a UE during this idle period moves from the “DCH supported area” to the “FACH supported area”. This will occur since the UE will continue receiving the service using DCH in an area where the service is also reliably supported using the FACH already established in the cell. Thus in this case the DCH connection should be broken earlier, in order to release the additional transmission power allocated for it and save some capacity for other admissions.

Hence, the role of the second algorithm is to complement the first one during these idle periods of time. This algorithm runs in the UEs and is responsible for monitoring and efficiently executing an intra-cell handover between the FACH and DCH supported areas and therefore lessen the possibility of the aforesaid inefficiencies to occur.

Below we formulate our problem, and then propose a practical algorithm to solve it. The proposed radio resource allocation algorithm along with the handover algorithm addressing the mobility issues, are described in detail in section 4.7.

#### **4.6 Problem formulation**

Assume a cell  $C$ . Within the cell there exist  $N$  users whose locations remain static for the time of interest. Area  $A$  is a subarea of the cell which will be supported by using FACH (see Figure 41). This area does not normally provide a homogeneous coverage. Since fast power

control cannot be applied on FACH, the different channel impairments<sup>6</sup> that degrade the signal quality during propagation cannot be efficiently compensated, resulting in non-homogeneous dispersion of the signal quality along the perimeter of the selected area  $A$ , with also as a result its coverage range bounded. Hence outside of area  $A$  the requested QoS cannot be reliably supported using FACH.

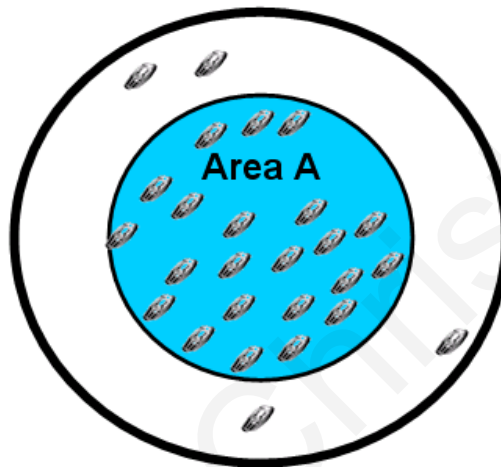

Figure 41 Dual Transmission mode cell – Problem formulation

Due to the non-homogeneous dispersion of FACH's signal quality within the cell, the actual location of the user cannot be considered as a reliable criterion to indicate if the user lies within the area  $A$ . Thus, the criterion we adopt to indicate if a user lies within the area  $A$ , is not his distance from the Node-B but the Common Pilot Channel (CPICH)  $E_c/N_0$  signal quality he receives. Hence, the way the users are distributed within the cell is defined based on the channel quality they receive within the cell (i.e., "channel quality" based distribution).

Therefore, in order to ensure that we provide adequate QoS support to those users that will be served by FACH, we assume that a user  $u_i$ ,  $i \in \{1, 2, 3, \dots, N\}$ , lies within the area  $A$  if  $u_{i\_CPICH} \geq Q$  dB. Where  $u_{i\_CPICH}$  is the CPICH  $E_c/N_0$  signal quality received by  $u_i$  from the

---

<sup>6</sup> The channel impairment can be due to for example the distance dependent path loss, the location dependent shadowing, multi-path fading dependent on the speed and environment of the mobile, and the interference level dependent on cell position and neighbouring cell activity.

serving cell. Note that the value  $Q$  defines the coverage limit of this area  $A$ . In this way, the area  $A$  determines the  $m$  number of users served by FACH and satisfying their QoS, while the remaining  $N-m$  number of users are served by DCH, with their QoS also satisfied. So  $m$  is a function  $f(\cdot)$  of the area  $A$  such that  $m = f(A)$ .

Our objective is to determine the area  $A^*$  that will be supported using FACH, such that it minimises the total downlink transmission power consumption. This optimal area  $A^*$  will determine the  $m$  number of users that will utilize FACH. Let  $P_{DL}(N, x, A)$  denote the total downlink transmission power required for a given number  $N$  of users in the cell, for a given distribution  $x$  of the users within the cell and a given FACH subarea of the cell  $A$ . Note that the total downlink power comprises the fixed component of the power required by the FACH to support the  $m$  number of users within area  $A$ , plus the total power required for the  $N-m$  number of users using DCHs, which is dependent on the given distribution  $x$ .

The objective can thus be expressed mathematically as follows:

$$A^* = \arg \min_A P_{DL}(N, x, A) \quad \text{(Problem 1)}$$

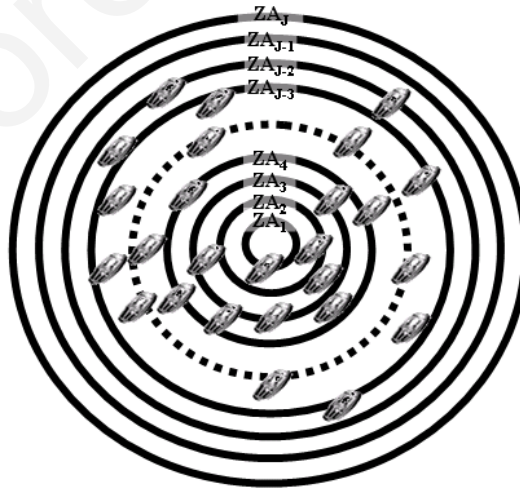

Figure 42 Dual Transmission mode cell – Introduction of Zone Areas

The infinite space of the area  $A$ , makes the above problem extremely difficult to solve. To render the problem tractable, we discretize area  $A$  by introducing the idea of the Zone Areas

(ZAs), which are subareas of the cell  $C$  (see Figure 42). We divide the cell into a number  $J$  of zones areas  $ZA_j, j \in \{1, 2, 3, \dots, J\}$ , such that  $\bigcup_{j \in J} ZA_j = C$ . A user  $u_i, i \in \{1, 2, 3, \dots, N\}$ , lies within the  $ZA_j$  if  $u_{i\_CPICH} \geq Q_j$  dB. For each zone area  $ZA_j, j \in \{1, 2, 3, \dots, J\}$ , we calculate the total downlink power consumption  $P_{DL}(N, x, ZA_j)$  (i.e., the total downlink power required by the FACH to support the  $m$  number of users within  $ZA_j$ , plus the total power required to support the rest  $N-m$  number of users using DCHs) and we consider a relaxation of Problem 1 given by:

$$A^{**} = \arg \min_{ZA_j, j \in J} P_{DL}(N, x, ZA_j)$$

In this way, the selected  $ZA_j$  determines the  $m$  number of users served by FACH, while the remaining  $N-m$  number of users are served by DCH.

To solve this problem we provide a solution approach next.

#### 4.7 Proposed Radio Resource Allocation Algorithm

Motivated by the problem formulation presented above, we develop a heuristic approach (algorithm) to solve the problem, also considering the users' mobility. The proposed radio resource allocation algorithm aims to efficiently form (at session initiation) and modify (during the session) the subgroups of users that will be served by DCH and FACH, in such a way that the requested QoS is always supported, with the least amount of transmission power consumption. However, due to the mobility of the users within the cell, this procedure is not straightforward, especially with QoS inefficiencies likely to occur for those users that are located near the "FACH supported area" coverage limit.

Thus, before these subgroups are formed, it is vital for the algorithm to be informed not only about the way the users are distributed, but also it is important to know how the users are moving within the cell (both will be estimated using the CPICH  $E_c/N_o$  signal quality

measured from the serving cell as a reference). Using this knowledge, the algorithm forms different possible combinations of group of MBMS users that should be served using FACH and DCH (we refer to these different possible combinations as Transmission Arrangements (TAs); see section 4.7.1.1.2), which can be used for the MBMS service provisioning. Then, the transmission power required for each is estimated and the most efficient, among these combinations of groups, is selected and adopted.

#### 4.7.1 Description of the algorithm

Based on the aforementioned, we divide the proposed radio resource allocation algorithm into two phases:

- **Initialization phase:** Just before the MBMS session starts, based on the instantaneous context of the cell (i.e., the way the MBMS users are distributed and moving within the cell), the transmission arrangement that will be used for the initialization of the MBMS session is selected, the size of the “FACH supported area” and “DCH supported area” is decided, the required radio resources are allocated and the appropriate channels (FACH and DCHs) are established and assigned to the MBMS users.
- **MBMS Session Ongoing phase:** During the session, a lot of changes can occur that can influence the context of the cell. For example, during the session, MBMS users might enter or leave the cell, move from the “FACH supported area” to the “DCH supported area”, or vice versa (i.e. perform an intra- cell handover), join or leave the MBMS service, or even move within the cell. Thus, periodically (*period T*) during this phase, the Transmission Arrangement used is dynamically modified in order to accommodate these changes and provide the MBMS service as efficiently as possible.

Moreover, each phase described above is executed in three steps:

- **Information Collection step:** In this step, all the necessary context information that provides to the algorithm the instantaneous context of the MBMS users (those that

joined the same MBMS service) within the cell, is collected, processed and stored locally in the RNC.

- **Transmission Arrangements Estimation step:** In this step, the algorithm, having as input all the context information acquired during the Information Collection step, forms all possible Transmission Arrangements that can be used for the MBMS service provision (note that these Transmission Arrangements are formed in such a way that the requested QoS is guaranteed for all the MBMS users) and estimates the total amount of capacity required for each.
- **Final Decision step:** In this step, the algorithm selects, among all possible Transmission Arrangements formed, the most efficient one and adopts it.

Below we provide the details of each phase of the algorithm. To simplify the description, we assume a one-cell scenario. In case of a multi-cell scenario, the actions described below will occur in each cell that the MBMS service is made available.

#### **4.7.1.1 Initialization phase**

The steps executed during this phase are described in the following subsections.

##### **4.7.1.1.1 Information Collection Step**

In order for the algorithm to form the possible Transmission Arrangements that can be used within the cell at the initialization phase of the MBMS service, it first needs to become aware of how the MBMS users who joined the specific MBMS service are distributed and moving within the cell. Therefore, just before the MBMS session starts, the RNC creates for the cell a “Cell Context Information Table (CCIT)” (see Table 9) in which the instantaneous context of the MBMS users moving within the cell (and who have joined the specific MBMS service) will be stored. Then, the RNC starts the context reporting request process (see section 4.7.2) in order to acquire the instantaneous context of the MBMS users and depict an image of how they are distributed and moving within. The context report that the UEs will send must include the following information:

- CPICH Ec/No signal quality received from serving cell (1 byte)
- CPICH Ec/No alteration rate experienced from serving cell (1 byte)

Also, if the MBMS user is located near the cell's edge (i.e., if the received CPICH Ec/No signal quality of the serving cell is weaker than a threshold value indicated by the RNC), and thus a handover to the best neighbouring cell might be required, this report will also include:

- Best Neighbouring cell's ID (2 bytes)
- CPICH Ec/No signal quality received from Best Neighbouring cell (1 byte)
- CPICH Ec/No alteration rate experienced from Best Neighbouring cell (1 byte)

The context reporting request process is of extreme importance since if not treated with care, uplink congestion, increased uplink noise, increased terminal battery consumption, late decision making and redundant processing effort (in the RNC) is likely to occur. Thus, in order to achieve efficiency of the aforementioned factors we treat the context reporting request differently than the other related approaches described in section 4.2. The new context reporting request process we propose [21] and adopt for collecting the instantaneous users' context is described in detail in section 4.7.2.

For each MBMS user from which a context report is received, the RNC creates one record in the CCIT and stores the context information included. It is worth mentioning here that at the end of the Information Collection step, the CCIT will not necessarily include one record for each MBMS user within the cell (see section 4.7.2). However, it will include enough context information that will facilitate the algorithm to form and select the Transmission Arrangement that will provide the required QoS to all the MBMS users with the least amount of transmission power (i.e., capacity) consumption.



Table 9 Cell Context Information Table (CCIT)

Cell's ID (Uniquely identifying the Cell that this CCIT belongs to)								
MBMS TMGI (Uniquely identifying the MBMS Service that this table is created for)								
MBMS Service QoS Requirements (QoS Class, Bit Rate, Delay, Loss)								
QoS ID (The MBMS QoS Requirements are mapped into a QoS ID)								
Zone Area supported using FACH								
MBMS users' records	UE_1 IMSI	CPICH Ec/No signal quality	CPICH Ec/No alteration rate	Power required for DCH	Channel assigned	Best Neighbouring Cell Information *		
						Cell's ID	CPICH Ec/No signal quality	CPICH Ec/No alteration rate
	UE_2 IMSI	CPICH Ec/No signal quality	CPICH Ec/No alteration rate	Power required for DCH	Channel assigned	Best Neighbouring Cell Information *		
						Cell's ID	CPICH Ec/No signal quality	CPICH Ec/No alteration rate
.....								
* Information is stored in these fields only if the user is likely to handover to a neighbouring cell (i.e. the MBMS user is located near the serving cell's edge)								

The fields included in the Cell Context Information Table (CCIT) are described below:

- **Cell ID:** Uniquely identifies the cell for which this CCIT is created for (**2 bytes**)
- **MBMS TMGI (Temporary Mobile Group Identity):** Uniquely identifies the MBMS service for which this CCIT is created for. For each MBMS service that can be available within the cell, one CCIT is created. Note that the TMGI is allocated globally by the BM-SC and is composed of a local MBMS bearer service identity having a size of three octets, or bytes, as well as well as a Public Land Mobile Network (PLMN) identity of the PLMN to which the BM-SC belongs. The TMGI is equivalent to the IP multicast address and Access Point Name (APN) pair, and is used for an efficient identification of the employed MBMS bearer. The TMGI is transmitted to the UE during the MBMS session activation for multicast sessions or during service announcement for broadcast sessions (**it may be 70 bytes long or more**)
- **MBMS Service QoS Requirements:** Here the QoS requirements of the MBMS service, in terms of QoS class (i.e. conventional, streaming, interactive, background), bit rate, delay and loss, are indicated (**4 bytes**).

- **QoS ID:** The QoS requirements of the MBMS service will be mapped into a QoS ID. Note that different MBMS services with the same QoS requirements are mapped into the same QoS ID. This QoS ID will be later considered by the RNC for estimating the transmission power required for each Transmission Arrangement and also for indicating and providing the appropriate thresholds that will be used by the UEs for handover purposes (see section 4.7.4.2) (1 byte).
- **Zone Area supported using FACH:** Once the Transmission Arrangement that will be adopted in the cell is selected, the Zone Area (i.e., the part of the cell) that will be supported using FACH is indicated here (1 byte). This information will then be considered in order to broadcast the related parameters that will be used by the UEs for intra-cell handover purposes (see section 4.7.4.2).
- **MBMS users' records:** Each MBMS user's record includes the following:
  - **UE's IMSI** (International Mobile Subscriber Identity): Uniquely identifying the user (9 bytes).
  - **CPICH Ec/No signal quality received:** The role of the CPICH is to be used by the UE for dedicated channel (i.e., in this case the DCH) quality estimation and to provide channel quality estimation reference when common channels (i.e., in this case FACH) are involved. Thus, this value will indicate the instantaneous channel quality received by the MBMS user within the cell. By knowing for each MBMS user the channel quality received, the algorithm becomes aware of the MBMS users' distribution within the cell. Recall that the criterion we adopt indicating how the MBMS users are distributed is not their distance from the Node-B but the CPICH Ec/No signal quality they receive (i.e., "channel quality" based distribution) (1 byte).
  - **CPICH Ec/No alteration rate experienced:** Indicates for each MBMS user, how fast the channel quality degrades or improves during its mobility within the cell. By knowing for each MBMS user the channel quality alteration rate

experienced, the algorithm becomes aware of the MBMS users' movement within the cell (i.e., "channel quality" based movement) (1 byte).

- **Power required for DCH:** Can either be reported from the Node-B to the RNC by means of NBAP (Node-B Application Protocol) dedicated report (in case the MBMS user receives the service using DCH) or estimated by the RNC using existing protocols (i.e., by using the downlink open loop power control equation for estimating the initial downlink power for a DCH) based on the CPICH Ec/No value reported by the MBMS user (in case the MBMS user receives the service using FACH) (1 byte).

$$P_{DCH} = \frac{R \times (Eb/No)_{DL}}{W} \times \left( \frac{CPICH\_Tx\_Power}{CPICH\_Rx\_Ec/No} - \alpha \times P_{Car} \right)$$

Where:

- *R* is the MBMS Service bit rate
  - *(Eb/No)<sub>DL</sub>* is the DL planned Eb/No value set for achieving a certain Bit Error Rate (BER) so as to satisfy the required QoS
  - *W* is the chip rate (3.84 Mcps)
  - *CPICH\_Rx\_Ec/No* is the measurement report received from UE
  - *CPICH\_Tx* is the initial CPICH transmission power used by the Node-B
  - *α* is the orthogonality factor
  - *P<sub>Car</sub>* is the total carrier power measured at the Node-B and reported to the RNC
- **Channel Assigned:** Set to DCH or FACH based on the Transmission Arrangement selected; "DCH" if the user will be supported using DCH; "FACH" if the user will be supported using FACH (1 bit).
  - **Best neighbouring cell's information:** The following context information will be reported only in case where the MBMS user is located near the serving cell's edge and thus an inter- cell handover might be required:
    - Best Neighbouring Cell's ID (2 bytes)
    - Best Neighbouring Cell's CPICH Ec/No signal quality (1 byte)
    - Best Neighbouring Cell's CPICH Ec/No Alteration Rate (1 byte)

#### 4.7.1.1.2 Transmission Arrangements Estimation step

Upon completion of the Information Collection step, the CCIT will provide to the algorithm the context information required that will assist it to form the possible Transmission Arrangements that can be used for the MBMS service provision within the cell. However, in order to do that and also estimate the transmission power required for each, the algorithm also needs to know the transmission power that should be devoted to FACH for guaranteeing a reliable reception of the MBMS service at different distances from the cell's Node-B (referred to as different "Zone Areas"; see Figure 43). As mentioned earlier, the Zone Areas (ZAs) are introduced in order to make the optimization problem tractable. This info will be pre-estimated by the Network Operator during Radio Network Planning and provided to the RNC, in a form similar to that shown in Table 10. We refer to this table as "FACH Information Table (FACH\_IT)".

Table 10 FACH Information Table (FACH\_IT) – 64 Kbps MBMS Streaming Video

Cell ID (Identifying the Cell this FACH_IT belongs to)		
QoS ID (Associating the FACH_IT with the MBMS service's QoS requirements)		
Zone Area	Zone Area coverage limit CPICH Ec/No required to be received	FACH transmission power required to reliably support the Zone Area
ZA1 (~100m coverage)	$\geq 35\text{dB}$	0.0002 watts
ZA2 (~200m coverage)	$\geq 21.5\text{dB}$	0.0032 watts
ZA3 (~300m coverage)	$\geq 14\text{dB}$	0.0163 watts
ZA4 (~400m coverage)	$\geq 9\text{dB}$	0.0517 watts
ZA5 (~500m coverage)	$\geq 5\text{dB}$	0.1263 watts
ZA6 (~600m coverage)	$\geq 1.8\text{dB}$	0.2620 watts
ZA7 (~700m coverage)	$\geq -0.9\text{dB}$	0.4855 watts
ZA8 (~800m coverage)	$\geq -3.3\text{dB}$	0.8283 watts
ZA9 (~900m coverage)	$\geq -5.4\text{dB}$	1.3267 watts
ZA10 (full cell coverage)	$\geq -7.2\text{dB}$	2.0222 watts

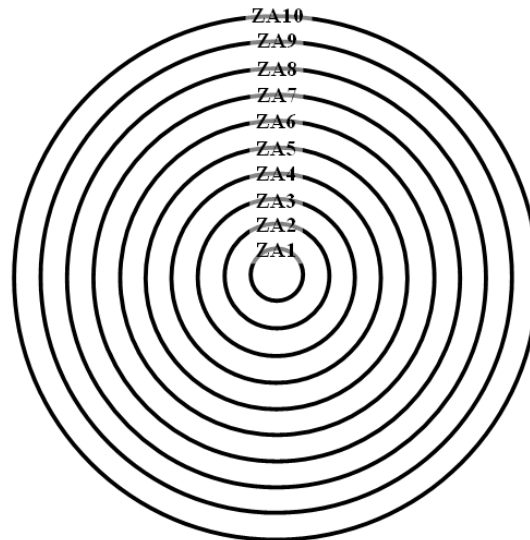

*Figure 43 Cell with radius 1000 meters divided into 10 Zone Areas*

In the FACH\_IT example shown above, created for a 64 Kbits/sec MBMS streaming video, we divided a cell with radius 1000 meters into ten Zones Areas (ZA1 – ZA10). Note that dividing the cell into ten ZAs, in this example, is just to simplify the description of the algorithm. In reality, the cell can be divided up to many more ZAs, for example 200, if the Network Operator desires this. The coverage limit of each ZA is defined based on a minimum CPICH  $E_c/N_0$  signal quality value required to be received by the UE for guaranteeing a reliable reception of the MBMS content using FACH. Note that the values included in the FACH\_IT shown above, were acquired using OPNET Modeller 11.0.A, assuming a 0.01 Block Error Rate (BLER) target, a low load pedestrian outdoor environment, a log-normal shadow fading of 10dB, a Transmission Time Interval (TTI) length of 20ms and a convolutional channel coding with 1/3 coding rate. The transmission power allocated to CPICH is 2 watts. The downlink other-cell interference factor (i.e., the ratio of the inter-cell interference to the total power received from the own cell in the downlink) is set to 1.78 (which is the default value set by OPNET).

Having Table 10 as a reference, if the MBMS user receives the CPICH  $E_c/N_0$  with greater than or equal to ( $\geq$ ) 35dB then it belongs to Zone Area 1 (ZA1); if the MBMS user receives the CPICH  $E_c/N_0$  with greater than or equal to ( $\geq$ ) 21.5 dB then it belongs to Zone

Area 2 (ZA2), etc. Note that the MBMS users that belong to ZA1 also belong to ZA2, MBMS users that belong to ZA1 and ZA2 also belong in ZA3, and so on. Since in one cell more than one MBMS services with different QoS requirements can be made available, one FACH\_IT will be created for each group of MBMS services that have the same QoS requirements and will be uniquely identified using the Cell's ID and the QoS ID mapped to these QoS requirements.

It is worth indicating here that the reason for associating an MBMS service with a QoS ID is to reduce the number of the FACH\_ITs required to be stored in the RNC. For example, instead of creating one FACH\_IT for each MBMS service that can be made available in the cell (which can be unlimited), we create one FACH\_IT for each group of MBMS services that have the same QoS requirements. The MBMS services that belong to the same QoS group are associated with the same QoS ID and the same FACH\_IT is used for all of them.

It is also important to point out that the number of the Zone Areas (ZAs) the cell should be divided is highly affected by the environment used (pedestrian, vehicular, high vehicular etc), the network capacity gains and QoS desired to be achieved and the periodicity (period T) of reporting that will be used (note that the periodicity of reporting highly influences the Terminal's battery consumption and uplink noise rise). For example, if the operating environment of the cell is high vehicular (i.e., speeds of 120 Km/hour), dividing the cell in 100 or 200 ZAs may not be efficient, since frequent intra-cell handovers may occur, which can affect the network performance and the QoS experienced by the users.

Note however that the frequency of intra-cell handovers can be significantly reduced if very frequent context reporting is used. Moreover, the frequency of intra-cell handovers can be much further reduced if we set the periodicity of reporting such that **Period T < "QoS Safety time"** (the role of the "QoS Safety time" is described below). However, the higher the frequency of context reporting, the higher the terminal's battery consumption and the higher the uplink noise rise due to reporting. On the other hand, the greater the "QoS Safety time" the less the capacity efficiency that can be achieved. Then again, the more the ZAs the cell is

divided, the higher the capacity gains that can be achieved (see section 4.7.1.4). Thus, the **number of Zone Areas** that a cell will be divided, the periodicity of reporting (**Period T**) and the “**QoS Safety time**” should be carefully selected by the Network Operator in such a way that capacity, QoS, Terminal and system performance efficiency is achieved.

Before starting the formation of the transmission arrangements, in order to lessen any possibility of QoS degradation to occur, it is essential to make sure that the MBMS users located near the cell’s edge (i.e., those that reported information related to their best neighbouring cell and an inter-cell handover may be required) will stay within the coverage of their serving cell for at least some amount of time (this amount of time will be decided by the Network Operator). Guaranteeing the aforementioned is vital in order to lessen any possibility for QoS degradation or frequent inter-cell handovers after the new Transmission Arrangement takes place. Thus for each MBMS user that is located near the cell’s edge, the algorithm considers the instantaneous CPICH  $E_c/N_0$  signal quality and the CPICH  $E_c/N_0$  alteration rate experienced from the serving cell and if the MBMS user is predicted to leave the serving cell in less than the specified amount of time (decided by the Network Operator), the MBMS user’s record will be moved to the best neighbouring cell’s CCIT in which it will be considered during the formation of the Transmission Arrangements. However, the MBMS user will continue receiving the MBMS service using the channel assigned to it in the “old” serving cell until the Transmission Arrangement that will be adopted in the best neighbouring cell is decided (i.e., the MBMS user will handover to the best neighbouring cell after a new channel is assigned to it). It is worth mentioning that inter-cell handovers are not in the scope of this research.

After the records of the MBMS users, that are predicted to leave their serving cell in less than the specified amount of time, are moved to their best neighbouring cell’s CCIT, the possible Transmission Arrangements that can be used for the MBMS service provision within the cell are formed. Using Table 10 as an example, where the cell is divided into 10 Zone

Areas (ZAs), the maximum of eleven possible Transmission Arrangements (TAs) can be formed (TA0 – TA10):

- **Transmission Arrangement 0:** All the MBMS users within the cell will be supported using DCHs. This is similar to the P-t-P transmission mode used with the current 3GPP MBMS service provision approach [2]. If this Transmission Arrangement is adopted within the cell, we will refer to it as “*DCH supported*” cell.
- **Transmission Arrangement 1:** Support using FACH the MBMS users that belong to Zone Area 1 (ZA1) (i.e., those that receive a CPICH Ec/No signal quality  $\geq 35$  dB) and based on their mobility (assessed using the CPICH Ec/No Alteration Rate they experienced) are predicted to stay within it for at least the next  $K$  amount of time (we will refer to this  $K$  amount of time as the “**QoS Safety time**”). All the other MBMS users within the cell will be supported using DCHs. Thus in this case the “FACH supported area” will be ZA1. The  $K$  amount of time can either be fixed (in order to avoid complexity in the RNC) or can be dynamically estimated by the algorithm. In this case it will be equal to the time required by the RNC to reliably switch an MBMS user from the “FACH supported area” to the “DCH supported area” (i.e., perform an intra-cell handover), plus an amount of time the MBMS user must stay connected to FACH before an intra-cell handover is allowed to occur (used in order to avoid frequent intra-cell handovers), plus an amount of time considered essential by the Network Operator for eliminating any possibility for QoS degradation. Thus, the MBMS users that will be supported using FACH in case this Transmission Arrangement is selected are all those that lies within Zone Area 1 and whose

$$CPICH\ Ec/No\ signal\ quality\ received + (CPICH\ Ec/No\ Alteration\ Rate\ x\ K) \geq 35dB$$

We will refer to the  $CPICH\ Ec/No\ Alteration\ Rate\ x\ K$  as the “**Mobility Predictor**” parameter. Its role is to predict the mobility of the MBMS users during the formation of the Transmission Arrangements and lessen any possibility for QoS degradation, or frequent intra-cell handovers, by ‘guaranteeing’ that all the MBMS users that will be



supported using FACH will stay within the “FACH supported area” for at least  $K$  more amount of time. Thus, even if an MBMS user lies within Zone Area 1, in case he is predicted to leave Zone Area 1 in less than  $K$  amount of time, this MBMS user will be directly supported using DCH. If this kind of Transmission Arrangement is adopted within a cell, we will refer to it as “*DCH+FACH supported*” cell.

- **Transmission Arrangement 2:** Support using FACH the MBMS users that belong to Zone Area 2 (ZA2) (i.e., those that receive a CPICH Ec/No signal quality  $\geq 21.5$  dB) and based on their mobility are predicted to stay within it for at least  $K$  more amount of time. Thus, the users that will be supported using FACH in case this Transmission Arrangement is selected are all those that lies within Zone Area 2 and whose:

$$CPICH\ Ec/No\ signal\ quality\ received + (CPICH\ Ec/No\ Alteration\ Rate\ x\ K) \geq 21.5dB$$

All the other MBMS users within the cell will be supported using DCH. Thus, in this case the “FACH supported area” will be ZA2. If this kind of Transmission Arrangement is adopted within a cell, we will refer to it as “*DCH+FACH supported*” cell.

- **Transmission Arrangement 3 to 9:** Transmission Arrangements 3 to 9 can be defined similarly to Transmission Arrangements 1 and 2. If these kind of Transmission Arrangements are adopted within a cell, we will refer to it as “*DCH+FACH supported*” cell
- **Transmission Arrangement 10:** All the MBMS users within the cell will be supported using FACH. This is similar to the P-t-M transmission mode used with the current 3GPP MBMS service provision approach. If this Transmission Arrangement is adopted within a cell, we will refer to it as “*FACH supported*” cell. Note that with this Transmission Arrangement DCHs are not allowed to be used. The reason for doing that is to bound the maximum downlink transmission power that can be used within the cell to the one required for supporting the whole cell using FACH (i.e.,

2.0222 watts to cover ZA10 as indicated in Table 10). Thus, with this Transmission Arrangement special attention should be given to the MBMS users that are located near the cell's edge. However, as indicated above, the records of the MBMS users located near the cell's edge that are predicted to leave ZA10 in less than a specific amount of time, are already moved to their best neighbouring cell's CCITs (just before the formation of the possible Transmission Arrangements takes place).

Thus, upon completion of the Information Collection step, the algorithm, by considering the CCIT (which includes the instantaneous context of the MBMS users within the cell) and the FACH\_IT as input (these tables have the same Cell ID and QoS ID) forms the possible Transmission Arrangements that can be used for the MBMS service provision within the cell and estimates the total transmission power required for each. It is worth mentioning here that, in some cases, the algorithm will not have to form and estimate the capacity requirements of all the Transmission Arrangements described above, but only those that are considered essential (see section 4.7.2).

In order to further improve the performance, after these Transmission Arrangements are estimated, the algorithm can also check if there are MBMS users that are located within the overlap area of two cells. If yes, the algorithm can check if there is any possibility for any further capacity enhancement to be achieved by re-distributing those MBMS users between these two cells. This is beyond the scope of the thesis, and we plan to investigate in the future.

Then, the Final Decision step is initiated in order to decide the Transmission Arrangement that will be used and adopts it. It is worth mentioning here that all the Transmission Arrangements formed during this step, guarantee the QoS requested for all the MBMS users. Also the number of the Transmission Arrangements that can be formed is based on the number of the Zone Areas the cell is divided into.

#### 4.7.1.1.3 Final Decision step

Once the Transmission Arrangements Estimation step is finished, the algorithm will select among all possible Transmission Arrangements formed the one that fulfils the requested QoS with the least amount of transmission power consumption. Once selected, the size of the FACH and the DCH supported areas are defined, the required radio resources are allocated, the users are informed about the channel that is selected for them to receive and the appropriate channels are established and assigned to them. Then the MBMS content starts to transmit.

Also, once the Transmission Arrangement that will be adopted within the cell is decided, the value indicating the coverage limit of the Zone Area that will be supported using FACH (i.e., the CPICH Ec/No signal quality that depicts the FACH's supported area coverage limit) as well as the thresholds related to the specific Zone Area (i.e., initial Activation Hysteresis), that will be used by the UEs for intra-cell handover purposes (see section 4.7.4.2) will be broadcast within the cell through the MCCH. Since the MCCH already includes information in relation to the MBMS service supported in the current cell [9] (*MBMS Current Cell P-t-M Radio Bearer Information*) the aforementioned information can be included there.

For easy reference, the algorithm is summarized, using pseudocode, in Figure 44 below.

<u>INITIALIZATION PHASE</u>
<i>Note: In the following example we assume that a cell is divided into J number of Zone Areas (ZAs)</i>
<i>First create the CCIT, collect the context information required and create the MBMS users' records.</i>
Execute <b>Information Collection Step</b>
<i>Form the new possible Transmission Arrangements (<math>TA_0 - TA_J</math>) that can be used for the MBMS service provision within the cell, estimate the transmission power required for each and then select the most efficient one to adopt.</i>
For each MBMS user record in the CCIT, estimate the power required if a DCH is established;
<b>Total Power for <math>TA_J</math></b> = FACH Power to cover $ZA_J$ (i.e., to cover the whole cell's area)
<b>Minimum Power = Total Power for <math>TA_J</math>;</b>
<b>Selected Zone Area</b> = $ZA_J$ (The case where the whole cell's coverage will be supported using FACH);
For $i = J - 1$ to 1 do
{
<b>Total Power for <math>TA_i</math></b> = FACH Power to cover $ZA_i$ + Sum of DCHs Power for UEs outside $ZA_i$ + Sum of DCHs Power for UEs within $ZA_i$ who predicted to leave $ZA_i$ in less than $K$ sec;
}

```

If (Total Power for TAi < Minimum Power) then
{
  Minimum Power = Total Power for TAi;
  Selected Zone Area = ZAi;
}
}

Total Power for TA0 = Total Downlink Power needed if all DCHs established;
If (Total Power for TA0 < Minimum Power)
  Selected Zone Area = ZA0;

Now establish the appropriate FACH and DCH channels according to the Transmission Arrangement selected.
Note that the Transmission Arrangement that will be used is determined based on the Zone Area selected to be
supported using FACH.

For every MBMS user lying in Selected Zone Area and NOT predicted to leave it in K sec
  Type of Connection = FACH
Otherwise
  Type of Connection = DCH

For each MBMS user with Type of Connection == DCH establish one DCH;
Establish FACH to cover the Selected Zone Area and support all the other MBMS users within the cell;
Set in the CCIT, the "Zone Area supported using FACH" field = Selected Zone area;

Inform the users within the cell about the Zone Area that will be supported using FACH and the thresholds
that should be considered during an intra-cell handover..

Broadcast through the MCCH the:
  Zone Area supported using FACH and
  The related thresholds that will be used by the UEs for intra-cell handover purposes;

```

Figure 44 Dual Transmission mode cell – Initialization phase pseudocode

#### 4.7.1.2 MBMS Session Ongoing Phase

During the session, users might join or leave the MBMS service, enter or leave the cell or even move within the cell, thus changing the context of the cell and possibly making another Transmission Arrangement more efficient than the one currently used. Therefore, during the session, the algorithm must periodically be executed in order to accommodate these variations and dynamically adapt to the most efficient Transmission Arrangement.

##### 4.7.1.2.1 Information Collection step

During the MBMS session, the RNC in order to accommodate the changes occurring through time in the cell's context, periodically (period T) notifies the MBMS users (as described in section 4.7.2) within the cell to report their new context. Based on the new context received, the CCIT is updated accordingly in order to depict to the algorithm the new

distribution and movement of the MBMS users within the cell. Similarly to the initialization phase, at the end of the Information Collection step, the CCIT will not necessarily include one record for each MBMS user within the cell (see section 4.7.2). However, it will include enough context information that will facilitate the algorithm to form and select the Transmission Arrangement that will provide the required QoS to all the MBMS users with the least amount of transmission power (i.e., capacity) consumption.

It is worth mentioning that the Period T (i.e., frequency of reporting) is a parameter that highly influences the MBMS service provision efficiency. Due to its importance, it is further analysed in section 4.7.1.3.

Moreover, techniques for reducing the need for reporting will be beneficial both for the users (in terms of terminal battery consumption) and also for the network (in terms of uplink noise rise and congestion). Thus, in section 4.7.2 we propose a new context reporting request process in order to achieve efficiency during the Information Collection step.

#### **4.7.1.2.2 Transmission Arrangements Estimation step**

Once the Information Collection step is finished, the updated CCIT with its related FACH\_IT are passed as input to the algorithm and new possible Transmission Arrangements, similarly to section 4.7.1.1.2, are formed. Then, the new amount of transmission power required for each is estimated and the Final Decision step is initiated.

It is worth mentioning here that, similarly to the Initialization phase, the algorithm will not have to form and estimate the capacity requirements of all the Transmission Arrangements described above, but only those that are considered essential (see section 4.7.2).

#### **4.7.1.2.3 Final Decision step**

In this step, the algorithm, by considering the new possible Transmission Arrangements formed, checks if a more efficient transmission arrangement than the one currently used exists and adopts it. It is worth mentioning that if a new Transmission Arrangement will be used,

this is determined based on the new Zone Area of the cell that will be supported using FACH.

Thus, there are three cases:

- *The new Zone Area selected is the same as the old one:* In this case the Transmission Arrangement currently used is considered as the most efficient. Thus, the algorithm will take no actions in this case.
- *The new Zone Area selected is smaller than the Zone Area currently supported using FACH (i.e., the “FACH supported area” will shrink):* In this case, some MBMS users previously included in the “FACH supported area” will be moved out of it. Thus, in order to avoid any QoS degradation, the algorithm will first establish and assign a DCH for each MBMS user that was previously receiving the service using FACH and then reduce the FACH transmission power to the one required for covering the new Zone Area selected.
- *The new Zone Area selected is larger than the Zone Area currently supported using FACH (i.e., the “FACH supported area” will expand):* In this case, some MBMS users previously included in the “DCH supported area” will now be included in the “FACH supported area”. In this case, the algorithm will first increase the FACH transmission power to the one required for covering the new Zone Area selected, inform the new MBMS users included in the “FACH supported area” to acquire from MCCH the configurations of the FACH channel and then release their DCH connections.

It should be pointed out here that during the MBMS session when the total downlink power used within a cell (i.e., power used for FACH + power used for DCHs) exceeds the amount of transmission power required to be devoted to FACH for supporting the whole cell's area (i.e., 2.0222 watts to cover ZA10, as indicated in Table 10), the algorithm automatically increases FACH's transmission power to cover the whole cell and releases all DCHs. This is done in order to limit the maximum transmission power that can be used within the cell to the one required for supporting the whole cell's area using FACH.

For easy reference, the algorithm is summarized, using pseudocode in Figure 45 below.

**MBMS SESSION ONGOING PHASE**

**Periodically** (Period T) and until the End of the MBMS session do the following  
{

*Collect the context information required and update the MBMS users' records.*

Execute **Information Collection step**;

*Form the new possible Transmission Arrangements ( $TA_0 - TA_J$ ) that can be used for the MBMS service provision within the cell, estimate the transmission power required for each and then select the most efficient one to adopt.*

For each MBMS user record in the CCIT, estimate the power required if a DCH is established;

**Total Power for  $TA_J$**  = FACH Power to cover  $ZA_J$  (i.e., to cover the whole cell's area)  
**Minimum Power** = **Total Power for  $TA_J$** ;  
**Selected Zone Area** =  $ZA_J$  (The case where the whole cell's coverage will be supported using FACH);

For  **$i = J - 1$  to 1** do  
{  
**Total Power for  $TA_i$**  = FACH Power to cover  $ZA_i$  + Sum of DCHs Power for UEs outside  $ZA_i$  +  
Sum of DCHs Power for UEs within  $ZA_i$  who predicted to leave  $ZA_i$  in less than  $K$  sec;

If (**Total Power for  $TA_i$  < Minimum Power**) then  
{  
**Minimum Power** = **Total Power for  $TA_i$** ;  
**Selected Zone Area** =  $ZA_i$ ;  
}  
}

**Total Power for  $TA_0$**  = Total Downlink Power needed if all DCHs established;  
If (**Total Power for  $TA_0$  < Minimum Power**)  
**Selected Zone Area** =  $ZA_0$ ;

*The TA that will be used in the cell is decided (indicated by the value selected for the new Selected Zone Area). Now perform the appropriate actions in order for the new TA to be adopted. There are three cases here:*

If (new **Selected Zone Area** == current **Zone Area supported using FACH**) then  
Do Nothing. The new TA will be the same as the one currently used. If an MBMS user joins/leaves the session, or performs an intra- cell handover, will be handled by other algorithms that run in parallel.

If (new **Selected Zone Area** > current **Zone Area supported using FACH**) then {

1. Increase FACH power to cover the new Selected Zone Area;
2. Set in the CCIT the **Zone Area supported using FACH = new Selected Zone Area**;
3. Broadcast through the MCCH the **Zone Area supported using FACH and the related thresholds that will be used by the UEs for intra-cell handover purposes**;
4. For each MBMS user currently included in the new Selected Zone Area and Not predicted to leave it within the next  $K$  sec:
  - a. Inform the MBMS user's UE to be reconfigured and start receiving the MBMS service using the FACH;
  - b. Set the MBMS user's **Type of Connection = FACH**;
  - c. Release the DCH previously established for the MBMS user; }

If (new **Selected Zone Area** < current **Zone Area supported using FACH**) then {

1. For each MBMS user just removed from the new **Selected Zone Area** and also for each MBMS user that lies within the new **Selected Zone Area** but predicted to leave it in less than  $K$  sec.
  - a. Establish a DCH;
  - b. Inform the MBMS user's UE to be reconfigured and start receiving the MBMS service using the new DCH;
  - c. Set the MBMS user's **Type of Connection = DCH**.

```

2. Decrease FACH power to cover the new Selected Zone Area
3. Set in the CCIT the Zone Area supported using FACH = new Selected Zone Area;
4. Broadcast through the MCCH the Zone Area supported using FACH and the related thresholds that will be used by the UE for intra-cell handover purposes;
    }
}

```

*During the MBMS session, the maximum power that should be used for the distribution of the MBMS service within the cell must not exceed the amount of power required to support the whole cell's coverage using FACH. When exceeded, the algorithm automatically increases FACH's transmission power to cover the whole cell and releases all the DCHs.*

```

Continuously during the MBMS session do the following
1. If power required for FACH + power required for DCHs becomes greater than the power required for covering the whole cell's area using FACH then:
    a. Increase FACH's transmission power to cover the whole cell's area;
    b. Notify all the MBMS users within the cell to start receiving the service using FACH;
    c. Set their Type of Connection = FACH;
    d. Release all the DCHs previously used by the MBMS users;
2. Set in the CCIT the Zone Area supported using FACH = ZAj;
3. Broadcast through the MCCH the Zone Area supported using FACH and the related thresholds that will be used by the UE for intra-cell handover purposes;

```

Figure 45 Dual Transmission mode cell – MBMS Session ongoing phase pseudocode

#### 4.7.1.3 Periodicity of Reporting (Period T)

The period T (i.e., the frequency of reporting) is a parameter that highly influences the performance of the algorithm and should be chosen as a tradeoff between the capacity, the uplink noise rise and the Terminal's battery consumption efficiency. In Figure 46 we show some results illustrating how the period T can affect the efficiency of the aforementioned factors. A three (3) minute duration steaming video of 64 Kbits/sec was used. Sixty (60) users were set-up to move randomly within the cell (the radius of the cell is 1 Km) with a speed of ~30 Km/hour. Ten instances of the same scenario have been simulated, each using a different period T, from 1 to 10 seconds.



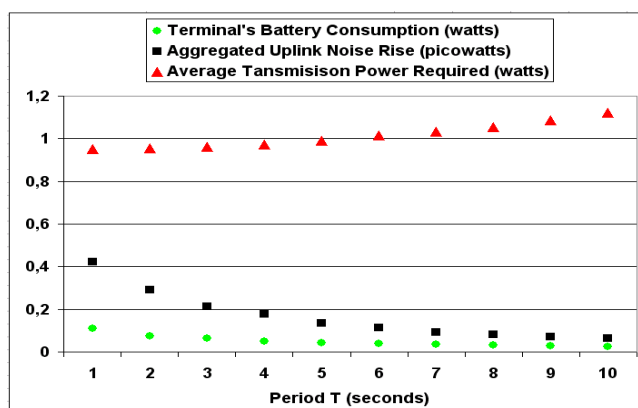

Figure 46 Affect of period T on efficiency

As shown in Figure 46, the higher the value set for the period T, the higher the average downlink power required but the less the terminal's battery consumption and uplink noise rise. Since not only the downlink capacity but also the uplink interference and the terminal's battery life are also considered as critical factors in the MBMS service provision efficiency, the period T should be carefully selected so as not to sacrifice the efficiency of the one factor over the other. Taking into consideration the results shown above, for the presented scenario, a period T of about 4 seconds is a good compromise choice. However, if the Network Operator desires maximum capacity gains, a shorter period T, of say 1 second, can be used. Also, if required, the period T can be dynamically adjusted based on the available capacity in the cell. For example, if the cell becomes very loaded and radio resources are getting limited, then the period T can be decreased for more frequent reporting and thus sacrifice battery consumption and uplink noise efficiency for increased capacity. Otherwise, if the cell's radio resources is not an issue, the period T can be increased for less frequent reporting and thus sacrifice capacity efficiency for increased battery life and reduced uplink noise.

It is also important to note here that, the higher the value set for the *Period T*, the more the intra-cell handovers that are expected to occur. Thus, in order to reduce the number of intra-cell handovers, the *Period T* should not exceed the amount of time set for parameter "*QoS Safety time*" *K* (see section 4.7.1.1.2 for "*mobility predictor*" parameter), in order to facilitate the algorithm to adjust the Transmission Arrangement used before any intra-cell handover

takes place. Having the amount of *Period T* less than the amount of “*QoS Safety time*” *K*, can increase the performance considerably.

#### **4.7.1.4 Number of Zone Areas Vs Capacity efficiency and Complexity**

The number of Zone Areas that the cell is divided into is a parameter that highly influences the capacity efficiency that can be achieved in the cell during the MBMS service provision. Note that the number of possible Transmission Arrangements that can be used for the MBMS service provision within the cell is associated with the number of the Zone Areas the cell is divided into (i.e., if number of Zone Areas =  $J$  then the number of all possible Transmission Arrangements that can be formed =  $J + 1$ ). Therefore, the more the Zone Areas the cell is divided into the more the processing effort required by the RNC to form the Transmission Arrangements that can be used and estimate the capacity requirements for each, but the higher the expected capacity gains.

In the figures below, we provide some results illustrating how the number of Zone Areas the cell is divided into can influence the capacity efficiency that can be achieved, in cells with different number of MBMS users moving within. Results have been collected, assuming a low loaded (20 MBMS users), a medium loaded (40 MBMS users) and a high loaded cell (70 MBMS users) scenario. Six instances of each scenario have been simulated in which we divided the cell into 5, 10, 20, 50, 100 and 200 Zone Areas. In these scenarios the MBMS users are receiving a six (6) minute duration steaming video of 64 Kbits/sec and set-up to move randomly within the cell (the radius of the cell is 1 Km) with a speed of 6 - 8 Km/hour. The simulation parameters used are provided in Table 11.

Table 11 Simulation Parameters – Number of Zone Areas Vs Capacity efficiency and complexity

Simulation Parameter	Value
Traffic used	64 Kbits/sec MBMS Streaming video clip, Duration: 6 minutes
Propagation environment	Urban Pedestrian Outdoor
UEs' speed	5 – 7 Km/hour (1.38 – 1.94 meters/sec)
Cell radius	1000 meters
Node-B Antenna type	Omnidirectional
Shadow fading <sup>7</sup>	Standard deviation log-normal of 10 dB
Transmission Time Interval (TTI)	20 ms
Channel coding	Convolutional 1/3 coding rate
Downlink Other-cell Interference factor	1.78
Thermal Noise power spectral density	-174 dBm
Orthogonality factor	0.5

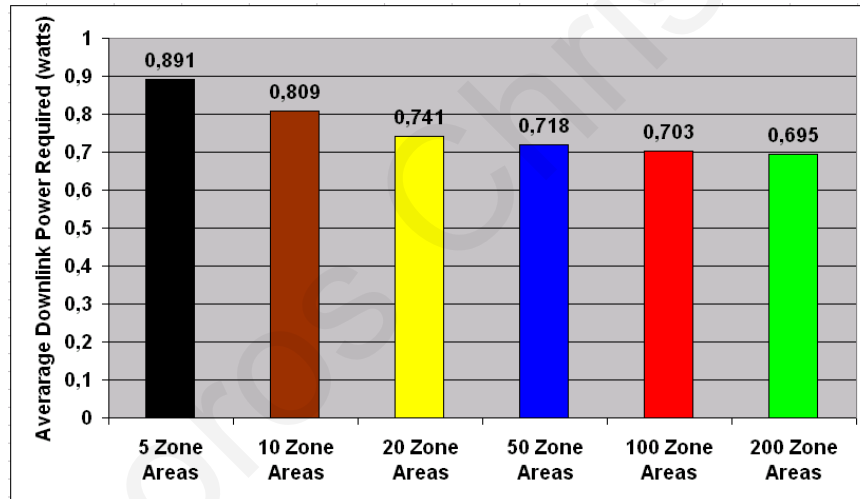

Figure 47 Affect of number of Zone Areas on capacity efficiency (low loaded cell)

Table 12 Affect of number of Zone Areas on capacity efficiency (low loaded cell)

Number of Zone Areas	5	10	20	50	100	200
Average Downlink Power Required (watts)	0.891	0.809	0.741	0.718	0.703	0.695
Capacity Efficiency Gain (%)	28.2% more	16.4% more	6.6% more	3.3% more	1.15% more	Reference case

<sup>7</sup> The amplitude change caused by shadowing is often modelled using a log-normal distribution with a standard deviation according to the log-distance path loss model. The log-distance path loss model is a radio propagation model that predicts the path loss a signal encounters inside a building or densely populated areas over distance.

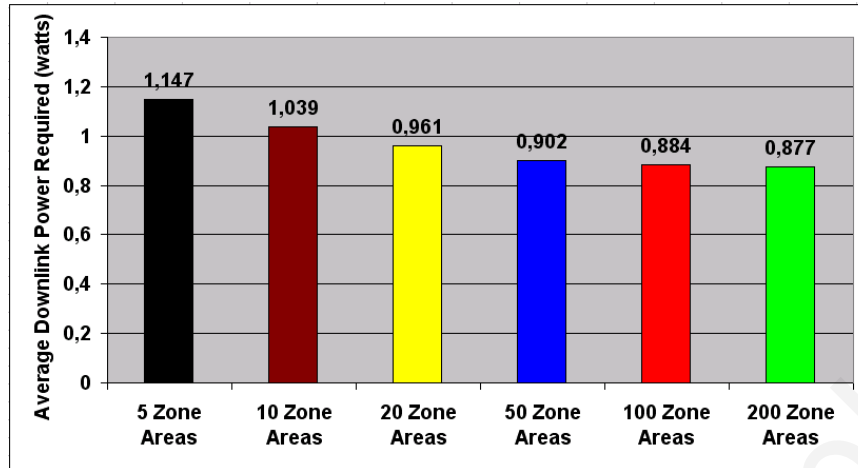

Figure 48 Affect of number of Zone Areas on capacity efficiency (medium loaded cell)

Table 13 Affect of number of Zone Areas on capacity efficiency (medium loaded cell)

Number of Zone Areas	50	5	10	20	100	200
Average Downlink Power Required (watts)	0.902	1.147	1.039	0.961	0.884	0.877
Capacity Efficiency Gain (%)	2.85% more	30.8% more	18.5% more	9.6% more	0.8% more	Reference case

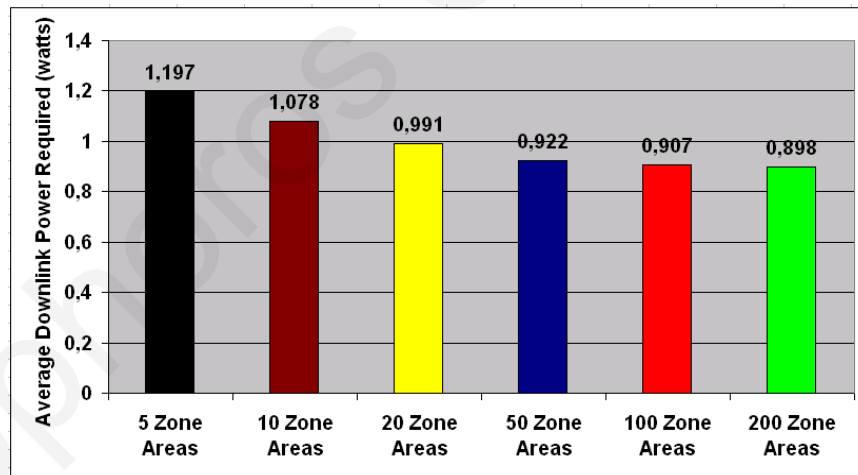

Figure 49 Affect of number of Zone Areas on capacity efficiency (high loaded cell)

Table 14 Affect of number of Zone Areas on capacity efficiency (high loaded cell)

Number of Zone Areas	5	10	20	50	100	200
Average Downlink Power Required (watts)	1.197	1.078	0.991	0.922	0.907	0.898
Capacity Efficiency Gain (%)	33.4% more	20% more	10.3% more	2.7% more	1% more	Reference case

As illustrated in Figure 47 - Figure 49 and Table 12 - Table 14, the higher the number of Zone Areas the cell is divided into, the more capacity gains that can be achieved. Above we observed that, for all scenarios simulated and having as a reference the case where the cell is divided into 200 ZAs, an average of ~1% more power required when the cell is divided into 100 ZAs, an average of ~3% more power is required when the cell is divided into 50 Zone Areas, an average of ~9% more power is required when the cell is divided into 20 Zone Areas, an average of ~ 18% more power is required when the cell is divided into 10 Zone Areas, and an average of ~ 30% more power is required when the cell is divided into 5 Zone Areas.

Thus, we can imply here that the number of Zone Areas that the cell should be divided is not influenced by the load present in the cell. The more the Zone Areas the cell is divided into the higher the capacity gains that can be achieved in the system, but as the number increases the returns are becoming limited. Also note that the higher the Zone Areas the cell is divided into, the more the Transmission Arrangements that have to be formed and thus the more the processing effort required by the RNC. Note that the processing effort required by the RNC to form all possible Transmission Arrangements that can be used and also estimate the capacity requirements of each, for a cell divided into 200 Zone Areas, is estimated (assuming the worst case scenario) in section 4.7.5 and requires only the 0.5% of the total RNC's processing power, which can be considered trivial. However, the part that needs some work by the Network Operator is to define the coverage limit of each Zone Area and also the power that needs to be devoted for FACH for covering the Zone Area. Thus the more the Zone Areas the cell is divided into the more the work that has to be performed, during the Radio Network Planning, by the Network Operator. Thus in order to lessen the work that has to be done during the Radio Network Planning, by taking into consideration the results shown above, dividing the cell into 50 Zone Areas is a good compromise choice (only an average of ~3% more power, compared to the best case, is required), since as it can be seen, above 50 Zone Areas the gains are of limited returns.

#### 4.7.2 Proposed Context Reporting Request process

As discussed above, techniques for reducing the need for context reporting will be beneficial both for the UEs (in terms of terminal battery consumption) and also for the network (in terms of uplink noise rise, uplink congestion, processing effort and time required for decision making efficiency). Thus, the main challenges of our proposed context reporting request process approach are to:

- Reduce from the UEs the need for frequent and redundant context reporting (and thus achieve terminal battery consumption efficiency)
- Avoid having all the UEs to report at the same time (and thus reduce the possibility for uplink congestion and also the uplink noise rise)
- Avoid receiving redundant context reporting from the UEs (and thus achieve reduced processing effort and faster radio resource allocation decisions in the RNC, as well as reduced terminal battery consumption in the UEs).

In order to address the challenges presented above, we describe next a new context reporting request process that we adopt during the Information Collection step.

Firstly, in order to avoid frequent or redundant context reporting from the UEs (mainly from those UEs that remain static), we set a “reporting threshold” value and have the UEs report only when their instantaneous CPICH  $E_c/N_0$  received differs from the one previously reported by this “reporting threshold”.

Moreover, in order to avoid congestion in the uplink, instead of notifying all the UEs to report at the same time (as done by all the other related approaches described in section 4.2), we perform the context reporting request process in a more scalable fashion, by requesting reports in successive steps (i.e., notify the UEs zone by zone; see Figure 50), and more importantly starting requesting reports from those UEs that are located close to the cell’s edge (since these UEs, that are closer to the cell’s edge, are considered as more “critical” to report than those close to the Node-B). For example, considering Table 10 in which the cell is divided into 10 Zone Areas, the RNC will first notify for reporting those UEs that are outside

or are predicted to leave Zone Area 9 (ZA9) in less than a “QoS Safety time” amount of time, then those that are outside or are predicted to leave Zone Area 8 (ZA8) in less than a “QoS Safety time” amount of time, and so on. For example, when the RNC wants to notify the UEs that are outside or are predicted to leave ZA9 in less than a “QoS Safety time” amount of time, it will broadcast, through the MCCH, the **CPICH Ec/No signal quality indicating the coverage limit of ZA9** (that is -5.4 dB) and the **“QoS Safety time”** that should be considered by the UEs for providing a report. Then, when this notification is received by the UEs, the UEs that have to report are all those that receive the *CPICH Ec/No signal quality*  $< -5.4$  dB (i.e., those that are outside ZA9), plus those that the received *CPICH Ec/No signal quality* + (*CPICH Ec/No Alteration Rate*  $\times$  “QoS Safety time”)  $< -5.4$  dB (i.e., those that are predicted to leave ZA9 in less than the **“QoS Safety time”** amount of time).

It is important to note here that UEs that already reported will not have to report again. For example, based on Table 10, where the cell is divided into 10 Zone Areas, the algorithm will first request the UEs that are outside ZA9 to report their context (in this case ZA9 is indicated as the  $\mathbf{ZA}_{\text{Cur}}$  in Figure 50). So, the UEs that have to report are all those that are outside or are predicted to leave ZA9 in less than the **“QoS Safety time”** amount of time, but inside ZA10 (in this case ZA10 is indicated as the  $\mathbf{ZA}_{\text{Prev}}$  in Figure 50). Then, when the algorithm notifies the UEs that are outside of ZA8 to report, the UEs that already reported do not have to report again. Thus in the second step of the algorithm, the UEs that have to report are all those that are outside or are predicted to leave ZA8 in less than the **“QoS Safety time”** amount of time, but inside ZA9 (i.e., in the second step of the algorithm  $\mathbf{ZA}_{\text{Cur}} = \mathbf{ZA8}$  and  $\mathbf{ZA}_{\text{Prev}} = \mathbf{ZA9}$ ). Then, in the third step of the algorithm, when the UEs outside of ZA7 are notified for reporting, the UEs that have to report are all those that are outside or are predicted to leave ZA7 in less than the **“QoS Safety time”** amount of time, but inside ZA8 (i.e., in this case  $\mathbf{ZA}_{\text{Cur}} = \mathbf{ZA7}$  and  $\mathbf{ZA}_{\text{Prev}} = \mathbf{ZA8}$ ), and so on.

It is also worth mentioning that performing the reporting request process zone by zone is not a strict requirement. In order to speed up the process, we can perform it every two (i.e.,

ZA8, ZA6, ZA4, etc.) or every three (i.e., ZA7, ZA4, ZA1, etc.) zones, or even in more dynamic steps (i.e., ZA7, ZA6, ZA3, ZA1, etc.) depending on the current cell's load (i.e., the number of the MBMS users present in the cell, which is known to the RNC) and the previous MBMS users' context included in the CCIT (i.e., based on previous distribution and movement of the MBMS users within the cell - this will be considered during the MBMS session ongoing phase). For example, if based on the latest context information included in the CCIT designating the previous distribution and movement of the UEs within the cell, the algorithm indicates that all the UEs must be located below ZA7, the algorithm instead of start requesting for context reports from the cell's edge (i.e., instead of initializing  $ZA_{Cur} = ZA9$ ), it can start requesting for context reports directly from those UEs that are outside or are predicted to ZA6 in less than the "QoS Safety time" (i.e., initialize  $ZA_{Cur} = ZA6$ ). This can significantly speed up the whole process since unnecessary context reporting steps (i.e., requesting context reports in areas that UEs are not located) will be avoided.

In addition to above, in order to avoid having a large number of UEs attempting to report at the same time (and thus reduce the possibility for uplink congestion in cases where a great number of users are present in the cell and all attempt to report at the same time), we use the idea of the Probability Factor (PF) (as described in [2]) that the UE will consider before attempting to report ( $0 < PF \leq 1$ ). This PF is broadcast through the MCCH (see [2]). Thus, when the UEs outside of a Zone Area (i.e., outside of the  $ZA_{Cur}$ ) are notified for reporting, they produce a random number between 0 and 1, and if lower than or equal to the PF, a report will be provided to the RNC. Note that the initial value of the PF will be decided dynamically by the RNC based on the current cell's load (i.e., the number of the MBMS users present in the cell, which is known to the RNC) and the previous context reported by the MBMS users which is included in the CCIT (i.e., based on their previous distribution and movement within the cell - this will be considered during the MBMS session ongoing phase). For example, if the number of the UEs outside of the  $ZA_{Cur}$  is low, the PF can be initialized to 1 (this will have all the UEs outside or predicted to leave  $ZA_{Cur}$ , to attempt to report at the same time). On the



other hand, if the number of the UEs outside of the  $ZA_{Cur}$  is high, the PF can be initialized to a lower value, e.g.,  $PF = 0.33$  (in order to have one third of the UEs to attempt to report at the same time). Then, the PF will be increased in steps (i.e.,  $PF_1 = 0.33$ ,  $PF_2 = 0.66$ ,  $PF_3 = 1.00$ ), until all the UEs outside or are predicted to leave  $ZA_{Cur}$  report their context (i.e., the PF becomes equal to 1). In this case, the algorithm will proceed and start notifying the UEs further inside the cell to report (e.g., notify those that are outside or are predicted to leave  $ZA_{Cur-1}$  in less than the “QoS Safety time” amount of time, to report).

It is very important to mention here that the context reporting request process can be interrupted, if the algorithm indicates that further reporting is redundant, and proceed immediately to the Transmission Arrangement Estimation step. As illustrated in Figure 50, the algorithm can interrupt the context reporting request process if one of the following events occurs:

1. If all the UEs in the cell have reported ( $ZA_{Cur} < 0$ ; note that when  $ZA_{Cur}$  becomes equal to -1 this means that all the UEs within the cell have reported)
2. If, based on the context reports received until now (i.e., the context reports received from those UEs that are outside or are predicted to leave  $ZA_{Cur}$  in less than “QoS Safety time” amount of time), the estimated downlink transmission power required to be allocated for supporting the UEs located within the coverage area of a  $ZA_{Prev}$  using DCHs (i.e., the  $P_{DCHs\_upto\_ZA_{Prev\_index}, J \geq ZA_{Prev\_index} \geq 1}$ ; see Figure 50) becomes greater than the amount of downlink transmission power required to be allocated for supporting the coverage area of the  $ZA_{Prev}$  using FACH (i.e., the  $P_{FACH\_ZA_{Prev\_index}, J \geq ZA_{Prev\_index} \geq 1}$ ; see Figure 50). For example, the context reporting request process will be interrupted when at least one of the following conditions is met:

- $P_{DCHs\_upto\_ZA_J} > P_{FACH\_ZA_J}$ , or
- $P_{DCHs\_upto\_ZA_{J-1}} > P_{FACH\_ZA_{J-1}}$ , or
- $P_{DCHs\_upto\_ZA_{J-2}} > P_{FACH\_ZA_{J-2}}$ , or,
- ....., or
- $P_{DCHs\_upto\_ZA_1} > P_{FACH\_ZA_1}$

Where:

$$Z_{A_{Cur}} \in \{J-1, J-2, \dots, 0\}, Z_{A_{Prev}} \in \{J, J-1, \dots, 1\}, Z_{A_{Prev}} > Z_{A_{Cur}}$$

$J$  is the number of Zone Areas the cell is divided into

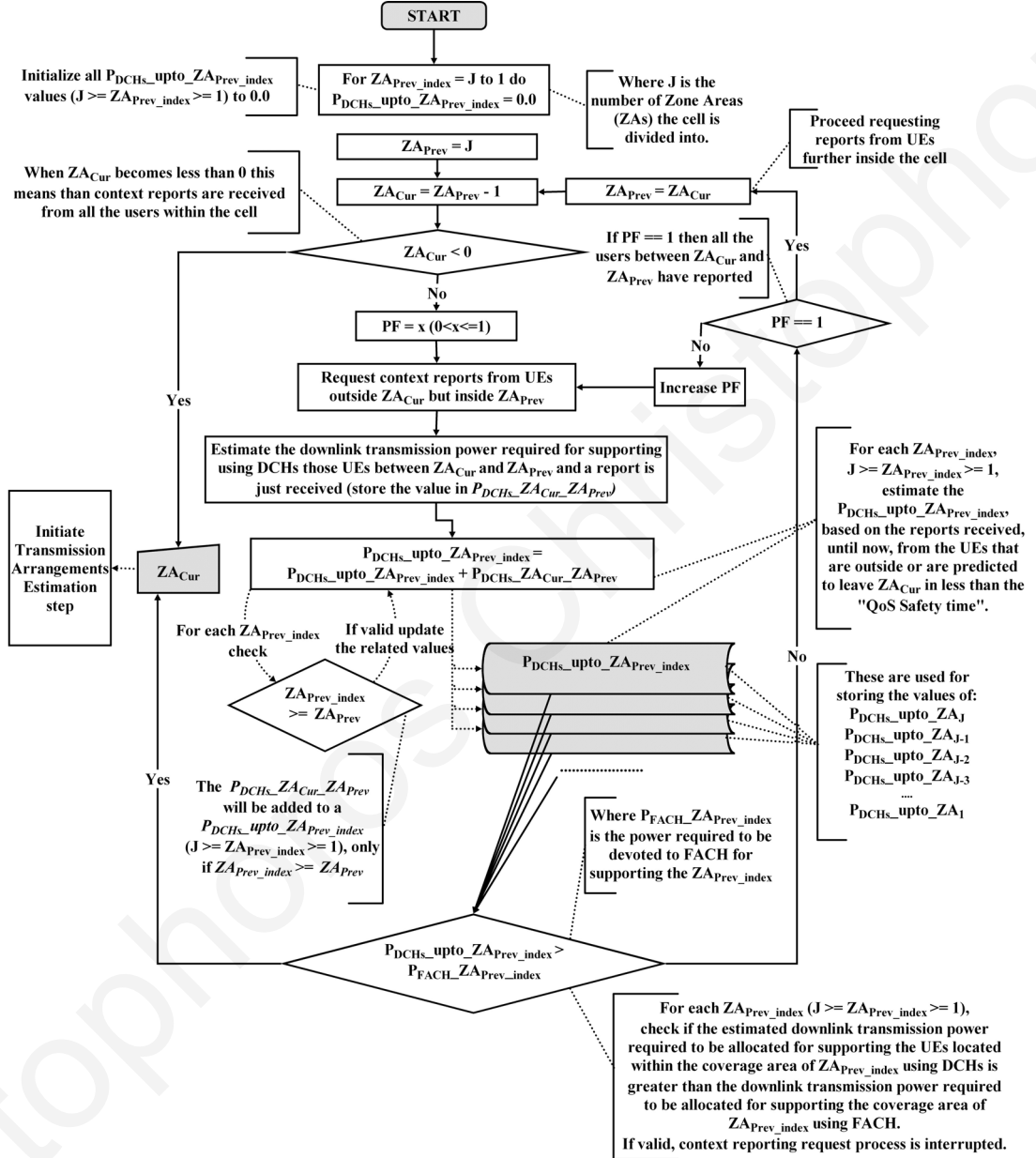

Figure 50 Proposed Context Reporting Request Process - Flowchart

If one of the above events occurs, the algorithm will interrupt the context reporting request process and initiate the Transmission Arrangement Estimation step by providing it as input the  $ZA_{Cur}$ . This will indicate to it where the context reporting request process was

interrupted and form only those Transmission Arrangements that support using FACH the previous Zone Area that was checked ( $ZA_{prev}$ ) and above. For example, assuming that the context reporting request process is stopped with those UEs outside Zone Area 6 (i.e.,  $ZA_{Cur} = ZA6$  and  $ZA_{prev} = ZA7$ ), the algorithm will form only those Transmission Arrangements for which FACH supports Zone Area 7 ( $ZA7$ ) and further. Thus, based on section 4.7.1.1.2, the algorithm will form only Transmission Arrangements 7 – 10, estimate the transmission power required for each and select among them the most efficient one to adopt.

Next we further clarify the reasons why the context reporting request process is better to be interrupted when one of the two events described above occurs. Interruption when the first event occurs is obvious; no more UEs are left to report. However, in order to clarify the reason interruption occurs for the second event, let us illustrate using the following example (using the flowchart illustrated in Figure 50 and the values included in Table 10, as a reference).

During the first step of the process, the RNC notifies the UEs located outside Zone Area 9 ( $ZA9$ ) to report their context (in this case  $ZA_{Cur} = ZA9$  and  $ZA_{prev} = ZA10$ ). Let us assume that during this step two UEs reported back and the estimated downlink transmission power (i.e., the  $P_{DCHs\_ZA9\_ZA10}$ ) required for supporting these UEs using DCHs is 0.48 watts. Thus the  $P_{DCHs\_ZA9\_ZA10} = 0.48$  watts. Based on the flowchart illustrated in Figure 50, this makes the:

- $P_{DCHs\_upto\_ZA10} = P_{DCHs\_ZA9\_ZA10} = 0.48$  watts.

The algorithm checks the following and if it is valid the context reporting request process is interrupted:

- $P_{DCHs\_upto\_ZA10} \stackrel{?}{>} P_{FACH\_ZA10} \rightarrow 0.48 \stackrel{?}{>} 2.0222$  watts (Not valid)

Since the above condition is not met, the context reporting request process continues.

During the second step of the process, the RNC notifies the UEs that are outside Zone Area 8 ( $ZA8$ ) to report their context (in this case  $ZA_{Cur} = ZA8$  and  $ZA_{prev} = ZA9$ ). Let us

assume now that during this step, four more UEs reported back and the estimated downlink transmission power (i.e., the  $P_{\text{DCHs\_ZA}_8\_ZA_9}$ ) required for supporting these four UEs using DCH is 0.68 watts. Thus, the  $P_{\text{DCHs\_ZA}_8\_ZA_9} = 0.68$  watts. This makes now the:

- $P_{\text{DCHs\_upto\_ZA}_{10}} = P_{\text{DCHs\_ZA}_8\_ZA_9} + P_{\text{DCHs\_ZA}_9\_ZA_{10}} = 1.16$  watts, and the
- $P_{\text{DCHs\_upto\_ZA}_9} = P_{\text{DCHs\_ZA}_8\_ZA_9} = 0.68$  watts.

The algorithm checks the following and if at least one is valid the context reporting request process is interrupted:

- $P_{\text{DCHs\_upto\_ZA}_{10}} > P_{\text{FACH\_ZA}_{10}} \rightarrow 1.16 > 2.0222$  watts (Not valid)
- $P_{\text{DCHs\_upto\_ZA}_9} > P_{\text{FACH\_ZA}_9} \rightarrow 0.68 > 1.3267$  watts (Not valid)

Since none of the conditions are met, the context reporting request process continues.

During the third step of the process, the RNC notifies the UEs that are outside Zone Area 7 (ZA7) to report their context (in this case  $ZA_{\text{Cur}} = ZA7$  and  $ZA_{\text{Prev}} = ZA8$ ). Let us assume now that during this step, ten more UEs reported back and the estimated downlink transmission power (i.e., the  $P_{\text{DCHs\_ZA}_7\_ZA_8}$ ) required for supporting these ten UEs using DCH is 1.15 watts. Thus, the  $P_{\text{DCHs\_ZA}_7\_ZA_8} = 1.15$  watts. This makes now the:

- $P_{\text{DCHs\_upto\_ZA}_{10}} = P_{\text{DCHs\_ZA}_7\_ZA_8} + P_{\text{DCHs\_ZA}_8\_ZA_9} + P_{\text{DCHs\_ZA}_9\_ZA_{10}} = 2.31$  watts,
- $P_{\text{DCHs\_upto\_ZA}_9} = P_{\text{DCHs\_ZA}_7\_ZA_8} + P_{\text{DCHs\_ZA}_8\_ZA_9} = 1.83$  watts,
- $P_{\text{DCHs\_upto\_ZA}_8} = P_{\text{DCHs\_ZA}_7\_ZA_8} = 1.15$  watts.

The algorithm checks the following and if at least one is valid the context reporting request process stops:

- $P_{\text{DCHs\_upto\_ZA}_{10}} > P_{\text{FACH\_ZA}_{10}} \rightarrow 2.31 > 2.0222$  watts (Valid)
- $P_{\text{DCHs\_upto\_ZA}_9} > P_{\text{FACH\_ZA}_9} \rightarrow 1.83 > 1.3267$  watts (Valid)
- $P_{\text{DCHs\_upto\_ZA}_8} > P_{\text{FACH\_ZA}_8} \rightarrow 1.15 > 0.8283$  watts (Valid)

In this case the algorithm will interrupt the context reporting request process since at least one of the above conditions is met.

Based on the above, next we estimate the total downlink transmission power required (watts) for each possible Transmission Arrangement described in section 4.7.1.1.2, using also Table 10 as a reference:

- TA10 = **2.0222 watts** ( $P_{\text{FACH\_ZA}_{10}}$ ; i.e. FACH covers whole cell)
- TA9 =  $1.3267 (P_{\text{FACH\_ZA}_9}) + 0.48 (P_{\text{DCHs\_ZA}_9\_ZA_{10}})$  = **1.8067 watts**
- TA8 =  $0.8283 (P_{\text{FACH\_ZA}_8}) + 0.68 (P_{\text{DCHs\_ZA}_8\_ZA_9})$   
 $+ 0.48 (P_{\text{DCHs\_ZA}_9\_ZA_{10}})$  = **1.9883 watts**
- TA7 =  $0.4855 (P_{\text{FACH\_ZA}_7}) + 1.15 (P_{\text{DCHs\_ZA}_7\_ZA_8})$   
 $+ 0.68 (P_{\text{DCHs\_ZA}_8\_ZA_9})$   
 $+ 0.48 (P_{\text{DCHs\_ZA}_9\_ZA_{10}})$  = **2.7955 watts**
- TA6 =  $0.2620 (P_{\text{FACH\_ZA}_6}) + D (P_{\text{DCHs\_ZA}_6\_ZA_7})$   
 $+ 1.15 (P_{\text{DCHs\_ZA}_7\_ZA_8})$   
 $+ 0.68 (P_{\text{DCHs\_ZA}_8\_ZA_9})$   
 $+ 0.48 (P_{\text{DCHs\_ZA}_9\_ZA_{10}})$  = **2.5720 + D watts**
- .....
- TA0 (All DCHs) =  $E (P_{\text{DCHs\_ZA}_0\_ZA_6})$   
 $+ D (P_{\text{DCHs\_ZA}_6\_ZA_7})$   
 $+ 1.15 (P_{\text{DCHs\_ZA}_7\_ZA_8})$   
 $+ 0.68 (P_{\text{DCHs\_ZA}_8\_ZA_9})$   
 $+ 0.48 (P_{\text{DCHs\_ZA}_9\_ZA_{10}})$  = **2.31 + D + E watts**

As observed above, once at least one of the context reporting interruption conditions is met (at the third step of the iteration where the  $\text{ZA}_{\text{Cur}} = \text{ZA}_7$ ; see TA7), the total downlink power required for this and all subsequent Transmission Arrangements (in the aforementioned

example TA0 – TA7) will require much more power than TA10, TA9 or TA8 (even if we assume D and E to be zero). Hence, context reporting request process can be interrupted here, since the most efficient transmission arrangement will be one of the TA10, TA9 or TA8 (in the aforementioned example is TA9) and thus further reporting would be redundant.

Also, in order to further reduce the need for context reporting, mainly in hot spot areas, we can define the smallest Zone Area of the cell that should be served using FACH (i.e., this smallest Zone Area will cover the hot spot area) and have only those UEs that are outside of this Zone Area to report.

### **4.7.3 Joining or Leaving the MBMS Service**

During the MBMS session, an MBMS user may decide to join or leave the MBMS service. Below, how the joining and leaving requests are handled by our algorithm are described.

#### **4.7.3.1 Joining an MBMS Service**

When an MBMS user wants to join an MBMS service, the UE in addition to the information already incorporated in the join request sent to the RNC (as specified in [1]), will also include within this request the following information:

- Instantaneous CPICH  $E_c/N_0$  signal quality received
- Instantaneous CPICH  $E_c/N_0$  alteration rate experienced

Requesting to Join an MBMS service is not so critical to be executed immediately since the QoS of the MBMS user cannot be affected. However, executing this join request immediately upon its reception might result in capacity inefficiencies if the algorithm assigns to this MBMS user a channel without considering the instantaneous context of the cell. It will be wiser sometimes to suspend this request and continue its execution on the next iteration of the algorithm. Therefore, once a join request is received by the RNC, the algorithm will create a record for the related MBMS user in the related CCIT, and store the instantaneous context information included. Then, the algorithm will check if based on its instantaneous context

received, the UE lies within the “FACH supported area” and also if it is predicted to stay within it for the next “*QoS Safety time*”  $K$  seconds (see section 4.7.1.2.1). If yes, the UE is assigned immediately to the FACH. Otherwise, the request is suspended and continues execution (i.e., a channel is assigned to the UE) at the next iteration (Period  $T$ ) of the algorithm.

#### **4.7.3.2 Leaving an MBMS Service**

When an MBMS user wants to leave the MBMS service, a leave request is sent to the RNC (as specified in [1]). Once a leave request is received by the RNC, the algorithm will immediately perform the following steps:

- If the MBMS user was receiving the MBMS service using FACH then the RNC will cancel any process associated with this MBMS user.
- If the MBMS user was receiving the MBMS service using DCH then the RNC will first release the DCH and cancel any process associated with this MBMS user.
- The record created for the MBMS user in the cell’s CCIT will be deleted.

#### **4.7.4 Mobility Considerations: Intra- and Inter- cell handovers**

As indicated in section 4.5, the radio resource allocation algorithm we proposed above, should not run continuously as this will cause increased terminal’s battery consumption and increased uplink noise rise, due to the measurement reporting required to be provided by the UEs. Hence, during the session there will be small periods of time during which this algorithm will be idle and thus any mobility of the MBMS users, more specifically intra- and inter- cell handovers, will not be accommodated, possibly resulting either in QoS or capacity inefficiencies. Thus, the mobility issues rising with this new concept must be considered with care in order for this new scheme to work efficiently. Below these issues are further analysed.

#### 4.7.4.1 Inter-cell Handovers

Based on the “Dual transmission mode cell” concept, there are three ways in which the MBMS service can be provided within a cell (see Figure 51):

- Fully supported using FACH (“FACH supported” cell)
- Fully supported using DCHs (“DCH supported” cell)
- Jointly supported using FACH and DCHs (“DCH+FACH supported” cell)

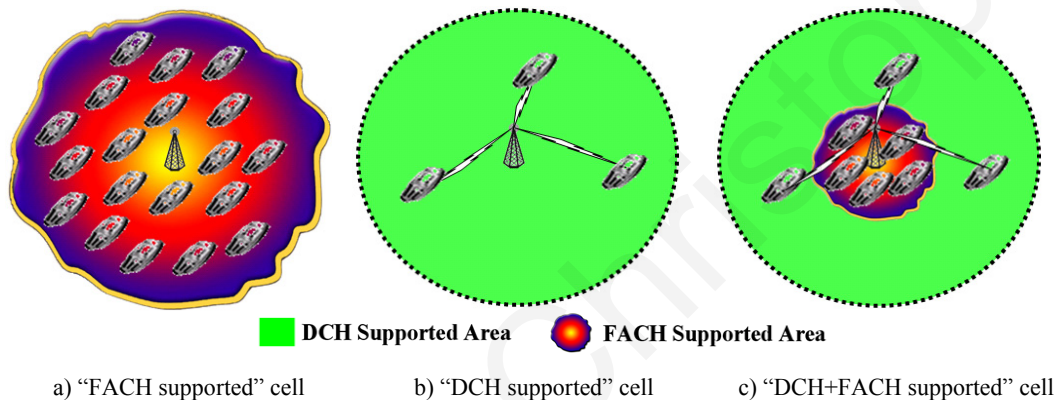

Figure 51 Ways in which an MBMS service maybe provided within a cell

Taking into consideration the ways an MBMS service can be provided within a cell, a mobile user that is on the move and receives an MBMS service, when crossing the cell’s edge will have to perform one of the following, during an inter-cell handover:

1. **Switch from DCH to DCH:** This type of inter-cell handover is likely to be performed if:
  - The MBMS user receives the MBMS service in the serving cell using DCH. For example, the type of the serving cell is either
    - “DCH supported”, or
    - “DCH+FACH supported” and the MBMS user lies in the “DCH supported area”.
  - The type of the best neighbouring cell (i.e. the target cell) is either:



- “DCH supported” or
  - “DCH+FACH supported”.
- 2. Switch from FACH to FACH:** This type of inter-cell handover is likely to be performed if both the serving and the target cells are “FACH supported”.
- 3. Switch from DCH to FACH:** This type of inter-cell handover is likely to be performed if:
- The MBMS user receives the MBMS service in the serving cell using DCH. For example, the type of the serving cell is either
    - “DCH supported”, or
    - “DCH+FACH supported” and the MBMS user lies in the “DCH supported area”.
  - The type of the best neighbouring cell is “FACH supported”.
- 4. Switch from FACH to DCH:** This type of inter-cell handover is likely to be performed if:
- The type of the serving cell is “FACH supported” (i.e., the MBMS user receives the MBMS service using FACH)
  - The type of the best neighbouring cell is either:
    - “DCH supported”, or
    - “DCH+FACH supported”.

The first type of inter-cell handover (switch from DCH to DCH), can be efficiently executed using the Soft Handover algorithm described and standardized by the 3GPP in [8] and [9], whilst, the second type of inter-cell handover (switch from FACH to FACH), can be efficiently executed using the Soft combining algorithm described in [2]. The third and fourth types of handovers (switch from DCH to FACH and vice versa) can be efficiently executed using the inter-cell handover algorithm we proposed in Chapter 3.

Since all of the aforementioned types of inter-cell handover have already been efficiently addressed, they will not be discussed further in this Chapter.

#### 4.7.4.2 Intra-cell Handovers

As indicated above, with the “Dual Transmission mode cell” concept, mobility issues arise in terms of intra-cell handovers that have to be addressed. More specifically a mobile user that receives an MBMS service and moves within a “DCH+FACH supported” cell, must be able to efficiently perform the following types of intra-cell handovers (see Figure 52):

- From “DCH supported area” to “FACH supported area” (i.e., switch from DCH to FACH within the same cell).
- From “FACH supported area” to “DCH supported area” (i.e., switch from FACH to DCH within the same cell).

Considering the aforementioned types of intra-cell handovers, an MBMS user moving within a “DCH+FACH supported” cell, indicates that is likely going to handover from the “DCH supported area” to the “FACH supported area” (i.e., switch from DCH to FACH within the cell) if:

- The MBMS user receives the MBMS service using DCH (i.e. is located within the “DCH supported area”).
- The CPICH  $E_c/N_0$  alteration rate experienced is increasing (indicating that the MBMS user is moving towards the Node-B and thus towards the “FACH supported area”)

On the other hand, an MBMS user moving within a “DCH+FACH supported” cell indicates that is likely going to handover from the “FACH supported area” to the “DCH supported area” (i.e., switch from FACH to DCH within the cell) if:

- The MBMS user receives the MBMS service using FACH (i.e., is located within the “FACH supported area”).
- The CPICH  $E_c/N_0$  alteration rate is decreasing (indicating that the MBMS user is moving away from Node-B and thus towards the “DCH supported area”)

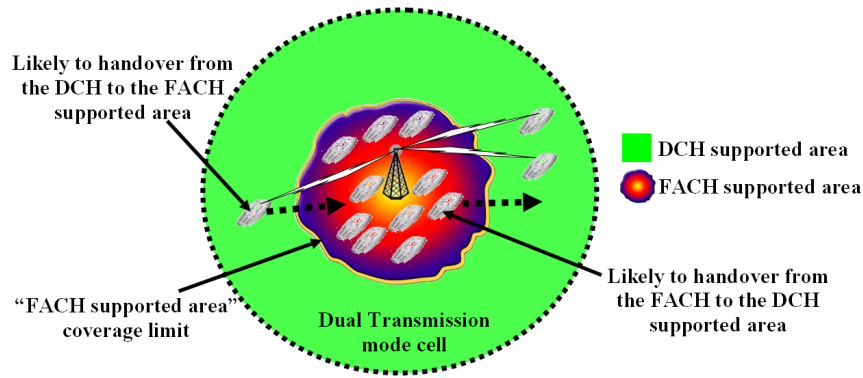

Figure 52 Types of intra-cell handovers that might occur in a “Dual Transmission mode cell”

To the best of our knowledge, in contrast with the inter-cell handover types referred above, these new types of intra-cell handovers have not been explored yet, since this is a new issue arising with the “Dual Transmission mode cell” concept. Thus, below we formulate a new intra-cell handover algorithm to efficiently address them. This algorithm will run in the UE and complement the radio resource allocation algorithm running in the RNC during its idle periods. Its role is to monitor and efficiently execute an intra-cell handover between the “FACH supported area” and the “DCH supported area” and therefore avoid any capacity or QoS inefficiencies from occurring.

#### 4.7.4.2.1 Proposed Intra-cell Handover algorithm

As indicated in section 4.5, the FACH provides capacity benefits but the QoS can be guaranteed only up to the “FACH supported area” coverage limit. Taking into consideration the aforementioned, it is obvious that in order to guarantee the required QoS throughout the intra-cell handover process while at the same time take full advantage of the capacity benefits that FACH can offer, the handover must be executed (i.e., switch from DCH to FACH, or vice versa) on the “FACH supported area” coverage limit (see Figure 52). This is also the aim of our intra-cell handover algorithm. It is worth mentioning that the inter-cell handover algorithm we proposed in Chapter 3 uses a similar approach but for executing a handover from DCH to FACH and vice versa, between different cells.

Thus, in our proposed intra-cell handover algorithm, similarly to the inter-cell handover algorithm described in Chapter 3, we introduced the “Pre-Trigger Predictor (PP)”, “Safety Margin (SM)”, “Safety time ( $St$ )”, “possibility  $p$  of erroneous handover triggering to occur”, “Activation Hysteresis (AH)”, “Activation time (At)”, “Handover Trigger Threshold (HTT)”, “Handover Activation Area (HAA)” and the “Handover Activation Threshold (HAT)”. The role of these parameters and how they are estimated is exactly the same as described in Chapter 3.

However, in order to facilitate efficient intra-cell handover execution, we further introduce the “Handover Information Table (HI\_Table)”. This Table will be created by the Network Operator during the Radio Network Planning and provided to the RNC. As shown in Table 15, the HI\_Table will include the following information:

- **Cell ID:** Uniquely identifying the cell that this HI\_Table is created for.
- **QoS ID:** Associating the HI\_Table with the MBMS service’s QoS requirements. The reason for associating an MBMS service with a QoS ID, is to reduce the number of the HI\_Tables required to be stored in the RNC. For example, instead of creating one HI\_Table for each MBMS service that can be made available in the cell, we create one HI\_Table for each group of MBMS services that have the same QoS requirements. These groups of MBMS services are associated with the same QoS ID and the same HI\_Table is used by the RNC for defining the thresholds that will be used if an intra-cell handover is likely to occur.
- **Safety time ( $St$ ) and Activation time (At):** The role of these two parameters is described in section 3.6.2.2 and 3.6.2.3, respectively.
- **“Initial” Activation Hysteresis (AH) threshold:** The role of the AH parameter is described in section 3.6.2.3. The initial AH is highly affected by the CPICH Ec/No alteration rate experienced by the UE during its mobility within the cell. In Figure 53, representative values concerning the CPICH Ec/No alteration rate experienced at different distances from the Node-B are provided for a pedestrian (~5 Km/h; Figure

53.b) and vehicular (~60 Km/h; Figure 53.c) operating environment. As illustrated, the CPICH Ec/No alteration rate is a parameter that varies at different distances from the Node-B (see Figure 53.a) and also with different operating environment. Thus for each Zone Area and for different operating environments, a different AH must be provided. These values will be estimated by the Network Operator during the Radio Network Planning. Based on the values illustrated in Figure 53, we provide in Table 15 example values for the initial AH for each Zone Area for a pedestrian outdoor operating environment. For vehicular operating environments these values will be higher.

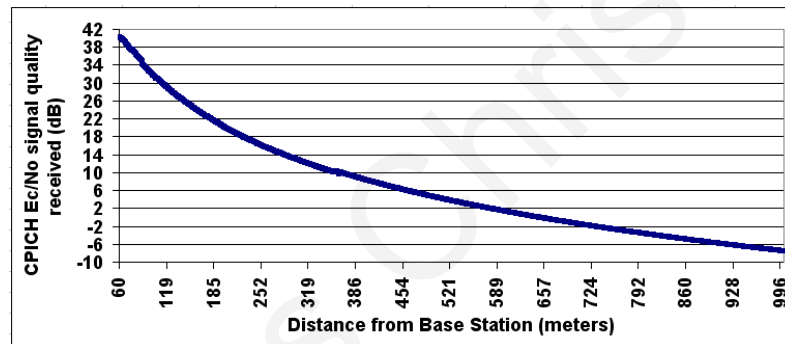

(a) CPICH Ec/No signal strength received at different distances from the Base Station

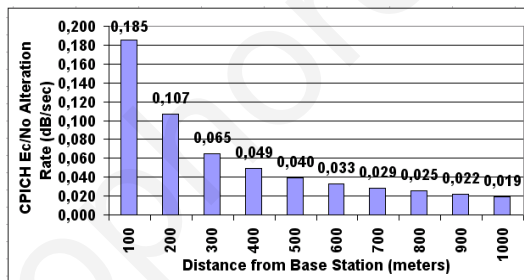

(b) Pedestrian outdoor environment - ~5 Km/h

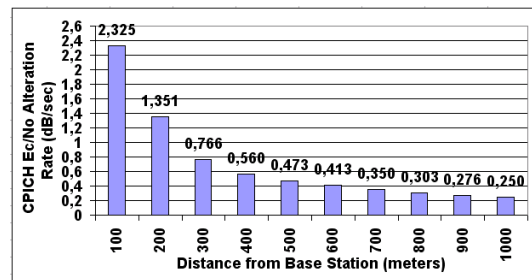

(c) Vehicular environment - ~60 Km/h

Figure 53 CPICH Ec/No Alteration rate experienced Vs Distance from the Node-B

Table 15 Handover Information Table (HI\_Table)

Cell ID (Identifying the Cell this HI Table is created for)		
QoS ID (Associating the HI Table with the MBMS service's QoS requirements)		
Safety time (St)		
Activation time (At)		
Zone Area	FACH supported area coverage limit (dB) (minimum CPICH Ec/No signal quality required to be received)	"Initial" Activation Hysteresis (dB) (for pedestrian outdoor environment)
ZA1	35 dB	0.8 dB
ZA2	21.5 dB	0.45 dB
ZA3	14 dB	0.3 dB
ZA4	9 dB	0.2 dB
ZA5	5 dB	0.2 dB
ZA6	1.8 dB	0.15 dB
ZA7	- 0.9 dB	0.15 dB
ZA8	- 3.3 dB	0.1 dB
ZA9	- 5.4 dB	0.1 dB
ZA10	- 7.2 dB	0.1 dB

Since in one cell more than one MBMS services with different QoS requirements can be made available, one HI\_Table will be created for each group of MBMS service that has the same QoS requirements and will be uniquely identified using the Cell's ID and the QoS ID mapped to these QoS requirements.

Once, the Transmission Arrangement that will be used for the provision of the MBMS service within the cell is decided, the RNC, based on the Zone Area selected to be supported using FACH (this is indicated in the CCIT created for the specific MBMS service within the cell), locates the HI\_Table related to the specific cell (using the Cell's ID) and the MBMS service (using the QoS ID mapped to the MBMS service's QoS requirements) and acquires the values of the parameters that should be considered during the estimation of the *Handover Activation Threshold (HAT)* and *Handover Trigger Threshold (HTT)*. These parameters are:

- The FACH supported area coverage limit of the related Zone Area (i.e., the **minimum CPICH Ec/No signal quality required** to be measured by the UE for indicating a reliable reception of the MBMS service using FACH),
- The **initial Activation Hysteresis (AH)** related to the Zone Area,
- The **Activation time (At)**, and
- The **Safety time (St)**.

These parameters will be broadcast to the UEs within the cell through the MCCH. Since the MCCH already includes information in relation to the MBMS services supported in the current cell [9] (*MBMS Current Cell P-t-M Radio Bearer Information*), the *MBMS Current Cell P-t-M Radio Bearer Information* must be enhanced in order to support for each MBMS service that is currently provided with the cell the following parameters:

- FACH supported area coverage limit (1 byte)
- Activation Hysteresis (AH) (1 byte)
- Activation time (At) (1 byte)
- Safety time (St) (1 byte)

The aforesaid outlines the main concept of our proposed intra-cell handover algorithm and also the parameters and thresholds vital for the efficient intra-cell handover execution are discussed. Next we present the details of our algorithm.

#### 4.7.4.2.1.1 Description

Similarly to the inter-cell handover algorithm described in Chapter 3, in order to minimise execution time overhead the main algorithm is activated only when the MBMS user is inside the “*Handover Activation Area (HAA)*”. Therefore, the proposed intra-cell handover algorithm is divided into two phases:

- **Phase 1:** Outside of the Handover Activation Area (HAA)
- **Phase 2:** Inside the Handover Activation Area (HAA)

Phase 2 is further divided into two more steps that are initiated based on two thresholds:

- **Activation Step:** Initiated by the Handover Activation Threshold (HAT)
- **Trigger Step:** Initiated by the Handover Trigger Threshold (HTT)

In order to simplify exposition of the proposed intra-cell handover approach description, we consider the case where the UE is receiving the MBMS service in the “DCH+FACH” supported cell using FACH (i.e., the UE is located in the “FACH supported area”) and moving towards the “DCH supported area” (see Figure 54). Note that a similar logic can be

applied with the vice versa case of intra-cell handover (from “DCH supported area” to “FACH supported area”), too.

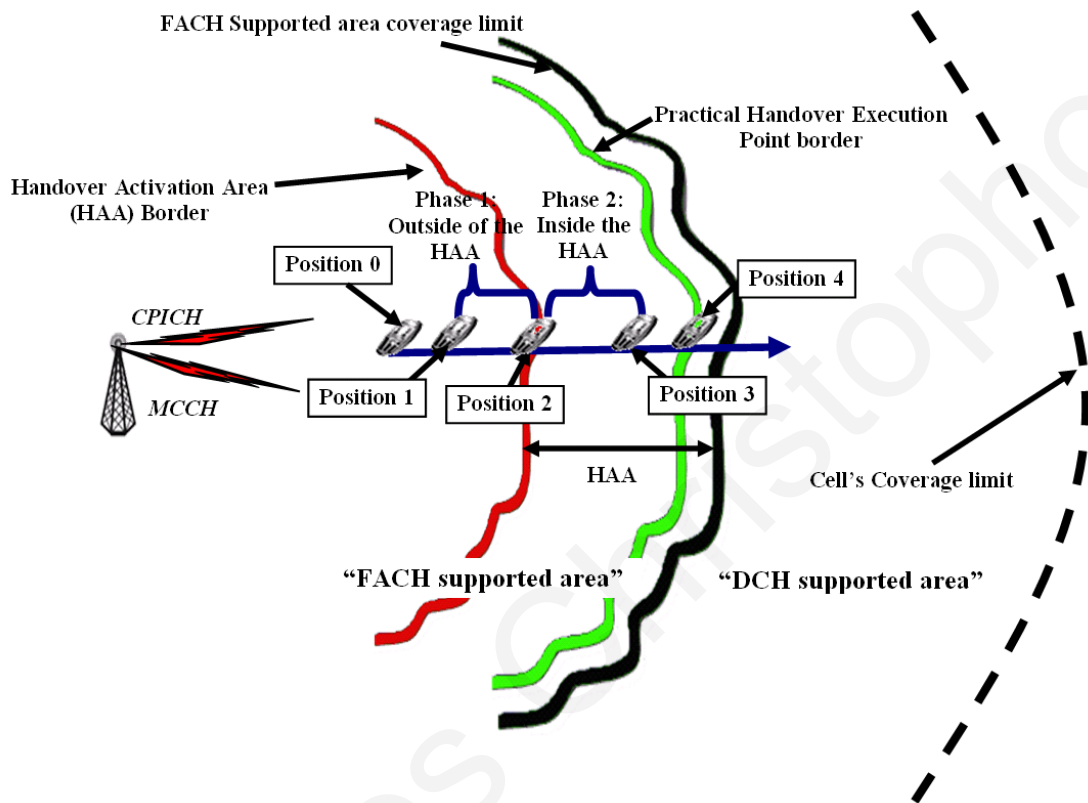

Figure 54 Proposed intra-cell handover algorithm description

### **Phase 1: Outside of the Handover Activation Area (HAA)**

The UE receives the MBMS service using FACH (i.e., is located in the “FACH supported area”) and the CPICH  $E_c/N_0$  alteration rate experienced from its serving cell is decreasing (i.e., the UE is moving away from the cell’s Node-B and thus towards the “DCH supported area”). This indicates to the UE that an intra-cell handover from the “FACH supported area” to the “DCH supported area” is likely to occur.

Upon indicating that (say Position 0), the UE reads the MCCH and acquires the value designating the FACH’s supported area coverage limit (i.e., the *minimum CPICH  $E_c/N_0$  required* to be received by the UE for indicating a reliable reception of the MBMS service



using FACH) and the *initial Activation Hysteresis (initial AH)* value set by the Network Operator and estimates the *initial Handover Activation Threshold (initial HAT)*.

Once estimated, and assuming that the same status remains (i.e., the Transmission Arrangement used for the provision of the MBMS service within the cell remains the same), the *initial HAT* is continually compared with instantaneous CPICH Ec/No signal quality measured from the serving cell. Note that the *initial HAT* is estimated only once.

When the instantaneous CPICH Ec/No signal quality measured from the serving cell becomes equal to or weaker than the *initial HAT*, the algorithm will dynamically regulate the *Activation Hysteresis* and moreover the *Handover Activation Threshold (HAT)*, by considering the mobility of the UE (i.e., the instantaneous CPICH Ec/No alteration rate experienced by the UE) and the “*Activation time (At)*” broadcast through the MCCH within the cell.

Thus, once the *initial HAT* is reached (Position 1), and while the instantaneous CPICH Ec/No signal quality measured from the serving cell is weaker than the *initial HAT*, the algorithm, dynamically regulates the *AH* value based on the motion of the user (i.e., the CPICH Ec/No alteration rate experienced by the UE) and the *At* time and adjusts the size of the *Handover Activation Area (HAA)* accordingly. Every time the *AH* value is regulated a *new HAT* value is estimated.

The *new HAT* value is then compared with the instantaneous CPICH Ec/No signal quality measured from the serving cell. When measured CPICH Ec/No signal quality becomes *equal to or weaker than ( $\geq$ ) the new HAT* (Position 2), the algorithm transits to Phase 2, otherwise remains in Phase 1.

Note that once transiting to Phase 2, the dynamic regulation of the *AH* value and thus the dynamic estimation of the *HAT* value will stop. The *Handover Activation Area border* will then be defined based on the *latest HAT* value estimate.

**Notes:** In order to further reduce the processing effort required by the UE for the dynamic estimation of the HAT, this threshold will be estimated only when:

- A change occurs on the CPICH Ec/No alteration rate experienced by the UE. Otherwise there is no need to re-estimate it since the new value will be equal to the one previously estimated.
- The CPICH Ec/No alteration rate experienced by the UE from the serving cell is decreasing (i.e., the UE is moving away from the “FACH supported area”). Otherwise, there is no need to be estimated since the MBMS user is either stable or moving towards the Node-B and thus an intra-cell handover from the FACH to the DCH supported area is not likely to occur.

Similar logic is applied with the vice versa case of intra-cell handover (i.e., from the “DCH supported area” towards the “FACH supported area”).

### **Phase 2: Inside the Handover Activation Area (HAA)**

**Activation Step:** This step is activated automatically upon transition to Phase 2 (Position 2) and indicates to the UE that it has entered the “*Handover Activation Area (HAA)*”. The UE upon entering this area starts the estimation of the *Handover Trigger Threshold (HTT)*. Note that the value of the *HTT* will be estimated similarly to the way described in section 3.6.3

Therefore, the UE during its mobility within the *Handover Activation Area (HAA)* will continually estimate the *Handover Trigger Threshold (HTT)* and compare it with the measured CPICH Ec/No signal quality received from the serving cell. When the measured CPICH Ec/No signal quality becomes *equal to* or *weaker than* the *HTT* (Position 3) it will transit to the *Trigger Step* in which the intra-cell handover is triggered.

Note that from within the *Activation Step*, if the CPICH Ec/No signal quality measured by the UE from the serving cell becomes greater than the *latest HAT* value (meaning that the UE has left the *Handover Activation Area (HAA)*) then the algorithm goes back to Phase 1.

**Notes:** In order to further reduce the processing effort required by the UE, the *Handover Trigger Threshold (HTT)* will be estimated only when:

- A change occurs on the CPICH Ec/No alteration rate experienced by the UE. Otherwise there is no need to re-estimate it since the new value will be equal to the one previously estimated.
- The CPICH Ec/No alteration rate experienced by the UE from the serving cell is decreasing (i.e., the UE is moving away from the “FACH supported area”). Otherwise, there is no need to be estimated since the MBMS user is either stable or moving towards the Node-B and thus an intra-cell handover from the FACH to the DCH supported area is not likely to occur.

**Trigger Step:** The UE prepares the handover request and triggers the handover by sending the handover request to the RNC (Position 3). The RNC processes the request and executes the handover (Position 4).

The intra-cell handover algorithm we described above uses exactly the same approach as the one we described in Chapter 3. Thus, the same flowcharts illustrated in Figure 22 can be used to describe the steps and activities that will be performed in case the MBMS user is likely to handover from the “DCH supported area” to the “FACH supported area” (see Figure 22.a), or in case the MBMS user is likely to handover from the “FACH supported area” to the “DCH supported area” (see Figure 22.b).

#### **4.7.5 Processing - Memory requirements and Signalling Overhead**

In this section we briefly analyze the processing and memory requirements (both in UE and RNC) and the signalling overhead introduced in the radio interface when our proposed “Dual Transmission mode cell” MBMS service provision approach is applied.

### **Processing effort introduced in the UE:**

#### ***Processing effort introduced with intra-cell handover algorithm:***

The proposed intra-cell handover algorithm uses exactly the same approach as the one used by the inter-cell handover algorithm we proposed in Chapter 3. Thus, the same processing effort as described in section 3.6.4 is introduced for the estimation of the thresholds and parameters required (i.e., “Handover Activation Threshold (HAT)”, “Handover Trigger Threshold (HTT)”, “Pre-Trigger Predictor (PP)”, “Activation Hysteresis (AH)”, “Safety Margin (SM)”, etc.) for the efficient intra-cell handover execution.

#### ***Processing effort introduced with “Dual Transmission mode cell” approach:***

With our proposed “Dual Transmission mode cell approach” the UE has to periodically create reports about its instantaneous context and send it to the RNC. For this report the UE will have to measure the instantaneous channel quality received (which is already measured by the UE for handover purposes) and also the channel quality alteration rate (which is also already estimated by the UE for handover purposes) experienced from the serving and Best Neighbouring cell and store the related values (note that only 1.5 clock cycles are required for storing a value; see [44]) to the related fields in the report. Thus trivial processing effort is required here.

### **Memory requirements in the UE:**

#### ***Amount of memory required for intra-cell handover purposes:***

Since the proposed intra-cell handover algorithm uses the same approach as the one used by the inter-cell handover algorithm described in Chapter 3, the memory requirements in the UE are the same as those described in section 3.6.4. However, in this case there is no need to store in its memory the values indicating the FACH supported area coverage limit, the initial Activation Hysteresis, the Safety time ( $S_t$ ) and the Activation time ( $A_t$ ), since the values of these parameters will be acquired from the MCCH broadcast within the cell.

***Amount of memory required for “Dual Transmission mode cell” approach:***

During its mobility, the UE will have to estimate and store in its memory the following values that will be reported to the RNC:

- CPICH Ec/No signal quality measured from serving cell (1 byte)
- CPICH Ec/No alteration rate experienced from serving cell (1 byte)

If the UE is close to the cell’s edge and an inter- cell handover is likely to occur it will also have to estimate and store in its memory the following.

- Best Neighbouring Cell’s ID (2 bytes)
- CPICH Ec/No signal quality measured from best neighbouring cell (1 byte)
- CPICH Ec/No alteration rate experienced from best neighbouring cell (1 byte)

Taking into account that the storage capacity of newer mobile phones can reach Gbytes, the amount of memory required in the UE (only 6 bytes) is trivial.

**Processing effort introduced in the RNC:**

***Processing effort introduced with “Dual Transmission mode cell” approach:***

The RNC, periodically during the session, based on the context information included in the CCITs has to perform the following activities:

- Form all possible transmission arrangements that can be used for each MBMS service within each cell that the MBMS service can be made available,
- Estimate the transmission power required for each, and
- Select the one that is considered as the most efficient to be adopted.

The different Transmission Arrangements that can be used (i.e., the FACH and DCH subgroups), are formed by having the algorithm estimate for each UE that a context report is received from, the *instantaneous CPICH Ec/No signal quality + (CPICH Ec/No Alteration rate x “QoS Safety time”)* and comparing it with the value (i.e., the *minimum CPICH Ec/No*

*required*) indicating the coverage limit of each Zone Area (in order to indicate the Zone Area that the UE belongs to). Note that our proposed context reporting request process reduces significantly the amount of UEs that have to report. As illustrated in the performance evaluation section (see 4.8), for all scenarios used, irrespective of the number of UEs present in the cell, on average only a very small number of UEs (about 9) have to report every time the context reporting request process is initiated, for a decision to be made.

However, in the analysis below we assume that more UEs, for arguments sake we will assume a maximum of 50 UEs, will have to report for a Transmission Arrangement decision to be made. Moreover, an RNC by definition needs to divide its limited processing resources among many base stations. Typically, this means that a single RNC can only support a few hundred Base Stations. Thus, assuming that an RNC can support 500 Node-Bs (i.e., cells), the MBMS service is provided in all these cells and 50 UEs have to report in each cell, then a maximum of 25,000 reports (i.e., UEs) will be considered by the RNC for the formation of all Transmission Arrangements that can be used in all the cells (note that this can be considered as the worst case scenario that can occur)

Since, as indicated above, for each report received by a UE, in order to indicate the Zone Area that the UE belongs to, one addition (3 clock cycles), one multiplication (5 clock cycles) and 200 comparisons<sup>8</sup> (one for each Zone Area that the cell is divided into – 3 clock cycles for each compare instruction), a total of **15,200,000 clock cycles** (i.e., 25,000 reports x 608 clock cycles) will have to be performed for the formation of all transmission arrangements that can be used for the MBMS service within all these 500 Node-Bs (cells). This amount of clock cycles have been estimated considering the Intel Technical documents [44]. In addition, when a report is received by the RNC, the RNC will have to store the values included in the report in the related MBMS user's record in the CCIT. Assuming that 5 values will have to be stored in the MBMS user's record in the CCIT for each report received (note that only 1.5 clock

---

<sup>8</sup> Note that this is the worst case since in order for all 200 comparisons to be performed the UE will have to be not more than 10 meters away from the Node between floating numbers are made

cycles are required for storing or retrieving a value; see [44]), a total of **375,000 clock cycles** will be required for retrieving the values included in the report and storing them in the related fields in the CCIT.

Moreover, for the estimation of the capacity required for each Transmission Arrangement, the RNC will have to add the power required for each UE in case a DCH is established with the power required by FACH in order to cover a certain area of the cell. Assuming again 500 Node-Bs, each divided in 200 Zone Areas, and 50 UEs that reported in each cell (i.e., a total of 25,000 reports) a total of 125,000 additions (500 Node-Bs x 200 Zone Areas + 25,000 total number of reports) will have to be performed. Thus a total of **375,000 clock cycles** will be performed for the estimation of the transmission power required for each transmission arrangement in each cell.

For the selection of the most efficient Transmission Arrangement (i.e., the one that requires the less transmission power consumption) that will be adopted, the algorithm will have to compare the capacity requirements of each transmission arrangement formed. With a cell divided in 200 Zone Areas, a total of 201 Transmission Arrangements can be formed. Thus a total of 200 comparisons will be required for the selection of most efficient Transmission Arrangement within the cell. Assuming again 500 Node-Bs, a total of 100,000 comparisons will have to be made (this is the worst case scenario). Thus a total of **300,000 clock cycles** will be required for the selection of the Transmission Arrangement that will be adopted in the all the cells that the RNC supports.

Thus **at worst a total of 16,250,000 clock cycles** will be required (note that above we considered the worst case scenario) for the formation of all Transmission Arrangements, the estimation of the transmission power requirements for each and the selection of the most efficient one to adopt. Considering that the RNC is a powerful server with more than one CPU and each with power of some GHz (i.e. billions of clock cycles per second), the above will be performed in a few milliseconds. For example assuming an **Intel Xeon processor 7,500**

series with 3.33GHz CPU, only the 0.5% of the total RNC' processing power will be used and the final decision will be performed in no more than **4.88 ms**.

***Processing effort introduced with intra-cell handover algorithm:***

With the proposed intra-cell handover approach the RNC will have to estimate the handover delay time ( $\Delta t$ ) and broadcast it through the MCCH to the UEs within the cell. However, the estimation of the  $\Delta t$  requires marginal computational effort since the RNC in order to estimate this parameter will just average the  $\Delta t$  experienced by other UEs at the current time of the request.

Moreover, the RNC, once the Transmission Arrangement that will be used for the provision of the MBMS service in each cell is decided, must acquire from the related HI\_Tables, the values indicating the FACH supported area coverage limit and the initial Activation Hysteresis parameters related to the Zone area decided to the supported using FACH as well as the Safety time ( $S_t$ ) and Activation time ( $A_t$ ) parameter and broadcast them through the MCCH in each cell that the MBMS service can be made available. However, locating the related HI\_Table and acquiring the aforementioned values also requires marginal computational effort.

**Memory requirements in the RNC:**

***Amount of memory required for “Dual Transmission mode cell” approach:***

For each cell that the RNC controls, it must store for each MBMS service that is currently made available within the cell a Cell Context Information Table (CCIT) in which the instantaneous context of the UEs receiving the specific MBMS service will be included. As indicated above, an RNC can only support a few hundred Node-Bs. Thus, assuming that an RNC can support 500 Node-Bs, it will have to store up to 500 CCITs for one each MBMS service. Note that our proposed context reporting request process reduces significantly the amount of UEs that have to report in each cell. Here we assume that in each cell, 50 UEs have



to report (at worst). Thus, a total of 25,000 users' records will have to be stored in the CCITs. Considering that 16 bytes are required for each MBMS user's record (see section 4.7.1.1.1), a total of **400,000 bytes** (400 Kbytes) are considered enough to store the required context information (i.e., the MBMS users' records) in the CCITs for one MBMS service. Moreover each CCIT includes some information related to the MBMS service which is 78 bytes in total, making it a total of **39,000 bytes (39 Kbytes)**. Thus a total of **439 Kbytes** are considered enough to store the required information in the CCITs for one MBMS service. Assuming that 50 MBMS services can be made available at the same time (which can be considered an extreme scenario), a total of **21.95 Mbytes** are required for storing the CCITs for all the MBMS services.

Moreover, the RNC will also have to store, for each cell, a FACH Information Table (FACH\_IT) that will be considered during the formation and the transmission power requirements of the different transmission arrangements. This table includes the FACH supported area coverage limit (1 byte) of each Zone Area and the power required to be devoted to FACH (1 byte) for reliably supporting this Zone Area. Assuming the extreme case where all the cells are divided into 200 Zone Areas, a total of **403 bytes** (2 bytes x 200 Zone Areas + 3 bytes for additional information) will be required to be allocated for each FACH\_IT. Moreover, since more than one MBMS services with different QoS requirements can be available in the cell, different FACH\_ITs will have to be associated with MBMS services with different QoS. It is important to indicate here that the RNC will store only the FACH\_ITs related to cells that it controls (which we assumed to be 500 Node-Bs). Thus, considering again the case of an RNC controlling 500 Node-Bs, in which 50 MBMS services with different QoS requirements can be available, 25,000 distinct FACH\_ITs (500 Node-Bs x 50 MBMS services) have to be stored in the RNC. Thus a total of 10,075,000 bytes (**10.075 Mbytes**) is considered enough for storing all the required FACH\_ITs in the RNC.

***Amount of memory required for intra-cell handover algorithm:***

For each cell, a Handover Information Table (HI\_Table) in which the parameters essential for the estimation of the HAT and the HTT thresholds will be stored. These are the value indicating the FACH supported area coverage limit (1 byte) and the initial Activation Hysteresis (1 byte) value. Assuming again the case where all the cells are divided into 200 Zone Areas, the total memory required to be allocated for each HI\_Table is **405 bytes** (2 bytes x 200 Zone Areas + 5 bytes for additional information).

Moreover, since more than one MBMS service with different QoS requirements can be available in the cell, different HI\_Tables will have to be associated with MBMS services with different QoS. It is important to indicate here that the RNC will store only the HI\_Tables related to cells that it controls (which we assumed to be 500 Node-Bs). Thus, considering again the case of an RNC controlling 500 Node-Bs, in which 50 MBMS services with different QoS requirements can be available, 25,000 distinct HI\_Tables have to be stored in the RNC, requiring a total of 10,125,000 bytes (**10.125 Mbytes**) for storing the required HI\_Tables in the RNC.

Thus a total of **42.15 Mbytes** are considered more than enough to store the CCITs, the FACH\_ITs and the HI\_Tables required in the RNC. Taking into account that the storage capacity of the RNC can reach Terabytes, the amount of memory required in the RNC (some Megabytes) is trivial.

**Signalling Overhead introduced:**

With the proposed approach the RNC must broadcast through the MCCH for each MBMS service that can be provided (in parallel) within the cell the following parameters:

- FACH supported area coverage limit (1 byte)
- Initial Activation Hysteresis (1 byte)
- Safety time (St) (1 byte)

- Activation time (At) (1 byte)
- QoS Safety time (1 byte)

By considering that more than 30% of the Node-B's total power has to be allocated to a single 64 Kbps MBMS service if full coverage is needed (see [7]) up to three or four MBMS streaming services can be made available in parallel within a cell. Thus, the signalling overhead that can be introduced in the downlink (i.e., in the MCCH) by our proposed approach in each cell is only up to a total of 20 bytes.

#### **4.8 Performance Evaluation**

Our proposed "Dual Transmission mode cell" approach has been implemented (see Appendix C) and evaluated in the MBMS simulator [45]. This simulator was created during the B-BONE project using as a base the UMTS module provided by OPNET Modeller 11.0.A simulation tool [46]. In order to illustrate the performance of our proposed approach compared to other related approaches, we also implemented in the same simulator the "UE Counting" [2], the "Power Counting" [10], the "Rate Splitting" [12] and the "FACH with Power Control" [14] approaches. The scenarios used for the evaluation are described in section 4.8.1, while the results obtained are analyzed in section 4.8.2.

##### **4.8.1 Scenarios Description**

For the performance evaluation, four scenarios have been simulated. Note that since inter-cell handovers are not in the scope of this research, all the scenarios simulated are one-cell scenarios.

Scenario 1, 2 and 3 are used for illustrating the feasibility, the gains that can be achieved, and the usefulness of our proposed approach during the MBMS service provisioning in a pedestrian (speeds from 5 – 7 Km/h), low vehicular (speeds of 30 – 40 Km/h) and high vehicular (speeds of 60 – 70 Km/h) urban environments. Each of these scenarios have been simulated applying the "UE counting", the "Power Counting", the "Rate Splitting", the "FACH with Power Control" and our proposed "Dual Transmission mode cell" approach,

respectively. The performance of our proposed Dual Transmission mode cell scheme was evaluated and compared against the other related approaches using:

- Downlink capacity (transmission power) requirements,
- Downlink channel quality experienced by the UE,
- Terminal battery consumption, uplink interference caused,
- Total number of UEs required to report for a decision to be made,
- Time required for context reporting request process to finish.

Scenario 4, on the other hand, is used in order to illustrate the additional benefits that we can have on the downlink transmission power requirements for unicast services when a mix of other unicast services like ftp, email, http browsing, unicast streaming video(of 64kbits/sec) are used in the cell, when our approach is applied.

The use of these scenarios is justified in Table 16.

*Table 16 MBMS service provision– Scenarios selected*

<b>Scenario 1</b>	This scenario considers the case where users are located in the shopping centre and walk randomly doing their shopping. During their mobility within the cell (that the shopping centre is located) the users receives a 64 Kbits/sec MBMS video clip advertising the different shops as well as the special offers that each shop provides. The aim of this scenario is to illustrate the gains that can be achieved by our proposed approach in a pedestrian urban environment.
<b>Scenario 2</b>	This scenario considers the case where users, located in the city centre, just finish their work and got into their car (in the parking place) to go home. The users are moving randomly (with a low vehicular speed) trying to get out of the parking place and once outside they start moving at different directions towards their home. During this time some users are receiving an MBMS streaming video of 64 Kbits/sec with the main news of the day. The aim of this scenario is to illustrate the gains that can be achieved by our proposed approach in a low vehicular urban environment.
<b>Scenario 3</b>	This scenario is similar to scenario 2, but in this case we assume that the users receiving the 64 Kbits/sec MBMS streaming video (the main news of the day) have already left the parking place and are heading towards their home with higher speed. The aim of this scenario is to illustrate the gains that can be achieved by our proposed approach in a vehicular urban environment.
<b>Scenario 4</b>	This scenario is similar to scenario 1 but in this case, in addition to the 64 Kbits/sec MBMS video clip advertising the shops of the shopping centre, a mix of other unicast

	services (i.e., ftp, http, email, unicast streaming video) are used. The aim of this scenario is to illustrate the additional downlink capacity gains that can be achieved on the unicast services received by some of the other users moving randomly in the shopping centre (due to the reduction of the intra-cell interference achieved when our proposed approach is applied).
--	---

Scenario 1 is further described in section 4.8.1.1, scenario 2 in section 4.8.1.2 scenario 3 in section 4.8.1.3 and scenario 4 in section 4.8.1.4.

#### **4.8.1.1 Scenario 1: Pedestrian urban environment**

In this scenario all the MBMS users are placed randomly within the cell and receive a 6 minute duration MBMS streaming video clip. All MBMS users are set to move randomly within the cell, with a speed between 5 and 7 Km/hour. This scenario has been simulated using a high loaded (70 MBMS users), a medium loaded (40 MBMS users) and a low loaded (20 MBMS users) cell. The simulation parameters used are illustrated in Table 17. The results collected are compared and analysed in section 4.8.2.1.

Table 17 Simulation Parameters – Scenario 1: Pedestrian urban environment

Simulation Parameter	Value
Traffic used	64 Kbits/sec MBMS Streaming video clip, Duration: 6 minutes
Propagation environment	Urban Pedestrian Outdoor
UEs' speed	5 – 7 Km/hour (1.38 – 1.94 meters/sec)
Cell radius	1000 meters
Node-B Antenna type	Omnidirectional
Shadow fading	Standard deviation log-normal of 10 dB
Transmission Time Interval (TTI)	20 ms
Channel coding	Convolutional 1/3 coding rate
Downlink Other-cell Interference factor	1.78
Thermal Noise power spectral density	-174 dBm
Orthogonality factor	0.5
Dual Transmission mode cell	Zone Areas: 50 Periodicity of Reporting: 8 seconds (accommodate mobility every ~15 meters of the UEs movements) QoS Safety time: 11 seconds (used in order to lessen the possibility of frequent intra-cell handovers) Safety time: 2 seconds (used for intra-cell handovers)
UE Counting approach	UE Counting Threshold: 6 UEs Periodicity of Reporting: 8 seconds (accommodate mobility every ~15 meters of the UEs movements)
Rate splitting	First FACH: Base Layer 32Kbits/sec covering the whole cell Second FACH: Enhancement Layer 32Kbits/sec covering 700 meters of the cell's coverage Periodicity of Reporting: 8 seconds (accommodate mobility every ~15 meters of the UEs movements)
Power Counting	Periodicity of Reporting: 8 seconds (accommodate mobility every ~15 meters of the UEs movements)
FACH with power control	Periodicity of reporting: 2 seconds (every ~4 meters) Only UEs that are further than 500 meters from the Node-B are set to report

#### 4.8.1.2 Scenario 2: Low vehicular urban environment

In this scenario all the MBMS users are placed randomly within the cell and receive a 3 minute duration MBMS streaming video clip. All MBMS users are set to move randomly within the cell, with a speed between 30 and 40 Km/hour. This scenario has been simulated using a high loaded (70 MBMS users), a medium loaded (40 MBMS users), and a low loaded (20 MBMS users) cell. The simulation parameters used are illustrated in Table 18. The results collected are compared and analysed in section 4.8.2.2.

Table 18 Simulation Parameters – Scenario 2: Low vehicular urban environment

Simulation Parameter	Value
Traffic used	64 Kbits/sec MBMS Streaming video clip, Duration: 3 minutes
Propagation environment	Urban Low vehicular
UEs' speed	30 – 40 Km/hour (8.33 – 11.11 meters/sec)
Cell radius	1000 meters
Node-B Antenna type	Omnidirectional
Shadow fading	Standard deviation log-normal of 10 dB
Transmission Time Interval (TTI)	20 ms
Channel coding	Convolutional 1/3 coding rate
Downlink Other-cell Interference factor	1.78
Thermal Noise power spectral density	-174 dBm
Orthogonality factor	0.5
Dual Transmission mode cell	Zone Areas: 50 Periodicity of Reporting: 2 seconds (accommodate mobility every ~17 meters of the UEs movements) QoS Safety time: 5 seconds (used in order to lessen the possibility of frequent intra-cell handovers) Safety time: 2 seconds (used for intra-cell handovers)
UE Counting approach	UE Counting Threshold: 6 UEs Periodicity of Reporting: 2 seconds (accommodate mobility every ~17 meters of the UEs movements)
Rate splitting	First FACH: Base Layer 32Kbits/sec covering the whole cell Second FACH: Enhancement Layer 32Kbits/sec covering 700 meters of the cell's coverage Periodicity of Reporting: 2 seconds (accommodate mobility every ~17 meters of the UEs movements)
Power Counting	Periodicity of Reporting: 2 seconds (accommodate mobility every ~17 meters of the UEs movements)
FACH with power control	Periodicity of reporting: 0.5 seconds (every ~5 meters) Only UEs that are further than 500 meters from the Node-B are set to report

#### 4.8.1.3 Scenario 3: Vehicular urban environment

In this scenario all the MBMS users are placed randomly within the cell and receive a 2 minute duration MBMS streaming video clip. All MBMS users are set to move randomly within the cell, with a speed between 60 and 70 Km/hour. This scenario has been simulated using a high loaded (70 MBMS users), a medium loaded (40 MBMS users), and a low loaded (20 MBMS users) cell. The simulation parameters used are illustrated in Table 19. The results collected are compared and analysed in section 4.8.2.3.

Table 19 Simulation Parameters – Scenario 3: Vehicular urban environment

Simulation Parameter	Value
Traffic used	64 Kbits/sec MBMS Streaming video clip, Duration:2 minutes
Propagation environment	Urban vehicular
UEs' speed	60 – 70 Km/hour (16.66 – 19.44 meters/sec)
Cell radius	1000 meters
Node-B Antenna type	Omnidirectional
Shadow fading	Standard deviation log-normal of 10 dB
Transmission Time Interval (TTI)	20 ms
Channel coding	Convolutional 1/3 coding rate
Downlink Other-cell Interference factor	1.78
Thermal Noise power spectral density	-174 dBm
Orthogonality factor	0.5
Dual Transmission mode cell	Zone Areas: 50 Periodicity of Reporting: 0.8 seconds (accommodate mobility every ~16 meters of the UEs movements) QoS Safety time: 4 seconds (used in order to lessen the possibility of frequent intra-cell handovers) Safety time: 2 seconds (used for intra-cell handovers)
UE Counting approach	UE Counting Threshold: 6 UEs Periodicity of Reporting: 0.8 seconds (accommodate mobility every ~16 meters of the UEs movements)
Rate splitting	First FACH: Base Layer 32Kbits/sec covering the whole cell Second FACH: Enhancement Layer 32Kbits/sec covering 700 meters of the cell's coverage Periodicity of Reporting: 0.8 seconds (accommodate mobility every ~16 meters of the UEs movements)
Power Counting	Periodicity of Reporting: 0.8 seconds (accommodate mobility every ~16 meters of the UEs movements)
FACH with power control	Periodicity of reporting: 0.2 seconds (every ~4 meters) Only UEs that are further than 500 meters from the Node-B are set to report

#### 4.8.1.4 Scenario 4: Pedestrian urban environment using MBMS and unicast traffic

In this scenario all the MBMS users are placed randomly within the cell and receive a 6 minute duration MBMS streaming video clip. All MBMS users are set to move randomly within the cell, with a speed between 5 and 7 Km/hour. This scenario has been simulated assuming 40 MBMS users receiving a streaming video of 64 Kbits/sec and another 30 users receiving other unicast services like ftp, http, email and unicast streaming video (of 64 Kbits/sec) traffic. The simulation parameters used are illustrated in Table 20. The results collected are compared and analysed in section 4.8.2.4.

Table 20 Simulation Parameters – Scenario 4: Pedestrian urban environment with mix traffic



Simulation Parameter	Value
Traffic used	64 Kbits/sec MBMS Streaming video clip, Duration: 6 minutes 7 FTP users, 8 Email users, 10 Http users, 5 unicast streaming video of 64 Kbits/sec users
Propagation environment	Urban Pedestrian Outdoor
UEs' speed	5 – 7 Km/hour (1.38 – 1.94 meters/sec)
Cell radius	1000 meters
Node-B Antenna type	Omnidirectional
Shadow fading	Standard deviation log-normal of 10 dB
Transmission Time Interval (TTI)	20 ms
Channel coding	Convolutional 1/3 coding rate
Downlink Other-cell Interference factor	1.78
Thermal Noise power spectral density	-174 dBm
Orthogonality factor	0.5
Dual Transmission mode cell	Zone Areas: 50 Periodicity of Reporting: 8 seconds (accommodate mobility every ~15 meters of the UEs movements) QoS Safety time: 11 seconds (used in order to lessen the possibility of frequent intra-cell handovers) Safety time: 2 seconds (used for intra-cell handovers)
UE Counting approach	UE Counting Threshold: 6 UEs Periodicity of Reporting: 8 seconds (accommodate mobility every ~15 meters of the UEs movements)
Rate splitting	First FACH: Base Layer 32Kbits/sec covering the whole cell Second FACH: Enhancement Layer 32Kbits/sec covering 700 meters of the cell's coverage Periodicity of Reporting: 8 seconds (accommodate mobility every ~15 meters of the UEs movements)
Power Counting	Periodicity of Reporting: 8 seconds (accommodate mobility every ~15 meters of the UEs movements)
FACH with power control	Periodicity of reporting: 2 seconds (every ~4 meters) Only UEs that are further than 500 meters from the Node-B are set to report

## 4.8.2 Analysis of Results

### 4.8.2.1 Scenario 1: Pedestrian urban environment

The results collected from Scenario 1, relate to the tradeoffs and the gains achieved by each approach in a pedestrian urban environment. The results collected compare the capacity requirements, the channel quality experienced, the terminal's battery consumption (due to reporting), the total number of UEs that are required to report, the time required for the context reporting request process to finish (and thus the time required for the final decision to be made) and the uplink interference caused, by each approach.

**Capacity (Downlink power) requirements and Channel Quality experienced:**

From the results illustrated below (presented for a 6 minutes duration 64 Kbits/sec MBMS streaming video), we observe that in all instances simulated (20 MBMS users, 40 MBMS users and 70 MBMS users distributed within the cell) our proposed “Dual Transmission mode cell” approach outperforms all others in terms of capacity (i.e., downlink transmission power) efficiency and channel quality improvement (see Figure 55 - Figure 57), when a pedestrian urban environment is used. More specifically the following have been observed (see Table 21):

*Table 21 MBMS Provision – Scenario 1 Results: Capacity and Channel Quality*

		<b>UE Counting</b>	<b>Power Counting</b>	<b>FACH with Power Control</b>	<b>Rate Splitting</b>	<b>Dual transmission mode cell</b>
<b>Average Downlink Capacity Requirements</b>	<b>70 UEs present in the cell</b>	2.022 watts <i>(119.3% more)</i>	2.022 watts <i>(119.3% more)</i>	1.358 watts <i>(47.3% more)</i>	1.185 watts <i>(28.5% more)</i>	<b>0.922 watts</b>
	<b>40 UEs present in the cell</b>	2.022 watts <i>(124.2% more)</i>	1.911 watts <i>(111.9% more)</i>	1.358 watts <i>(50.5% more)</i>	1.185 watts <i>(31.4% more)</i>	<b>0.902 watts</b>
	<b>20 UEs present in the cell</b>	2.022 watts <i>(181.6% more)</i>	1.117 watts <i>(55.6% more)</i>	1.217 watts <i>(69.5% more)</i>	1.041 watts <i>(45% more)</i>	<b>0.718 watts</b>
<b>Average Channel Quality Experienced</b>	<b>70 UEs present in the cell</b>	12.37 dB <i>(2.76 dB less)</i>	12.37 dB <i>(2.76 dB less)</i>	13.91 dB <i>(1.22 dB less)</i>	14.32 dB <i>(0.81 dB less)</i>	<b>15.13 dB</b>
	<b>40 UEs present in the cell</b>	12.37 dB <i>(2.87 dB less)</i>	12.58 dB <i>(2.66 dB less)</i>	13.91 dB <i>(1.33 dB less)</i>	14.32 dB <i>(0.92 dB less)</i>	<b>15.24 dB</b>
	<b>20 UEs present in the cell</b>	12.37 dB <i>(3.59 dB less)</i>	14.53 dB <i>(1.43 dB less)</i>	14.20 dB <i>(1.76 dB less)</i>	14.75 dB <i>(1.21 dB less)</i>	<b>15.96 dB</b>

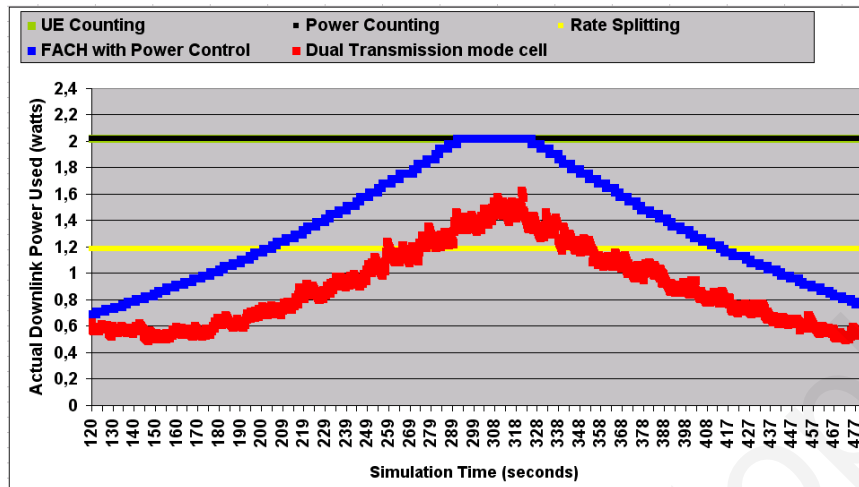

(a) Actual Downlink Power Used (watts)

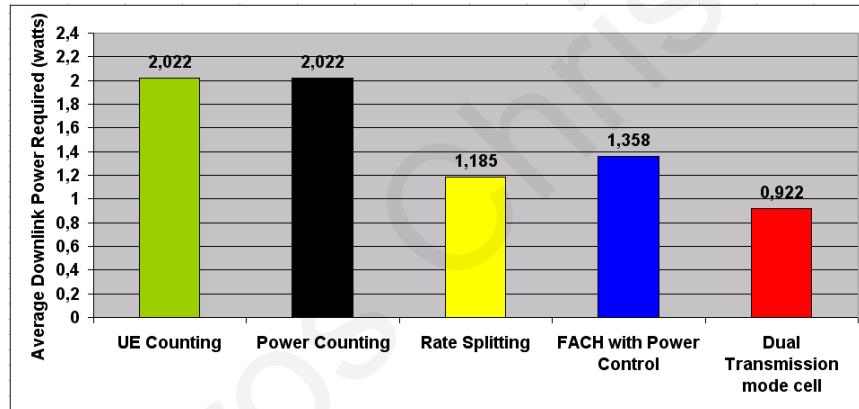

(b) Average Downlink Power Required (watts)

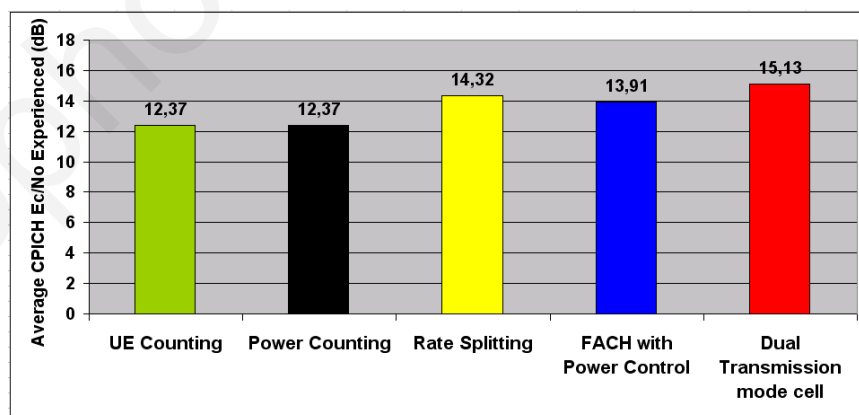

(c) Average CPICH  $E_c/N_o$  Experienced (dB)

Figure 55 MBMS Provision - Scenario 1 Results: Capacity and Channel Quality (70 UEs)

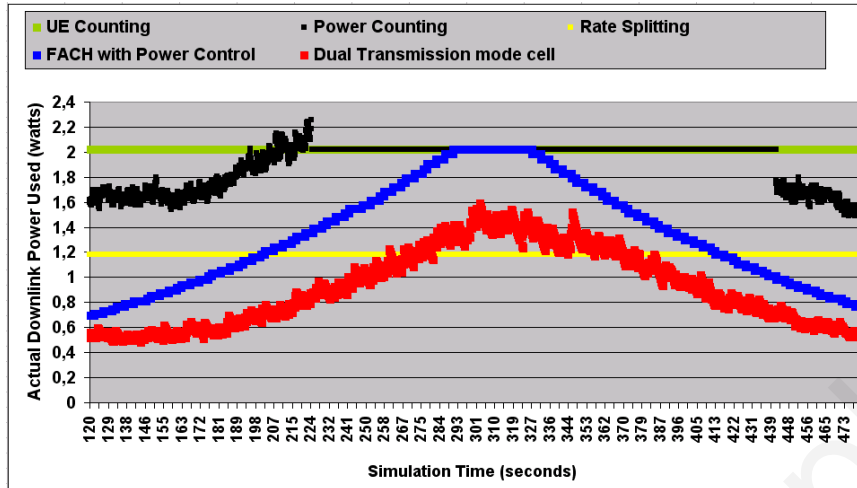

(a) Actual Downlink Power Used (watts)

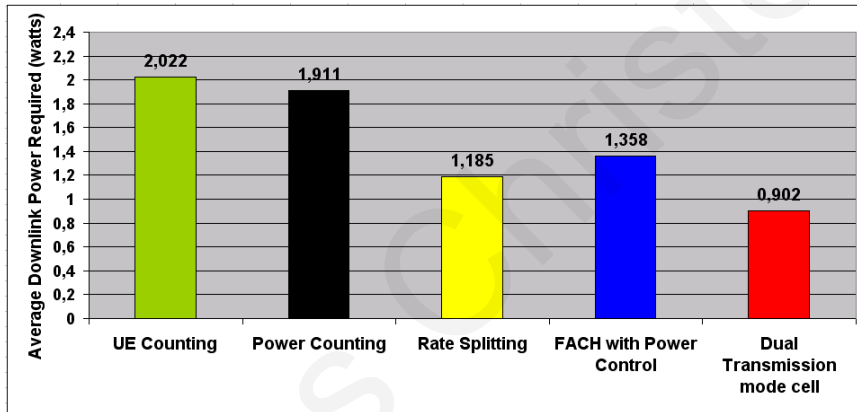

(b) Average Downlink Power Required (watts)

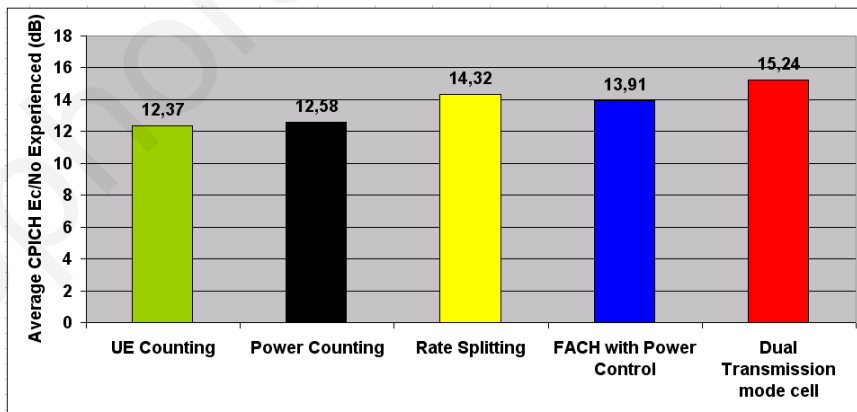

(c) Average CPICH Ec/No Experienced (dB)

Figure 56 MBMS Provision - Scenario 1 Results: Capacity and Channel Quality (40 UEs)

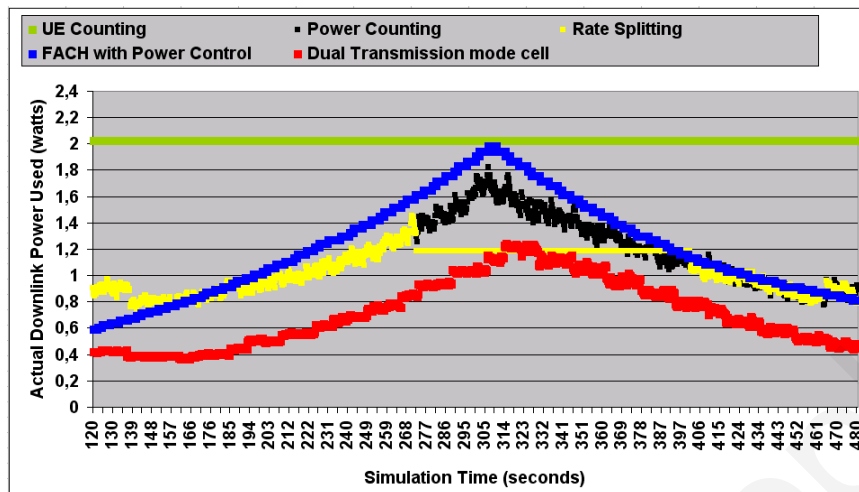

(a) Actual Downlink Power Used (watts)

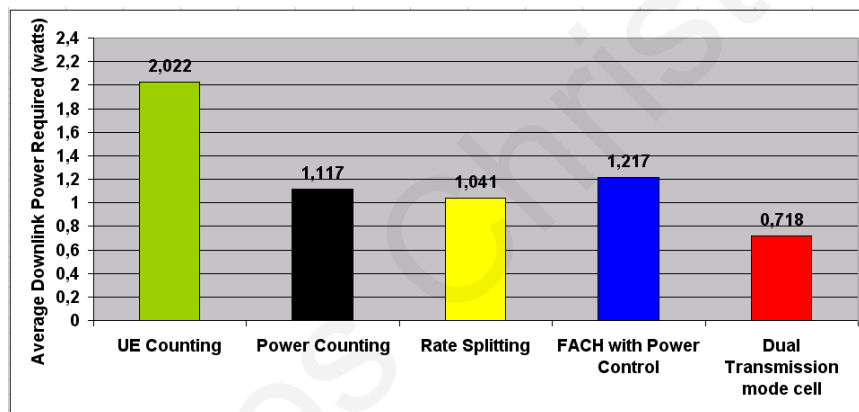

(b) Average Downlink Power Required (watts)

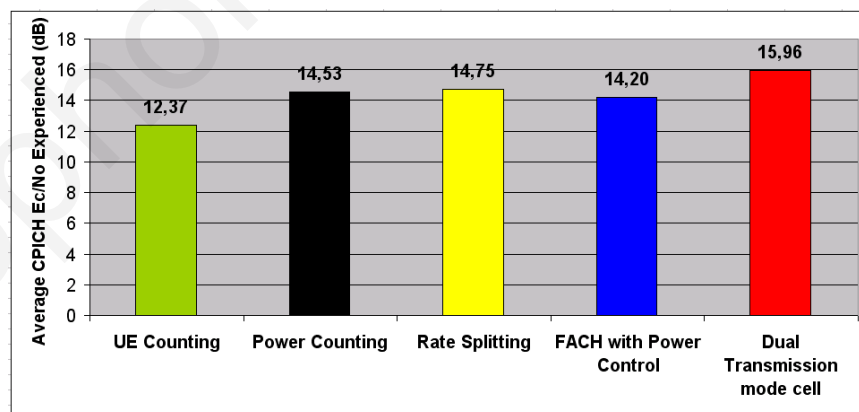

(c) Average CPICH  $E_c/N_0$  Experienced (dB)

Figure 57 MBMS Provision - Scenario 1 Results: Capacity and Channel Quality (20 UEs)

By comparing the results collected from the low and high loaded instances (see Figure 55 and Figure 57) we can observe that the average downlink power used by our proposed approach in the high loaded instance (i.e., 0.922 watts to support 70 UEs) is much less than the average downlink power required by all the other related approach in the low loaded instance (i.e., 1.041 watts for Rate Splitting and more for the other approaches to support 20 UEs). Thus, for the presented scenario, our proposed scheme manages, with much less capacity allocated, to support 50 more users (250% more UEs) than all the other related approaches.

Note that the same scenario has been simulated with higher bit rates (i.e., 256 Kbits/sec MBMS streaming video) providing exactly the same trends. However, the main difference is that much more transmission power (capacity) is allocated for the higher bit rate distribution.

**Terminal Battery Consumption, Number of Reports Required, Time Required for Context Reporting Request Process to finish and Uplink Noise Rise due to reporting:**

From the results presented above, for a pedestrian urban environment, we observe that our “Dual Transmission mode cell” approach, irrespective of the load present in the cell (low, medium or high) can provide the MBMS service, with the requested QoS, to the MBMS users with the least amount of transmission power (capacity) requirements and also achieves the best channel quality performance improvement than any of the other competing approaches.

Below, we demonstrate the additional benefits that we can have on the terminal’s battery consumption, the number of reports required, the time required for context reporting request process to finish (and thus the time required for a decision to be made) and the uplink noise rise due to reporting, when integrating our proposed context reporting request process in the “Dual Transmission mode cell” approach. Results concerning the gains that can be achieved with our proposed context reporting request process are presented for the high loaded (70 MBMS users) instance.

It is important to note here that with the UE Counting approach, the RNC always knows the number of MBMS users in the RRC connected state that are present in the cell. In our simulation environment all the MBMS users (by default) are in RRC-connected state (since OPNET modeller does not support RRC- Idle state), thus no context reporting takes place with this approach. For this reason, in the results that follow, the UE Counting approach is not included in the comparative evaluation with the other approaches.

As illustrated in Figure 58 and Table 22, by utilizing the new context reporting request process we proposed in section 4.7.2, significant gains can be achieved. By performing the context reporting request process in successive steps (i.e., zone by zone and most importantly starting from the cell's edge) and allowing the algorithm to interrupt the context reporting request process when further reporting is considered redundant, we significantly reduce the amount of context reports required to be received by the algorithm (and thus the number of the UEs that have to report) in order for a Transmission Arrangement decision to be made. As a result, this also significantly reduces the time required for the Information Collection step to be performed, reduces the processing effort and the time required by the RNC for making a decision (since less context reports are considered), and also lessens the possibility for congestion in the uplink. By reducing the need for context reporting from the UEs, significant gains have also been achieved on the terminal's battery consumption. Thus, with our proposed approach, even in situations where a large number of users are present in the cell, scalability and improved system performance is achieved.

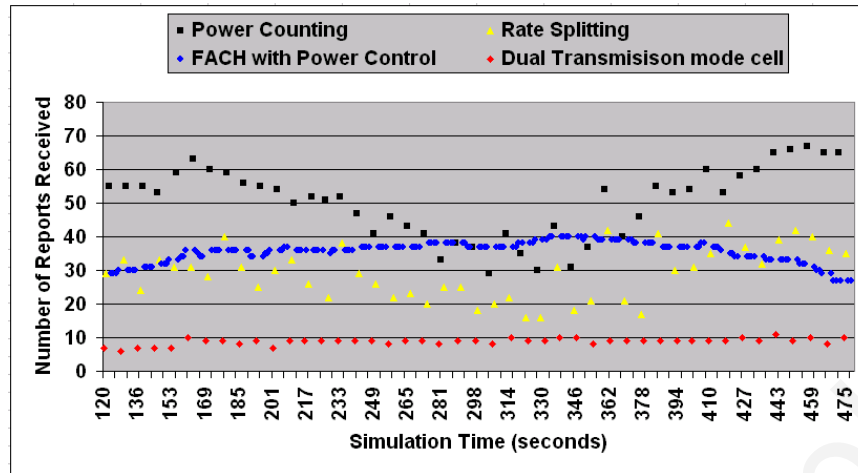

Figure 58 MBMS Provision - Scenario 1 Results: Number of context reports received (70 UEs)

Table 22 MBMS Provision - Scenario 1 Results: Context Reporting Request Process (70 UEs)

		Power Counting	FACH with Power Control	Rate Splitting	Dual transmission mode cell
<b>High Loaded Instance (70 MBMS users present in the cell)</b>	Average number of UEs required to report	50	36	29	9
	Average amount of time required for Context Reporting to finish	90.466 ms	75.569 ms	59.866ms	33.888 ms
	Aggregated Battery consumption by all the Terminals	3.490 watts	16.861 watts	1.942 watts	1.423 watts
	Average Terminal Battery Consumption	0.051 watts 1.27% of the battery life	0.248 watts 6.2% of the battery life	0.028 watts 0.7% of the battery life	0.021 watts 0.52% of the battery life

As observed above, our proposed “Dual Transmission mode cell” approach, by utilizing the new context reporting request process, outperforms all other related approaches in terms of terminal battery consumption and time required for context reporting request process to finish, since it significantly reduces the amount of reports required to be received and thus the amount of time required for a Transmission Arrangement decision to be made. Based on the results presented in Table 22, if we assume a 3.6 Volt Li-Ion 1100 mAh cell phone battery, a consumption of about 4 watts gets the battery fully discharged (Watts = Volt x Ampere). Thus, for a 6 minute duration video clip, the “Power Counting” consumes 1.27% of the



terminal's battery life, the "FACH with Power Control" 6.2%, the "Rate Splitting" 0.7% while our proposed "Dual Transmission mode cell" 0.52%.

Moreover, by reducing the need for frequent context reporting from the UEs, significant gains have also been achieved on the uplink interference caused due to the context reporting. Results concerning the uplink interference introduced by each approach, are presented and compared in Figure 59 and Figure 60. As illustrated in Figure 59, our proposed approach manages to outperform all the other related approaches in terms of uplink interference caused, and keeps the interference introduced during the MBMS session to less than 2 femtowatts (1 femtowatt =  $10^{-15}$  watt). Moreover, as illustrated in Figure 60, the aggregated uplink interference caused during the session, when our proposed approach is applied, is only 342 femtowatts. On the other hand, when the Rate Splitting is applied it is 6,429 femtowatts, when the Power Counting is applied it is 19,173 and when the FACH with Power Control is applied it is 34,846 femtowatts.

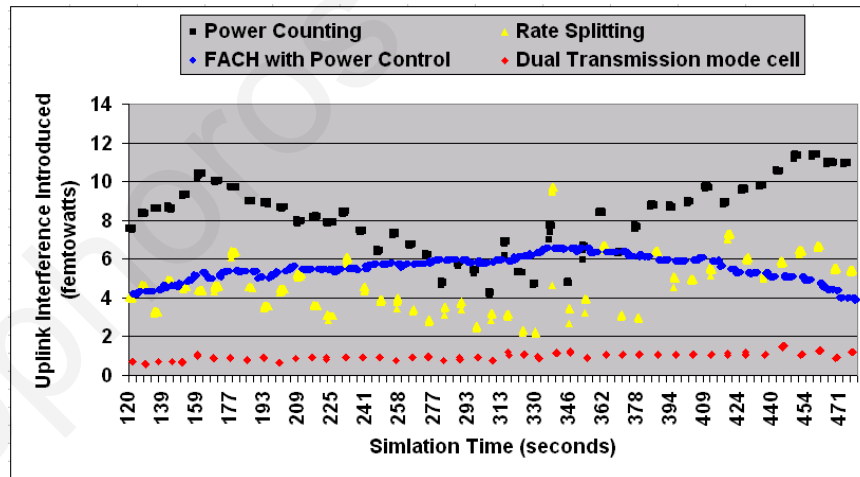

Figure 59 MBMS Provision - Scenario 1 Results: Actual Uplink Interference (70 UEs)

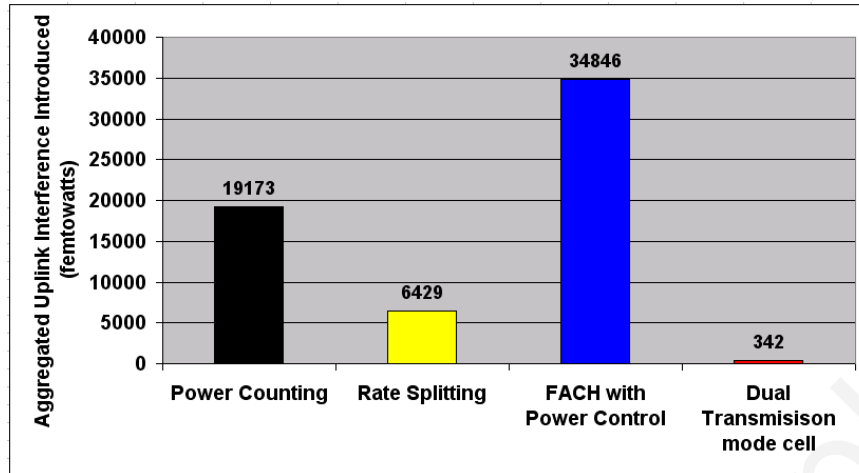

Figure 60 MBMS Provision - Scenario 1 Results: Aggregated Uplink Interference (70 UEs)

The results presented above are also summarized and compared in Table 23. Given the benefits achieved by our proposed “Dual Transmission mode cell” approach, we can conclude that our approach significantly outperforms the other competing approaches when a pedestrian urban environment is used.

Table 23 MBMS Provision – Scenario 1: Summary of Results presented

		UE Counting	Power Counting	FACH with Power Control	Rate Splitting	Dual transmission mode cell
Average Downlink Capacity Requirements	70 UEs present in the cell	2.022 watts <i>(119.3% more)</i>	2.022 watts <i>(119.3% more)</i>	1.358 watts <i>(47.3% more)</i>	1.185 watts <i>(28.5% more)</i>	<b>0.922 watts</b>
	40 UEs present in the cell	2.022 watts <i>(124.2% more)</i>	1.911 watts <i>(111.9% more)</i>	1.358 watts <i>(50.5% more)</i>	1.185 watts <i>(31.4% more)</i>	<b>0.902 watts</b>
	20 UEs present in the cell	2.022 watts <i>(181.6% more)</i>	1.117 watts <i>(55.6% more)</i>	1.217 watts <i>(69.5% more)</i>	1.041 watts <i>(45% more)</i>	<b>0.718 watts</b>
Average Channel Quality Experienced	70 UEs present in the cell	12.37 dB <i>(2.76 dB less)</i>	12.37 dB <i>(2.76 dB less)</i>	13.91 dB <i>(1.22 dB less)</i>	14.32 dB <i>(0.81 dB less)</i>	<b>15.13 dB</b>
	40 UEs present in the cell	12.37 dB <i>(2.87 dB less)</i>	12.58 dB <i>(2.66 dB less)</i>	13.91 dB <i>(1.33 dB less)</i>	14.32 dB <i>(0.92 dB less)</i>	<b>15.24 dB</b>
	20 UEs present in the cell	12.37 dB <i>(3.59 dB less)</i>	14.53 dB <i>(1.43 dB less)</i>	14.20 dB <i>(1.76 dB less)</i>	14.75 dB <i>(1.21 dB less)</i>	<b>15.96 dB</b>
QoS supported for all users		Yes	Yes	Yes	No	Yes
Context Reporting Request Process (70 UEs present in the cell)	Average number of UEs required to report		50	36	29	<b>9</b>
	Average amount of time required for Context Reporting to finish		90.466 ms	75.569 ms	59.866ms	<b>33.888 ms</b>
	Aggregated Battery consumption by all the Terminals		3.490 watts	16.861 watts	1.942 watts	<b>1.423 watts</b>
	Average Terminal Battery consumption		0.051 watts <i>(1.27% of battery life)</i>	0.248 watts <i>(6.2% of battery life)</i>	0.028 watts <i>(0.7% of battery life)</i>	<b>0.021 watts (0.52% of battery life)</b>
	Aggregated Uplink Noise rise (femtowatts)		19173 femtowatts	34846 femtowatts	6429 femtowatts	<b>342 femtowatts</b>

#### 4.8.2.2 Scenario 2: Low vehicular urban environment

The results collected from Scenario 2, relate to the tradeoffs and the gains achieved by each approach in a low vehicular urban environment. Similarly to scenario 1, the results collected compare the capacity requirements, the channel quality experienced, the terminal's battery consumption (due to reporting), the total number of UEs that are required to report, the

time required for the context reporting request process to finish (and thus the time required for the final decision to be made) and the uplink interference caused, by each approach.

**Capacity (Downlink power) requirements and Channel Quality experienced:**

From the results illustrated below (presented for a 3 minutes duration 64 Kbits/sec MBMS streaming video), we observe that in all instances simulated (20 MBMS users, 40 MBMS users and 70 MBMS users distributed within the cell) our proposed “Dual Transmission mode cell” approach outperforms all others in terms of capacity (i.e., downlink transmission power) efficiency and channel quality improvement (see Figure 61 - Figure 63), when a low vehicular urban environment is used. More specifically the following have been observed (see Table 24):

*Table 24 MBMS Provision – Scenario 2 Results: Capacity and Channel Quality*

		<b>UE Counting</b>	<b>Power Counting</b>	<b>FACH with Power Control</b>	<b>Rate Splitting</b>	<b>Dual transmission mode cell</b>
<b>Average Downlink Capacity Requirements</b>	<b>70 UEs present in the cell</b>	2.022 watts <i>(91.8% more)</i>	2.022 watts <i>(91.8% more)</i>	1.319 watts <i>(25.14% more)</i>	1.185 watts <i>(12.4% more)</i>	<b>1.054 watts</b>
	<b>40 UEs present in the cell</b>	2.022 watts <i>(155.3% more)</i>	1.907 watts <i>(140.8% more)</i>	0.967 watts <i>(22.1% more)</i>	1.185 watts <i>(49.6% more)</i>	<b>0.792 watts</b>
	<b>20 UEs present in the cell</b>	2.022 watts <i>(172.5% more)</i>	1.213 watts <i>(63.48% more)</i>	0.996 watts <i>(34.23% more)</i>	1.042 watts <i>(40.43% more)</i>	<b>0.742 watts</b>
<b>Average Channel Quality Experienced</b>	<b>70 UEs present in the cell</b>	11.71 dB <i>(2.29 dB less)</i>	11.71 dB <i>(2.29 dB less)</i>	13.31 dB <i>(0.69 dB less)</i>	13.44 dB <i>(0.56 dB less)</i>	<b>14.00 dB</b>
	<b>40 UEs present in the cell</b>	11.71 dB <i>(2.93 dB less)</i>	11.97 dB <i>(2.67 dB less)</i>	13.91 dB <i>(0.73 dB less)</i>	13.44 dB <i>(1.2 dB less)</i>	<b>14.64 dB</b>
	<b>20 UEs present in the cell</b>	11.71 dB <i>(3.02 dB less)</i>	13.17 dB <i>(1.56 dB less)</i>	13.75 dB <i>(0.98 dB less)</i>	13.62 dB <i>(1.11 dB less)</i>	<b>14.73 dB</b>

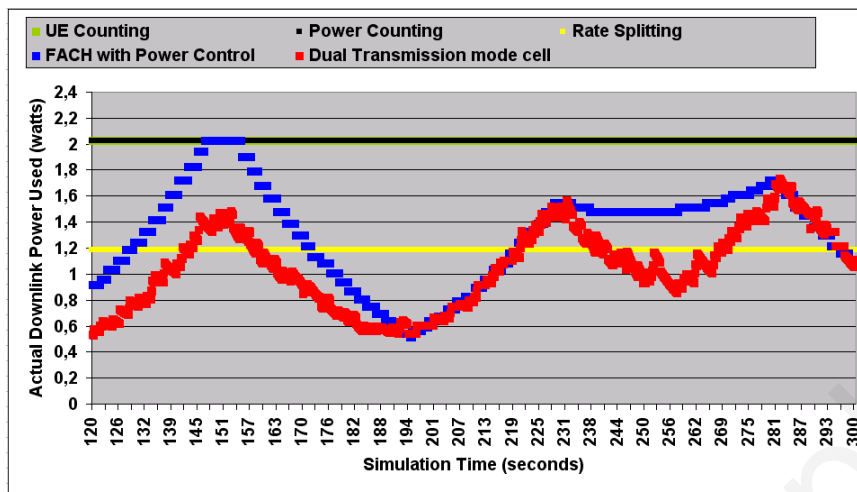

(a) Actual Downlink Power Used (watts)

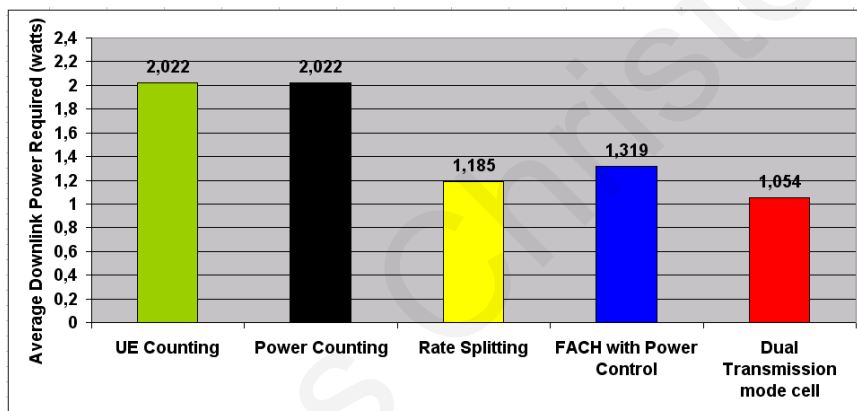

(b) Average Downlink Power Required (watts)

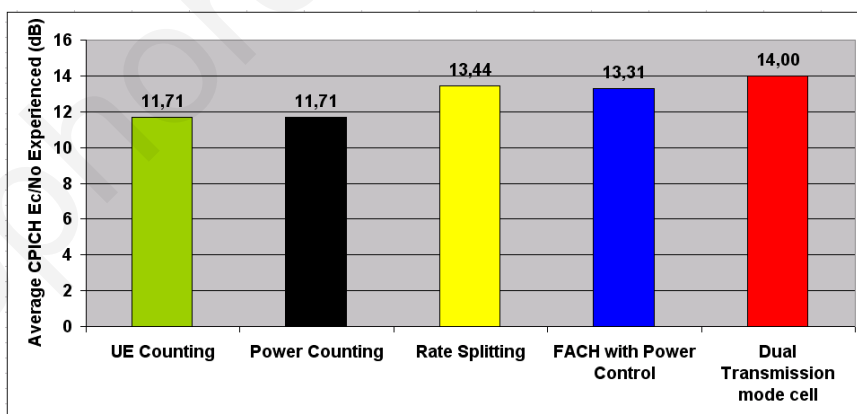

(c) Average CPICH  $E_c/N_0$  Experienced (dB)

Figure 61 MBMS Provision - Scenario 2 Results: Capacity and Channel Quality (70 UEs)

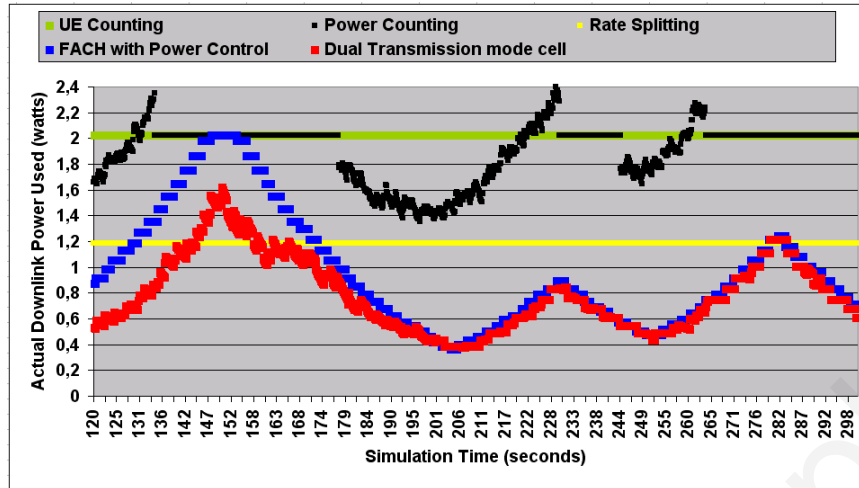

(a) Actual Downlink Power Used (watts)

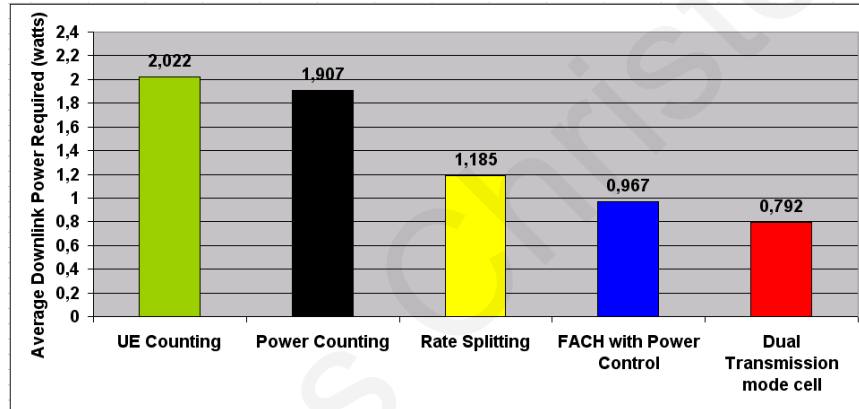

(b) Average Downlink Power Required (watts)

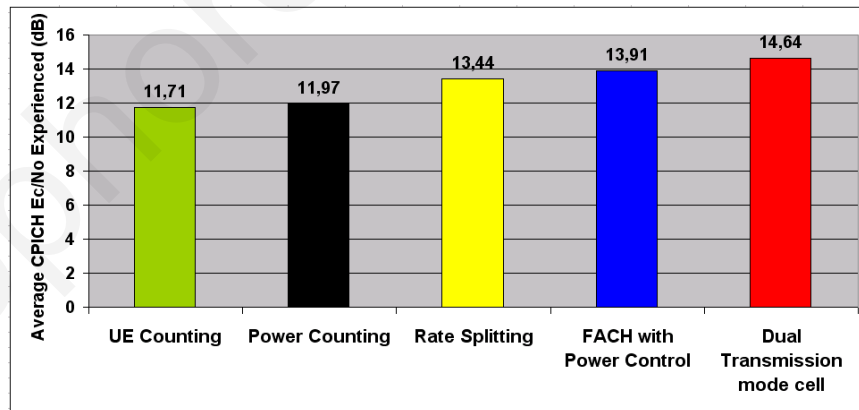

(c) Average CPICH Ec/No Experienced (dB)

Figure 62 MBMS Provision - Scenario 2 Results: Capacity and Channel Quality (40 UEs)

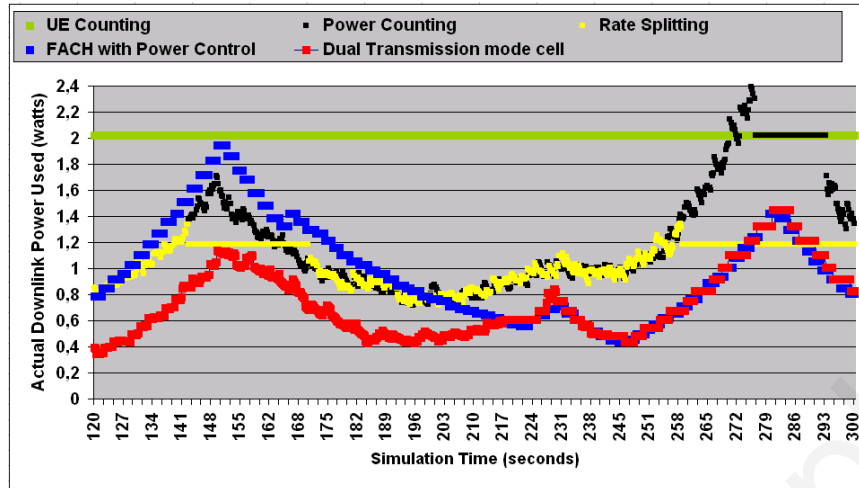

(a) Actual Downlink Power Used (watts)

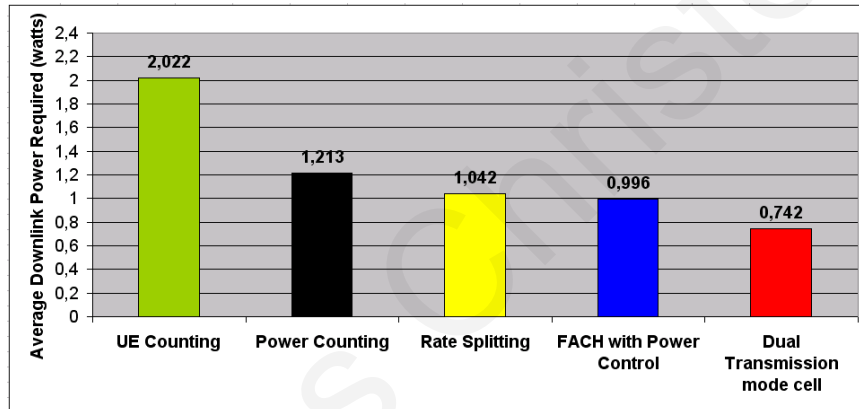

(b) Average Downlink Power Required (watts)

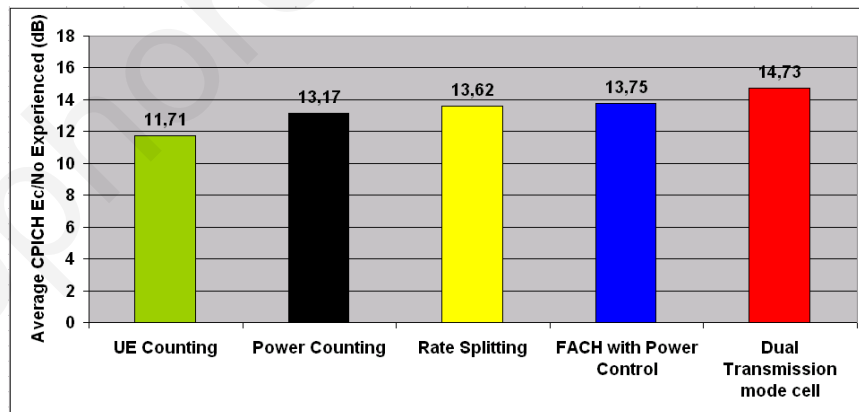

(c) Average CPICH  $E_c/N_0$  Experienced (dB)

Figure 63 MBMS Provision - Scenario 2 Results: Capacity and Channel Quality (20 UEs)

Note that the same scenario has also been simulated with higher bit rates (i.e. 256 Kbits/sec MBMS streaming video) providing exactly the same trends. However, the main

difference is that much more transmission power (capacity) is allocated for the higher bit rate distribution.

**Terminal Battery Consumption, Number of Reports Required, Time Required for Context Reporting Request Process to finish and Uplink Noise Rise due to reporting:**

From the results presented above for a low vehicular urban environment, we observe that our “Dual Transmission mode cell” approach, irrespective of the load present in the cell (low, medium or high) can provide the MBMS service, with the requested QoS, to the MBMS users with the least amount of transmission power (capacity) requirements and also achieves the best channel quality performance improvement than any of the other competing approaches.

Below we demonstrate the additional benefits that we can have on the terminal’s battery consumption, the number of reports required, the time required for context reporting request process to finish (and thus the time required for a decision to be made) and the uplink noise rise due to reporting, when integrating our proposed context reporting request process in the “Dual Transmission mode cell” approach. Results concerning the gains that can be achieved with our proposed context reporting request process are presented for the high loaded (70 MBMS users) instance. As illustrated in Figure 64 and Table 25, by utilizing the new context reporting request process we proposed in section 4.7.2, significant gains can be achieved.

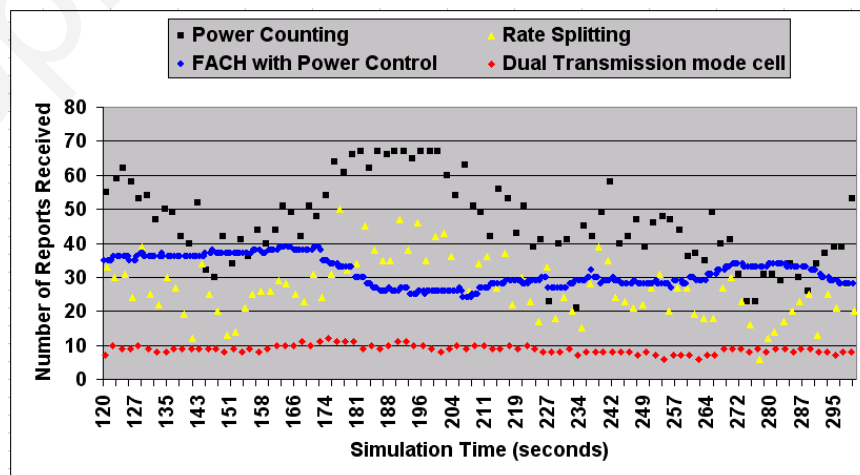

Figure 64 MBMS Provision - Scenario 2 Results: Number of context reports received (70 UEs)



Table 25 MBMS Provision - Scenario 2 Results: Context Reporting Request Process (70 UEs)

		Power Counting	FACH with Power Control	Rate Splitting	Dual transmission mode cell
<b>High Loaded Instance</b> (70 MBMS users present in the cell)	Average number of UEs required to report	46	31	26	<b>9</b>
	Average amount of time required for Context Reporting to finish	86.659 ms	62.594 ms	54.105 ms	<b>33.868 ms</b>
	Aggregated Battery consumption by all the Terminals	6.031 watts	28.351 watts	3.489 watts	<b>2.782 watts</b>
	Average Terminal Battery Consumption	0.089 watts 2.23% of the battery life	0.417 watts 10.43% of the battery life	0.051 watts 1.28% of the battery life	<b>0.041watts</b> <b>1.02% of the battery life</b>

As observed above, our proposed “Dual Transmission mode cell” approach, by utilizing the new context reporting request process, outperforms all other related approaches in terms of terminal battery consumption and time required for context reporting request process to finish since it significantly reduces the amount of reports required to be received and thus the amount of time required for a Transmission Arrangement decision to be made. Based on the results presented in Table 25, again if we assume a 3.6 Volt Li-Ion 1100 mAh cell phone battery, a consumption of about 4 watts gets the battery fully discharged (Watts = Volt x Ampere). Thus, for a 3 minute duration video clip, the “Power Counting” consumes 2.23% of the terminal’s battery life, the “FACH with Power Control” 10.43%, the “Rate Splitting” 1.28% while our proposed “Dual Transmission mode cell” 1.02%.

Moreover, by reducing the need for frequent context reporting from the UEs, significant gains have also been achieved on the uplink interference caused due to the context reporting. Results concerning the uplink interference introduced by each approach, due to this reporting requirement, are presented and compared in Figure 65 and Figure 66. As illustrated in Figure 65, our proposed approach manages to outperform all the other related approaches in terms of uplink interference caused and keep the interference introduced during the MBMS session in

less than 2 femtowatts (1 femtowatt =  $10^{-15}$  watt). Moreover, as illustrated in Figure 66, the aggregated uplink interference caused during the session, when our proposed approach is applied, is only 694 femtowatts. On the other hand, when the Rate Splitting is applied it is 11,560 femtowatts, when the Power Counting is applied it is 33,035 femtowatts and when the FACH with Power Control is applied it is 50,390 femtowatts.

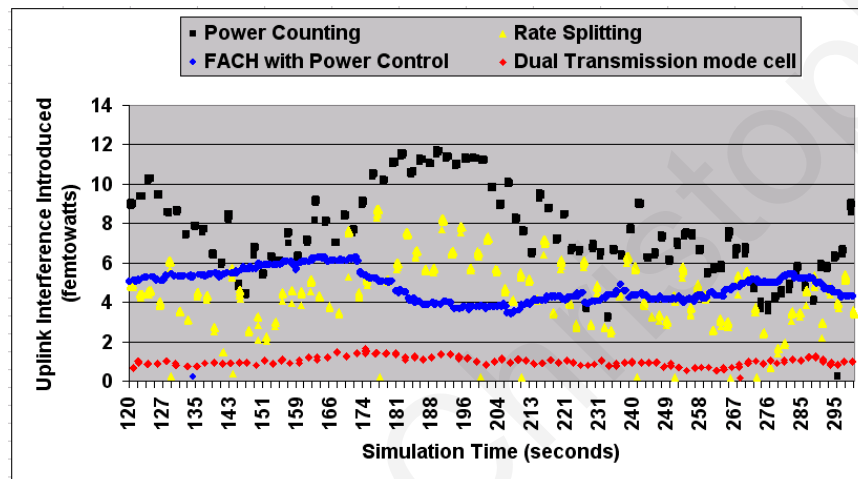

Figure 65 MBMS Provision - Scenario 2 Results: Actual Uplink Interference (70 UEs)

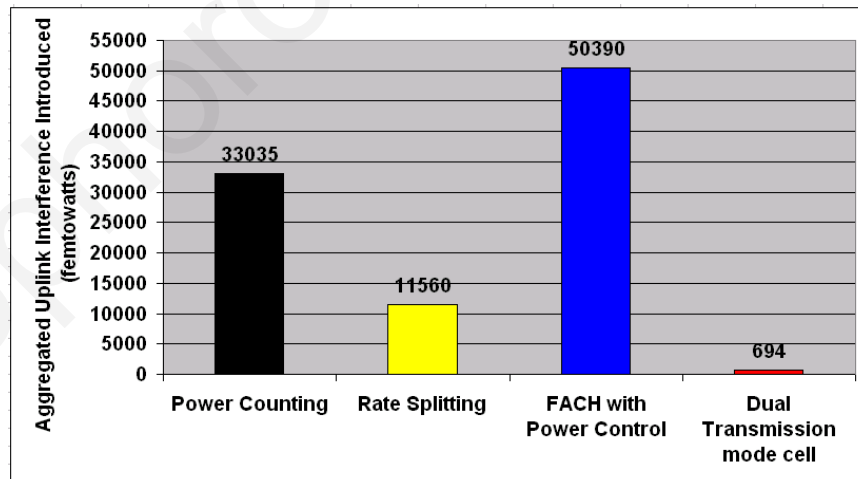

Figure 66 MBMS Provision - Scenario 2 Results: Aggregated Uplink (70 UEs)

The results presented above are also summarized and compared in Table 26. Given the benefits achieved by our proposed “Dual Transmission mode cell” approach, we can conclude

that our approach significantly outperforms the other competing approaches also when a low vehicular urban environment is used.

Table 26 MBMS Provision – Scenario 2: Summary of Results presented

		UE Counting	Power Counting	FACH with Power Control	Rate Splitting	Dual transmission mode cell
Average Downlink Capacity Requirements	70 UEs present in the cell	2.022 watts <i>(91.8% more)</i>	2.022 watts <i>(91.8% more)</i>	1.319 watts <i>(25.14% more)</i>	1.185 watts <i>(12.4% more)</i>	<b>1.054 watts</b>
	40 UEs present in the cell	2.022 watts <i>(155.3% more)</i>	1.907 watts <i>(140.8% more)</i>	0.967 watts <i>(22.1% more)</i>	1.185 watts <i>(49.6% more)</i>	<b>0.792 watts</b>
	20 UEs present in the cell	2.022 watts <i>(172.5% more)</i>	1.213 watts <i>(63.48% more)</i>	0.996 watts <i>(34.23% more)</i>	1.042 watts <i>(40.43% more)</i>	<b>0.742 watts</b>
Average Channel Quality Experienced	70 UEs present in the cell	11.71 dB <i>(2.29 dB less)</i>	11.71 dB <i>(2.29 dB less)</i>	13.31 dB <i>(0.69 dB less)</i>	13.44 dB <i>(0.56 dB less)</i>	<b>14.00 dB</b>
	40 UEs present in the cell	11.71 dB <i>(2.93 dB less)</i>	11.97 dB <i>(2.67 dB less)</i>	13.91 dB <i>(0.73 dB less)</i>	13.44 dB <i>(1.2 dB less)</i>	<b>14.64 dB</b>
	20 UEs present in the cell	11.71 dB <i>(3.02 dB less)</i>	13.17 dB <i>(1.56 dB less)</i>	13.75 dB <i>(0.98 dB less)</i>	13.62 dB <i>(1.11 dB less)</i>	<b>14.73 dB</b>
<b>QoS supported for all users</b>		Yes	Yes	Yes	No	<b>Yes</b>
Context Reporting Request Process (70 UEs present in the cell)	Average number of UEs required to report		46	31	26	<b>9</b>
	Average amount of time required for Context Reporting to finish		86.659 ms	62.594 ms	54.105 ms	<b>33.868 ms</b>
	Aggregated Battery consumption by all the Terminals		6.031 watts	28.351 watts	3.489 watts	<b>2.782 watts</b>
	Average Terminal Battery consumption		0.089 watts <i>(2.23% of battery life)</i>	0.417 watts <i>(10.43% of battery life)</i>	0.051 watts <i>(1.28% of battery life)</i>	<b>0.041watts (1.02% of battery life)</b>
	Aggregated Uplink Noise rise (femtowatts)		33035 femtowatts	50390 femtowatts	11560 femtowatts	<b>694 femtowatts</b>

#### 4.8.2.3 Scenario 3: High vehicular urban environment

The results collected from Scenario 3, relate to the tradeoffs and the gains achieved by each approach in a high vehicular urban environment. Similarly to scenario 2 and 3, the results collected compare the capacity requirements, the channel quality experienced, the

terminal's battery consumption (due to reporting), the total number of UEs that are required to report, the time required for the context reporting request process to finish (and thus the time required for the final decision to be made) and the uplink interference caused, by each approach.

**Capacity (Downlink power) requirements and Channel Quality experienced:**

From the results illustrated below (presented for a 2 minutes duration 64 Kbits/sec MBMS streaming video), we observe that in all instances simulated (20 MBMS users, 40 MBMS users and 70 MBMS users distributed within the cell) our proposed “Dual Transmission mode cell” approach outperforms all others in terms of capacity (i.e., downlink transmission power) efficiency and channel quality improvement (see Figure 67 - Figure 69), when a vehicular urban environment is used. More specifically the following have been observed (see Table 27).

*Table 27 MBMS Provision – Scenario 3 Results: Capacity and Channel Quality*

		<b>UE Counting</b>	<b>Power Counting</b>	<b>FACH with Power Control</b>	<b>Rate Splitting</b>	<b>Dual transmission mode cell</b>
<b>Average Downlink Capacity Requirements</b>	<b>70 UEs present in the cell</b>	2.022 watts <i>(91.3% more)</i>	2.022 watts <i>(91.3% more)</i>	1.234 watts <i>(16.7% more)</i>	1.185 watts <i>(12.1% more)</i>	<b>1.057 watts</b>
	<b>40 UEs present in the cell</b>	2.022 watts <i>(141% more)</i>	1.869 watts <i>(122.76% more)</i>	0.963 watts <i>(14.78% more)</i>	1.185 watts <i>(41.23% more)</i>	<b>0.839 watts</b>
	<b>20 UEs present in the cell</b>	2.022 watts <i>(156.92% more)</i>	1.225 watts <i>(55.65% more)</i>	0.970 watts <i>(23.25% more)</i>	1.041 watts <i>(32.27% more)</i>	<b>0.787 watts</b>
<hr/>						
<b>Average Channel Quality Experienced</b>	<b>70 UEs present in the cell</b>	11.15 dB <i>(2.23 dB less)</i>	11.15 dB <i>(2.23 dB less)</i>	12.74 dB <i>(0.64 dB less)</i>	12.91 dB <i>(0.47 dB less)</i>	<b>13.38 dB</b>
	<b>40 UEs present in the cell</b>	11.15 dB <i>(2.77 dB less)</i>	11.29 dB <i>(2.63 dB less)</i>	13.31 dB <i>(0.61 dB less)</i>	12.91 dB <i>(1.01 dB less)</i>	<b>13.75 dB</b>
	<b>20 UEs present in the cell</b>	11.15 dB <i>(2.96 dB less)</i>	12.68 dB <i>(1.43 dB less)</i>	13.32 dB <i>(0.79 dB less)</i>	13.23 dB <i>(0.98 dB less)</i>	<b>13.79 dB</b>

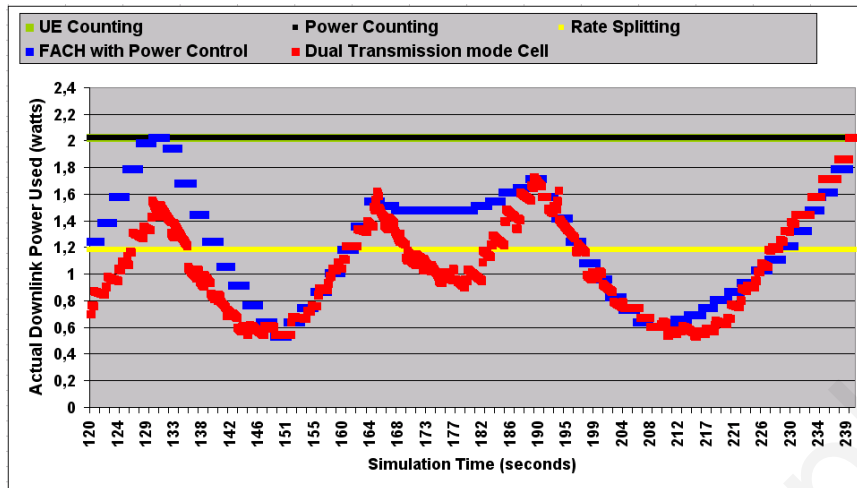

(a) Actual Downlink Power Used (watts)

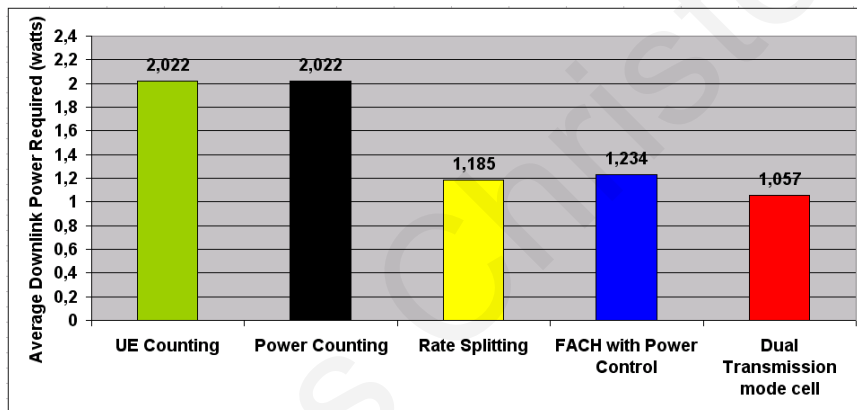

(b) Average Downlink Power Required (watts)

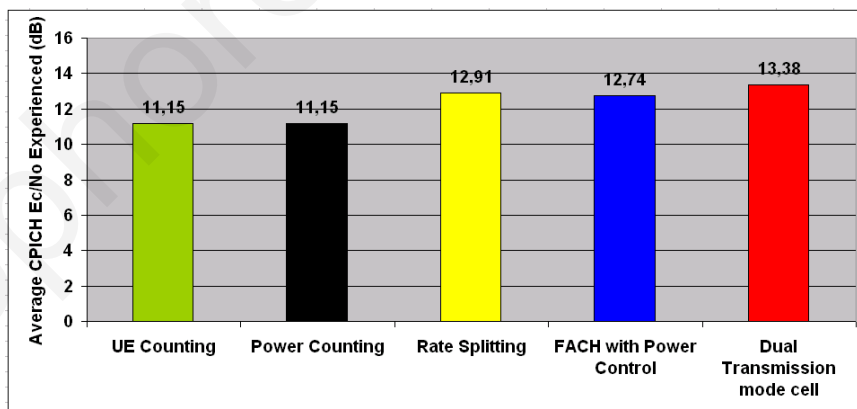

(c) Average CPICH Ec/No Experienced (dB)

Figure 67 MBMS Provision - Scenario 3 Results: Capacity and Channel Quality (70 UEs)

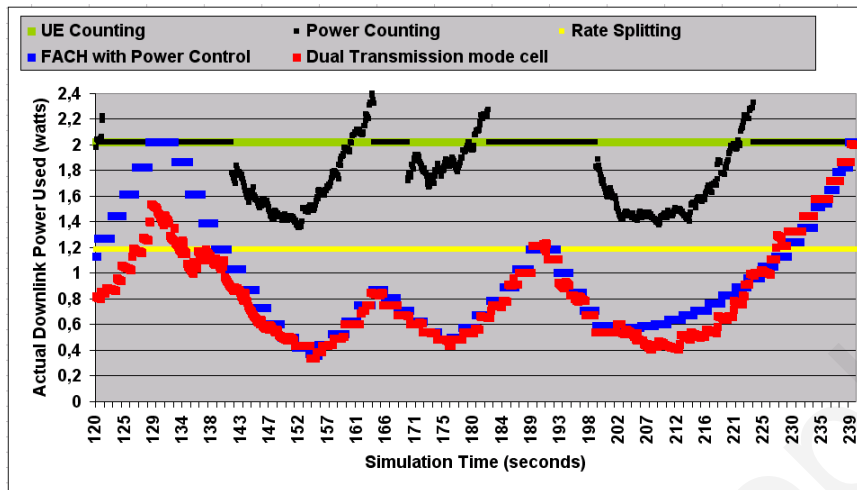

(a) Actual Downlink Power Used (watts)

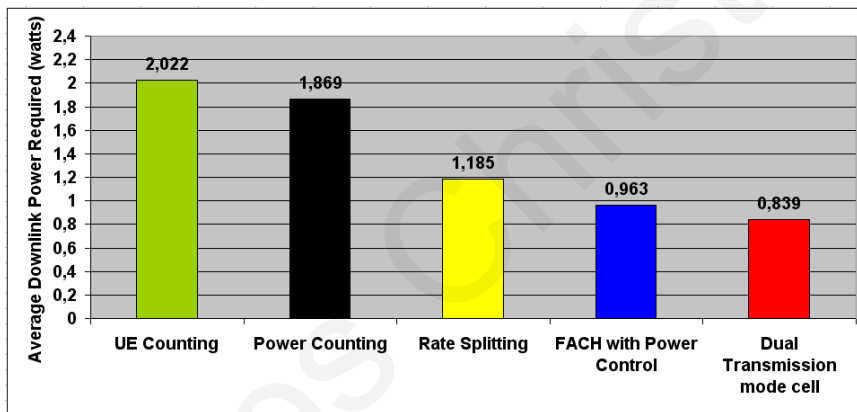

(b) Average Downlink Power Required (watts)

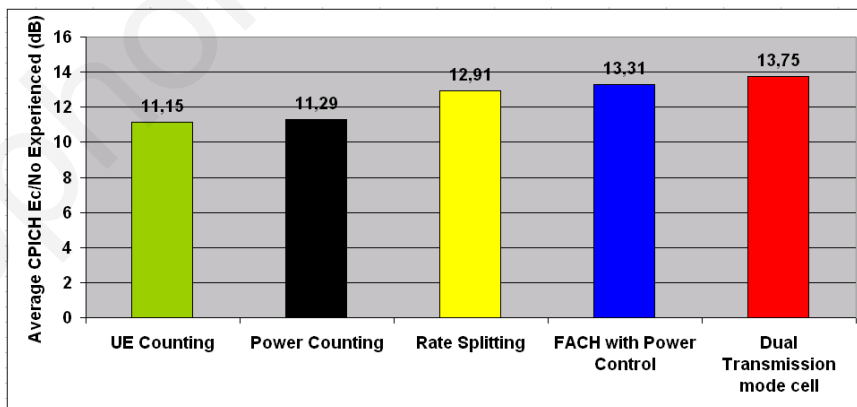

(c) Average CPICH Ec/No Experienced (dB)

Figure 68 MBMS Provision - Scenario 3 Results: Capacity and Channel Quality (40 UEs)

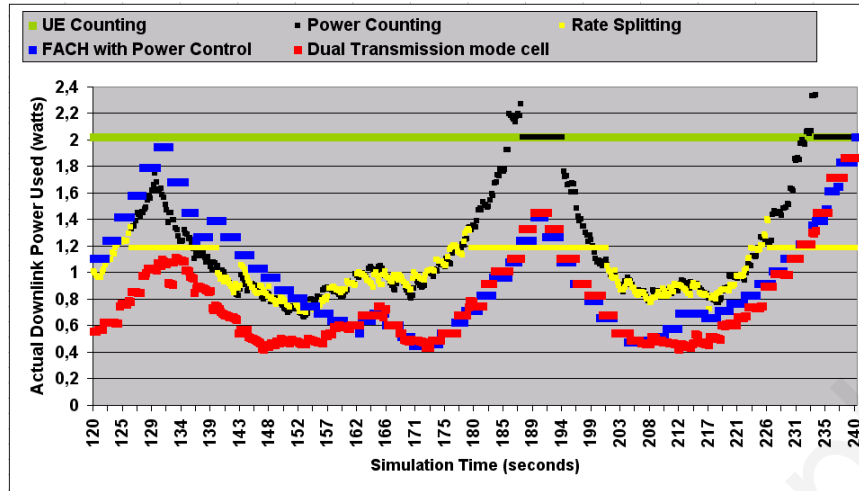

(a) Actual Downlink Power Used (watts)

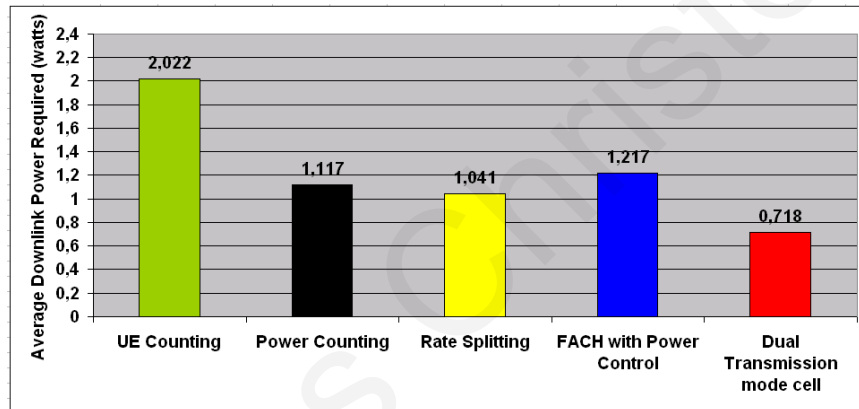

(b) Average Downlink Power Required (watts)

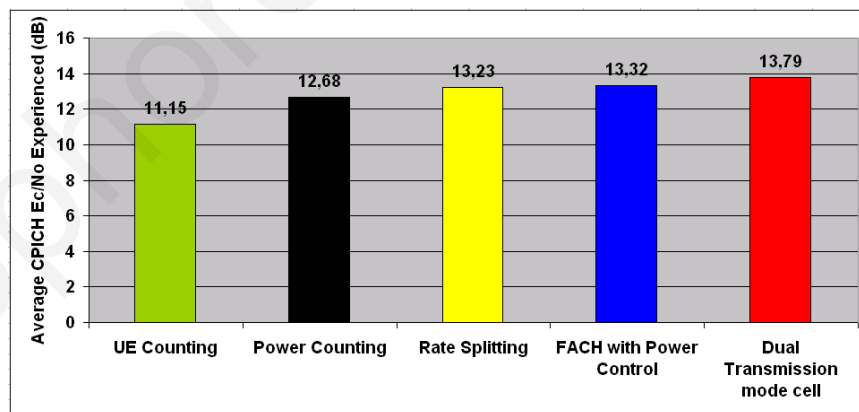

(c) Average CPICH Ec/No Experienced (dB)

Figure 69 MBMS Provision - Scenario 3 Results: Capacity and Channel Quality (20 UEs)

Note that the same scenario has been simulated with higher bit rates (i.e. 256 Kbits/sec MBMS streaming video) providing exactly the same trends. However, the main difference is that much more transmission power (capacity) is allocated for the higher bit rate distribution.

**Terminal Battery Consumption, Number of Reports Required, Time Required for Context Reporting Request Process to finish and Uplink Noise Rise due to reporting:**

From the results presented above for a vehicular urban environment, we observe that our “Dual Transmission mode cell” approach, irrespective of the load present in the cell (low, medium or high) can provide the MBMS service, with the requested QoS, to the MBMS users with the least amount of transmission power (capacity) requirements and also achieves the best channel quality performance improvement than any of the other competing approaches.

Below we demonstrate the additional benefits that we can have on the terminal’s battery consumption, the number of reports required, the time required for context reporting request process to finish (and thus the time required for a decision to be made) and the uplink noise rise due to reporting, when integrating our proposed context reporting request process in the “Dual Transmission mode cell” approach. Results concerning the gains that can be achieved with our proposed context reporting request process are presented for the high loaded (70 MBMS users) instance. As illustrated in Figure 70 and Table 28, by utilizing, the new context reporting request process we proposed in section 4.7.2, significant gains can be achieved.



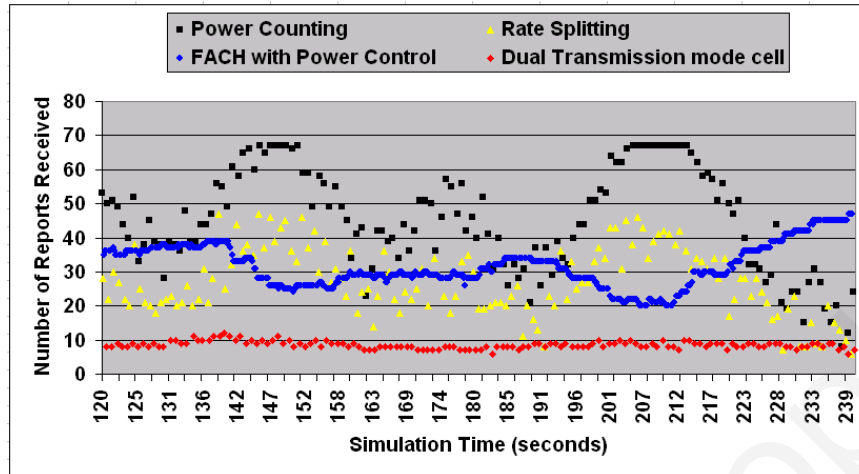

Figure 70 MBMS Provision - Scenario 3 Results: Number of context reports received (70 UEs)

Table 28 MBMS Provision - Scenario 3 Results: Context Reporting Request Process (70 UEs)

		Power Counting	FACH with Power Control	Rate Splitting	Dual transmission mode cell
<b>High Loaded Instance</b> (70 MBMS users present in the cell)	Average number of UEs required to report	45	31	27	<b>8</b>
	Average amount of time required for Context Reporting to finish	84.215 ms	61.936 ms	56.054 ms	<b>33.773 ms</b>
	Aggregated Battery consumption by all the Terminals	9.858 watts	48.577 watts	5.662 watts	<b>5.209 watts</b>
	Average Terminal Battery Consumption	0.145 watts 3.63% of the battery life	0.714 watts 17.85% of the battery life	0.083 watts 2.07% of the battery life	<b>0.076 watts</b> <b>1.09% of the battery life</b>

As observed above, our proposed “Dual Transmission mode cell” approach, by utilizing the new context reporting request process, outperforms all other related approaches in terms of terminal battery consumption and time required for context reporting request process to finish, since it significantly reduces the amount of reports required to be received and thus the amount of time required for a Transmission Arrangement decision to be made. Based on the results presented in Table 28, again if we assume a 3.6 Volt Li-Ion 1100 mAh cell phone

battery, a consumption of about 4 watts gets the battery fully discharged (Watts = Volt x Ampere). Thus, for a 2 minute duration video clip, the “Power Counting” consumes 3.63% of the terminal’s battery life, the “FACH with Power Control” 17.85%, the “Rate Splitting” 2.07% while our proposed “Dual Transmission mode cell” 1.9%.

Moreover, by reducing the need for frequent context reporting from the UEs, significant gains have also been achieved on the uplink interference caused due to the context reporting. Results concerning the uplink interference introduced by each approach are presented and compared in Figure 71 and Figure 72. As illustrated in Figure 71 our proposed approach manages to outperform all the other related approach in terms of uplink interference caused and keep the interference introduced during the MBMS session in less than 2 femtowatts (1 femtowatt =  $10^{-15}$  watt). Moreover, as illustrated in Figure 72, the aggregated uplink interference during the session, when our proposed approach is applied, it is only 1058 femtowatts. On the other hand, when the Rate Splitting is applied it is 19,500 femtowatts, when the Power Counting is applied it is 53,226 femtowatts and when the FACH with Power Control is applied it is 77,319 femtowatts.

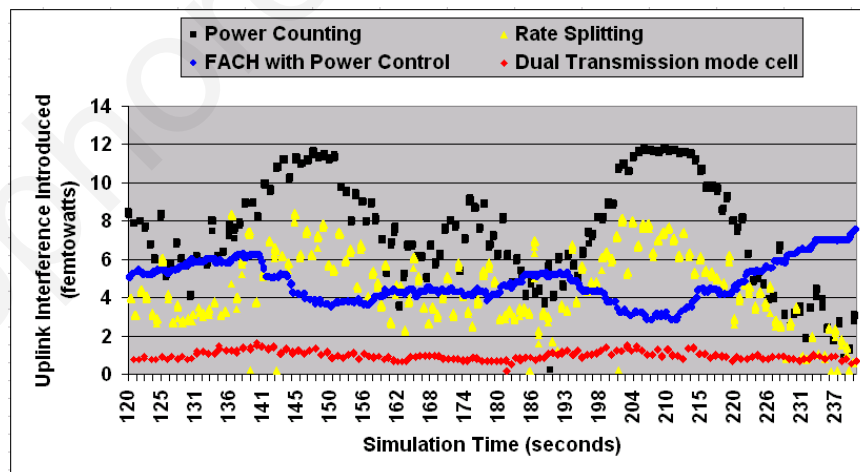

Figure 71 MBMS Provision - Scenario 3 Results: Actual Uplink Interference (70 UEs)

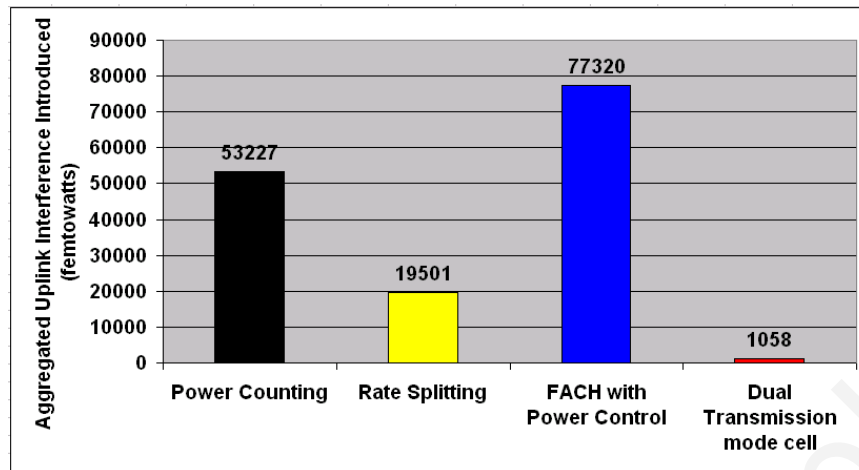

Figure 72 MBMS Provision - Scenario 3 Results: Aggregated Uplink Interference (70 UEs)

The results presented above are also summarized and compared in Table 29. Given the benefits achieved by our proposed “Dual Transmission mode cell” approach, we can conclude that our approach significantly outperforms the other competing approaches also when a vehicular urban environment is used.

Table 29 MBMS Provision – Scenario 3: Summary of Results presented

		UE Counting	Power Counting	FACH with Power Control	Rate Splitting	Dual transmission mode cell
Average Downlink Capacity Requirements	70 UEs present in the cell	2.022 watts (91.3% more)	2.022 watts (91.3% more)	1.234 watts (16.7% more)	1.185 watts (12.1% more)	1.057 watts
	40 UEs present in the cell	2.022 watts (141% more)	1.869 watts (122.76% more)	0.963 watts (14.78% more)	1.185 watts (41.23% more)	0.839 watts
	20 UEs present in the cell	2.022 watts (156.92% more)	1.225 watts (55.65% more)	0.970 watts (23.25% more)	1.041 watts (32.27% more)	0.787 watts
Average Channel Quality Experienced	70 UEs present in the cell	11.15 dB (2.23 dB less)	11.15 dB (2.23 dB less)	12.74 dB (0.64 dB less)	12.91 dB (0.47 dB less)	13.38 dB
	40 UEs present in the cell	11.15 dB (2.77 dB less)	11.29 dB (2.63 dB less)	13.31 dB (0.61 dB less)	12.91 dB (1.01 dB less)	13.75 dB
	20 UEs present in the cell	11.15 dB (2.96 dB less)	12.68 dB (1.43 dB less)	13.32 dB (0.79 dB less)	13.23 dB (0.98 dB less)	13.79 dB
QoS supported for all users		Yes	Yes	Yes	No	Yes
Context Reporting Request Process (70 UEs present in the cell)	Average number of UEs required to report		45	31	27	8
	Average amount of time required for Context Reporting to finish		84.215 ms	61.936 ms	56.054 ms	33.773 ms
	Aggregated Battery consumption by all the Terminals		9.858 watts	48.577 watts	5.662 watts	5.209 watts
	Average Terminal Battery consumption		0.145 watts (3.63% of battery life)	0.714 watts (17.85% of battery life)	0.083 watts (2.07% of battery life)	0.076 watts (1.9% of battery life)
	Aggregated Uplink Noise rise (femtowatts)		53226 femtowatts	77319 femtowatts	19500 femtowatts	1058 femtowatts

#### 4.8.2.4 Scenario 4: Pedestrian urban environment with mix traffic

The results collected from Scenario 4, relate to the indirect gains that can be achieved on the downlink transmission power used for unicast services when each approach is applied for the provision of the MBMS service within a cell.

From the results illustrated below (see Figure 73) we observe that when our proposed “Dual Transmission mode cell” approach is applied, the downlink interference caused in the

cell is reduced. Due to the reduction achieved on the downlink interference caused, the downlink transmission power required to support the UEs receiving unicast services is also reduced since less downlink transmission power is needed to provide the required SNIR (Signal to Noise plus Interference Ratio) at the receiver. As illustrated in Figure 74 when the proposed “Dual Transmission mode cell” approach is applied the average downlink transmission power used for unicast services is 2.618 watts. However, when Rate Splitting approach is applied the average downlink transmission power used for unicast services is 2.665 watts (1.8% more power), when the FACH with power control is applied is 2.699 watts (3.1% more power), when the Power Counting is applied is 2.813 watts (7.45% more power) while when the UE Counting approach is applied is 2.832 watts (8.17% more power).

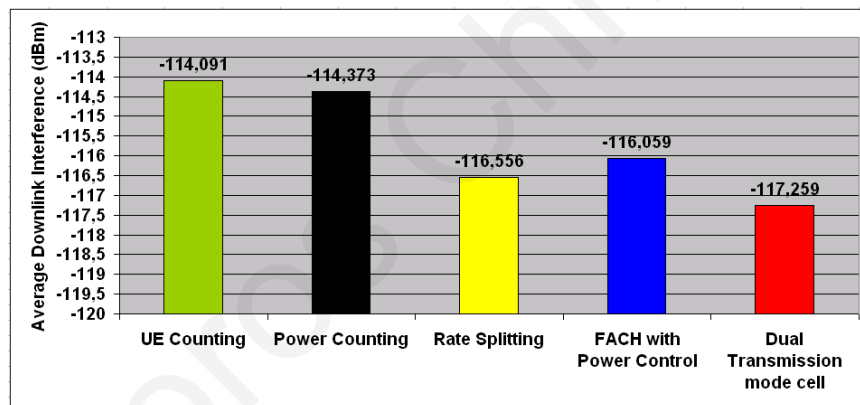

Figure 73 MBMS Provision - Scenario 4 Results: Average Downlink Interference (dBm)

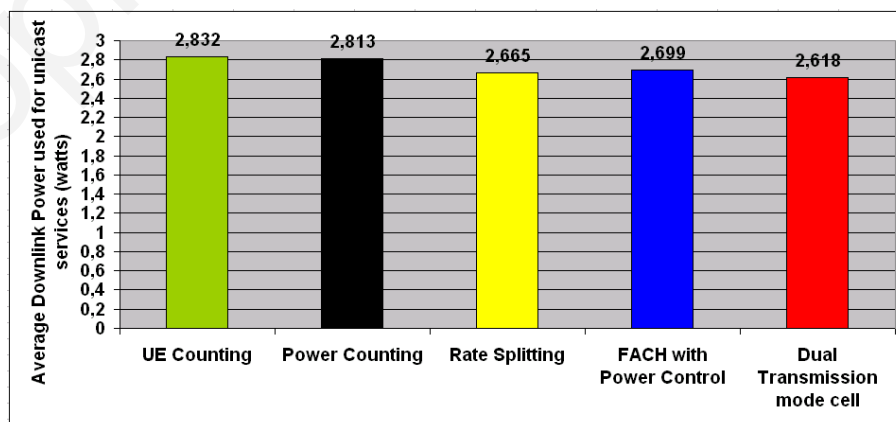

Figure 74 MBMS Provision - Scenario 4 Results: Average Downlink Power for unicast services (watts)

#### 4.9 Concluding Remarks

In this chapter we introduce the “Dual Transmission mode cell” concept in the MBMS service provisioning and propose a new radio resource allocation algorithm in order to efficiently manage the radio resources of this new type of cell. With this new concept, in contrast with all the other related approaches, P-t-M and P-t-P transmissions are allowed to coexist within the same cell and dynamically adapt through time. The main idea of introducing this new type of cell in the MBMS service provisioning is to take full advantage of the benefits that both transmission types can offer (i.e., the capacity benefits of FACH and the fast power control of DCH) and achieve increased radio network capacity and performance.

The radio resource allocation algorithm we propose allows part of the cell’s area to be supported using FACH (“FACH supported area”) while the rest of it is supported using DCHs (“DCH supported area”). Both at session initiation and also during the session, the size of these areas is dynamically adapted (shrink or expand by adapting the transmission power devoted to FACH and by releasing or establishing DCH connections) based on context reports received by the MBMS users indicating their instantaneous distribution and movement within the cell. The aim is to support, throughout the MBMS session, the requested Quality of Service (QoS) to all the MBMS users with the least amount of transmission power (i.e., capacity) consumption.

The context reporting request process is of extreme importance since if not treated with care, uplink congestion, increased uplink noise, increased terminal battery consumption, late decision making and redundant processing effort (in the RNC) is likely to occur. Thus, in order to further enhance efficiency and make our solution scalable a new context reporting request process was proposed and integrated in our “Dual Transmission mode cell” approach,

Moreover, with the “Dual Transmission mode cell” approach we proposed in this chapter, mobility issues arise in terms of intra-cell handovers (i.e., handovers between the FACH and the DCH supported areas) that we also analysed and addressed.

The proposed algorithms have been implemented in OPNET Modeller 11.0.A (see Appendix C) and simulated assuming an urban environment using different speeds (pedestrian, low vehicular and vehicular) and different loads (low – 20 UEs, medium – 40 UEs, high – 70 UEs) in the cell. Note that in the same simulator we also implemented the “UE Counting” the “Power Counting”, the “Rate Splitting” and “FACH with Power Control” approaches. The performance evaluation carried out, comparing our proposed approach with all the other related approaches, showed that our proposed “Dual Transmission mode cell” approach, provides considerable gains and outperforms all other related proposed approaches in terms of capacity and link performance efficiency, thus highlighting its feasibility, importance and usefulness in the MBMS service provisioning.

Moreover, by adopting our proposed context reporting request process, we significantly reduced the time required for the Information Collection step to be performed (since the amount of context reports required to be received for a decision to be made is reduced), reduced the processing effort and the time required by the RNC for making a decision (since less context reports are considered), reduced the uplink interference introduced and lessened the possibility for congestion in the uplink (since not all the UEs are notified for reporting at the same time) and reduced the terminal’s battery consumption (since the need for frequent context reporting by the UEs is eliminated). Thus, even in situations where a large number of MBMS users are present in the cell, scalability and improved system performance is achieved.

## **Chapter 5**

### **Conclusions and Future Work**

The general objective of this Ph.D. dissertation was to investigate and propose efficient, scalable and effective RRM algorithms that will facilitate efficient multicast service provisioning within the radio access part of the UMTS networks. In particular, during our Ph.D. research we focused on the area of Handover Control and Power Control. We analyse the new features introduced with MBMS, identify the new factors that can influence the overall network capacity and performance during the MBMS provision and proposed new algorithms and solutions for controlling parameters such as transmit power, channel allocation, and handover criteria, facilitating decisions targeting to increased network capacity and performance, as well as best QoS for the MBMS users, during the MBMS service provisioning.

In section 5.1, the work accomplished during our research work in order to achieve the objectives of this Ph.D. thesis as well as the main findings and contributions are briefly presented. Section 5.2 identifies opportunities for future work.



## 5.1 Main Findings and contributions

Our research work was performed in two parts. During the first part of our research we deal with MBMS handover control, while during the second part of our research we deal with the efficient MBMS service provision in UTRAN.

During our research on MBMS handover control, we analysed the new mobility issues introduced with MBMS and identified the new types of handovers introduced, that is handovers between P-t-P (DCH) and P-t-M (FACH) transmission mode cells. These new types of handovers imposed new challenges (in term of network capacity, system performance and QoS) in the MBMS handover procedure that cannot be efficiently addressed by the current 3GPP specified handover control solution [8][9] due to the approach used. In the current 3GPP approach only the characteristics of the DCH (which offers fast power control) are considered and the handover triggering criterion is based on a comparison made between the CPICH signal quality received from the Base Stations taking part in the handover procedure. However, a vital aspect for achieving efficient MBMS handovers' execution lies in the consideration of the FACH capacity benefits and its bounded coverage characteristic, a feature not considered by the current 3GPP specified handover control approach or any other approach in the open literature.

Thus by taking into consideration the FACH's capacity benefit and its bounded coverage characteristics we formulated the problem and proposed a new handover control approach to provide a more efficient MBMS handover execution (in terms of capacity, link performance and QoS). Our approach, instead of having as the main input of the handover triggering the comparison of the CPICH signal quality received from the BSs that take part in the handover procedure, considers only the CPICH  $E_c/N_0$  signal quality received from the P-t-M transmission mode cell. This is a vital concern, since the main idea is to reduce the transmission power required in the P-t-P transmission mode cells by taking full advantage of the capacity benefits that FACH (i.e., the P-t-M transmission mode cells) can offers.

By considering a number of dynamic parameters (i.e., CPICH Ec/No Alteration Rate, Pre-Trigger Predictor, Safety Margin, Activation Hysteresis, possibility  $p$  of an erroneous handover triggering to occur), which are influenced by the UE's movement, a threshold value (i.e., the Handover Trigger Threshold (HTT)) is dynamically estimated by our algorithm running in the UE and continually compared with the CPICH Ec/No signal quality measured from the P-t-M transmission mode cell. The aim of this threshold is to force the UE to stay tune to FACH as long as its signal strength is adequate (in case the UE is handing over from a P-t-M to a P-t-P transmission mode cell), or tune to FACH as soon as its signal strength becomes adequate (in case the UE is handing over from a P-t-P to a P-t-M transmission mode cell), to guarantee the reception of the service with the required QoS.

The proposed MBMS handover algorithm has been implemented in OPNET Simulator 11.0.A and evaluated using a series of simulations. In these simulations we have compared our proposed MBMS handover approach with the current 3GPP specified one and obtained results demonstrating significant benefits on:

- The **downlink network capacity**: Significant transmission power savings have been achieved; up to 65% less transmission power used.
- The **downlink channel quality experienced** by the UEs: Due to a reduction achieved on the downlink transmission power used, the inter-cell interference caused in the P-t-M transmission mode cell is also reduced resulting in a channel quality improvement in the P-t-M transmission mode cells of up to 1.5dB.
- The **QoS experienced by the users**: By considering the bounded coverage of FACH in the handover triggering threshold, the handover is executed before the FACH signal strength become inadequate for decoding the signal correctly and thus avoided any QoS degradation during an MBMS handover.

Since WCDMA is interference-limited the aforementioned gains achieved, reflect to an increase on the overall system capacity, whilst maintaining a satisfactory service quality. In

wireless/mobile environments where the radio resources are limited, any capacity increase and QoS improvement is of major importance.

The second part of our research is on the efficient MBMS service provision in UTRAN. This part was further subdivided into two phases. During the first phase we deal with the efficient radio resource allocation during MBMS service provision in UTRAN and in the second one with a new efficient context reporting request process.

Through a number of representative scenarios we motivated the need for a new MBMS service provision approach, by highlighting the inefficiencies that can occur with the current 3GPP specified one [2]. Thus, we proposed a new MBMS service provision approach to address them. Our approach introduces a new type of cell in the MBMS service provisioning, called the “Dual Transmission mode cell”, in which P-t-P (i.e., multiple DCHs) and P-t-M (i.e., FACH) transmissions can coexist and are allowed to dynamically adapt during the session. The main idea of introducing this new type of cell is to take full advantage of the benefits that both transmission types can offer (i.e., the capacity benefits of FACH and the fast power control of DCH) and achieve increased radio network capacity and performance.

The “Dual Transmission mode cell” allows part of the cell’s area to be supported using FACH (“FACH supported area”) while the rest of it is supported using DCHs (“DCH supported area”). Both at session initiation and also during the session, the size of these areas is dynamically adapted (shrinks or expands by adapting the transmission power devoted to FACH and by releasing or establishing DCH connections), according to the instantaneous distribution and movement of the MBMS users within the cell, aiming to always support the requested Quality of Service (QoS) for all the MBMS users with the least amount of transmission power (i.e., capacity) consumption. This new approach raised new mobility issues, more specifically intra-cell handovers between the “FACH supported area” and the “DCH supported area” that we also analysed and proposed a new intra-cell handover algorithm to address them.

The proposed “Dual Transmission mode cell” approach has been implemented in OPNET Modeller 11.0.A and evaluated using a series of simulations. The performance evaluation carried out showed that our proposed “Dual Transmission mode cell” approach, provides considerable gains, as well as outperforming all other related approaches, such as “UE Counting”, “Power Counting”, “Rate Splitting”, and “FACH with Power Control”, in terms of:

- **Downlink network capacity:** Significant reduction on the average downlink transmission power used in the cell has been achieved compared to all other related approaches. For the presented scenarios we observed the following:
  - Up to 65% less downlink transmission power used than the “UE Counting”
  - Up to 59% less downlink transmission power used than the “Power Counting”
  - Up to 41% less downlink transmission power used than the “FACH with Power Control”
  - Up to 33% less downlink transmission power used than the “Rate Splitting” (However, note that with this approach the QoS is not fully supported for all the MBMS users)
- **Channel quality experienced** by the UE: Due to a reduction achieved on the downlink transmission power required for the provision of the MBMS service within the cell the downlink intra-cell interference is also reduced. Thus, significant improvements on the average downlink channel quality experienced by the UEs have been achieved compared to all other related approaches. For the presented scenarios we observed the following:
  - Up to 3.59 dB improvement compared to the “UE Counting”
  - Up to 2.76 dB improvement compared to the “Power Counting”
  - Up to 1.76 dB improvement compared to the “FACH with Power Control”
  - Up to 1.21 dB improvement compared to the “Rate Splitting”

However, the tradeoff (with our initial effort to provide the “Dual Transmission mode cell” approach solution) were a small increase in the terminal battery consumption and the uplink noise rise due to the context reporting request process adopted (i.e., context reports were required to be received by all the MBMS users within the cell in order for a decision to be made). Note that the context reporting request process we initially adopted is the one used by the current 3GPP specified MBMS service provision approach which is described in [2].

Thus, to further enhance our “Dual Transmission mode cell” approach, achieve scalability and lessen the aforesaid tradeoffs, we proposed a new context reporting request process that managed to outperform all other related approaches (note that the “UE Counting” is not considered here), in all respects. With the new context reporting request process integrated, our proposed “Dual Transmission mode cell” approach, in addition to the capacity and channel quality gains previously mentioned, it also outperformed all other related approaches and:

- **Reduced the Terminal’s battery consumption:** By reducing the need for frequent context reporting by the UEs significant improvements on the terminal’s battery life have been achieved compared to all other related approaches. For the presented scenarios we observed the following:
  - **Proposed “Dual Transmission mode cell”:** Average of up to **1.9% consumption** of the terminal’s battery life
  - **“Power Counting”:** Average of up to **3.63% consumption** of the terminal’s battery life
  - **“FACH with Power Control”:** Average of up to **17.85% consumption** of the terminal’s battery life
  - **“Rate Splitting”:** Average of up to **2.07% consumption** of the terminal’s battery life
- **Reduced the number of reports required (and thus the number of the UEs that have to report) for a decision to be made, every time context reporting is**

**required, and thus lessen also the possibility for uplink congestion** (since not all the UEs are notified for reporting at the same time). For the presented scenarios we observed the following:

- **Proposed “Dual Transmission mode cell”**: Average of up to **9 context reports** required to be received for a decision to be made.
  - **“Power Counting”**: Average of up to **50 context reports** required to be received for a decision to be made.
  - **“FACH with Power Control”**: Average of up to **36 context reports** required to be received for a decision to be made.
  - **“Rate Splitting”**: Average of up to **29 context reports** required to be received for a decision to be made.
- **Reduced the uplink interference introduced**: Since less context reports are required for a decision to be made less interference is introduced in the uplink during context reporting. For the presented scenarios we observed the following:
    - **Proposed “Dual Transmission mode cell”**: Aggregated uplink interference caused of up to **1058 femtowatts**
    - **“Power Counting”**: Aggregated uplink interference caused of up to **53226 femtowatts**
    - **“FACH with Power Control”**: Aggregated uplink interference caused of up to **77319 femtowatts**
    - **“Rate Splitting”**: Aggregated uplink interference caused of up to **19500 femtowatts**
  - **Reduced the processing effort required in the RNC as well as the time required for context reporting to finish** (since less context reports are considered) and thus **achieved faster decision making**. For the presented scenarios we observed the following:

- **Proposed “Dual Transmission mode cell”**: Average time required for context reporting process to finish of up to **33.888 ms**
- **“Power Counting”**: Average time required for context reporting process to finish of up to **90.466 ms**
- **“FACH with Power Control”**: Average time required for context reporting process to finish of up to **75.569 ms**
- **“Rate Splitting”**: Average time required for context reporting process to finish of up to **59.866 ms**

Since not only the downlink capacity and channel quality improvements but also the uplink interference, the terminal’s battery life and fast decision making are also considered as critical factors in the MBMS service provision efficiency, the aforesaid gains achieved by our proposed “Dual Transmission mode cell” approach, highlights its feasibility, importance and usefulness in the MBMS service provisioning.

## 5.2 Future work

High Speed Downlink Packet Access (HSDPA) [47][48] and Multimedia Broadcast multicast service (MBMS) systems are two of the most important steps of the UMTS Network evolution. HSDPA by providing UMTS network with a more flexible and efficient method for utilizing radio resources manages to achieve significant improvements on the downlink system capacity, reduced network latency and higher data rates for packet data services. On the other hand, MBMS by providing UMTS network with a powerful tool to offer broadcast and multicast services (e.g., Mobile TV) efficiently, achieves significant core- and radio-resource saving. However, the existing MBMS solution, that utilizes UMTS Release 99 channels (DCH and FACH) for the content provision, is not very flexible in terms of radio resource usage (codes and capacity allocation). In order to introduce more flexibility on the way radio resources are allocated, a good solution for the efficient MBMS Service provision in UTRAN, is the utilization of HSDPA.

Currently there is discussion in the standards bodies for using the HSDPA (High-Speed Downlink Packet Access) for the distribution of MBMS services in the cells, but as of present there is nothing standardised. Some authors in [49][50][51] have investigated this issue but nothing has been proposed concerning how radio resources will be allocated for the MBMS content provision or how mobility will be handled between HSDPA MBMS enabled cells.

Moreover, the HSDPA is not a replacement of the original WCDMA R99/R4 system (DCH, FACH) but an additional function to it. Taking into consideration the aforementioned, handovers from HS-DSCH to DCH or FACH (or vice versa) may potentially be needed for MBMS users that are moving from a cell with HSDPA (HS-DSCH) to a cell without HSDPA (DCH or FACH). A handover algorithm dealing with the aforementioned type of handovers has not been proposed yet. Thus the study of an efficient handover algorithm that deals with these types of handovers is also a challenge.

The aforesaid are two of the most important open issues that are worth studying. Therefore, future work will include monitoring standardization progress in using HSDPA for the MBMS bearer services provision and the extension of our algorithms accordingly.

Moreover, with the introduction of Long Term Evolution (LTE), MBMS has become an attractive option for operators who want to increase bandwidth capacity and improve service quality without having to make a costly investment in receiver hardware or network infrastructure. LTE is a set of enhancements to the UMTS Release 8 specifications [71] which promises the delivery of rich multimedia services in a more power and spectral efficient way:

- Increased spectral efficiency and capacity
  - Expected to deliver three to five times more capacity than Release 6.
- Reduced delays
  - RAN round-trip times of less than 10 ms.
- Higher data rates
  - Downlink peak rates of at least 100 Mbps,
  - Uplink peak rates of at least 50 Mbps



- Flexible spectrum allocations
  - Supports scalable carrier bandwidths, from 1.4 MHz to 20 MHz

With the introduction of LTE, MBMS is now an attractive option for operators who finally have enough bandwidth to cope with demand. After deploying LTE, the next logical step, according to most operators' roadmaps, is to deploy Enhanced (E)-MBMS in their network.

An initial LTE design requirement was to support an enhanced version of MBMS compared to UMTS Release 6. The targets included cell-edge spectrum efficiency in an urban or suburban environment of 1 bit/Hz – equivalent to the support of at least 16 Mobile TV channels at around 300Kbps per channel in a 5 MHz carrier. This is only achievable by exploiting the special features of the LTE Orthogonal Frequency Division Multiplexing (OFDM) air interface in a Single Frequency Network (SFN) mode. OFDM is used as well in WLAN, WiMAX and broadcast technologies like DVB. OFDM has several benefits including its robustness against multipath fading and its efficient receiver architecture. It was also recognized that the user experience is not purely determined by the data rate achieved, but also by other factors, such as the interruption time when switching channels. This has implications for the design of the MBMS control signalling, which is also being extensively redesigned for LTE.

The feature in LTE to exploit the OFDM radio interface to transmit multicast or broadcast data as a multicell transmission over a single-frequency synchronized network is termed as MBSFN: Multimedia Broadcast Single Frequency Network. In MBSFN operation, MBMS data is transmitted simultaneously over the air from multiple, tightly time-synchronized cells. A UE receiver will therefore observe multiple versions of the signal with different delays, due to the multicell transmission. Provided that the transmissions from the multiple cells are sufficiently tightly synchronized for each to arrive at the UE within the cyclic prefix at the start of the symbol, there will be no Inter Symbol Interference (ISI). In effect, this makes the MBSFN transmission appear to a UE as a transmission from a single large cell, and the UE

receiver may treat the multicell transmissions in the same way as multipath components of a single-cell transmission without incurring any additional complexity. The UE does not even need to know how many cells are transmitting the signal.

This Single Frequency Network reception leads to significant improvements in spectral efficiency compared to UMTS Release 6 MBMS, as the MBSFN transmission greatly enhances the Signal to Interference plus Noise Ratio (SINR). This is especially true at the cell edge, where transmissions which would otherwise have constituted inter-cell interference are translated into useful signal energy – hence the received signal power is increased at the same time as the interference power being largely removed.

To this direction, the newly introduced E-MBMS framework is envisaged to play a fundamental role during the LTE standardization. Therefore we plan to monitor standardization progress of MBMS in LTE and extent our algorithms accordingly.

Furthermore, the technological advances and market developments in the wireless communications area during the last years led to the 4th Generation (4G) Networks which encompasses network heterogeneity. In a wireless heterogeneous network, a plethora of different Radio Access Technologies (RATs) will have to co-exist, overlap and be interconnected, in order to provide to the end user independence and flexibility with the possibility to connect to the “best” point of attachment anytime, anywhere and anyhow.

In the future, users receiving an MBMS service will be able to access the network through a heterogeneous landscape of Radio Access Technologies (RATs) like WLAN, Wimax, UMTS, etc.. Until now, Network Operators of 2G and 3G networks have only considered local RRM strategies for the resource management of their own networks. However, with the convergence of different RATs into a mixed architecture, an environment has been created where the Network Operators need to manage resources of different RATs simultaneously, thus raising the concept of Common RRM [54]-[68]. In the aspect of implementation, each RAT has functions for local resource management (i.e., horizontal handovers, resource allocation, etc.) and under the strategy of Common RRM each RAT is managed globally (i.e.,

common resource allocation, RAT selection functionality for newly entering or users with an ongoing connection, etc.).

The heterogeneous network is conceptually a very attractive notion; however, with this kind of mixed architecture, design of efficient Radio Resource Management (RRM) algorithms that will achieve efficient coupling between the different RATs of different characteristics is a challenge. The RRM problem is inherent to any stand-alone wireless system and it has been extensively researched in the past and mainly considered only for unicast transmissions. However, with different RATs inter-connected and co-existing in the same service area, and multicast transmissions in this heterogeneous environment, the RRM problem becomes more complex, necessitating more advanced solutions both for common and local resource management. Thus this is a subject with major importance and is a challenge for further investigation.

The new RRM algorithms should achieve optimization, harmonization and integration of different RATs and multicast services, provide the end user with seamless service continuity (i.e., vertical and horizontal handovers, RAT selection functionality, etc.) and manage heterogeneous radio resources in an integrated fashion aiming to an optimum network capacity and performance.

## Bibliography

- [1] 3GPP TS 23.246 V9.1.0, “3rd Generation Partnership Project; Technical Specification Group Services and System Aspects; Multimedia Broadcast/Multicast Service (MBMS); Architecture and functional description (Release 9)”, June 2009.
- [2] 3GPP TS 25.346 V8.3.0, “3rd Generation Partnership Project; Technical Specification Group Radio Access Network; Introduction of the Multimedia Broadcast Multicast Service (MBMS) in the Radio Access Network (RAN); Stage 2 (Release 8)”, March 2009.
- [3] 3GPP TS 23.101 v9.0.0, “3rd Generation Partnership Project; Technical Specification Group Services and System Aspects: General Universal Mobile Telecommunications System (UMTS) architecture (Release 9)”, December 2009.
- [4] 3GPP TS 22.146 V9.0.0, “3rd Generation Partnership Project; Technical Specification Group Services and System Aspects; Multimedia Broadcast/Multicast Service; Stage 1 (Release 9)”, June 2008.
- [5] 3GPP TS 22.246 V8.5.0, “3rd Generation Partnership Project; Technical Specification Group Services and System Aspects; Multimedia Broadcast/Multicast Service (MBMS) user services; Stage 1 (Release 8)”, March 2008.
- [6] 3GPP TR 23.846 6.1.0, “3rd Generation Partnership Project; Technical Specification Group Services and System Aspects; Multimedia Broadcast/Multicast Service (MBMS); Architecture and functional description (Release 6)”, December 2002.
- [7] 3GPP TSG RAN WG2 #29 “Considerations on power allocation for MBMS”, Samsung, R2-021669, June 2002.
- [8] 3GPP TR 25.922 V7.1.0, “3rd Generation Partnership Project; Technical Specification Group Radio Access Network; Radio resource management strategies (Release 7)”, March 2007.
- [9] 3GPP TS 25.331 V9.1.0, “Technical Specification Group Radio Access Network; Radio Resource Control (RRC); Protocol Specification (Release 7)”, December 2009.

- [10] A. Panayides, C. Christophorou, J. Antoniou, A. Pitsillides, V. Vassiliou, "Power Counting for Optimized Capacity in MBMS Enabled UTRAN", IEEE Symposium on Computers and Communications 2008 (ISCC'08), July 6 - 9, 2008, Marrakech, Morocco, Pages:368 – 373.
- [11] B-BONE, Deliverable 3.2, "Report on Broadcast/Multicast RAN Resource Management Algorithms", August 2005.  
[http://seacorn.cs.ucy.ac.cy/bscw/bscw.cgi/d108910/WP3\\_AUEB\\_D32.doc](http://seacorn.cs.ucy.ac.cy/bscw/bscw.cgi/d108910/WP3_AUEB_D32.doc)
- [12] 3GPP TSG RAN WG2 #31, "MBMS Power Usage", Lucent Technologies, R2-022110, August, 2002.
- [13] S. Armando, S. Nuno, C. S. Joao, E. Patricia, C. Americo, "Effective Radio Resource Management for MBMS in UMTS Networks", An International Journal on Wireless Personal Communications, Volume 42 , Issue 2 (July 2007), Pages: 185 – 211, 2007.
- [14] 3GPP TSG-RAN WG1#29, "Power Control for FACH," Lucent Technologies, R1-021324, November 2002.
- [15] 3GPP TSG RAN WG1#28bis, "Power Usage for Mixed FACH and DCH for MBMS," Lucent Technologies, R1-02-1240, October, 2002.
- [16] M. Chuah, T. Hu, W. Luo, "UMTS Release 99/4 airlink enhancement for supporting MBMS services", IEEE International Conference on Communications 2004 (ICC 2004), Paris, France, June 2004, Volume: 6, Pages: 3231- 3235.
- [17] C. Bouras, A. Alexiou, V. Kokkinos, "Power saving techniques in mbms multicast mode", 3rd ACM Workshop on Wireless Multimedia Networking and Performance Modeling 2007 (WMuNeP'07), Chania, Crete Island, Greece, October 22 - 22, 2007, Page(s): 62 – 69.
- [18] C. Christophorou, A. Pitsillides, "A new Approach for Efficient MBMS Service Provision in UTRAN", IEEE Symposium on Computers and Communications 2008 (ISCC'08), 6-9 July 2008, Marrakech, Morocco, Pages: 356 – 361.
- [19] C. Christophorou, A. Pitsillides, V. Vassiliou, "An Enhanced Radio Resource Allocation Approach for Efficient MBMS Service Provision in UTRAN", IEEE International Symposium on Personal, Indoor and Mobile Radio Communications 2008 (PIMRC 2008), 15-18 September 2008, Cannes, French Riviera, France, ISBN: 978-1-4244-2643-0, Pages: 1 - 5.
- [20] C. Christophorou, A. Pitsillides, T. Lundborg, "Enhanced Radio Resource Management Algorithms for Efficient MBMS Service Provision in UTRAN", Elsevier Computer Networks Journal (COMNET), February 2011, Volume: 55, Issue: 3, Pages: 689 – 710, DOI information: <http://dx.doi.org/10.1016/j.comnet.2010.10.010>.
- [21] C. Christophorou, A. Pitsillides, "An enhanced MBMS service provision approach for improved performance in UTRAN", 18th International Conference on Telecommunications (ICT 2011), 8 – 11 May 2011, Ayia Napa, Cyprus, Pages: 526 – 531.
- [22] H. Kaaranen, A. Ahtiainen, L. Laitinen, S. Naghian, V. Niemi, "UMTS Networks: Architecture, Mobility and Services", Second Edition, John Wiley & Sons Ltd, The

Atrium, Southern Gate, Chichester, West Sussex PO19 8SQ, England, 2005, ISBN 0-470-01103-3.

- [23] J. Schiller, "Mobile Communications", Second Edition, Addison - Wesley, PEARSON EDUCATION LIMITED, Edinburgh Gate, Harlow CM20 2JE, 2003, ISBN 0-321-12381-6.
- [24] Hsiao-Hwa Chen, "The Next Generation CDMA Technologies", John Wiley & Sons Ltd, The Atrium, Southern Gate, Chichester, West Sussex PO19 8SQ, England, 2007, ISBN 978-0-470-02294-8 (HB).
- [25] H. Holma, A. Toskala, "WCDMA For UMTS: Radio Access for Third Generation Mobile Communications", Third Edition, John Wiley & Sons Ltd, The Atrium, Southern Gate, Chichester, West Sussex PO19 8SQ, England, 2004, ISBN 0-470-87096-6.
- [26] M. Hauge, K. Øyvind, "Multicast in 3G networks: Employment of Existing IP Multicast Protocols in UMTS", International Workshop on Wireless Mobile Multimedia, SESSION: Unicast and Multicast in Next Generation Wireless, Atlanta, Georgia, USA, 2002, Pages: 96 – 103.
- [27] J. Wang, J. C. Liu, Y. Cen, "Analysis of Soft Handoff Algorithms with Dynamic Spreading WCDMA System", 17th International Conf. on Advanced Information Networking and Applications, 2003, ISBN: 0-7695-1906-7.
- [28] I. A.Tomić, M. L. Dukić, "Soft Handover and Downlink Capacity in UMTS Network", XII Telekomunikacioni forum TELFOR 2004, Beograd, Sava Centar, November 2004, 23.-25.11.2004.g.
- [29] X. Yang, J.H. Yap, S. Ghaheri-Niri, R. Tafazolli, "Enhanced position assisted soft handover algorithm for UTRA", IEEE Vehicular Technology Conference 2001, VTC 2001 Fall, IEEE VTS 54th, Volume: 2, Pages: 567 – 571.
- [30] M. Ismail, N. Aripin, "Downlink soft handover performance for different cell selection schemes in WCDMA system", IEEE Malaysia International Conference on Communications and IEEE International Conference on Networks, 16 – 18 Nov. 2005, Volume 2, Pages: 808 – 811.
- [31] A. Soares, A. Correia, J.C. Silva, N. Souto, "UE Counting Mechanism for MBMS Considering PtM Macro Diversity Combining Support in UMTS Networks", 2006 IEEE Ninth International Symposium on Spread Spectrum Techniques and Applications, Aug. 2006, Pages: 361 – 365.
- [32] N. Souto, A. Soares, P. Eusébio, A. Correia, J.C. Silva, "Effective Radio Resource Management for Multimedia Broadcast/Multicast Services in UMTS Networks", EURASIP Journal on Wireless Communications and Networking Volume 2006 (2006), Article ID 70903 (12 Pages), October 2006.
- [33] N. Pratas, A. Rodrigues, "Enhancement of MBMS through Macro Diversity Schemes in a Microcell Environment", 4th International Symposium on Wireless Communication Systems, 2007 (ISWCS 2007), 17-19 October 2007, Pages: 727 – 731.
- [34] C. Christophorou, Andreas Pitsillides, "MBMS Handover Control for Efficient Multicasting in IP-Based 3G Mobile Networks", IEEE International Conference on

Communications 2006 (ICC 2006), 11-15 June, Istanbul, Turkey, Volume 5, Pages: 2112 – 2117.

- [35] C. Christophorou, Andreas Pitsillides, “An Efficient Handover Algorithm for MBMS Enabled 3G Mobile Cellular Networks”, IEEE Symposium on Computers and Communications (ISCC'06), June 26-29, Pula-Cagliari, Sardinia, Italy, Pages: 187 – 193.
- [36] A. Pitsillides, C. Christophorou, “MBMS Handover Control: A New Approach for Efficient Handover in MBMS Enabled 3G Cellular Networks”, Elsevier Computer Networks Journal (COMNET), December 2007, ISSN: 1389-1286, Volume 51, Issue: 18, Pages: 4897-4918. DOI information: <http://dx.doi.org/10.1016/j.comnet.2007.08.005>
- [37] C. Christophorou, A. Pitsillides “Radio Resource Management in MBMS Enabled 3G Mobile Cellular Networks: A New Handover Control Approach”, 13th European Wireless 2007, Paris, France, April 2007, CD – ROM Proceedings, ISBN: 2-912328-41-1 (7 pages).
- [38] C. Christophorou, A. Pitsillides, N. Binucci, “Handover Control in MBMS Enabled 3G Mobile Cellular Networks”, 16th IST Mobile Summit & Wireless Communication Summit, Budapest, Hungary, 1-5 July 2007, CD – ROM Proceedings, ISBN: 978-963-8111-66-1 (5 pages)
- [39] C. Christophorou, A. Pitsillides, “An Enhanced Approach for Efficient MBMS Handovers in 3G Networks”, IEEE Symposium on Computers and Communications 2008 (ISCC'08), July 6 - 9, 2008, Marrakech, Morocco, Pages: 362 – 367.
- [40] C. Christophorou, A. Pitsillides, “A NEHO based MBMS Handover Control Approach”, IEEE International Symposium on Personal, Indoor and Mobile Radio Communications 2008 (PIMRC 2008), 15-18 September 2008, Cannes, French Riviera, France, ISBN: 978-1-4244-2643-0, Pages: 1 - 5.
- [41] J. Hung-Hui, H. Ching-Yao, “Adaptive UMTS Handover Control Algorithm in Third Generation Wireless Systems”, Fifth International Conference on Information, Communications and Signal Processing 2005, December 2005, Pages: 607 – 612.
- [42] S. K. Kim, C. G. Kang, K. S. Kim, “An adaptive handover decision algorithm based on the estimating mobility from signal strength measurements”, IEEE 60th Vehicular Technology Conference, Volume 2, 26-29 Sept. 2004, Pages: 1004 – 1008.
- [43] C. Chaikalis, “Efficient TTI for 3G Multimedia applications”, Advances in Multimedia, Hindawi Publishing Corporation, New York, United States, Year of publication: 2007, Volume: 2007, Issue: 1, ISSN 1687-5680.
- [44] Intel® Xeon® Processor 7000 Sequence Technical Documents, “Intel® 64 and IA-32 Architectures, Optimization Reference Manual”, [http://www.intel.com/p/en\\_US/products/server/processor/xeon7000/technical-documents](http://www.intel.com/p/en_US/products/server/processor/xeon7000/technical-documents).
- [45] B-BONE MBMS System Level simulator: <http://b-bone.ptinovacao.pt/docs/BBONE-Reference-Model.rar>, October 2006.
- [46] OPNET University Program: <http://www.opnet.com/services/university/>

- [47] R. Love, A. Ghosh, X. Weimin, R. Ratasuk, "Performance of 3GPP high speed downlink packet access (HSDPA)", IEEE 60th Vehicular Technology Conference 2004 (VTC2004), September 2004, Volume 5, Pages: 3359 – 3363.
- [48] E. Dahlman, M.Sawahashi (2007). Evolution of the WCDMA Radio Access Technology. In Yongwan Park & Fumiyuki Adachi (Eds.), Enhanced Radio Access Technologies for Next Generation Mobile Communication. (pp 191-216). Netherlands, Springer.
- [49] Americo M. C. Correia, Joo C. M. Silva, Nuno M. B. Souto, Lusa A. C. Silva, Alexandra B. Boal, Armando B. Soares, "Multi-Resolution Broadcast/Multicast Systems for MBMS", IEEE Transactions on Broadcasting, March 2007, Volume: 53, Issue:1, Part 2, Pages: 224 – 234.
- [50] L. Silva, P. Gomes, A. Correia, "Point-to-Point MBMS Video Streaming using HSDPA", 6th Conference in Telecommunications 2007, 9 – 11 May, Peniche, Portugal.
- [51] V. Ville, K. Janne, "Point-to-Multipoint Multimedia Broadcast Multicast Service (MBMS) Performance over HSDPA", IEEE 18th International Symposium on Personal, Indoor and Mobile Radio Communications, 2007 (PIMRC 2007), September 2007, Athens, Greece, Pages:1 – 5.
- [52] J. G. Andrews, A. Ghosh, R. Muhamed, "Fundamentals of WiMAX – Understanding Broadband Wireless Networking", Pearson Education Inc., ISBN 0-13-222552-2.
- [53] T. Jiang, W. Xiang, C. Hsiao-Hwa, Q. Ni, "Multicast Broadcast Services Support in OFDMA-Based WiMAX Systems [Advances in Mobile Multimedia]", IEEE Communications Magazine, August 2007, Volume: 45, Issue: 8, Pages: 78-86.
- [54] L. Wu, K. Sandrasegaran, "A Survey on Common Radio Resource Management", IEEE 2nd International Conference on Wireless Broadband and Ultra Wideband Communications (AusWireless 2007), 27-30 Aug. 2007, Sydney, NSW, ISBN: 978-0-7695-2846-5.
- [55] A. Tolli, P. Hakalin, and H. Holma, "Performance Evaluation of Common Radio Resource Management (CRRM)", IEEE International Conference on Communications 2002 (ICC 2002), New York, United States, 2002, Volume:5, Pages: 3429- 3433.
- [56] A. Tolli and P. Hakalin, "Adaptive load balancing between multiple cell layers", IEEE 56th Vehicular Technology Conference 2002 (VTC 002), 2002, Volume: 3, Pages: 1691- 1695.
- [57] A.-E. M. Taha, H. S. Hassanein and H. T. Mouftah, "Exploiting Vertical Handoffs in Next Generation Vertical Handoffs," IEEE International Conference on Communications 2006 (ICC2006), June 2006, Istanbul, Pages: 2083 - 2088.
- [58] X. Gelabert, J. Perez-Romero, O. Sallent, R. Agusti, "On Managing Multiple Radio Access Congestion Events in B3G Scenarios", 65th IEEE Vehicular Technology Conference Spring (VTC2007-Spring), Dublin, Ireland, 22-25 April 2007, Pages: 1137-1141.
- [59] A. Hasib and A. O. Fapojuwo, "Performance Analysis of Common Radio Resource Management Scheme in Multi-service Heterogeneous Wireless Networks", IEEE Wireless Communications and Networking Conference 2007 (WCNC 2007), Pages: 3296 - 3300.



- [60] G. Koundourakis, D.I. Axiotis, and M. Theologou. "Network-based access selection in composite radio environments", IEEE Wireless Communications and Networking Conference 2007 (WCNC 2007), Pages 3877–3883.
- [61] O. Ormond, P. Perry, and J. Murphy. "Network selection decision in wireless heterogeneous networks", IEEE 16th International Symposium on Personal, Indoor and Mobile Radio Communications 2005 (PIMRC 2005), 11-14 September 2005, Volume: 4, Pages: 2680–2684.
- [62] X. Liu, V. O. K. Li, and P. Zhang, "NXG04-4: Joint radio resource management through vertical handoffs in 4G networks", IEEE Global Telecommunications Conference 2006 (GLOBECOM 2006), November 2006, Pages 1–5.
- [63] D. Niyato and E. Hossain, "WLC04-5: Bandwidth allocation in 4G heterogeneous wireless access networks: A non cooperative game theoretical approach", IEEE Global Telecommunications Conference 2006, (GLOBECOM 2006), November 2006, Pages: 1–5.
- [64] J. Antoniou, C. Christophorou, J. Simoes, A. Pitsillides, "Adaptive Network-Aided Session Support in Context-Aware Converged Mobile Networks" International Journal of Autonomous and Adaptive Communication Systems, March 2010.
- [65] J. Antoniou, C. Christophorou, A. Neto, S. Sargento, F. Pinto, N. Carapeto, T. Mota, J. Simoes, A. Pitsillides, "Session and Network Support for Autonomous Context-Aware Multiparty Communications in Heterogeneous Mobile Systems" International Journal of Handheld Computing Research (IJHCR), December 2010, Volume: 1, No: 4, Pages: 1 – 24.
- [66] J. Antoniou, C. Christophorou, C. Janneteau, M. Kellil, S. Sargento, A. Neto, F. C. Pinto, N. F. Carapeto, J. Simoes, "Architecture for Context-Aware Multicast Delivery in Mobile Heterogeneous Networks", International Conference on Ultra Modern Telecommunications 2009 (ICUMT 2009), 12 – 14 October 2009, St. Petersburg, Russia, Print ISBN: 978-1-4244-3942-3, Pages: 1-6.
- [67] J. Antoniou, C. Christophorou, A. Neto, S. Sargento, F. C. Pinto, N. F. Carapeto, T. Mota, J. Simoes, A. Pitsillides, "Context-Aware Self-Optimization in Multiparty Converged Mobile Environments", Third International ICST Conference on Autonomic Computing and Communication Systems (Autonomics 2009), 9-11 September 2009, Cyprus University of Technology, Limassol, Cyprus, Volume: 3, Part:1, Pages: 144 – 159.
- [68] J. Antoniou, C. Christophorou, J. Simoes, A. Pitsillides, "Network-Aided Session Management for Adaptive Context-Aware Multiparty Communications", Book of Formal and Practical Aspects of Autonomic Computing and Networking: Specification, Development and Verification, IGI Global, 2010, (In print, 2011).
- [69] R. Narasimhan and D. Cox, "Speed Estimation in Wireless Systems Using Wavelets", IEEE Transactions on Communications, vol. 47, no. 9, September 1999, pp. 1357-1364.
- [70] C. Laoudias, C. Panayiotou, J. G. Markoulidakis, C. Desiniotis, "Simulation Analysis on the Efficiency of STAMP Method", 1st LIAISON Workshop, September 2006.

- [71] 3GPP TR 25.913 V9.0.0, 3rd Generation Partnership Project; Technical Specification Group Radio Access Network; Requirements for Evolved UTRA (E-UTRA) and Evolved UTRAN (E-UTRAN) (Release 9), December 2009.
- [72] [RFC 3376], Network Working Group, "RFC 3376 - Internet Group Management Protocol, Version 3", <http://www.faqs.org/rfcs/rfc3376.html>.
- [73] [RFC 3973], Network Working Group, "RFC 3973 - Protocol Independent Multicast - Dense Mode (PIM-DM): Protocol Specification (Revised)", <http://www.faqs.org/rfcs/rfc3973.html>.
- [74] [RFC 2362], Network Working Group, "RFC 2362 - Protocol Independent Multicast-Sparse Mode (PIM-SM): Protocol Specification", <http://www.faqs.org/rfcs/rfc2362.html>.

## APPENDIX A: WCDMA RADIO CHANNELS

WCDMA radio access [22] allocates bandwidth for users and the allocated bandwidth and its controlling functions are handled using the term “Channel”. The functionality implemented through WCDMA defines what kinds of channels are required and how they are organised. As shown in Figure 75 the channel organisation used by WCDMA comprises three layers: logical channels, transport channels and physical channels. Of these, logical channels describe the types of information to be transmitted, transport channels describe how the logical channels are to be transferred and physical channels are the “transmission media” providing the radio platform through which the information is actually transferred.

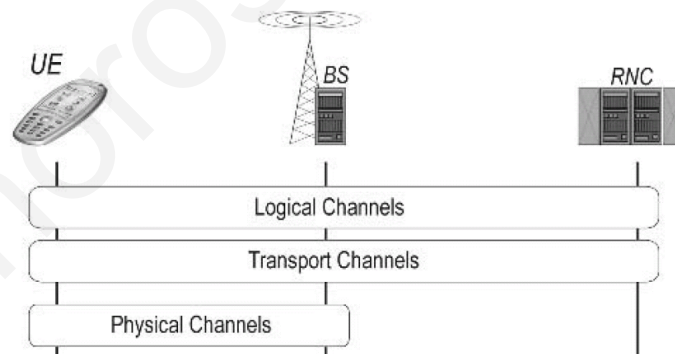

Figure 75 WCDMA Radio Channels

### **Logical channels:**

Logical channels are not actually channels. They can be understood as different tasks the network and the terminal should perform in different moments of time. Here, only the Logical

channels related to the present study are going to be described. The tasks and the Logical channels that are used to perform these tasks are the following:

- Dedicated Control Channel (DCCH): When there is a dedicated, active connection the network sends Control information concerning this connection.
- Dedicated Traffic Channel (DTCH): The dedicated user traffic for one user service in the downlink direction is sent through this logical channel.
- MBMS point-to-multipoint Control Channel (MCCH): This logical channel is used for a p-t-m downlink transmission of control plane information between network and UEs in RRC Connected or Idle Mode. The control plane information on MCCH is MBMS specific and is sent to UEs in a cell with an activated (joined) MBMS service. MCCH can be sent in S-CCPCH carrying the DCCH of the UEs in CELL\_FACH state, or in standalone S-CCPCH, or in same S-CCPCH with MTCH. Short indication is always given to UE to when to read MCCH. UTRAN may use in-band notification instead of the MICH to notify users receiving MTCH. Reception of paging has priority over reception of MCCH for Idle mode and URA/CELL\_PCH UEs.
- MBMS point-to-multipoint Traffic Channel (MTCH): This logical channel is used for p-t-m downlink transmission of user plane information between network and UEs in RRC Connected or Idle Mode. The user plane information on MTCH is MBMS Service specific and is sent to UEs in a cell with an activated MBMS service.

### **Transport Channels:**

There are two types of Transport channels. These are the Common channels and the Dedicated channels:

- Dedicated Channel (DCH): The DCH carry dedicated traffic (DTCH) and control information (DCCH). It should be noted that one DCH might carry several DTCH depending on the case. For example, a user may have a simultaneous voice call and

video call active. The voice call uses one logical DTCH and the video call requires another logical DTCH. Both of these, however, use the same DCH.

- **Broadcast Channel (BCH):** This channel (carries the content of BCCH), broadcast from the Base Station (BS), carries information intended for the whole cell and is hence sent out at fairly high power levels because every terminal in the intended cell coverage area must be able to “hear” it. The UE must be able to decode the BCH in order to register to the network.
- **Random Access Channel (RACH):** A contention based uplink channel used for transmission of relatively small amount of data, e.g. for initial access or non-real time dedicated control or traffic data.
- **Forward Access Channel (FACH):** Common downlink channel without Closed-loop power control used for transmission of relatively small amount of data. This channel carries control information to the UE known to be in the cell. For example, when the RNC receives a random access message (through the RACH) from the terminal, the response is delivered through FACH. In addition to this, the FACH may carry packet traffic in the downlink direction. One cell may contain numerous FACH. Also this channel carries the content of MCCH and MTCH Logical channels.

### **Physical Channels:**

When the information is collected from the Logical channels and organized to the Transport channels it is in ready-to-transfer format. Before transmitting, the Transport Channels are arranged to the Physical Channels. The physical channels are used between the Terminal and the Base Station. The physical channels are:

- **Primary Common Control Physical Channel (P-CCPCH):** Carries the BCH in the downlink direction. The P-CCPCH is available in a way that all the terminals populated within the cell coverage are able to demodulate its contents. It uses a fixed

channelisation code and thus its spreading code is fixed too. This is a must because otherwise the terminals are not able to “see” and demodulate the P-CCPCH.

- Secondary Common Control Physical Channel (S-CCPCH): Carries two transport channels in it: Paging Channel (PCH) and Forward Access Channel (FACH). These transport channels may use the same or separate S-CCPCH, thus a cell always contains at least one S-CCPCH.
- Dedicated Physical Data Channel (DPDCH): Carries dedicated user traffic. The size of the DPDCH is variable and it may carry several calls/connection in it. As the name says, it is a dedicated channel, which means that it is used between the network and one user.
- Dedicated Physical Control Channel (DPCCH): The Dedicated Physical Channels are always allocated as pairs for one connection. The one channel is used for control information transfer and the other for actual traffic. The DPCCH transfers the control information (for example power control information) during the dedicated connection.
- Common Pilot Channel (CPICH): is an unmodulated code channel, which is scrambled with the cell-specific scrambling code. It is used for dedicated channel estimation (by the terminal) and to provide channel estimation reference when common channels are concerned. The terminals listen to the pilot signal continuously and this is why it is used for some “vital” purposes in the system, e.g. handover measurements (the UE always searches the most attractive cells and by decreasing the CPICH power level, the cell is less attractive) and cell load balancing (the CPICH power level adjustment balances the load between cells).
- Paging Indication Channel (PICH): This channel is used to alert the UE of a forthcoming page message.
- MBMS Notification Indicator Channel (MICH): MBMS notification utilizes a new MBMS specific PICH called MBMS Notification Indicator Channel (MICH) in cell. The MBMS notification mechanism is used to inform UEs of an upcoming change in

critical MCCH information. The MBMS notification indicators will be sent on an MBMS specific PICH, called the MICH.

Christophoros Christophoros

## APPENDIX B: MBMS SPECIFIC WCDMA

### LOGICAL CHANNELS

With MBMS, there are two new logical channels, namely:

- MBMS Point-to-Multipoint Control Channel (MCCH)
- MBMS Point-to-Multipoint Traffic Channel (MTCH)

#### **MBMS Point-to-Multipoint Control Channel (MCCH):**

This logical channel is used for P-t-M downlink transmission of Control Plane information between network and the UEs in RRC Connected or Idle mode. The control plane information on MCCH is MBMS specific and is sent to UEs in a Cell with activated an MBMS Service. Short indications are always given to the UE to when to read the MCCH.

The MCCH is always mapped to one specific FACH in the S-CCPCH as indicated on the BCCH. The BCCH is broadcasting the MBMS System Information to UEs in order to provide them with information considering the MCCH like:

- MCCH schedule information (Access Info, Repetition Period, Modification Period).
- Configuration of the Radio Bearer carrying the MCCH (e.g. Scrambling Code)

So upon receiving the MBMS System Information the UE shall establish the Radio Bearer Carrying the MCCH channel in the Cell.

MCCH information is split into critical and non-critical information. The critical information is transmitted every “Repetition Period” and is made up of the:

- MBMS Service Information
- MBMS Radio Bearer Information



- MBMS Neighbouring Cell Information

The non-critical information corresponds to the MBMS Access Information.

#### **MBMS Service Information:**

The purpose of this signalling flow is for RNC to inform UEs of all the MBMS services available in the Cell. The MBMS Service Information shall be transmitted periodically to support mobility in the MBMS service.

For each MBMS Service listed in the MBMS Service Information contains at least the following information:

- MBMS Service ID,
- Indication if a P-t-M Bearer is established for the Service in the Cell.

The MBMS service IDs indicates the MBMS services which are being served in the cell or the MBMS services which can be served if the UE requests it. P-t-M indication indicates if the MBMS Service is transmitted on P-t-M or P-t-P channel type in the cell. If the MBMS Service is transmitted on a P-t-M channel type, it informs the UE of the need of reception of the MBMS Radio Bearer Information.

#### **MBMS Radio Bearer Information:**

The purpose of this signalling flow is for the RNC to inform UEs regarding the MTCH radio Bearer Information. The MBMS Radio Bearer Information is only available for P-t-M transmission. For each Service Listed in the MBMS Service Information and indicated that it's transmitted in a P-t-M channel type, contains at least the following information:

- MBMS Service ID
- MBMS UTRAN Cell Group Identifier (MBMS UCG-Id),
- Logical Channel Information
- Transport Channel Information
- Physical Channel Information

An MBMS UTRAN Cell Group Identifier is used to indicate to UEs which MBMS Cell Group the cell pertains to.

**MBMS Neighbouring Cell Information:**

The purpose of the MBMS Neighbouring Cell Information signalling flow is for the UTRAN to inform the UEs of the MTCH configuration in the Neighbouring Cells which are available for Selective Combining. Cells that are available for Selective Combining are only Cells that belongs to the same MBMS Cell Group. The MBMS Neighbouring Cell Information contains information describing the P-t-M Radio Bearer to which the MBMS Service it is mapped in the Neighbour Cell. For each MBMS Service (MBMS Service ID) that Selective Combining with one or more Neighbouring Cells is possible, the MBMS Neighbouring Cell Information includes for each Neighbouring Cell that Selective Combining is Possible:

- Cell ID,
- Transport channel information in the Cell,
- Physical channel information in the Cell,
- Radio Bearer information in the Cell,
- Selective combining information in the Cell.

With MBMS Neighbouring Cell Information the UE is able to receive MTCH transmission from neighbouring cell without reception of the MCCH of that cell.

**MBMS Access Information:**

The purpose of this signalling flow is for the RNC to inform UE(s) interested in a particular service of the potential need to establish an RRC connection. The MBMS ACCESS INFORMATION is transmitted during counting and re-counting on MCCH and it includes MBMS Service Id for each service for which counting is required and the associated access "probability factor".

### **MBMS Point-to-Multipoint Traffic Channel (MTCH)**

This logical channel is used for P-t-M downlink transmission of user plane information between network and the UEs in RRC Connected or Idle mode. The user plane information on MTCH is MBMS specific and is sent to UEs in a cell with activated MBMS Service.

The MTCH is always mapped to one specific FACH in the S-CCPCH as indicated on the MCCH.

## APPENDIX C: ENHANCED MBMS SIMULATOR FOR ADVANCED RRM<sub>s</sub>

The Radio Resource Management algorithms proposed in this Ph.D. dissertation have been implemented and evaluated by enhancing the MBMS simulator created during the B-BONE project [45]. This simulator was created using as a base the UMTS module provided by OPNET Modeller 11.0.A [46].

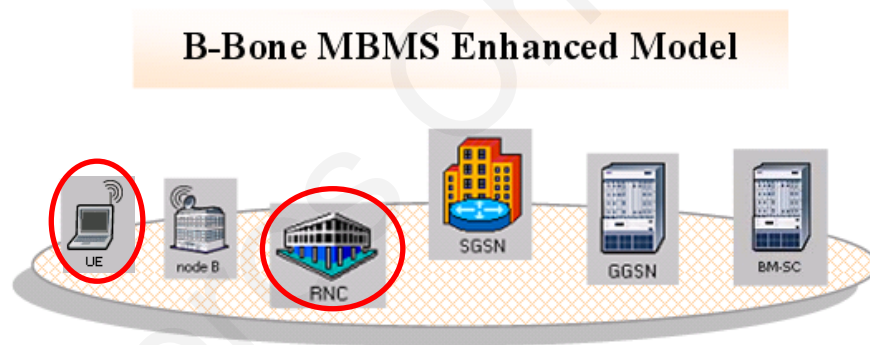

Our proposed solutions have been implemented by enhancing the RNC and the UE nodes of the B-BONE simulator with new properties, functionalities, data structures, statistics and packets. Our enhanced MBMS simulator along with some scenarios ready to be used or modified by the users based on their needs, will be found and downloaded at the NetRL website (<http://www.netrl.cs.ucy.ac.cy/>) following the “Simulators and Software” link provided there. The simulator implemented is very easy to use. Some instructions of how our enhanced MBMS simulator can be used for performing simulation related to our proposed MBMS handover control and MBMS service provision approaches are provided below.

### For the MBMS handover control approach

For performing simulations related to the “MBMS Handover control” approach the user can select, in the UE’s properties, between the **UMTS Handover Algorithm (Default)** and **MBMS Handover Algorithm (Optimized)**. Note that in case our proposed MBMS Handover algorithm is selected the “**Required Ec/No**” must be filled in by the user, indicating the minimum CPICH Ec/No value that should be measured by the UE from the P-t-M transmission mode cell for indicating a reliable reception of the FACH (i.e., this field indicates the FACH supported area coverage limit).

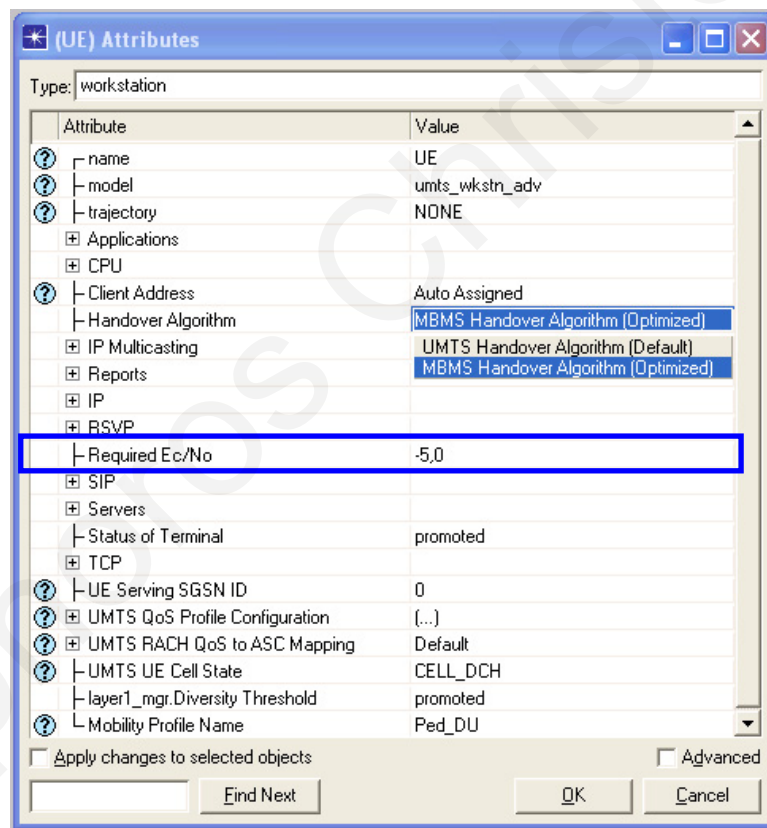

Moreover, the user must be sure that, in the RNC properties, in the “**Radio Resource Allocation Algorithm**” field, the **Current Radio Resource Allocation Algorithm** value is selected (Note that if the **Proposed Radio Resource Allocation Algorithm** value is selected here the functions related to the MBMS Handover algorithm will not be executed).

In addition, in the RNC properties, the user can define the “**Safety Time Threshold used (sec)**” value (this value will be used in the estimation of the Safety Margin parameter (see section 3.6.2.2)) and the “**Activation Time (sec)**” value (this value will be used for the estimation of the “Activation Hysteresis” parameter (see section 3.6.2.3)).

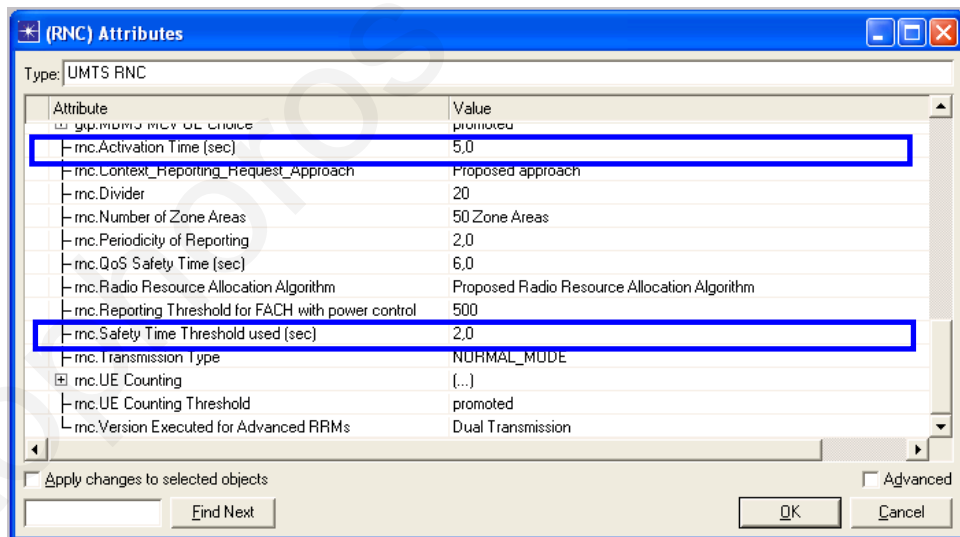
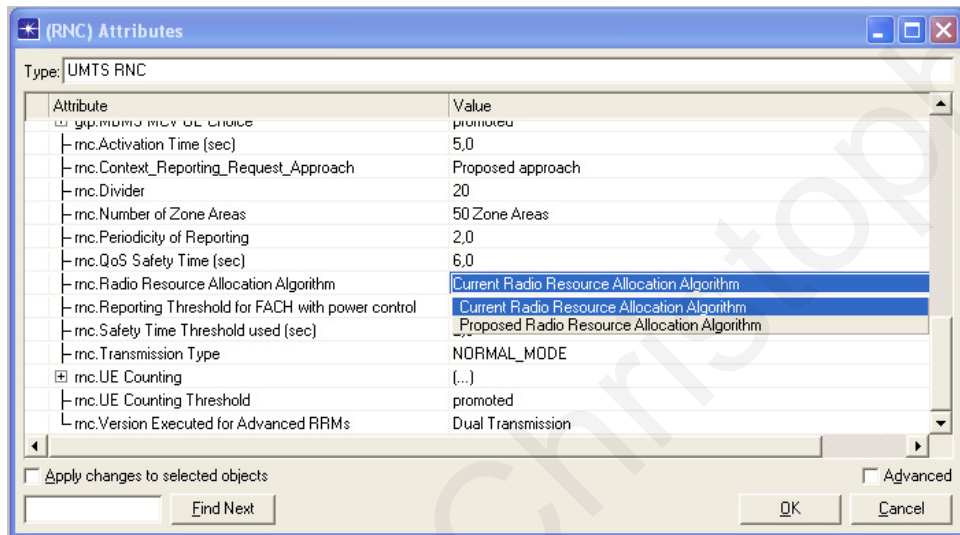

**For the Proposed MBMS service provision approach:**

Note: The current version of the simulator related to the Proposed MBMS service provision approach does not support inter- cell handovers.

For performing simulations related to the “Proposed MBMS service provision Approach” approach the user must first select, in the RNC’s properties, in the “**Radio Resource Allocation Algorithm**” field, the **Proposed Radio Resource Allocation Algorithm** value (note that if the **Current Radio Resource Allocation Algorithm** value is selected here the functions related to the Proposed MBMS service provision approach will not be executed).

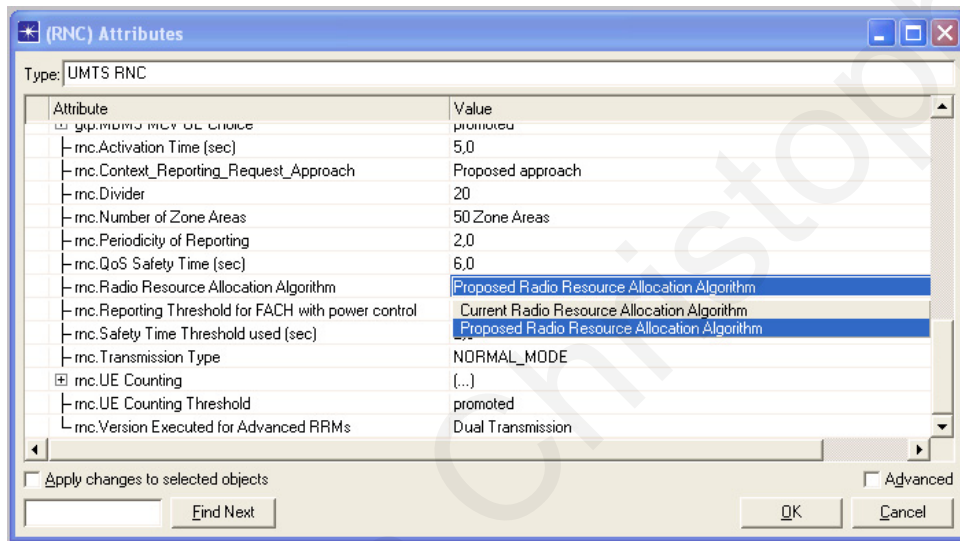

With the **Proposed Radio Resource Allocation Algorithm** value selected, the user can select one of the following five approaches (which we have also implemented for the comparative evaluation with our proposed “Dual Transmission mode cell” approach) to simulate:

- Dual Transmission (This is our proposed approach)
- Power Counting
- UE Counting
- Rate splitting
- FACH with Power Control

Also in the “**Periodicity of Reporting**” field, the user must also specify the time (in seconds) between consecutive reporting requests.

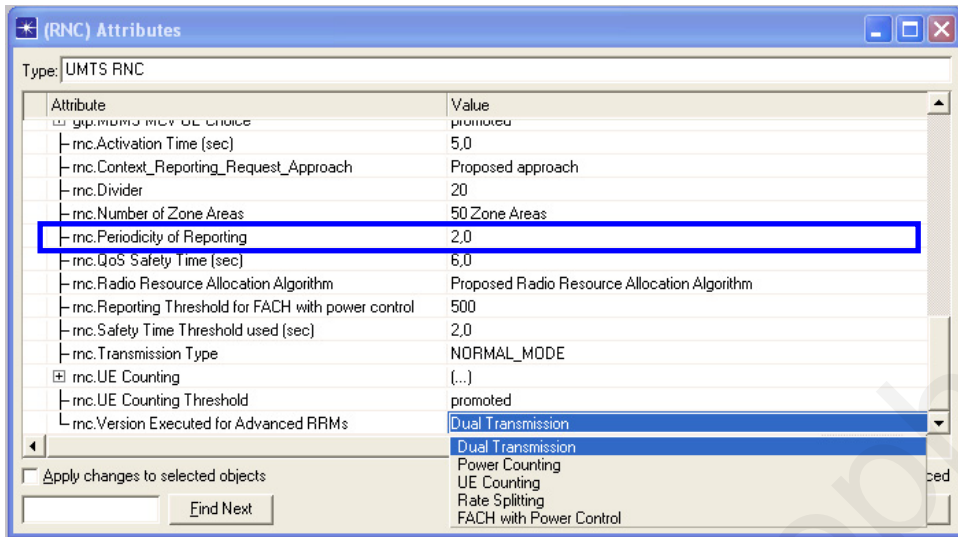

Moreover, in case our proposed “Dual Transmission mode cell” is selected, the user can select some other parameters that can be considered in the simulation. For example, the user can select the number of Zone Areas that the cell will be divided. In our simulator we allow the cell to be divided into:

- 5 Zone Areas
- 10 Zone Areas
- 20 Zone Areas
- 50 Zone Areas
- 100 Zone Areas
- 200 Zone Areas



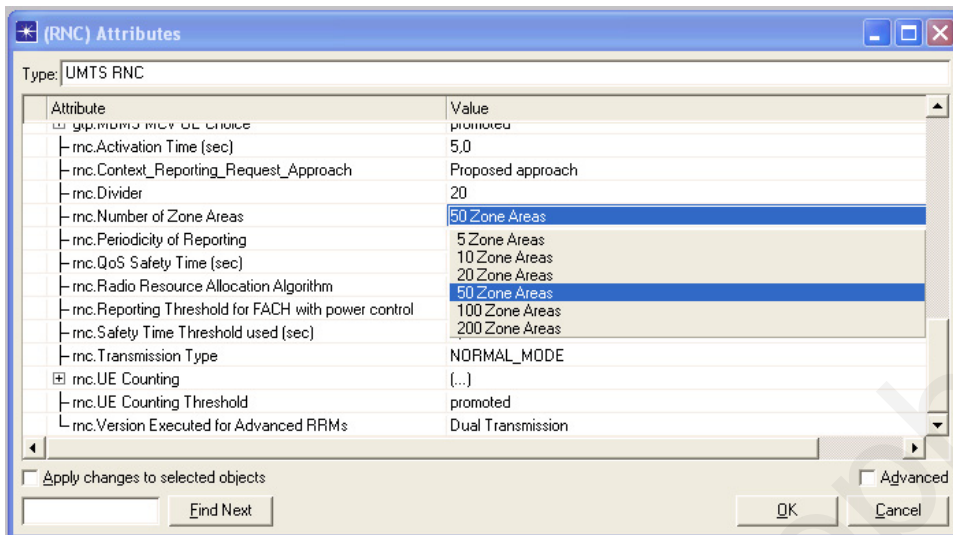

In addition, in case our proposed “Dual Transmission mode cell” is selected, the user can also select in the “**Context Reporting Request Approach**” either our **Proposed Approach** (as described in section 4.7.2) for performing the context request process or the **Current 3GPP proposed approach** (as described in [2]). The user can also define in the “**QoS Safety Time (sec)**” field the amount of time that our proposed “Dual Transmission mode cell” algorithm will considered for the transmission arrangement selection aiming to avoid any QoS degradation or intra-cell handovers.

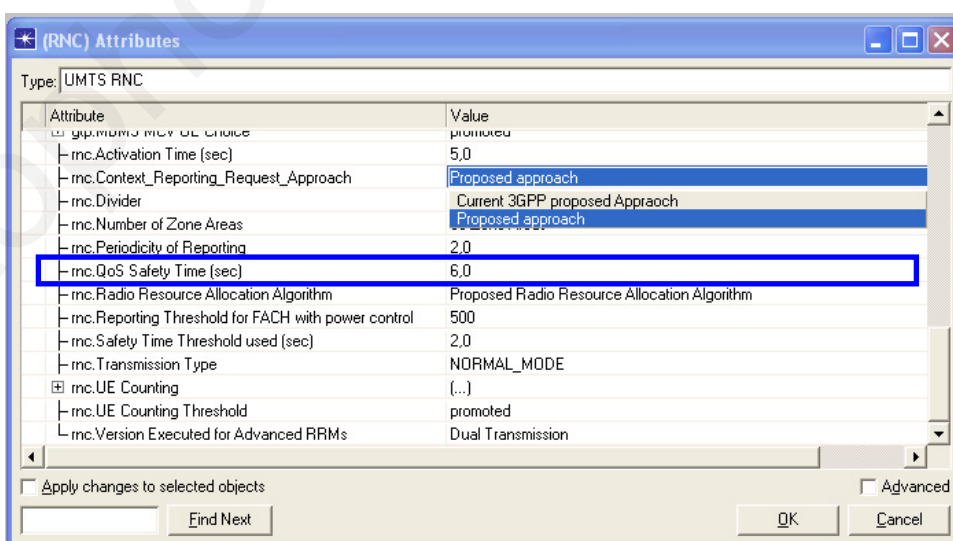

In case the “UE Counting” approach is selected, the user will have to indicate in the “UE Counting Threshold” field, the number of users that will justify the P-t-M transmission mode.

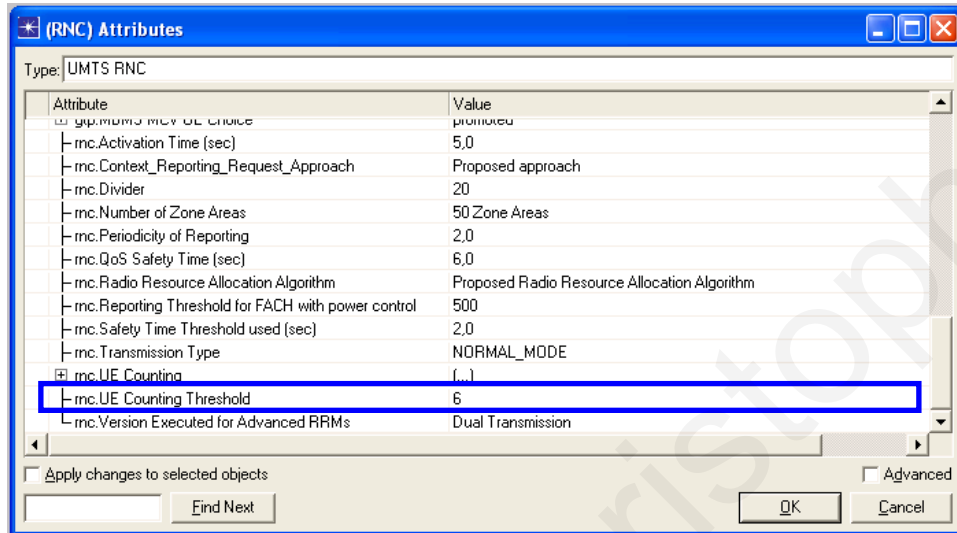

In case the “FACH with Power Control” approach is selected, the user will have to indicate in the “Reporting Threshold for FACH with power control” field, the threshold that the UEs will consider during the context reporting request process for providing a report. In this case this threshold defines the smaller distance (in meters) that the UE will have to be away from the Node-B in order to send a context report to the RNC.

